



Produttore di ghiaccio con contenitore incorporato - Sistema a palette
Produzione giornaliera fino a 31 kg

Hotel	██████████
Ristoranti	██████████
Fast food	██████████
Bar	██████████
Discoteche	██████████
Mercati ittici	██████████
Supermercati	██████████
Medicale & SPA	██████████
Industrie	██████████

► **Position n°**



► **Features & Plus**

- Cubetto cavo
- Carrozzeria AISI 304 Scotch Brite
- Classe Tropicale + 43° C
- Filtro Aria smontabile e pulibile
- Condensazione aria o acqua
- Superfici interne arrotondate per pulizia
- Isolamento contenitore HCFC-Free
- Bacinella acqua in ABS certificato FDA
- Sistema di sicurezza movimento bacinella
- RoHS Free
- Sportello isolato con apertura a scomparsa
- Funzionamento elettromeccanico
- Interruttore ON/OFF
- Carico automatico dell'acqua
- Voltaggio standard e voltaggi speciali
- HFC Free



Carrozzeria AISI 304 Scotch Brite



Filtro Aria smontabile e pulibile



Bacinella acqua in ABS certificato FDA



Sportello isolato con apertura a scomparsa

► **Cubetti disponibili per questo modello**

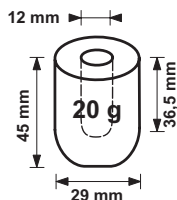

► **Prod. 24h**

T. aria	T. acqua		kg	lbs	
	10° C	50° F			7° C
21° C	70° F	15° C	60° F	22	49

Garanzia 2 Anni
soggetta a limitazioni

► **Certificazioni disponibili per questo modello**





Ice Finger

IMF 26 HC



Produttore di ghiaccio con contenitore incorporato - Sistema a palette
Produzione giornaliera fino a 31 kg

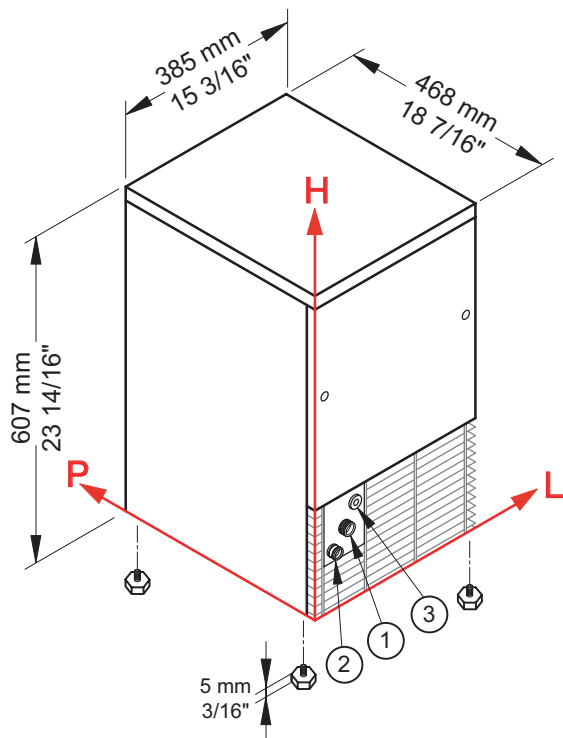

► Condizioni d'installazione

- Installazione: **Interna**

	Min	Max
Temperatura ambiente	+10° C / +50° F	+43° C / 110° F
Temperatura acqua	+3° C / +37° F	+32° C / +90° F
Voltaggio	-10%	+10%
Pres. acqua in ingresso	1bar (14 psi)	6bar (84 psi)

► Performance

	Temperatura acqua	Temperatura acqua					
		7° C	45° F	15° C	60° F	21° C	70° F
Temperatura aria	10° C	31 kg					
	50° F	68 lbs					
	21° C		22 kg				
	70° F			49 lbs			
	32° C				16 kg		
	90° F					35 lbs	

► Connessioni

Le misure sono riferite all'angolo del retro in basso a sinistra (L-H-Ø)

- ① Ingresso acqua: 111 mm / 4 6/16" - 175 mm / 6 14/16" - 3/4" ② Scarico acqua: 49 mm / 1 15/16" - 130 mm / 5 2/16" - 24 mm / 15/16"
③ Connessione elettrica: 156 mm / 6 2/16" - 211 mm / 8 5/16"

► Dati tecnici

Produzione in 24h	22 kg / 49 lbs	Consumo d'acqua	A: 3 l/kg - 36 gal/100 lbs
Capacità contenitore, fino a	4 kg / 9 lbs		W: 17 l/kg - 204 gal/100 lbs
Condensazione	A - W	Dimensioni (L-P-H mm)	385 - 468 - 607
Tipo di cubetto	A-20g	(L-P-H in)	15 3/16 - 18 7/16 - 23 14/16
Refrigerante	R290	Dimensioni imballo (L-P-H mm)	440 - 520 - 800
Voltaggio standard	220-240 V ~ 50 Hz	(L-P-H in)	17 5/16 - 20 8/16 - 31 8/16
Ptenza media assorbita	300 W	Peso netto	36 kg / 79 lbs
Fusibile	10 A	Peso lordo	42 kg / 93 lbs
Consumo Elettrico	31 kWh/100kg	Finitura	Acciaio inox 18/8, scotch brite

Tutti i dati tecnici sono da considerarsi validi alle seguenti condizioni:

Dimensioni esclusi i piedini
Cubetto standard (20 g)
Temperatura ambiente +21° C
Temperatura acqua +15° C
Consumo elettrico a +32° C (Voltaggio standard)
Potenza media assorbita a +43° C (Voltaggio standard)

I modelli ed i dati riportati possono essere soggetti a modifiche senza alcun preavviso

Rev. 00 - Pubblicato Marzo 2021



www.bremaice.it
info@bremaicegroup.it

We are Brema

