

SilvioMondinoStudio

T-Double
Installation Guide - Rev. 01/20

COMPONENTS

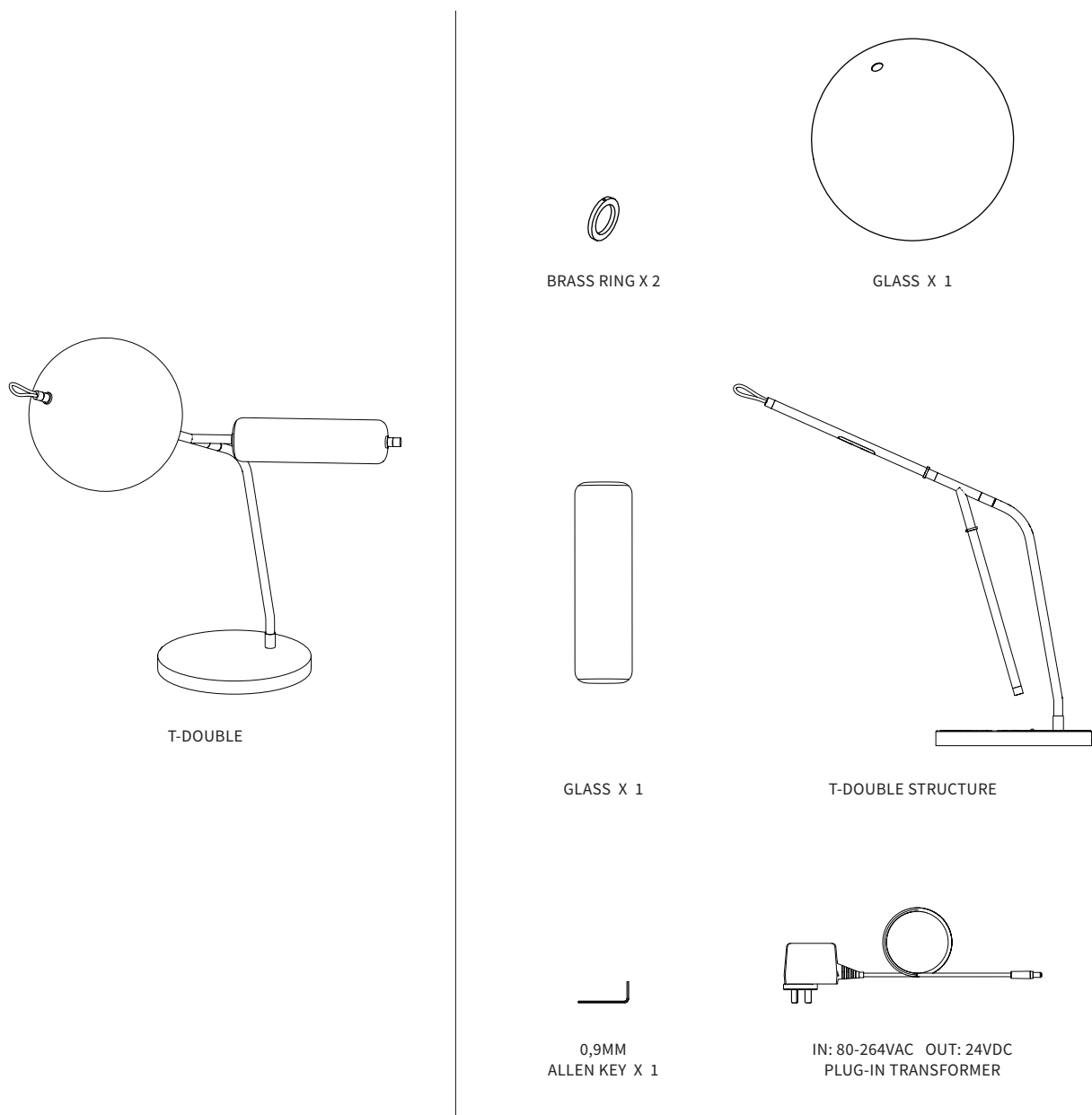

SAFETY INFORMATION

ONLY SUITABLE FOR DIRECT MOUNTING ON NON-COMBUSTIBLE SURFACES.
SUITABLE FOR DRY, INDOOR USE ONLY.
MAXIMUM AMBIENT TEMPERATURE: 30°C

LAMP ASSEMBLY

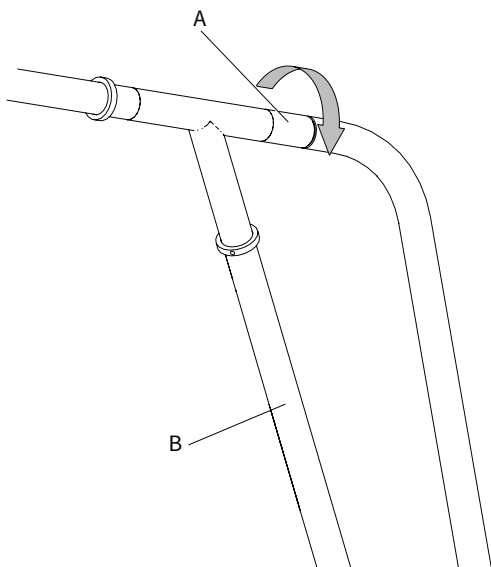

1 - ROTATE THE ARM STOPPER (A) TO UNLOCK THE ARM (B).

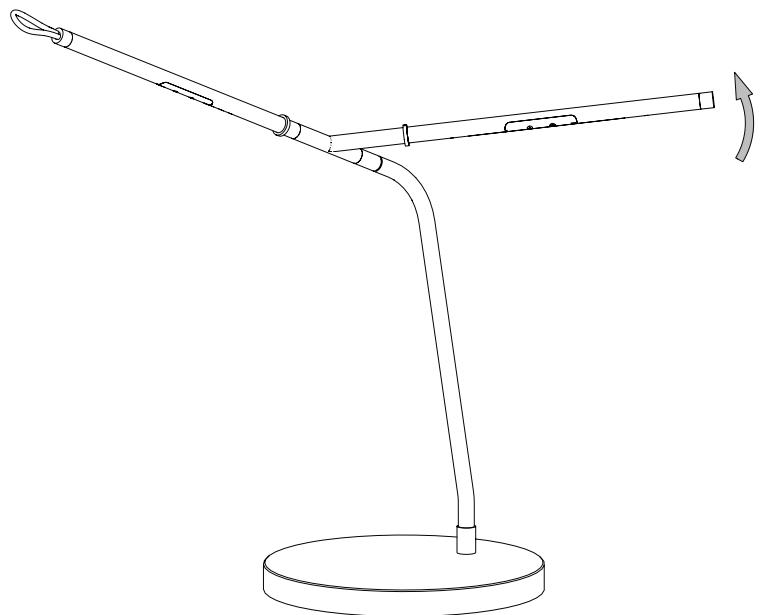

2 - TURN THE ARM IN THE DESIRED POSITION.

NOTE

PLEASE CONTACT A LICENSED ELECTRICIAN.

USE NITRILE GLOVES TO HANDLE THE COMPONENTS TO AVOID FINGERPRINTS.

ALL BRASS FINISHES ARE UNLACQUERED AND HAND SEALED WITH A LIGHT LAYER OF WAX.

THE FINISH IS LIVE AND IS INTENDED TO PATINA OVER TIME.

WE TRY OUR BEST FOR ALL GOODS TO LEAVE OUR PREMISES IN PRISTINE CONDITION, BUT SOMETIMES PRODUCTS MAY

ARRIVE WITH MINOR OXIDISATION MARKS, REVEALING THE HIGH CRAFTSMANSHIP PROCESS.

LAMP ASSEMBLY

GLASS ASSEMBLY

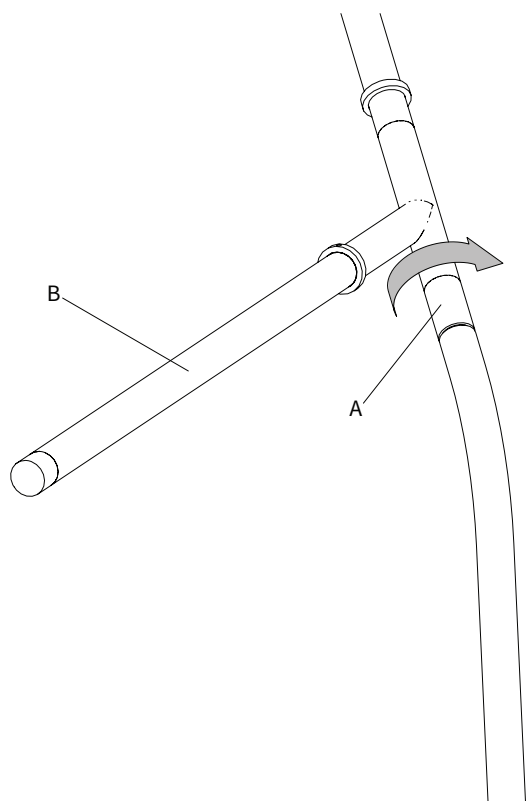

3 - KEEP THE ARM (B) WITH HAND AND ROTATE THE ARM STOPPER (A) TO LOCK THE ARM IN POSITION.

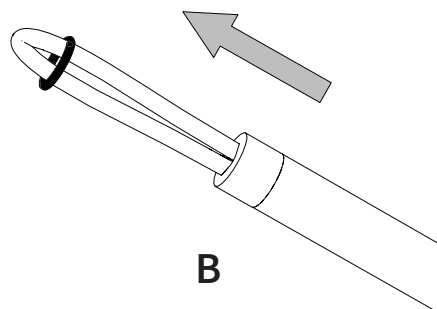
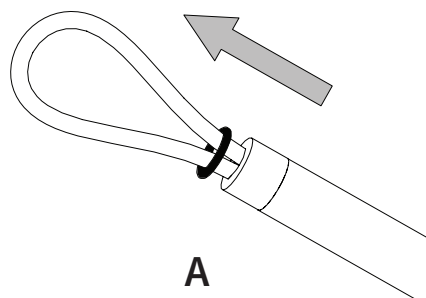

4 - PULL THE RUBBER RING (A), IN ORDER TO RESHAPE THE LEATHER SENSOR AS IN FIGURE (B).

NOTE

PLEASE CONTACT A LICENSED ELECTRICIAN.

USE NITRILE GLOVES TO HANDLE THE COMPONENTS TO AVOID FINGERPRINTS.

ALL BRASS FINISHES ARE UNLACQUERED AND HAND SEALED WITH A LIGHT LAYER OF WAX.

THE FINISH IS LIVE AND IS INTENDED TO PATINA OVER TIME.

WE TRY OUR BEST FOR ALL GOODS TO LEAVE OUR PREMISES IN PRISTINE CONDITION, BUT SOMETIMES PRODUCTS MAY ARRIVE WITH MINOR OXIDISATION MARKS, REVEALING THE HIGH CRAFTSMANSHIP PROCESS.

GLASS ASSEMBLY

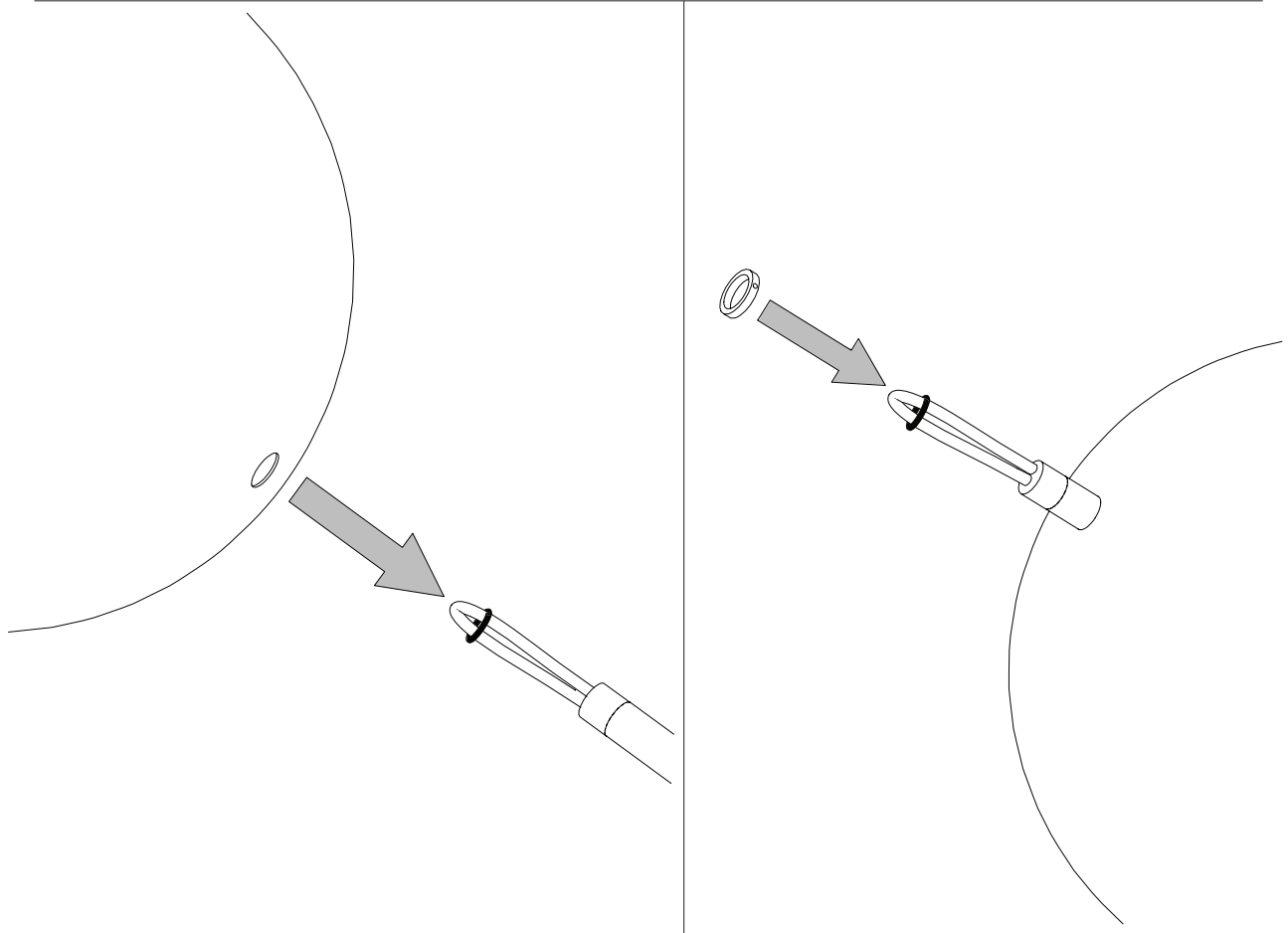

5 - FIT THE GLASS ONTO THE ROD.

6 - PLACE THE RING ON THE ROD.

NOTE

PLEASE CONTACT A LICENSED ELECTRICIAN.

USE NITRILE GLOVES TO HANDLE THE COMPONENTS TO AVOID FINGERPRINTS.

ALL BRASS FINISHES ARE UNLACQUERED AND HAND SEALED WITH A LIGHT LAYER OF WAX.

THE FINISH IS LIVE AND IS INTENDED TO PATINA OVER TIME.

WE TRY OUR BEST FOR ALL GOODS TO LEAVE OUR PREMISES IN PRISTINE CONDITION, BUT SOMETIMES PRODUCTS MAY ARRIVE WITH MINOR OXIDISATION MARKS, REVEALING THE HIGH CRAFTSMANSHIP PROCESS.

GLASS ASSEMBLY

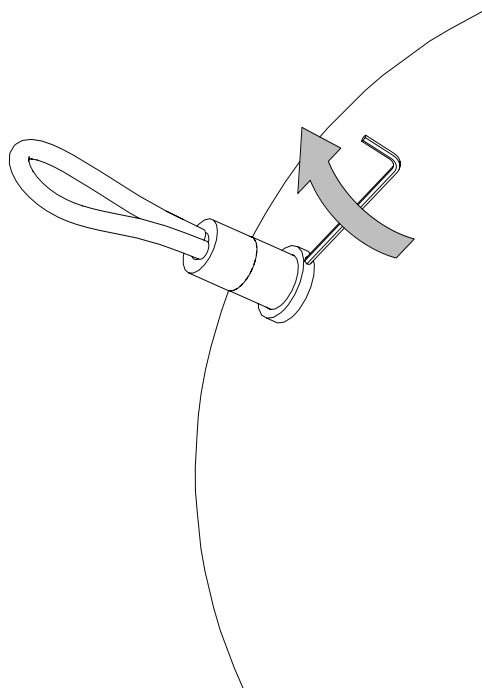

7 - PRESS THE BRASS RING AGAINST THE GLASS AND GENTLY BLOCK THE RING IN PLACE WITH SET SCREW.

USE THE PROVIDED 0,9MM ALLEN-KEY.

8 - PULL OUT THE RUBBER RING AND RESHAPE THE LEATHER SENSOR.

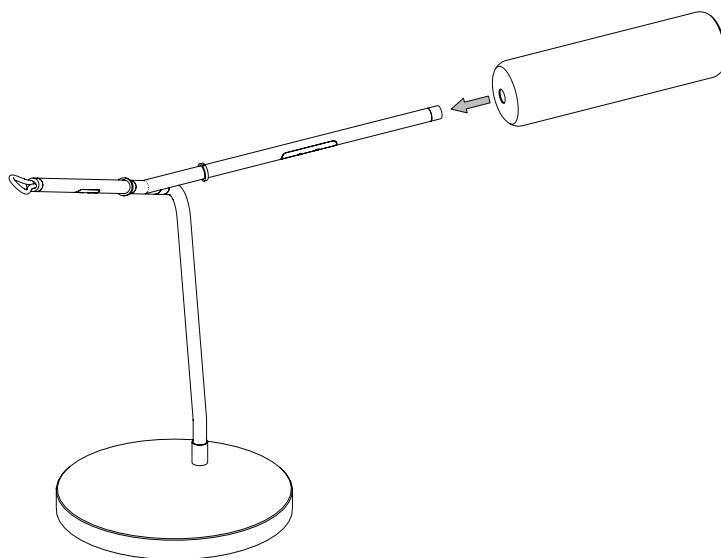

9 - FIT THE GLASS AND THE RING ON THE STEM.

NOTE

PLEASE CONTACT A LICENSED ELECTRICIAN.

USE NITRILE GLOVES TO HANDLE THE COMPONENTS TO AVOID FINGERPRINTS.

ALL BRASS FINISHES ARE UNLACQUERED AND HAND SEALED WITH A LIGHT LAYER OF WAX.

THE FINISH IS LIVE AND IS INTENDED TO PATINA OVER TIME.

WE TRY OUR BEST FOR ALL GOODS TO LEAVE OUR PREMISES IN PRISTINE CONDITION, BUT SOMETIMES PRODUCTS MAY ARRIVE WITH MINOR OXIDISATION MARKS, REVEALING THE HIGH CRAFTSMANSHIP PROCESS.

GLASS ASSEMBLY

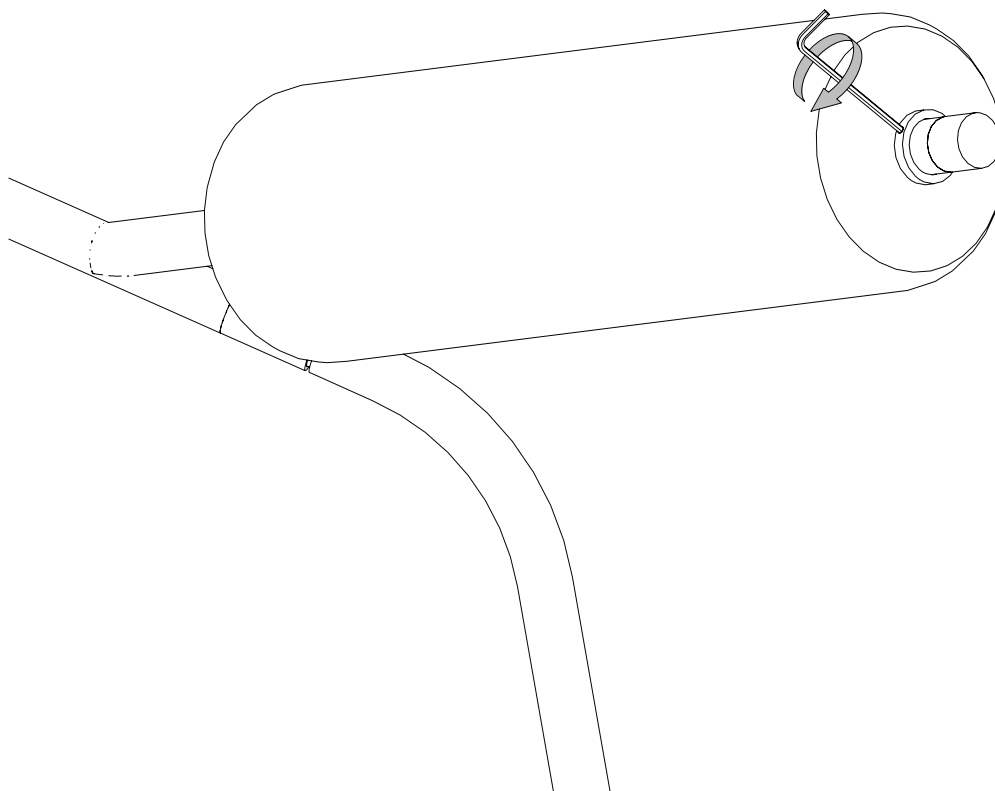

10 - PRESS THE BRASS RING AGAINST THE GLASS AND GENTLY
BLOCK THE RING IN PLACE WITH SET SCREW.

USE THE PROVIDED 0,9MM ALLEN-KEY.

NOTE

PLEASE CONTACT A LICENSED ELECTRICIAN.

USE NITRILE GLOVES TO HANDLE THE COMPONENTS TO AVOID FINGERPRINTS.

ALL BRASS FINISHES ARE UNLACQUERED AND HAND SEALED WITH A LIGHT LAYER OF WAX.

THE FINISH IS LIVE AND IS INTENDED TO PATINA OVER TIME.

WE TRY OUR BEST FOR ALL GOODS TO LEAVE OUR PREMISES IN PRISTINE CONDITION, BUT SOMETIMES PRODUCTS MAY
ARRIVE WITH MINOR OXIDISATION MARKS, REVEALING THE HIGH CRAFTSMANSHIP PROCESS.