

SilvioMondinoStudio

Nuvole Pendant Light
Installation Guide - Rev. 01/23

COMPONENTS

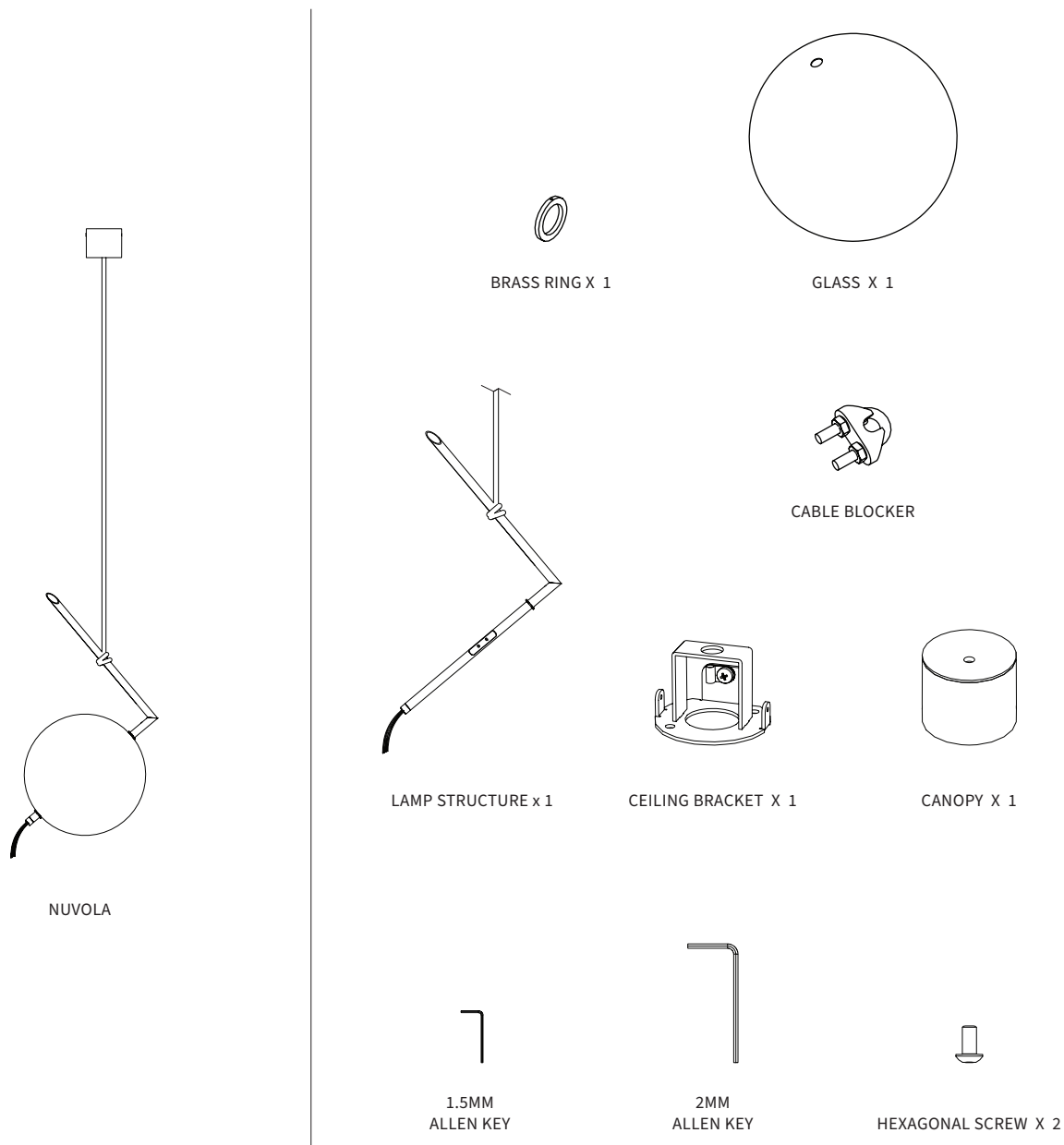

SAFETY INFORMATION

ONLY SUITABLE FOR DIRECT MOUNTING ON NON-COMBUSTIBLE SURFACES.
SUITABLE FOR DRY, INDOOR USE ONLY.
MAXIMUM AMBIENT TEMPERATURE: 30°C

LAMP BRACKET ASSEMBLY

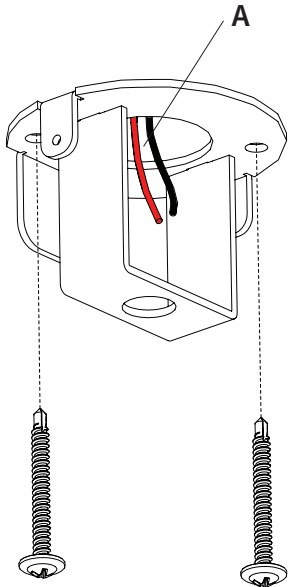
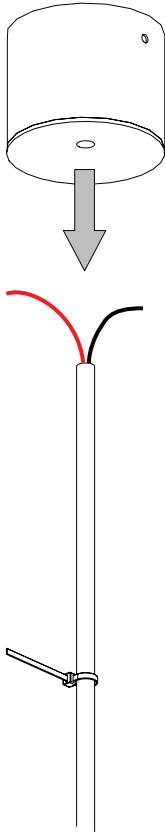
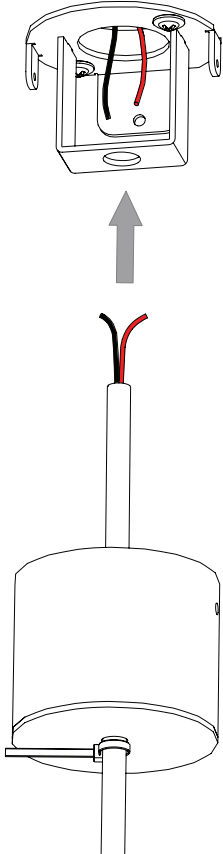
		
<p>1 - SECURE THE DRIVER PLATE TO THE CEILING USING ANCHORS SCREWS.</p> <p>MAKE SURE 24VCC ELECTRICAL WIRES (A) ARE PULLED OUT FROM THE WALL AS PICTURED</p>	<p>3 - FIX A CABLE TIE AROUND THE LEATHER CABLE AND THEN SLIDE THE CANOPY ONTO THE CABLE.</p>	<p>4 - SLIDE THE LEATHER CABLE INTO THE BRACKET HOLE.</p>

NOTE

PLEASE CONTACT A LICENSED ELECTRICIAN.
 USE NITRILE GLOVES TO HANDLE THE COMPONENTS TO AVOID FINGERPRINTS.
 ALL BRUSHED BRASS SURFACES ARE SEALED TO SLOW DOWN THE PATINA DURING THE TIME.
 POLISHED BRASS SURFACES ARE "LIVE" AND CAN BE RE-POLISHED USING A POLISHING CREAM.
 UNEVEN SURFACES ON OXIDIZED FINISHING ARE A CHARACTERISTIC OF UNICITY, REVEALING THE CRAFTSMANSHIP PROCESS.

LAMP BRACKET ASSEMBLY

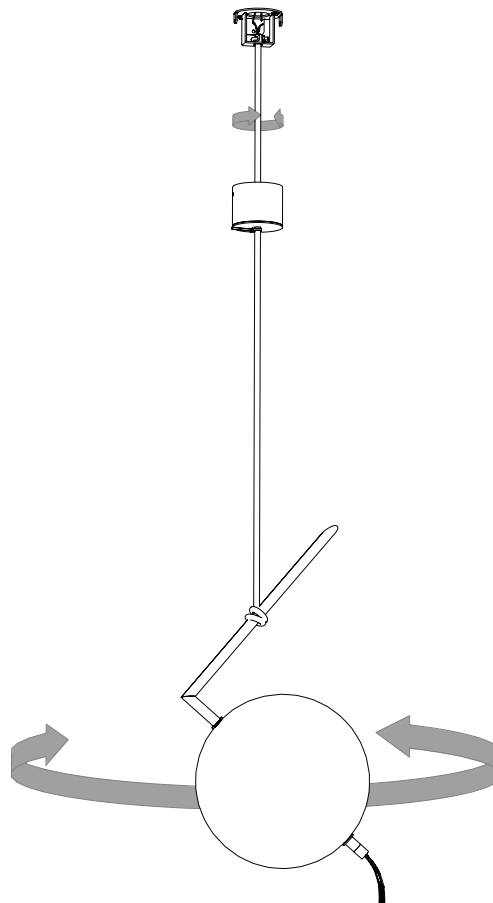
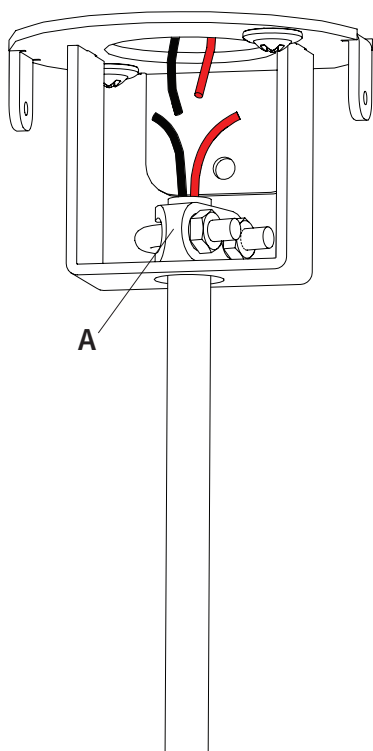

5 - LOCK THE PENDANT CABLE IN POSITION WITH THE CABLE BLOCKER (A) PROVIDED.

6- TURN ROPE UNTIL THE PENDANT IS IN THE DESIRED POSITION.

NOTE

PLEASE CONTACT A LICENSED ELECTRICIAN.
USE NITRILE GLOVES TO HANDLE THE COMPONENTS TO AVOID FINGERPRINTS.
ALL BRUSHED BRASS SURFACES ARE SEALED TO SLOW DOWN THE PATINA DURING THE TIME.
POLISHED BRASS SURFACES ARE "LIVE" AND CAN BE RE-POLISHED USING A POLISHING CREAM.
UNEVEN SURFACES ON OXIDIZED FINISHING ARE A CHARACTERISTIC OF UNICITY, REVEALING THE CRAFTSMANSHIP PROCESS.

LAMP BRACKET ASSEMBLY

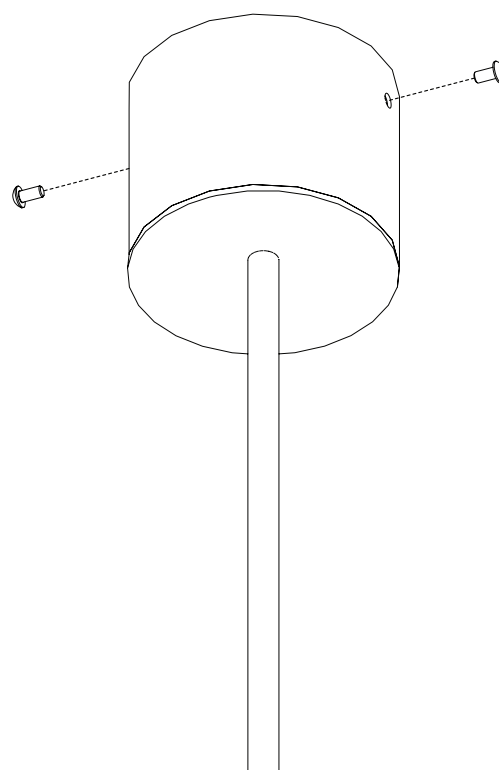
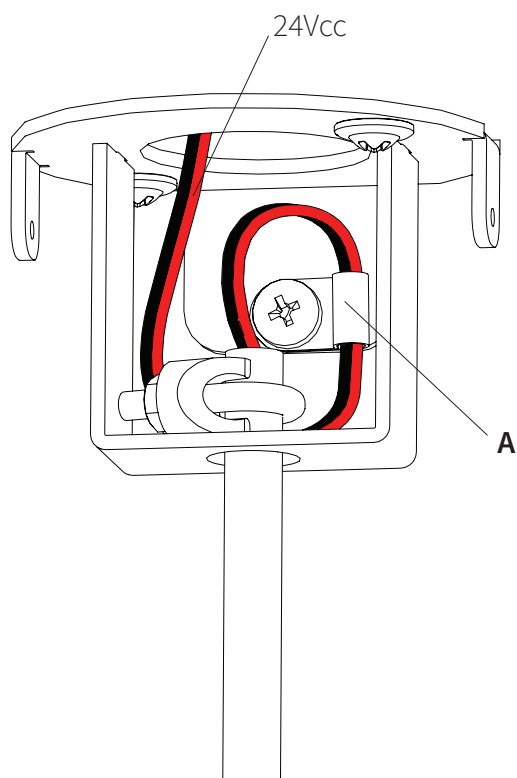

7 - MAKE ELECTRICAL CONNECTIONS PAYING ATTENTION TO THE POLARITY. (RED +24VCC)

8 - LOCK ELECTRICAL WIRES WITH THE SECURITY CABLE CLAMP AS PICTURED (A).

9 - RISE THE CANOPY AND LOCK IN POSITION WITH THE HEXAGONAL SCREW PROVIDED USING THE 3MM ALLEN KEY.

NOTE

PLEASE CONTACT A LICENSED ELECTRICIAN.
 USE NITRILE GLOVES TO HANDLE THE COMPONENTS TO AVOID FINGERPRINTS.
 ALL BRUSHED BRASS SURFACES ARE SEALED TO SLOW DOWN THE PATINA DURING THE TIME.
 POLISHED BRASS SURFACES ARE "LIVE" AND CAN BE RE-POLISHED USING A POLISHING CREAM.
 UNEVEN SURFACES ON OXIDIZED FINISHING ARE A CHARACTERISTIC OF UNICITY, REVEALING THE CRAFTSMANSHIP PROCESS.

GLASS ASSEMBLY

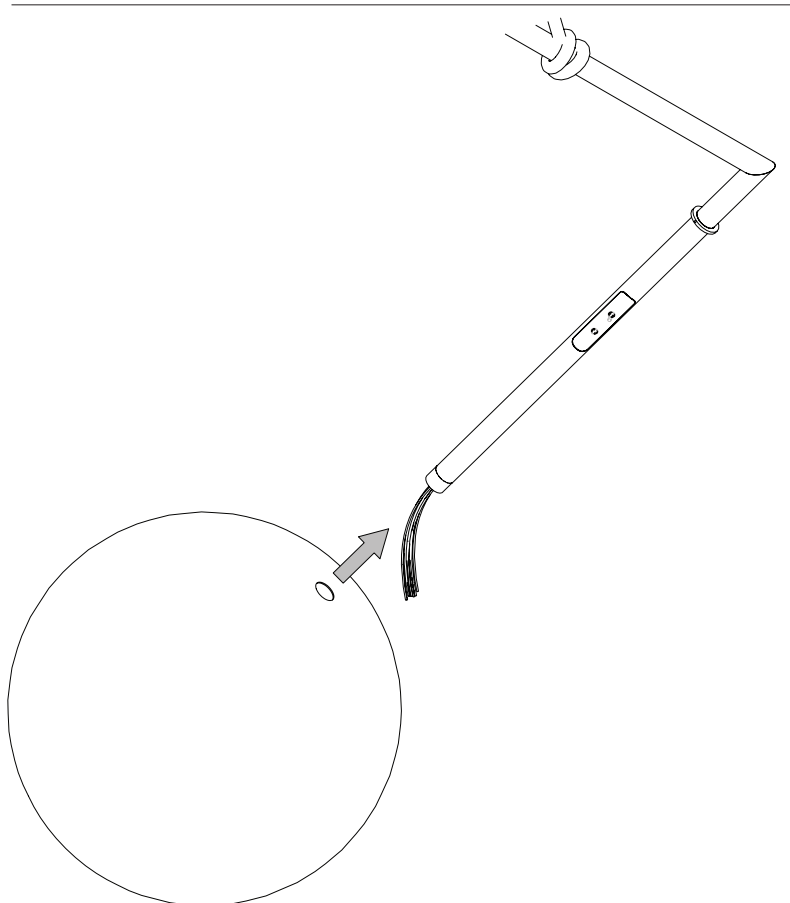

10 - SLIDE THE GLASS ON THE BRASS ROD.

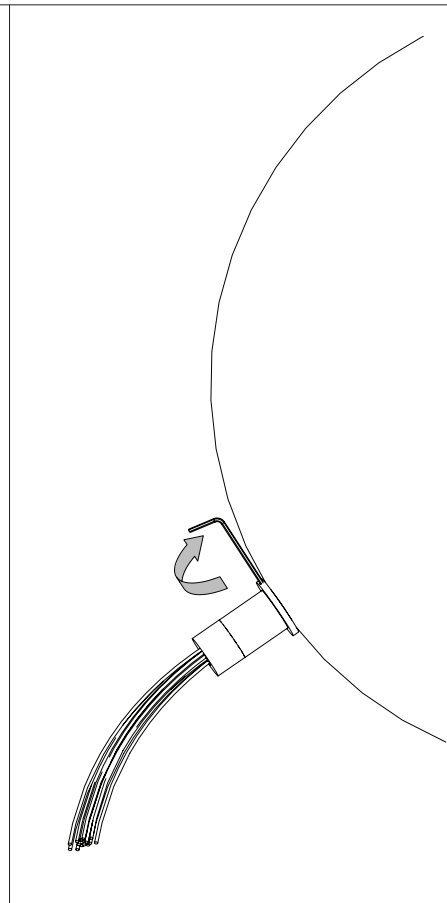

11 - SLIDE THE RING ON THE BRASS ROD.

12 - GENTLY SECURE IN PLACE WITH SET SCREWS ON TOP USING THE PROVIDED 1.5MM ALLEN-KEY

NOTE

PLEASE CONTACT A LICENSED ELECTRICIAN.
USE NITRILE GLOVES TO HANDLE THE COMPONENTS TO AVOID FINGERPRINTS.
ALL BRUSHED BRASS SURFACES ARE SEALED TO SLOW DOWN THE PATINA DURING THE TIME.
POLISHED BRASS SURFACES ARE "LIVE" AND CAN BE RE-POLISHED USING A POLISHING CREAM.
UNEVEN SURFACES ON OXIDIZED FINISHING ARE A CHARACTERISTIC OF UNICITY, REVEALING THE CRAFTSMANSHIP PROCESS.