

SilvioMondinoStudio

Lune Three Lights (US)
Installation Guide - Rev. 01/21

COMPONENTS

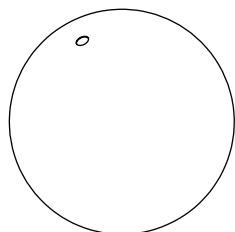
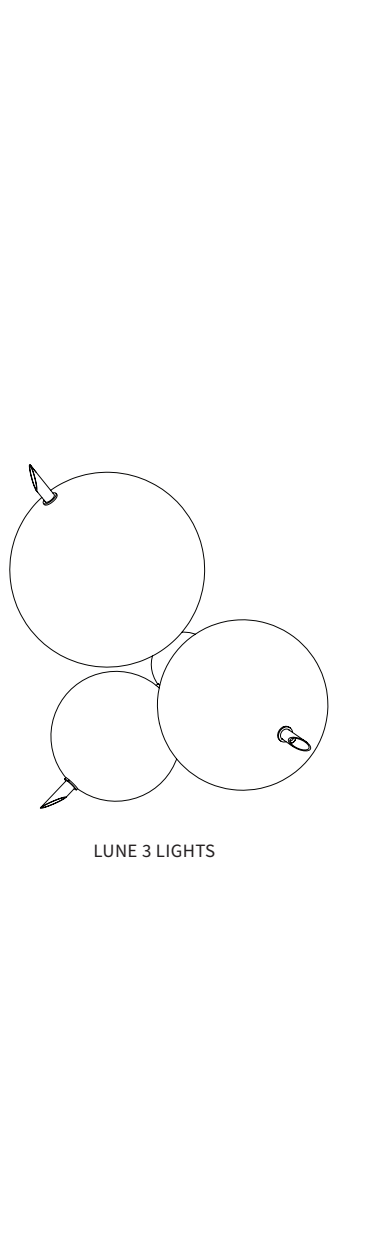

GLASS X 1

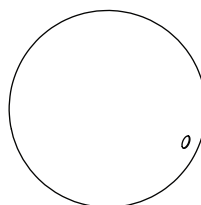

GLASS X 1

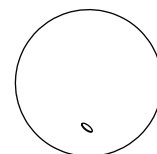

GLASS X 1

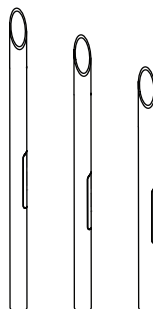

LED MODULE x 3

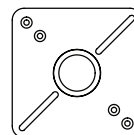

4" J-BOX BRACKET X 1

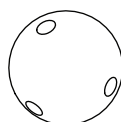

LAMP STRUCTURE x 1

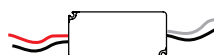

24VDC 1000mA
 TRANSFORMER X 1



BRASS RING X 3



WIRE NUTS X 2



1,5MM
 ALLEN KEY X 1



3MM
 ALLEN KEY X 1

SAFETY INFORMATION

ONLY SUITABLE FOR DIRECT MOUNTING ON NON-COMBUSTIBLE SURFACES.
 SUITABLE FOR DRY, INDOOR USE ONLY.
 MAXIMUM AMBIENT TEMPERATURE: 30°C
 THE CLIENT IS RESPONSIBLE TO ENSURE THAT THE WALL/CEILING HAS ADEQUATE STRUCTURAL SUPPORT FOR THE LAMP.

J-BOX - BRACKET ASSEMBLY

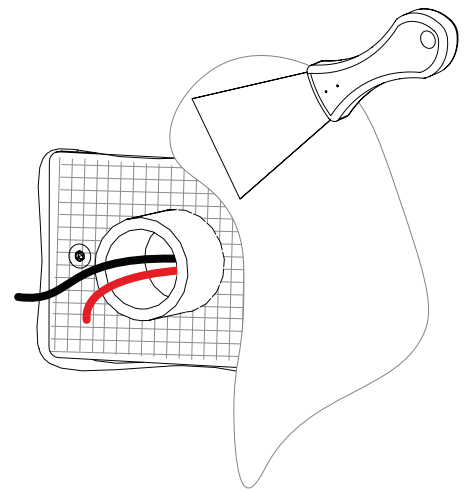
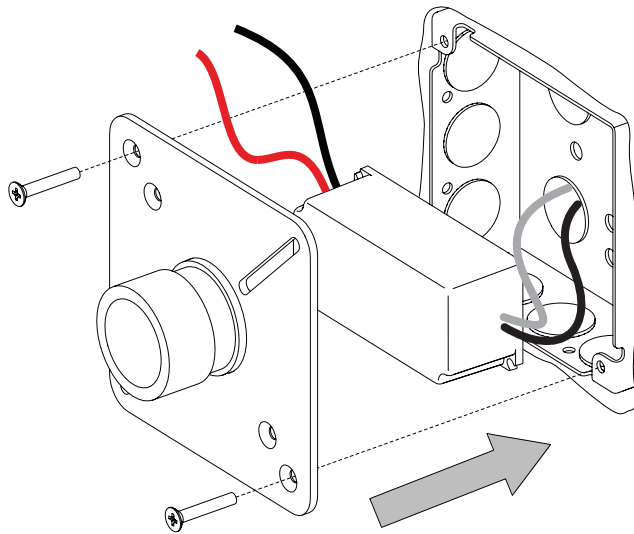

1 - CONNECT THE N-L INPUT OF THE TRANSFORMER TO THE ELECTRICAL SYSTEM AND PLACE IT INTO THE 4" SQUARE JUNCTION BOX.

WRONG CONNECTION WILL DAMAGE IRREPARABLY THE TRANSFORMER.

2 - SECURE THE BRACKET TO THE 4" J-BOX USING APPROPRIATE SCREWS.

ENSURE THE WALL/CEILING HAS ADEQUATE STRUCTURAL SUPPORT FOR THE BRACKET AND THE LAMP WEIGHT.

3 - PLASTER THE WALL AND COVER THE BRACKET. (PLACE ADHESIVE GAUZE STRIPS ON THE BRACKET BEFORE FILL WITH PLASTER)

MAKE SURE 24VCC TRANSFORMER WIRES ARE PULLED OUT FROM THE CENTRAL HOLE.

NOTE

PLEASE CONTACT A LICENSED ELECTRICIAN.

USE NITRILE GLOVES TO HANDLE THE COMPONENTS TO AVOID FINGERPRINTS.

ALL BRASS FINISHES ARE UNLACQUERED AND HAND SEALED WITH A LIGHT LAYER OF WAX.

THE FINISH IS LIVE AND IS INTENDED TO PATINA OVER TIME.

WE TRY OUR BEST FOR ALL GOODS TO LEAVE OUR PREMISES IN PRISTINE CONDITION, BUT SOMETIMES PRODUCTS MAY ARRIVE WITH MINOR OXIDISATION MARKS, REVEALING THE HIGH CRAFTSMANSHIP PROCESS.

LAMP ASSEMBLY

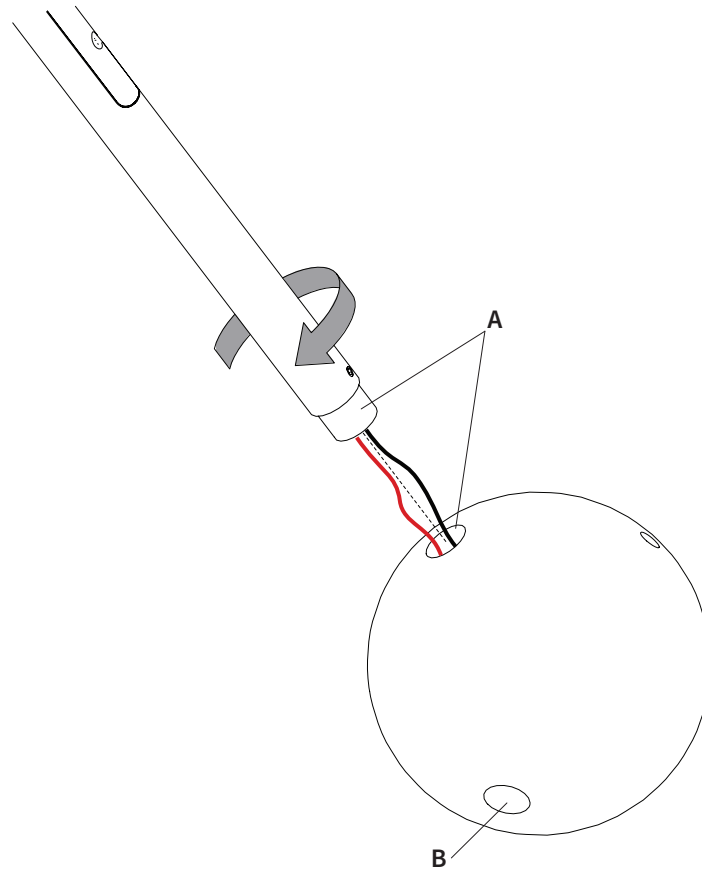

4 - GENTLY SCREW EACH ROD ONTO THE CORRESPONDENT HOLE ONTO THE SPHERE.

PLEASE REFER TO THE LABELS TO CORRECTLY PAIR RODS AND HOLES.

NOTE

PLEASE CONTACT A LICENSED ELECTRICIAN.

USE NITRILE GLOVES TO HANDLE THE COMPONENTS TO AVOID FINGERPRINTS.

ALL BRASS FINISHES ARE UNLACQUERED AND HAND SEALED WITH A LIGHT LAYER OF WAX.

THE FINISH IS LIVE AND IS INTENDED TO PATINA OVER TIME.

WE TRY OUR BEST FOR ALL GOODS TO LEAVE OUR PREMISES IN PRISTINE CONDITION, BUT SOMETIMES PRODUCTS MAY ARRIVE WITH MINOR OXIDISATION MARKS, REVEALING THE HIGH CRAFTSMANSHIP PROCESS.

LAMP PLACEMENT

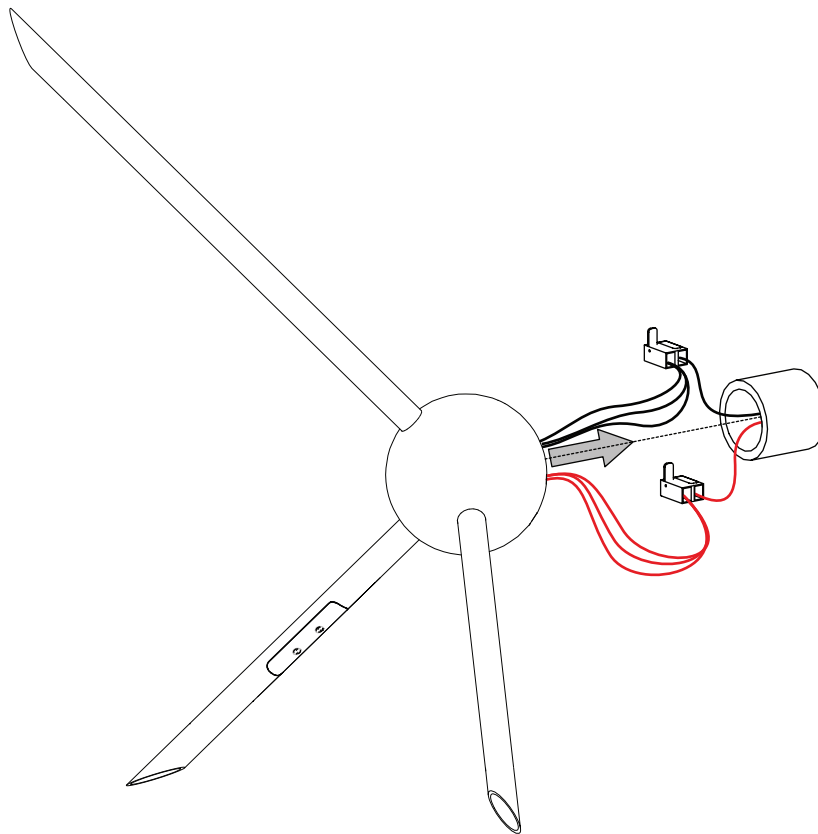

5 - MAKE ELECTRICAL CONNECTIONS PAYING ATTENTION TO THE POLARITY. (RED +24Vcc)
JOIN THE THREE RED WIRES AND CONNECT AT THE WIRE NUT. DO THE SAME WITH THE BLACKS.

WRONG CONNECTION WILL DAMAGE IRREPARABLY THE LED MODULE.

5 - PUSH THE WIRES BACK THROUGH THE CENTRAL HOLE AND FIT THE LAMP ON THE BRACKET WHILE CAREFULLY HOLDING FIXTURE

NOTE

PLEASE CONTACT A LICENSED ELECTRICIAN.

USE NITRILE GLOVES TO HANDLE THE COMPONENTS TO AVOID FINGERPRINTS.

ALL BRASS FINISHES ARE UNLACQUERED AND HAND SEALED WITH A LIGHT LAYER OF WAX.

THE FINISH IS LIVE AND IS INTENDED TO PATINA OVER TIME.

WE TRY OUR BEST FOR ALL GOODS TO LEAVE OUR PREMISES IN PRISTINE CONDITION, BUT SOMETIMES PRODUCTS MAY ARRIVE WITH MINOR OXIDISATION MARKS, REVEALING THE HIGH CRAFTSMANSHIP PROCESS.

LAMP PLACEMENT

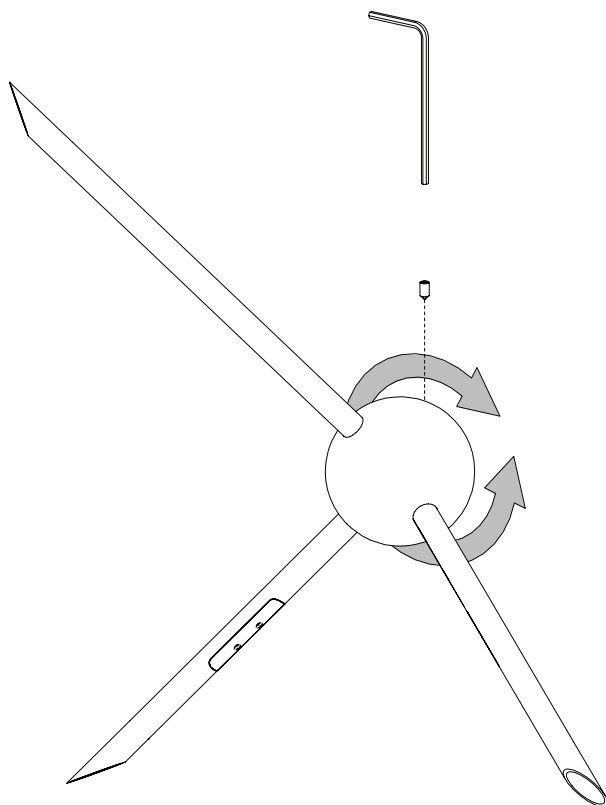

7 - ROTATE THE LAMP BODY IN THE RIGHT POSITION.

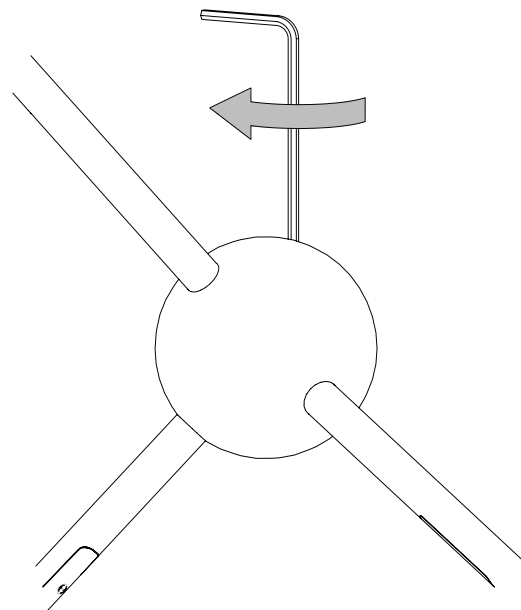

8 - SECURE IN PLACE WITH SET SCREWS ON TOP USING THE PROVIDED 3MM ALLEN-KEY

NOTE

PLEASE CONTACT A LICENSED ELECTRICIAN.
USE NITRILE GLOVES TO HANDLE THE COMPONENTS TO AVOID FINGERPRINTS.
ALL BRASS FINISHES ARE UNLACQUERED AND HAND SEALED WITH A LIGHT LAYER OF WAX.
THE FINISH IS LIVE AND IS INTENDED TO PATINA OVER TIME.
WE TRY OUR BEST FOR ALL GOODS TO LEAVE OUR PREMISES IN PRISTINE CONDITION, BUT SOMETIMES PRODUCTS MAY ARRIVE WITH MINOR OXIDISATION MARKS, REVEALING THE HIGH CRAFTSMANSHIP PROCESS.

GLASS ASSEMBLY

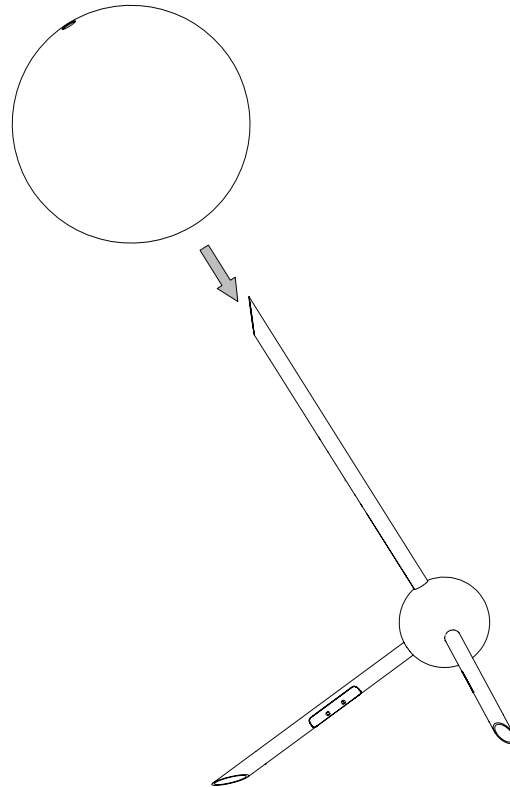

9 - FIT THE GLASS ONTO THE ROD, STARTING FROM THE BIG ONE.

NOTE

PLEASE CONTACT A LICENSED ELECTRICIAN.

USE NITRILE GLOVES TO HANDLE THE COMPONENTS TO AVOID FINGERPRINTS.

ALL BRASS FINISHES ARE UNLACQUERED AND HAND SEALED WITH A LIGHT LAYER OF WAX.

THE FINISH IS LIVE AND IS INTENDED TO PATINA OVER TIME.

WE TRY OUR BEST FOR ALL GOODS TO LEAVE OUR PREMISES IN PRISTINE CONDITION, BUT SOMETIMES PRODUCTS MAY ARRIVE WITH MINOR OXIDISATION MARKS, REVEALING THE HIGH CRAFTSMANSHIP PROCESS.

GLASS ASSEMBLY

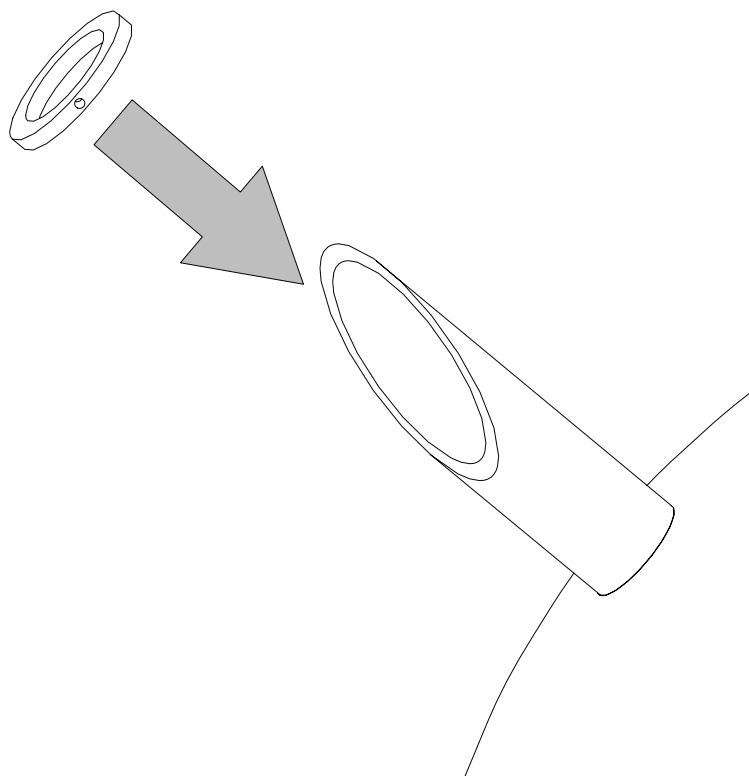

10 - LFIT THE RING ON THE ROD.

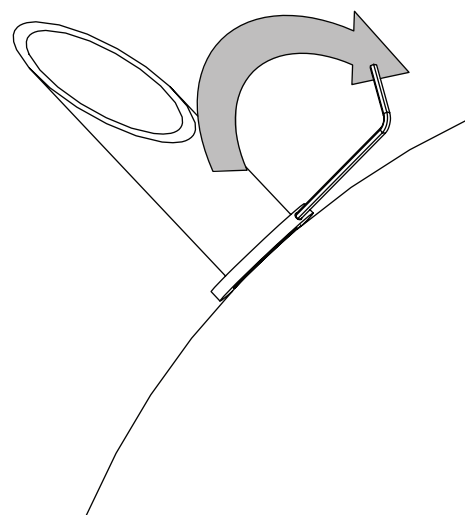

11 - GENTLY SECURE THE RING IN PLACE
USING THE PROVIDED 1,5MM ALLEN-KEY.

NOTE

PLEASE CONTACT A LICENSED ELECTRICIAN.

USE NITRILE GLOVES TO HANDLE THE COMPONENTS TO AVOID FINGERPRINTS.

ALL BRASS FINISHES ARE UNLACQUERED AND HAND SEALED WITH A LIGHT LAYER OF WAX.

THE FINISH IS LIVE AND IS INTENDED TO PATINA OVER TIME.

WE TRY OUR BEST FOR ALL GOODS TO LEAVE OUR PREMISES IN PRISTINE CONDITION, BUT SOMETIMES PRODUCTS MAY ARRIVE WITH MINOR OXIDISATION MARKS, REVEALING THE HIGH CRAFTSMANSHIP PROCESS.