

SilvioMondinoStudio

Lune Light (US)
Installation Guide - Rev. 01/20

COMPONENTS

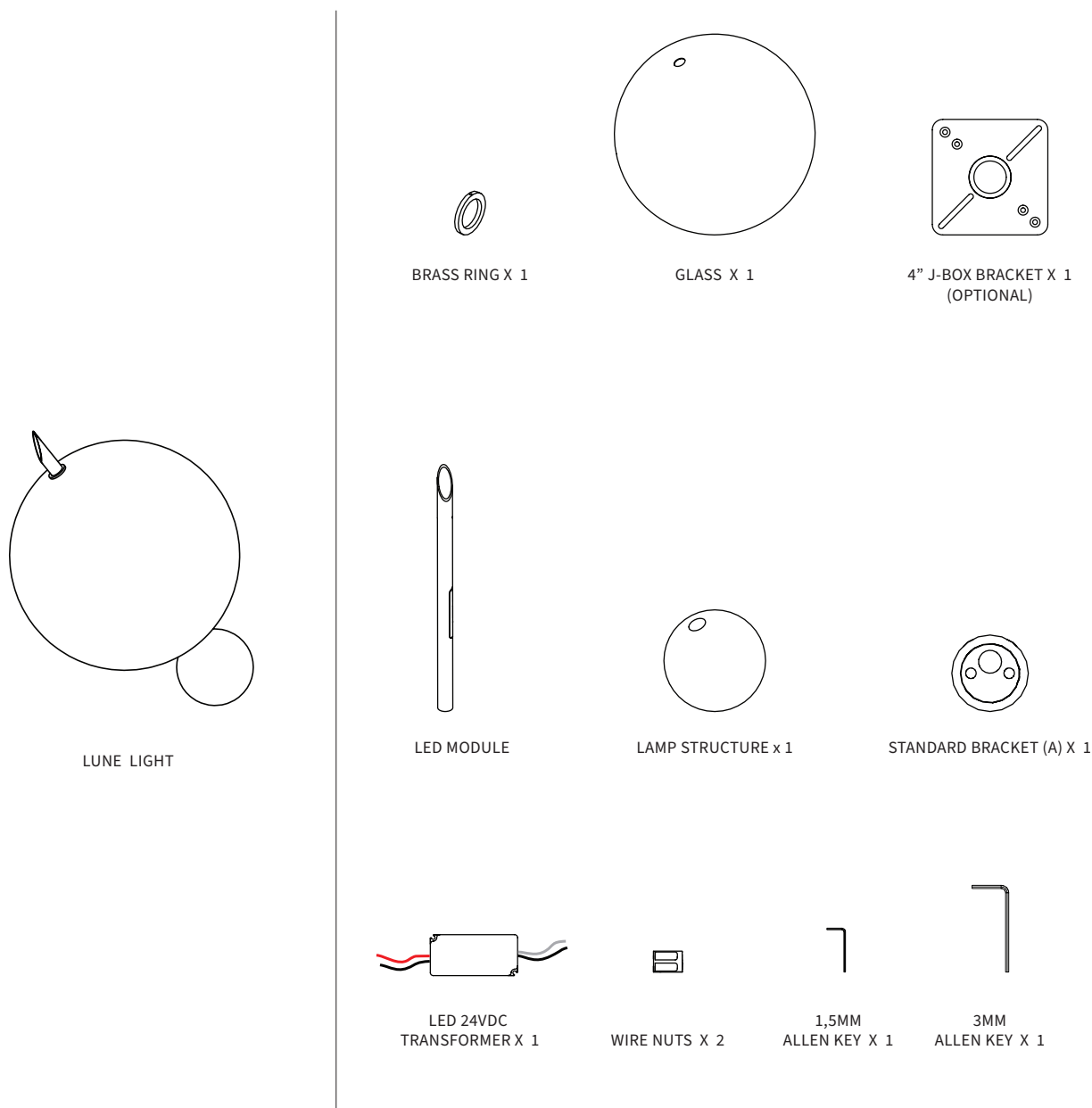

SAFETY INFORMATION

ONLY SUITABLE TO BE WALL MOUNTED VERTICALLY.
ONLY SUITABLE FOR DIRECT MOUNTING ON NON-COMBUSTIBLE SURFACES.
SUITABLE FOR DRY, INDOOR USE ONLY.
MAXIMUM AMBIENT TEMPERATURE: 30°C
THE CLIENT IS RESPONSIBLE TO ENSURE THAT THE WALL/CEILING HAS ADEQUATE STRUCTURAL SUPPORT FOR THE LAMP.

STANDARD - BRACKET ASSEMBLY

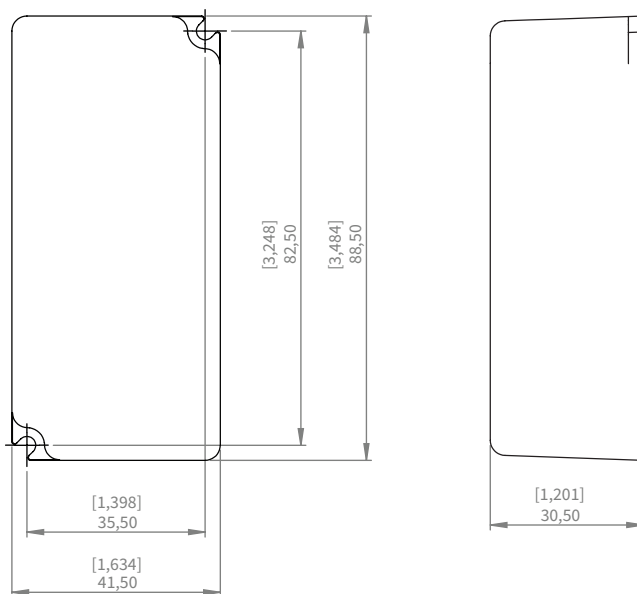
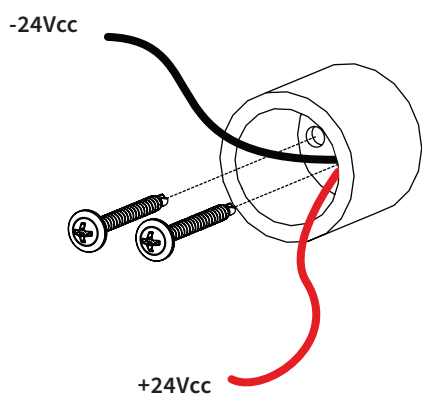

1A - PLACE THE BRACKET ON THE WALL USING APPROPRIATE SCREWS. ENSURE THE WALL/CEILING HAS ADEQUATE STRUCTURAL SUPPORT FOR THE BRACKET AND THE LAMP WEIGHT. MAKE SURE 24VDC TRANSFORMER WIRES ARE PULLED OUT FROM THE CENTRAL HOLE

THE TRANSFORMER MUST BE PLACED REMOTELY.

LED DRIVER:
 INPUT: 120 VAC - 50/60 HZ - 0,42A
 OUTPUT: 24VDC - 1A
 CONSTANT VOLTAGE PHASE DIMMING FOR FORWARD PHASE, MAGNETIC LOW VOLTAGE AND TRIAC DIMMERS

NOTE

PLEASE CONTACT A LICENSED ELECTRICIAN.
 USE NITRILE GLOVES TO HANDLE THE COMPONENTS TO AVOID FINGERPRINTS.
 ALL BRASS FINISHES ARE UNLACQUERED AND HAND SEALED WITH A LIGHT LAYER OF WAX.
 THE FINISH IS LIVE AND IS INTENDED TO PATINA OVER TIME.
 WE TRY OUR BEST FOR ALL GOODS TO LEAVE OUR PREMISES IN PRISTINE CONDITION, BUT SOMETIMES PRODUCTS MAY ARRIVE WITH MINOR OXIDISATION MARKS, REVEALING THE HIGH CRAFTSMANSHIP PROCESS.

(OPTIONAL) J-BOX - BRACKET ASSEMBLY

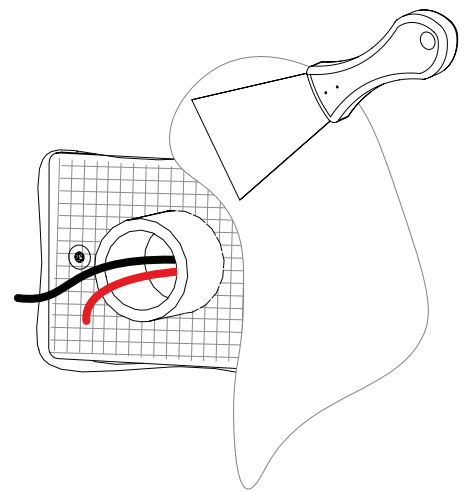
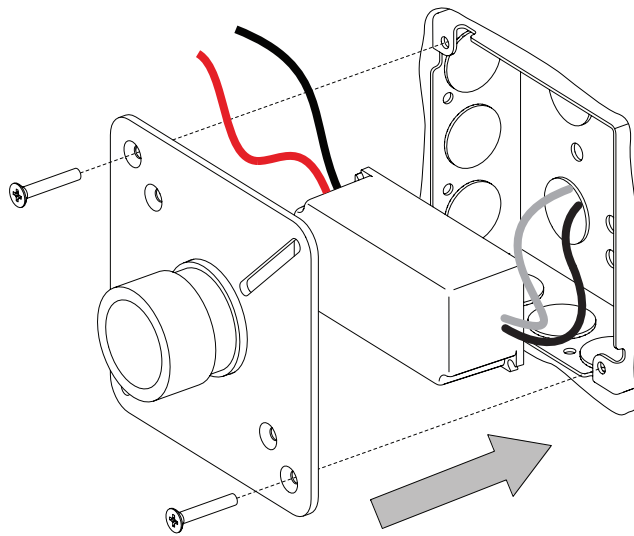

1B - CONNECT THE N-L INPUT OF THE TRANSFORMER TO THE ELECTRICAL SYSTEM AND PLACE IT INTO THE JUNCTION BOX.

WRONG CONNECTION WILL DAMAGE IRREPARABLY THE TRANSFORMER.

2B - SECURE THE BRACKET TO THE 4" J-BOX USING APPROPRIATE SCREWS.

ENSURE THE WALL/CEILING HAS ADEQUATE STRUCTURAL SUPPORT FOR THE BRACKET AND THE LAMP WEIGHT

3B - PLASTER THE WALL AND COVER THE BRACKET. (PLACE ADHESIVE GAUZE STRIPS ON THE BRACKET BEFORE FILL WITH PLASTER)

MAKE SURE 24VCC TRANSFORMER WIRES ARE PULLED OUT FROM THE CENTRAL HOLE.

NOTE

PLEASE CONTACT A LICENSED ELECTRICIAN.

USE NITRILE GLOVES TO HANDLE THE COMPONENTS TO AVOID FINGERPRINTS.

ALL BRASS FINISHES ARE UNLACQUERED AND HAND SEALED WITH A LIGHT LAYER OF WAX.

THE FINISH IS LIVE AND IS INTENDED TO PATINA OVER TIME.

WE TRY OUR BEST FOR ALL GOODS TO LEAVE OUR PREMISES IN PRISTINE CONDITION, BUT SOMETIMES PRODUCTS MAY ARRIVE WITH MINOR OXIDISATION MARKS, REVEALING THE HIGH CRAFTSMANSHIP PROCESS.

LAMP ASSEMBLY

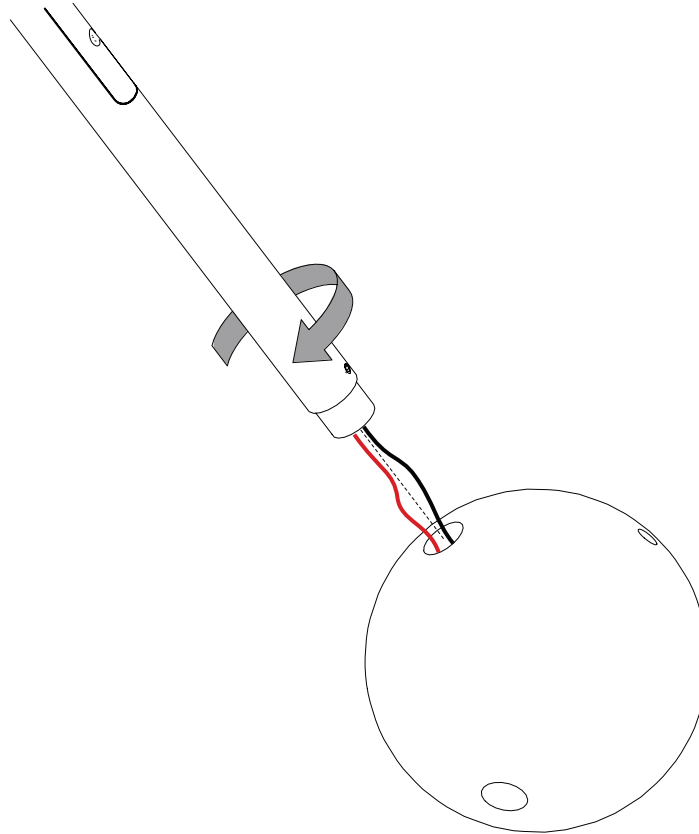

-
- 1 - GENTLY SCREW THE ROD INTO THE BRASS SPHERE PUTTING THE CABLES INTO THE SPHERE HOLE.
 - 2 - DO THE SAME FOR THE REMAINING RODS.

NOTE

PLEASE CONTACT A LICENSED ELECTRICIAN.
USE NITRILE GLOVES TO HANDLE THE COMPONENTS TO AVOID FINGERPRINTS.
ALL BRASS FINISHES ARE UNLACQUERED AND HAND SEALED WITH A LIGHT LAYER OF WAX.
THE FINISH IS LIVE AND IS INTENDED TO PATINA OVER TIME.
WE TRY OUR BEST FOR ALL GOODS TO LEAVE OUR PREMISES IN PRISTINE CONDITION, BUT SOMETIMES PRODUCTS MAY ARRIVE WITH MINOR OXIDISATION MARKS, REVEALING THE HIGH CRAFTSMANSHIP PROCESS.

LAMP PLACEMENT

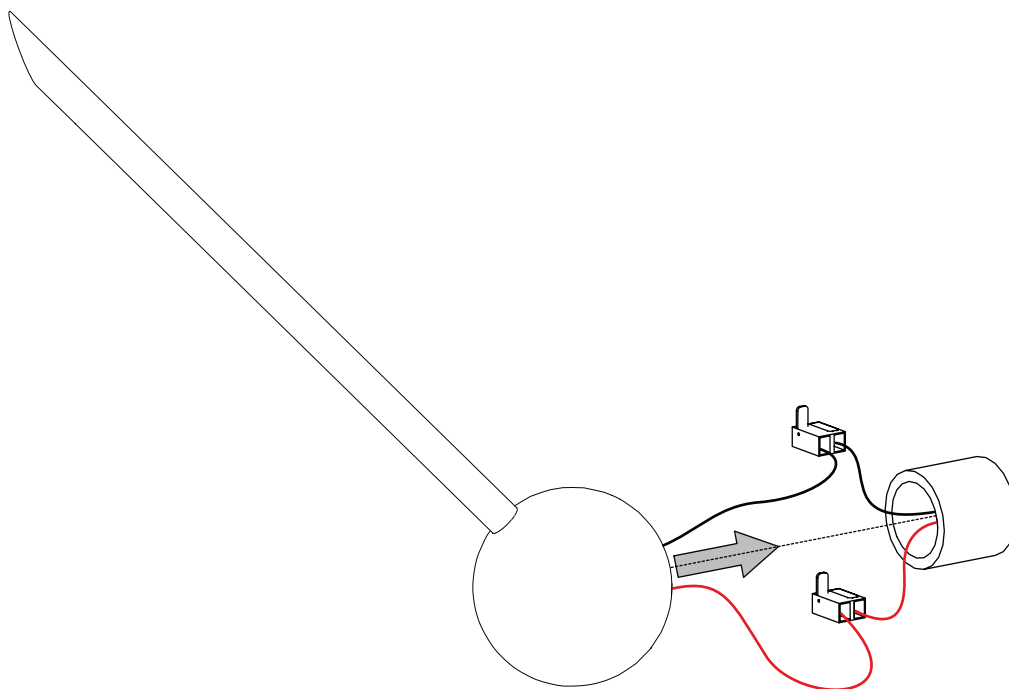

3 - MAKE ELECTRICAL CONNECTIONS PAYING ATTENTION TO THE POLARITY. (RED +24Vcc)
JOIN THE TWO RED WIRES AND CONNECT AT THE WIRE NUT. DO THE SAME WITH THE BLACKS.

WRONG CONNECTION WILL DAMAGE IRREPARABLY THE LED MODULE.

4 - PUSH THE WIRES BACK THROUGH THE CENTRAL HOLE AND FIT THE LAMP ON THE BRACKET WHILE CAREFULLY HOLDING FIXTURE

NOTE

PLEASE CONTACT A LICENSED ELECTRICIAN.

USE NITRILE GLOVES TO HANDLE THE COMPONENTS TO AVOID FINGERPRINTS.

ALL BRASS FINISHES ARE UNLACQUERED AND HAND SEALED WITH A LIGHT LAYER OF WAX.

THE FINISH IS LIVE AND IS INTENDED TO PATINA OVER TIME.

WE TRY OUR BEST FOR ALL GOODS TO LEAVE OUR PREMISES IN PRISTINE CONDITION, BUT SOMETIMES PRODUCTS MAY ARRIVE WITH MINOR OXIDISATION MARKS, REVEALING THE HIGH CRAFTSMANSHIP PROCESS.

LAMP PLACEMENT

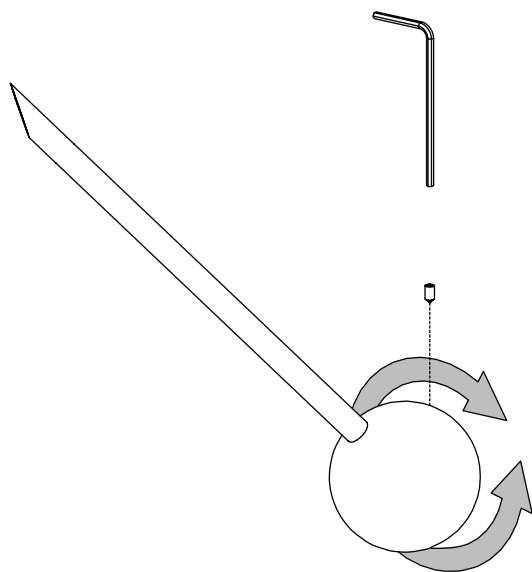

4 - ROTATE THE LAMP BODY IN THE RIGHT POSITION.

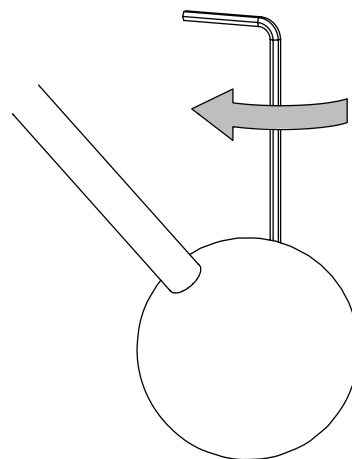

5 - SECURE IN PLACE WITH SET SCREWS ON TOP USING THE PROVIDED 3MM ALLEN-KEY

NOTE

PLEASE CONTACT A LICENSED ELECTRICIAN.

USE NITRILE GLOVES TO HANDLE THE COMPONENTS TO AVOID FINGERPRINTS.

ALL BRASS FINISHES ARE UNLACQUERED AND HAND SEALED WITH A LIGHT LAYER OF WAX.

THE FINISH IS LIVE AND IS INTENDED TO PATINA OVER TIME.

WE TRY OUR BEST FOR ALL GOODS TO LEAVE OUR PREMISES IN PRISTINE CONDITION, BUT SOMETIMES PRODUCTS MAY ARRIVE WITH MINOR OXIDISATION MARKS, REVEALING THE HIGH CRAFTSMANSHIP PROCESS.

GLASS ASSEMBLY

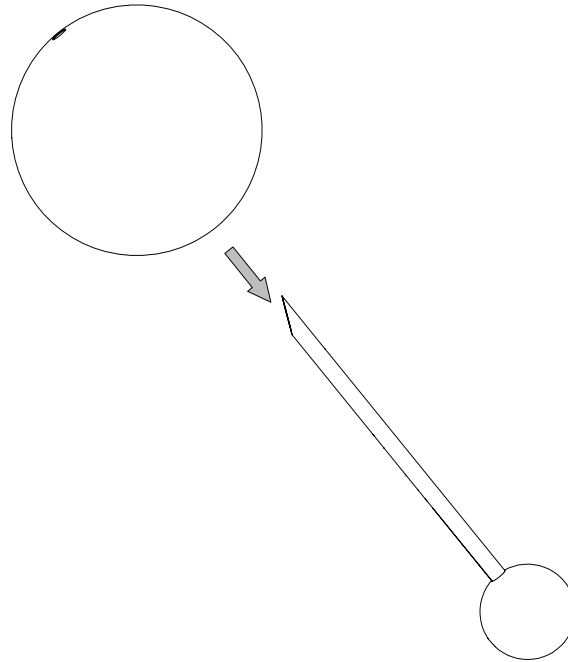

7 - FIT THE GLASS ONTO THE ROD.

NOTE

PLEASE CONTACT A LICENSED ELECTRICIAN.

USE NITRILE GLOVES TO HANDLE THE COMPONENTS TO AVOID FINGERPRINTS.

ALL BRASS FINISHES ARE UNLACQUERED AND HAND SEALED WITH A LIGHT LAYER OF WAX.

THE FINISH IS LIVE AND IS INTENDED TO PATINA OVER TIME.

WE TRY OUR BEST FOR ALL GOODS TO LEAVE OUR PREMISES IN PRISTINE CONDITION, BUT SOMETIMES PRODUCTS MAY ARRIVE WITH MINOR OXIDISATION MARKS REVEALING THE HIGH CRAFTSMANSHIP PROCESS.

GLASS ASSEMBLY

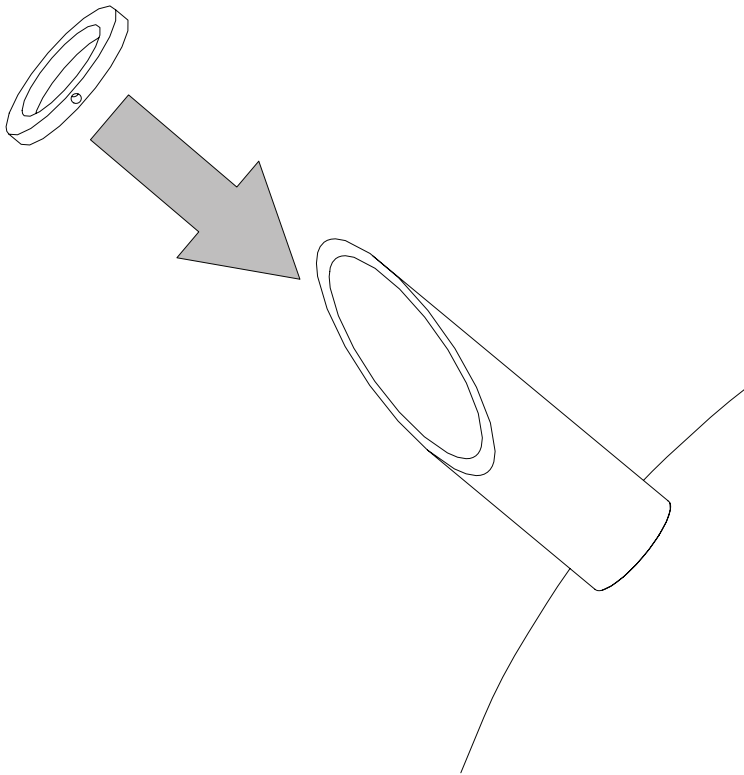

9 - FIT THE RING ON THE ROD.

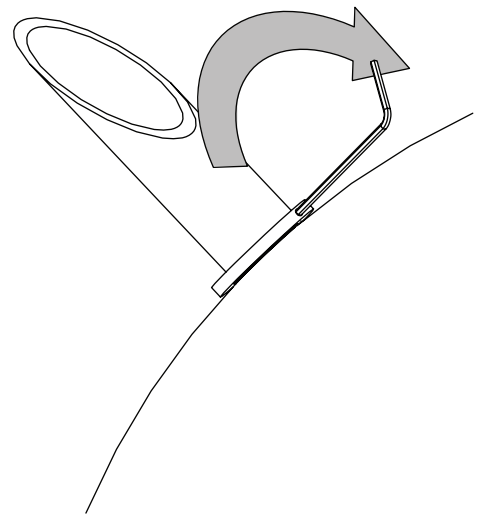

11 - GENTLY SECURE THE RING IN PLACE USING THE PROVIDED 1,5MM ALLEN-KEY.

NOTE

PLEASE CONTACT A LICENSED ELECTRICIAN.
USE NITRILE GLOVES TO HANDLE THE COMPONENTS TO AVOID FINGERPRINTS.
ALL BRASS FINISHES ARE UNLACQUERED AND HAND SEALED WITH A LIGHT LAYER OF WAX.
THE FINISH IS LIVE AND IS INTENDED TO PATINA OVER TIME.
WE TRY OUR BEST FOR ALL GOODS TO LEAVE OUR PREMISES IN PRISTINE CONDITION, BUT SOMETIMES PRODUCTS MAY ARRIVE WITH MINOR OXIDISATION MARKS.