

SilvioMondinoStudio

Alpi / Alpina
Installation Guide - Rev. 01/20

COMPONENTS

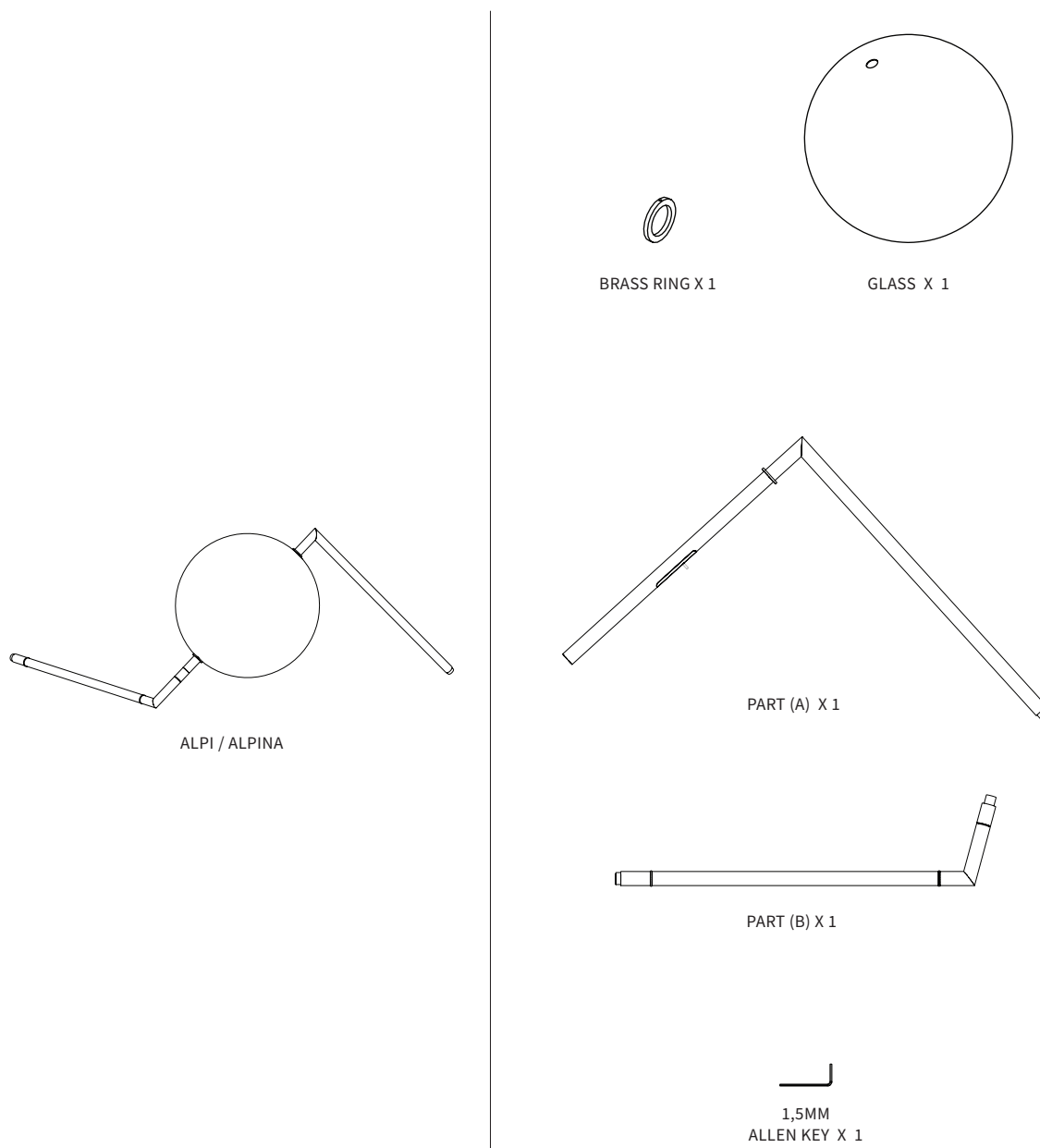

SAFETY INFORMATION

ONLY SUITABLE FOR DIRECT MOUNTING ON NON-COMBUSTIBLE SURFACES.
SUITABLE FOR DRY, INDOOR USE ONLY.
MAXIMUM AMBIENT TEMPERATURE: 30°C

GLASS ASSEMBLY

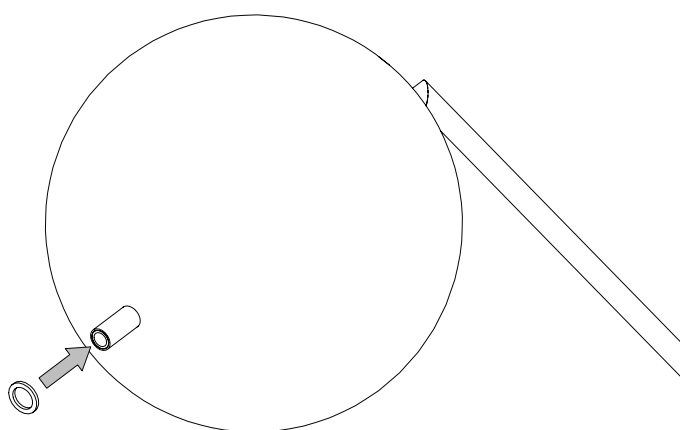

1 - FIT THE GLASS AND THE RING ON THE STEM (PART A).

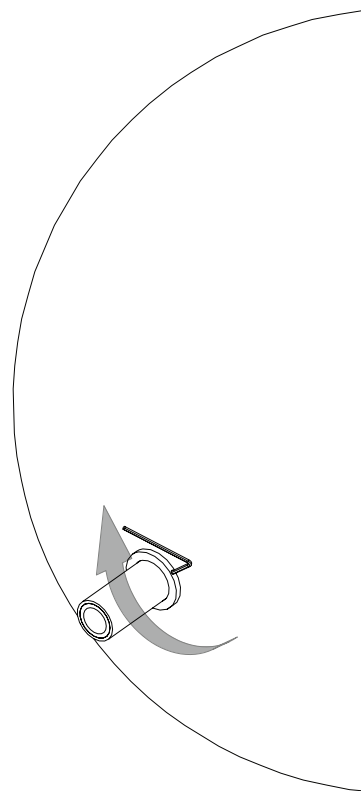

2 - LOCATE THE SET SCREWS HOUSING HOLE AND GENTLY BLOCK THE RING IN PLACE USING THE PROVIDED 1,5MM ALLEN-KEY.

NOTE

PLEASE CONTACT A LICENSED ELECTRICIAN.

USE NITRILE GLOVES TO HANDLE THE COMPONENTS TO AVOID FINGERPRINTS.

ALL BRASS FINISHES ARE UNLACQUERED AND HAND SEALED WITH A LIGHT LAYER OF WAX.

THE FINISH IS LIVE AND IS INTENDED TO PATINA OVER TIME.

WE TRY OUR BEST FOR ALL GOODS TO LEAVE OUR PREMISES IN PRISTINE CONDITION, BUT SOMETIMES PRODUCTS MAY ARRIVE WITH MINOR OXIDISATION MARKS, REVEALING THE HIGH CRAFTSMANSHIP PROCESS.

LAMP ASSEMBLY

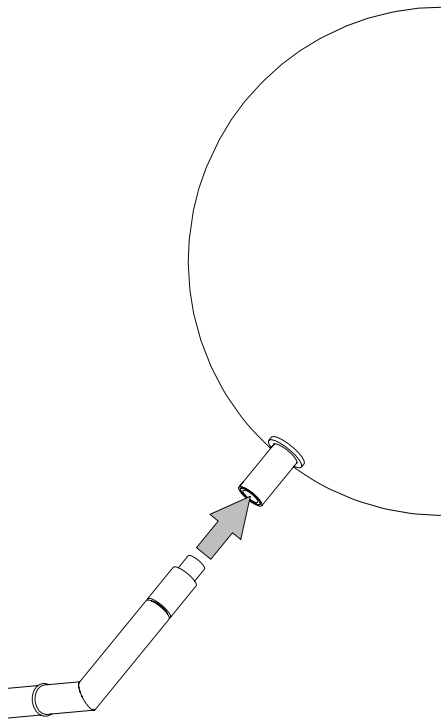

3 - INSERT PART (B) AS IN THE PICTURE.

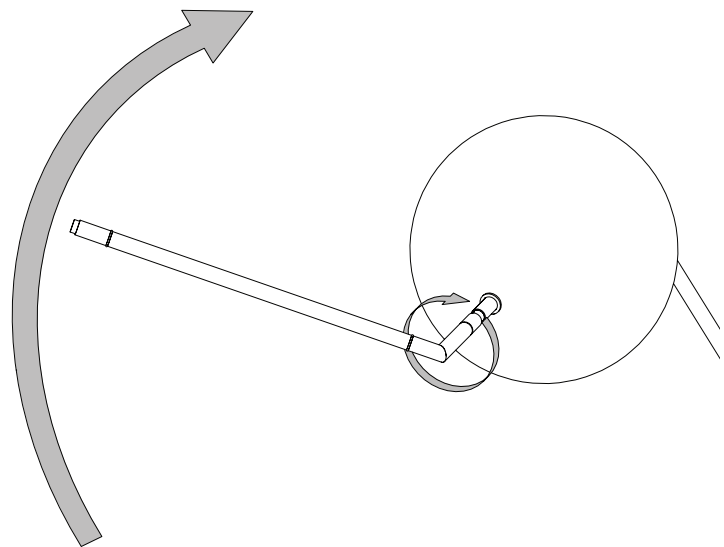

4 - GENTLY TURN THE PART (B) UNTIL IT IS SCREWED COMPLETELY, HOLDING THE PART (A) FIRMLY.

NOTE

PLEASE CONTACT A LICENSED ELECTRICIAN.

USE NITRILE GLOVES TO HANDLE THE COMPONENTS TO AVOID FINGERPRINTS.

ALL BRASS FINISHES ARE UNLACQUERED AND HAND SEALED WITH A LIGHT LAYER OF WAX.

THE FINISH IS LIVE AND IS INTENDED TO PATINA OVER TIME.

WE TRY OUR BEST FOR ALL GOODS TO LEAVE OUR PREMISES IN PRISTINE CONDITION, BUT SOMETIMES PRODUCTS MAY ARRIVE WITH MINOR OXIDISATION MARKS, REVEALING THE HIGH CRAFTSMANSHIP PROCESS.

ADJUSTING THE POSITION OF THE LAMP

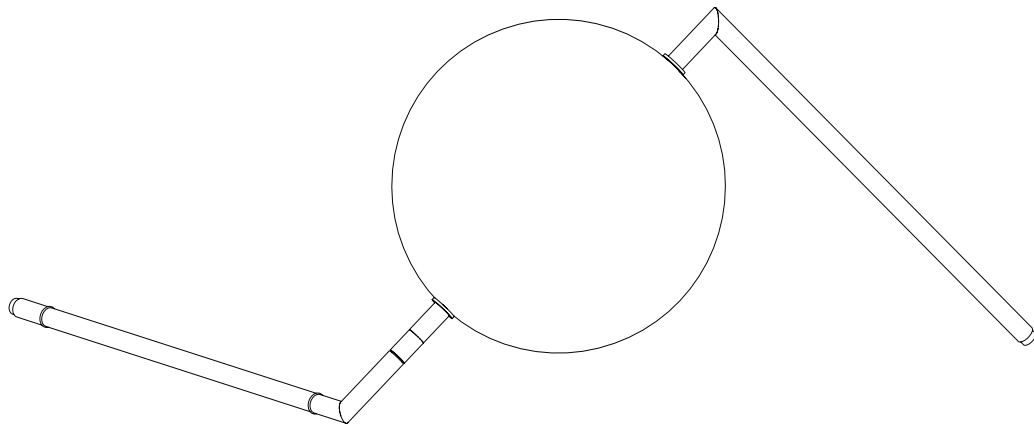

NOTE

PLEASE CONTACT A LICENSED ELECTRICIAN.

USE NITRILE GLOVES TO HANDLE THE COMPONENTS TO AVOID FINGERPRINTS.

ALL BRASS FINISHES ARE UNLACQUERED AND HAND SEALED WITH A LIGHT LAYER OF WAX.

THE FINISH IS LIVE AND IS INTENDED TO PATINA OVER TIME.

WE TRY OUR BEST FOR ALL GOODS TO LEAVE OUR PREMISES IN PRISTINE CONDITION, BUT SOMETIMES PRODUCTS MAY ARRIVE WITH MINOR OXIDISATION MARKS, REVEALING THE HIGH CRAFTSMANSHIP PROCESS.