

SilvioMondinoStudio

Trapezi Six Elements
Installation Guide - Rev. 01/23

COMPONENTS

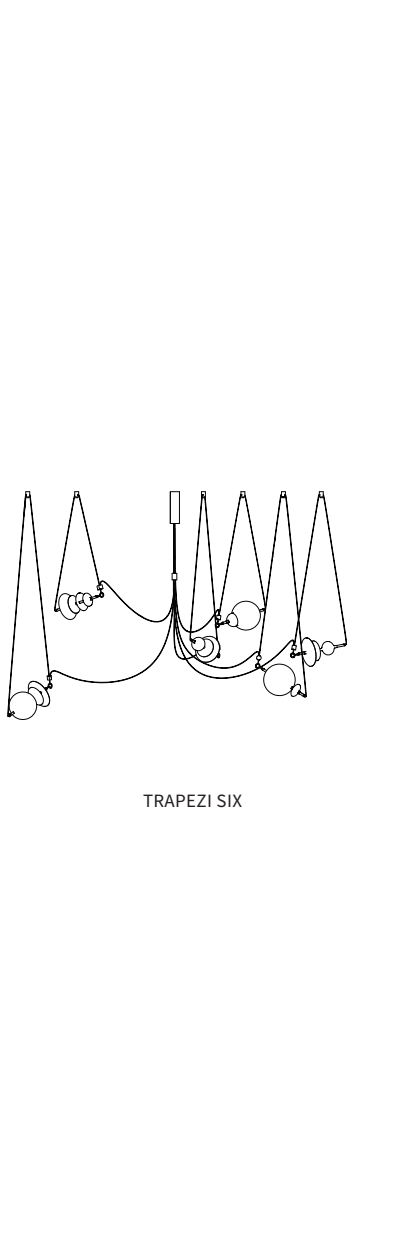

CABLE BLOCKER X 1

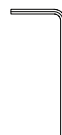

2 mm
ALLEN KEY X 1

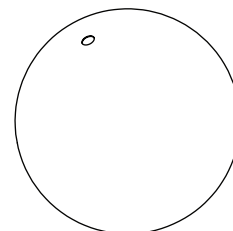

GLASS X VARIOUS



BRASS RING X 12



1,5 mm
ALLEN KEY X 1



CABLE RING X 1



M3 SCREW X 2

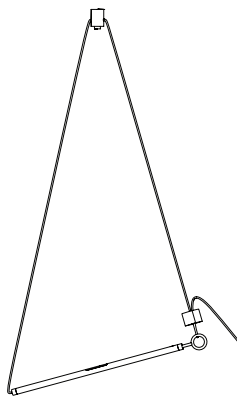

LAMP STRUCTURE x 6

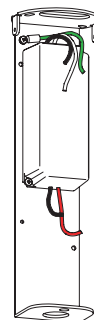

CEILING LED DRIVER X 1

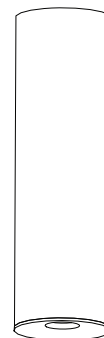

CANOPY X 1

SAFETY INFORMATION

ONLY SUITABLE FOR DIRECT MOUNTING ON NON-COMBUSTIBLE SURFACES.
SUITABLE FOR DRY, INDOOR USE ONLY.
MAXIMUM AMBIENT TEMPERATURE: 30°C

CEILING INSTALLATION

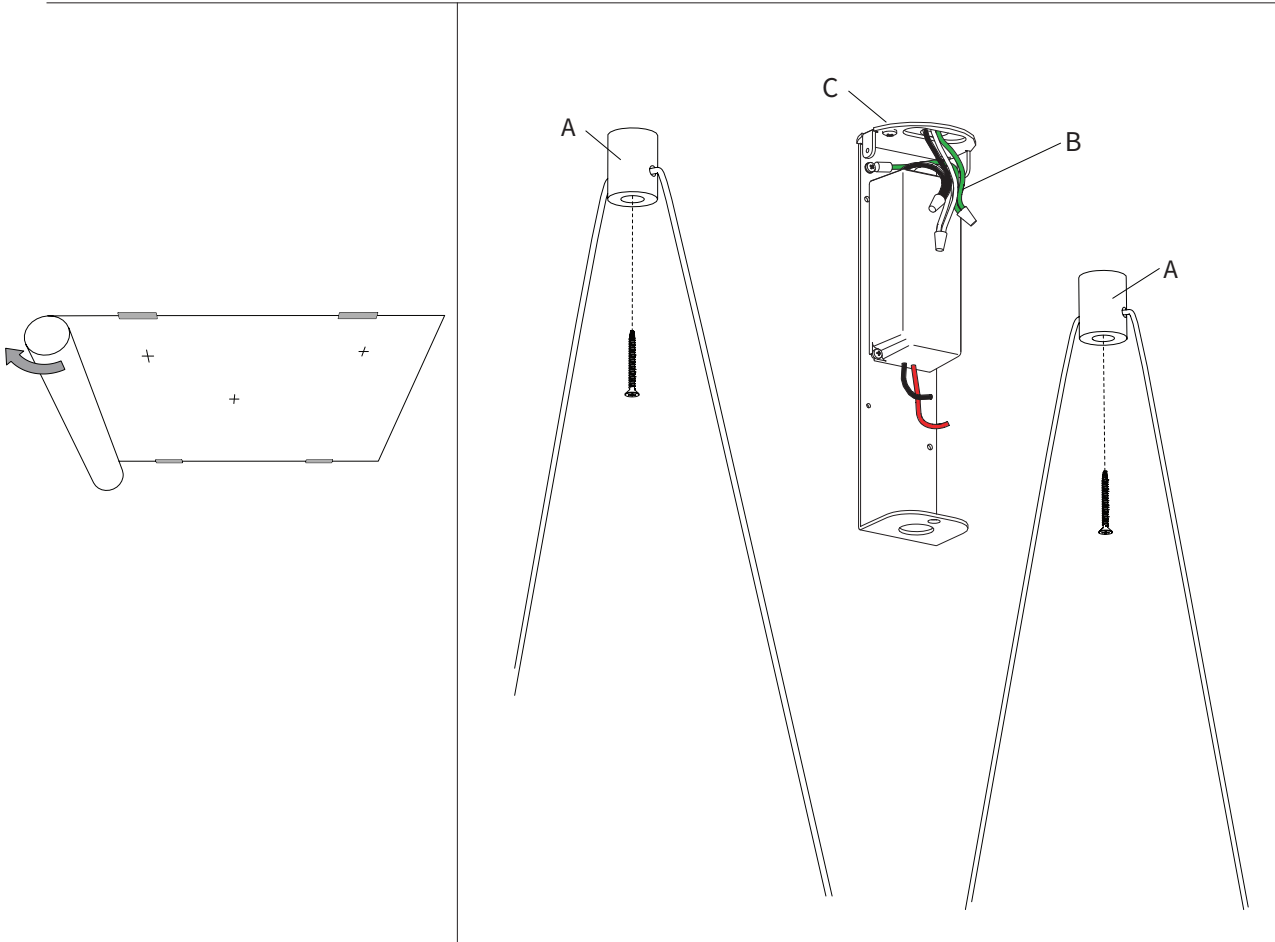

1 - TAPE PROVIDED 1:1 PRINTED TEMPLATE TO CEILING AT DESIRED LOCATION.

- EACH ANCHOR POINT SHOULD BE CAPABLE OF SUPPORTING 8 LBS, AND THEREFORE ADEQUATE SCREWS ARE REQUIRED FOR PROPER SUPPORT AT THE LOCATION OF EACH MALE MONO-POINT.

2 - LOCK IN PLACE EACH CANOPY (A) AND THE DRIVER BRACKET (C) TO THE CEILING, FOLLOWING THE 1:1 DIAGRAM SUPPLIED.

3 - CONNECT THE N-L INPUT OF THE LED DRIVER AND GREEN GROUND WIRE (B) TO THE ELECTRICAL SYSTEM .

WRONG CONNECTION OR VOLTAGE WILL IRREPARABLY DAMAGE THE TRANSFORMER.

PLEASE CHECK THE INPUT AC VOLTAGE CAPABILITIES OF THE SUPPLIED LED DRIVER BEFORE PROCEEDING.

NOTE

PLEASE CONTACT A LICENSED ELECTRICIAN.

USE NITRILE GLOVES TO HANDLE THE COMPONENTS TO AVOID FINGERPRINTS.

ALL BRUSHED BRASS SURFACES ARE SEALED TO SLOW DOWN THE PATINA DURING THE TIME.

POLISHED BRASS SURFACES ARE "LIVE" AND CAN BE RE-POLISHED USING A POLISHING CREAM.

UNEVEN SURFACES ON OXIDIZED FINISHING ARE A CHARACTERISTIC OF UNICITY, REVEALING THE CRAFTSMANSHIP PROCESS.

CEILING INSTALLATION

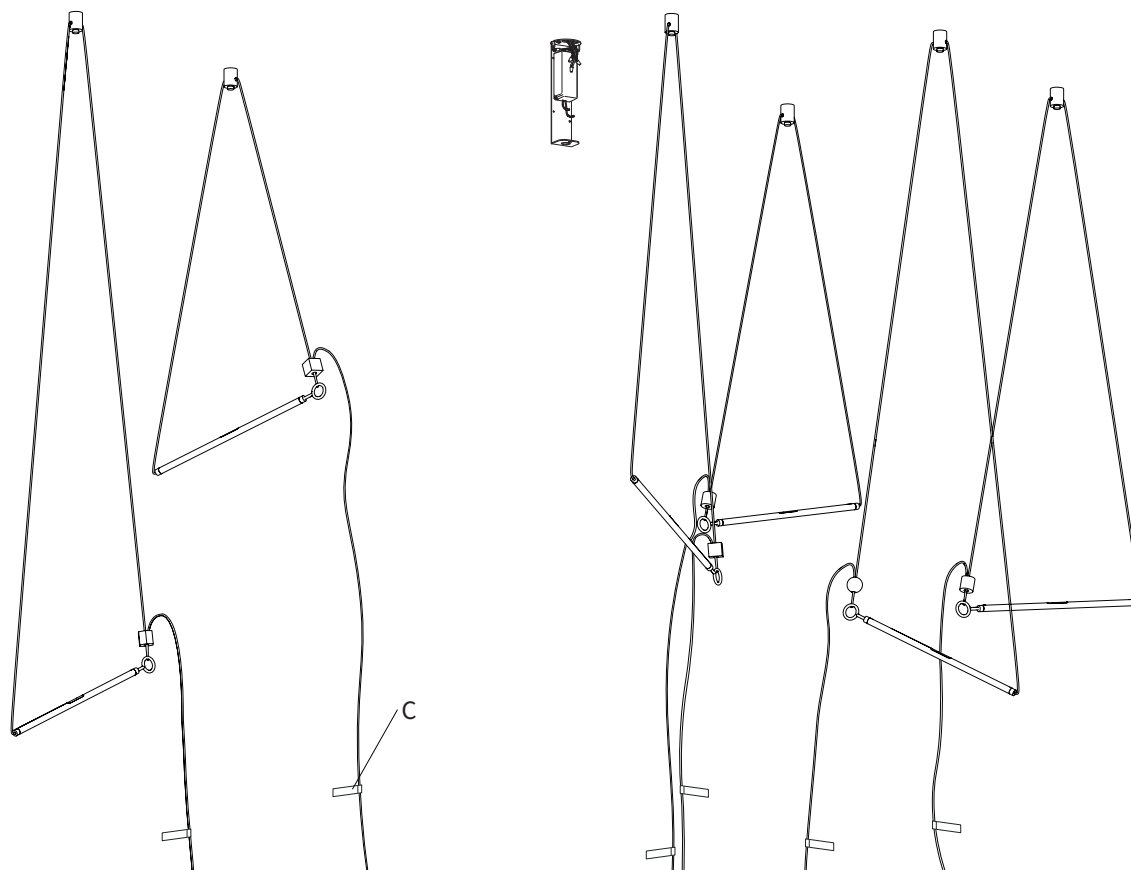

4 - HANG ALL THE ELEMENTS LEAVING THE CABLES DOWNWARDS AS PICTURED.

**STRAIGHTEN EACH PENDING CABLE BY REMOVING ANY TWISTS OR KINKS.
BRAIDED CABLE TENDS TO TWIST UPON ITSELF IF NOT HANDLED WITH CARE.**

ON EACH CABLE, THERE IS A LABEL (C) INDICATING THE SUGGESTED LOCKING POINT TO THE MAIN CANOPY TO ACHIEVE THE CURVATURE SHOWN IN THE FIGURE.

THESE LABELS ARE PROVIDED AS A REFERENCE TO FACILITATE INSTALLATION.

WE RECOMMEND CUTTING THE CABLE AT THE RIGHT POINT ONLY AFTER VERIFYING ON-SITE THE CORRECT LENGTH OF THE CABLE TO ACHIEVE A SOFT AND SMOOTH CABLE DROP FROM THE CANOPY TO EACH ELEMENT.

NOTE

PLEASE CONTACT A LICENSED ELECTRICIAN.

USE NITRILE GLOVES TO HANDLE THE COMPONENTS TO AVOID FINGERPRINTS.

ALL BRUSHED BRASS SURFACES ARE SEALED TO SLOW DOWN THE PATINA DURING THE TIME.

POLISHED BRASS SURFACES ARE "LIVE" AND CAN BE RE-POLISHED USING A POLISHING CREAM.

UNEVEN SURFACES ON OXIDIZED FINISHING ARE A CHARACTERISTIC OF UNICITY, REVEALING THE CRAFTSMANSHIP PROCESS.

GLASS INSTALLATION

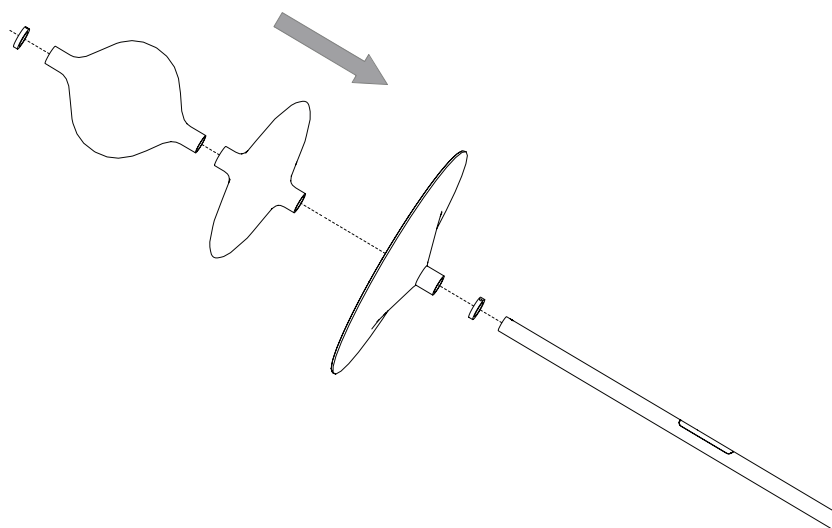

5 - SLIDE ALL THE GLASS AND THE RINGS ON THE BRASS ROD.
PLEASE REFER TO THE GLASS CONFIGURATION GUIDE FOR THE CORRECT GLASS POSITIONING.

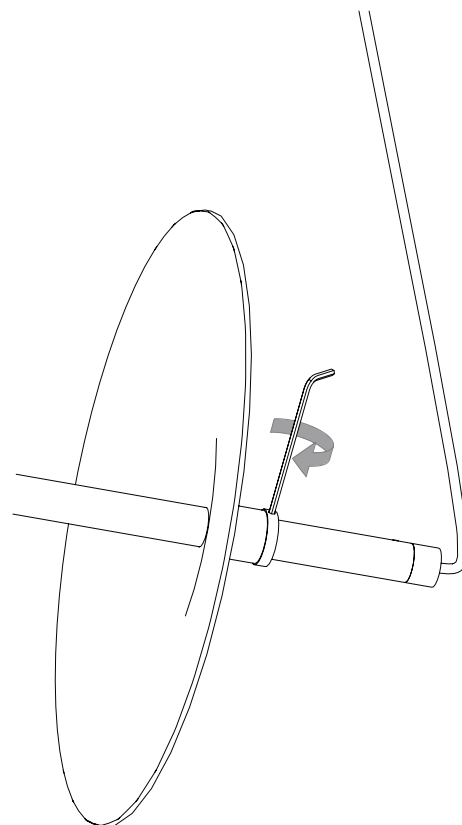

6 - LOCK IN PLACE THE GLASS WITH THE BRASS RINGS AND THE 1,5 MM ALLEN-KEY

NOTE

PLEASE CONTACT A LICENSED ELECTRICIAN.
USE NITRILE GLOVES TO HANDLE THE COMPONENTS TO AVOID FINGERPRINTS.
ALL BRUSHED BRASS SURFACES ARE SEALED TO SLOW DOWN THE PATINA DURING THE TIME.
POLISHED BRASS SURFACES ARE "LIVE" AND CAN BE RE-POLISHED USING A POLISHING CREAM.
UNEVEN SURFACES ON OXIDIZED FINISHING ARE A CHARACTERISTIC OF UNICITY, REVEALING THE CRAFTSMANSHIP PROCESS.

GLASS INSTALLATION

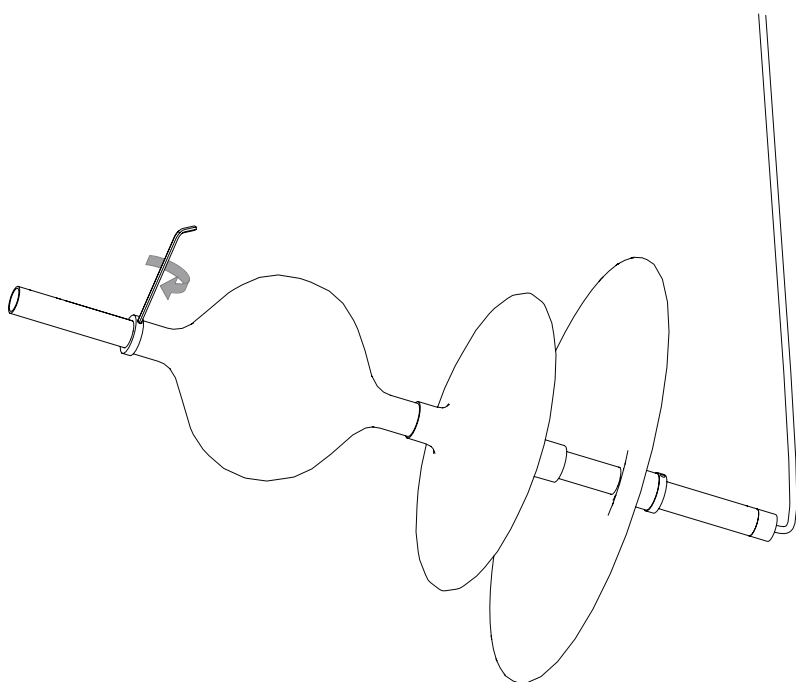

7 - LOCK IN PLACE THE GLASS WITH THE BRASS RINGS AND THE 1,5 MM ALLEN-KEY

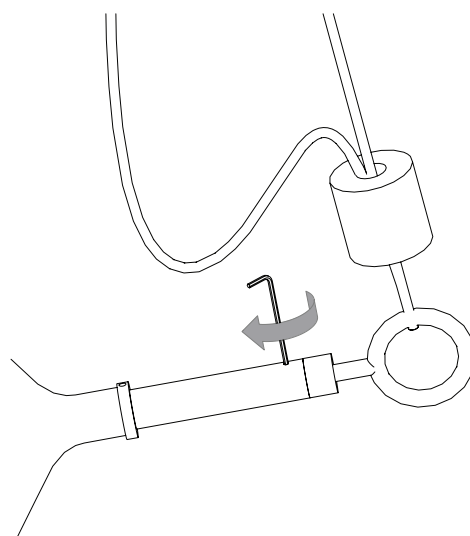

8 - LOCK IN PLACE THE WOODEN CAP WITH THE 1,5MM ALLEN-KEY.

NOTE

PLEASE CONTACT A LICENSED ELECTRICIAN.

USE NITRILE GLOVES TO HANDLE THE COMPONENTS TO AVOID FINGERPRINTS.

ALL BRUSHED BRASS SURFACES ARE SEALED TO SLOW DOWN THE PATINA DURING THE TIME.

POLISHED BRASS SURFACES ARE "LIVE" AND CAN BE RE-POLISHED USING A POLISHING CREAM.

UNEVEN SURFACES ON OXIDIZED FINISHING ARE A CHARACTERISTIC OF UNICITY, REVEALING THE CRAFTSMANSHIP PROCESS.

FINE TUNING

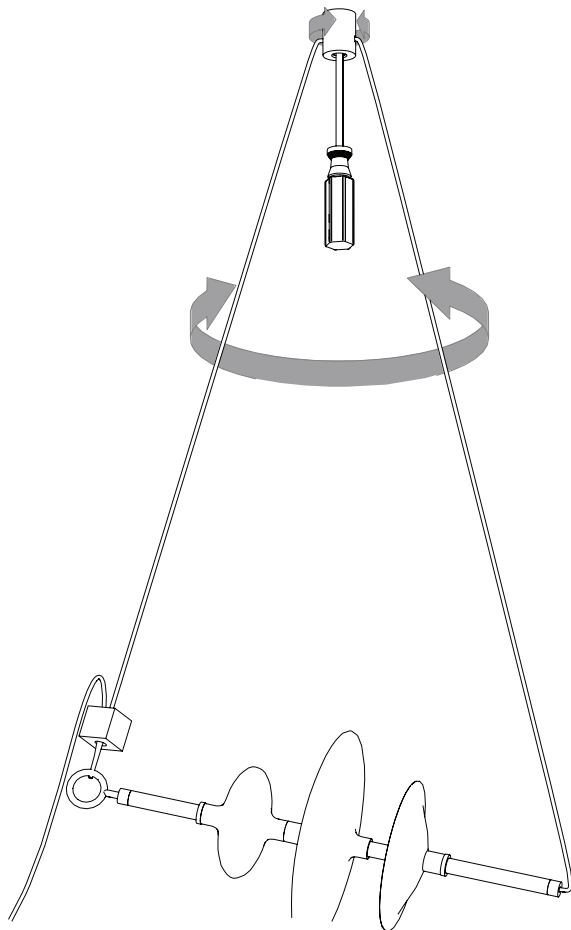

9 - FINE TUNE EACH ELEMENT ORIENTATION ROTATING THE ELEMENT CANOPY AND LOCK IT WITH THE ANCHOR SCREW

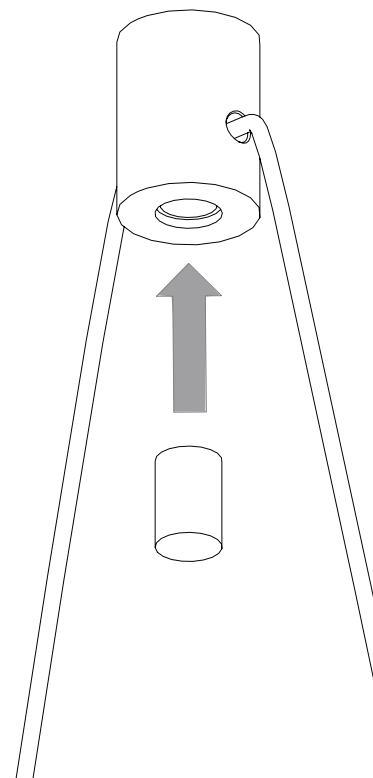

10- BLOCK THE ROPE IN POSITION WITH THE BRASS SCREW.

NOTE

PLEASE CONTACT A LICENSED ELECTRICIAN.

USE NITRILE GLOVES TO HANDLE THE COMPONENTS TO AVOID FINGERPRINTS.

ALL BRUSHED BRASS SURFACES ARE SEALED TO SLOW DOWN THE PATINA DURING THE TIME.

POLISHED BRASS SURFACES ARE "LIVE" AND CAN BE RE-POLISHED USING A POLISHING CREAM.

UNEVEN SURFACES ON OXIDIZED FINISHING ARE A CHARACTERISTIC OF UNICITY, REVEALING THE CRAFTSMANSHIP PROCESS.

CABLES SETTING

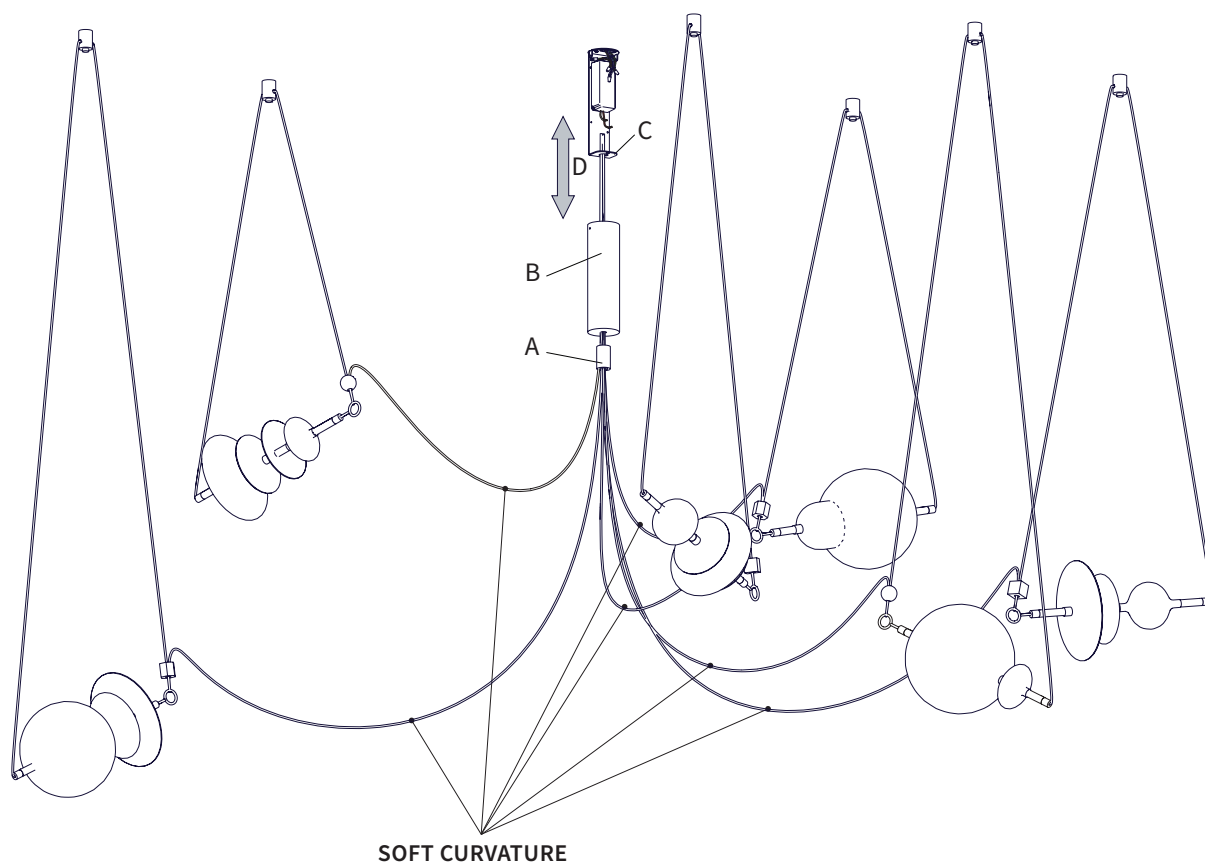

11 - SLIDE ALL ELEMENTS ROPES THROUGH THE CABLE RING (A) THE LED DRIVER CARTER (B) AND THE DRIVER BRACKET (C).

12 - RAISE AND LOWER EACH CABLE SEPARATELY UNTIL ACHIEVING A SOFT AND NATURAL CURVATURE FOR EACH ELEMENT (D)

NOTE

PLEASE CONTACT A LICENSED ELECTRICIAN.

USE NITRILE GLOVES TO HANDLE THE COMPONENTS TO AVOID FINGERPRINTS.

ALL BRUSHED BRASS SURFACES ARE SEALED TO SLOW DOWN THE PATINA DURING THE TIME.

POLISHED BRASS SURFACES ARE "LIVE" AND CAN BE RE-POLISHED USING A POLISHING CREAM.

UNEVEN SURFACES ON OXIDIZED FINISHING ARE A CHARACTERISTIC OF UNICITY, REVEALING THE CRAFTSMANSHIP PROCESS.

CEILING INSTALLATION

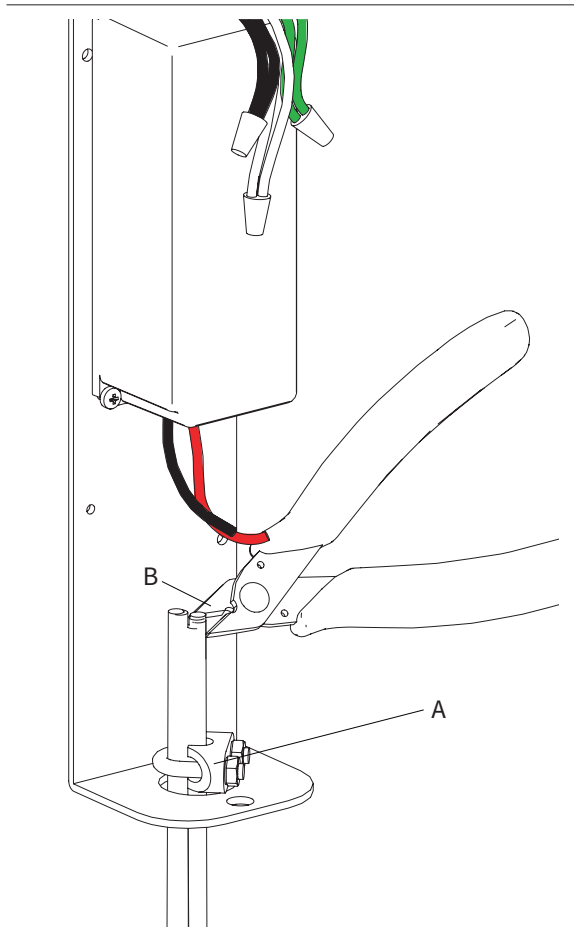

13 - ONCE THE CORRECT POSITION OF EACH CABLE HAS BEEN FOUND, FASTEN THE BUNCH OF ROPES AT THE BRACKET USING THE CABLE BLOCKER (A) PROVIDED.

14 - CUT THE ELECTRIC EXTRA WIRE

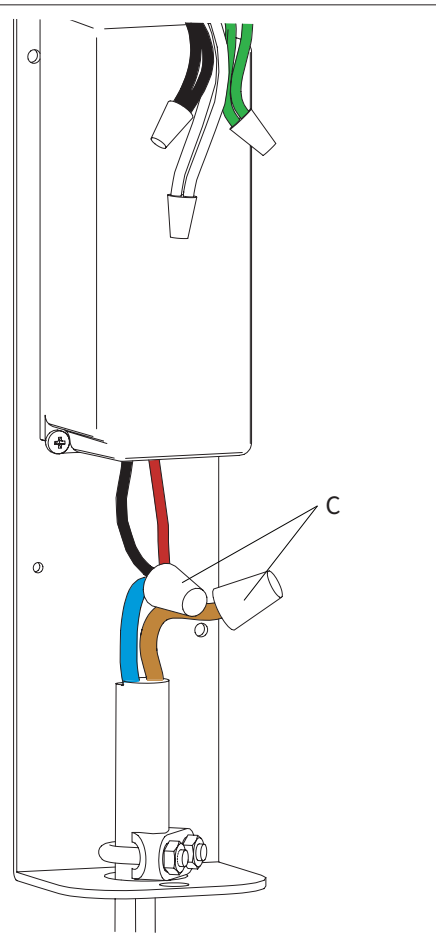

15 - MAKE ELECTRICAL CONNECTIONS (C) PAYING ATTENTION TO POLARITY. (RED/BROWN +24VCC) (BLACK/BLUE -24VCC)

JOIN THE RED/BROWN WIRES AND CONNECT AT THE WIRE NUT.

DO THE SAME WITH THE BLACK/BLUE.

WRONG CONNECTION MAY DAMAGE IRREPARABLY THE LED MODULES

NOTE

PLEASE CONTACT A LICENSED ELECTRICIAN.

USE NITRILE GLOVES TO HANDLE THE COMPONENTS TO AVOID FINGERPRINTS.

ALL BRUSHED BRASS SURFACES ARE SEALED TO SLOW DOWN THE PATINA DURING THE TIME.

POLISHED BRASS SURFACES ARE "LIVE" AND CAN BE RE-POLISHED USING A POLISHING CREAM.

UNEVEN SURFACES ON OXIDIZED FINISHING ARE A CHARACTERISTIC OF UNICITY, REVEALING THE CRAFTSMANSHIP PROCESS.

CEILING INSTALLATION

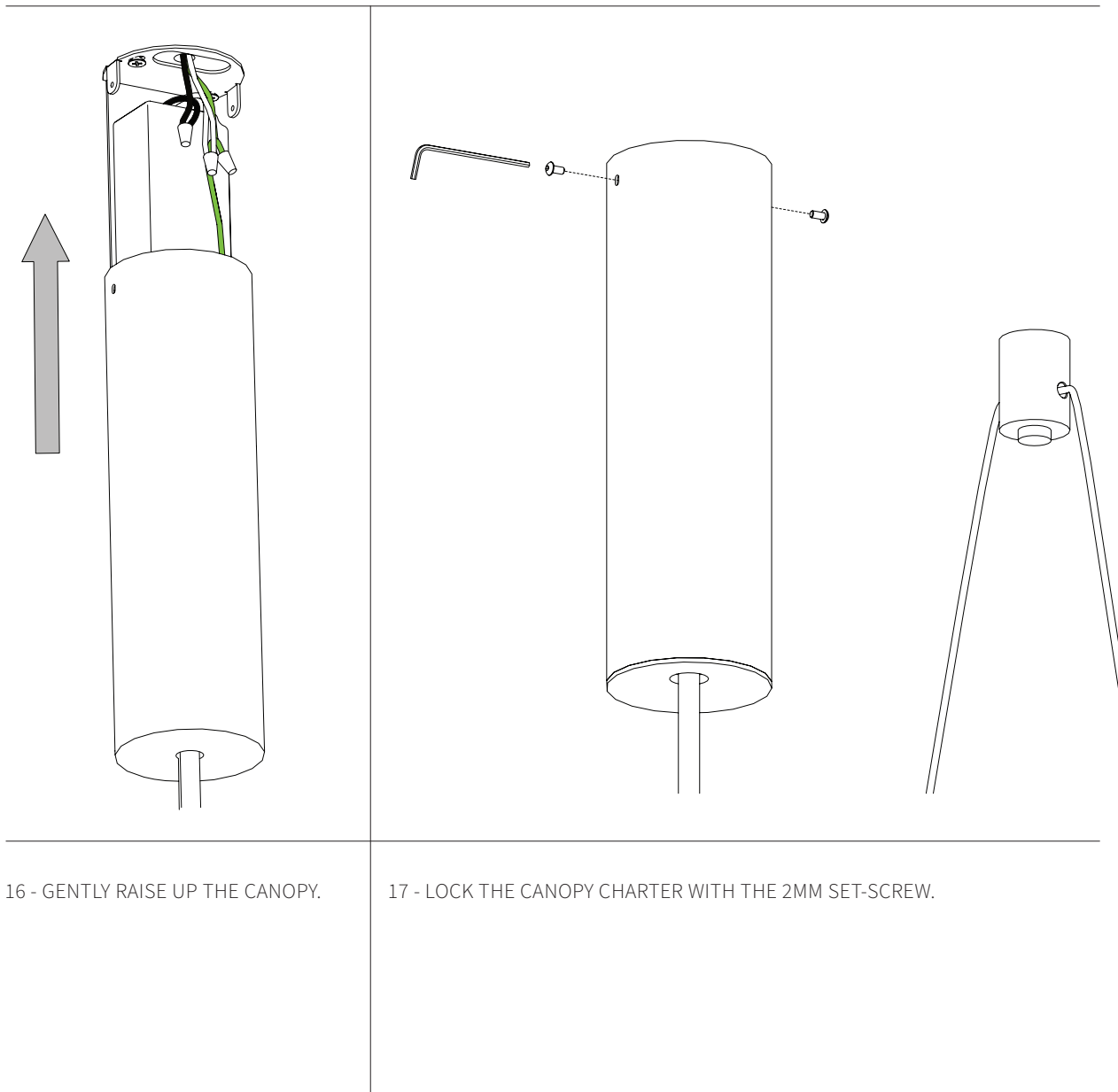

16 - GENTLY RAISE UP THE CANOPY.

17 - LOCK THE CANOPY CHARTER WITH THE 2MM SET-SCREW.

NOTE

PLEASE CONTACT A LICENSED ELECTRICIAN.
USE NITRILE GLOVES TO HANDLE THE COMPONENTS TO AVOID FINGERPRINTS.
ALL BRUSHED BRASS SURFACES ARE SEALED TO SLOW DOWN THE PATINA DURING THE TIME.
POLISHED BRASS SURFACES ARE "LIVE" AND CAN BE RE-POLISHED USING A POLISHING CREAM.
UNEVEN SURFACES ON OXIDIZED FINISHING ARE A CHARACTERISTIC OF UNICITY, REVEALING THE CRAFTSMANSHIP PROCESS.

REFERENCE

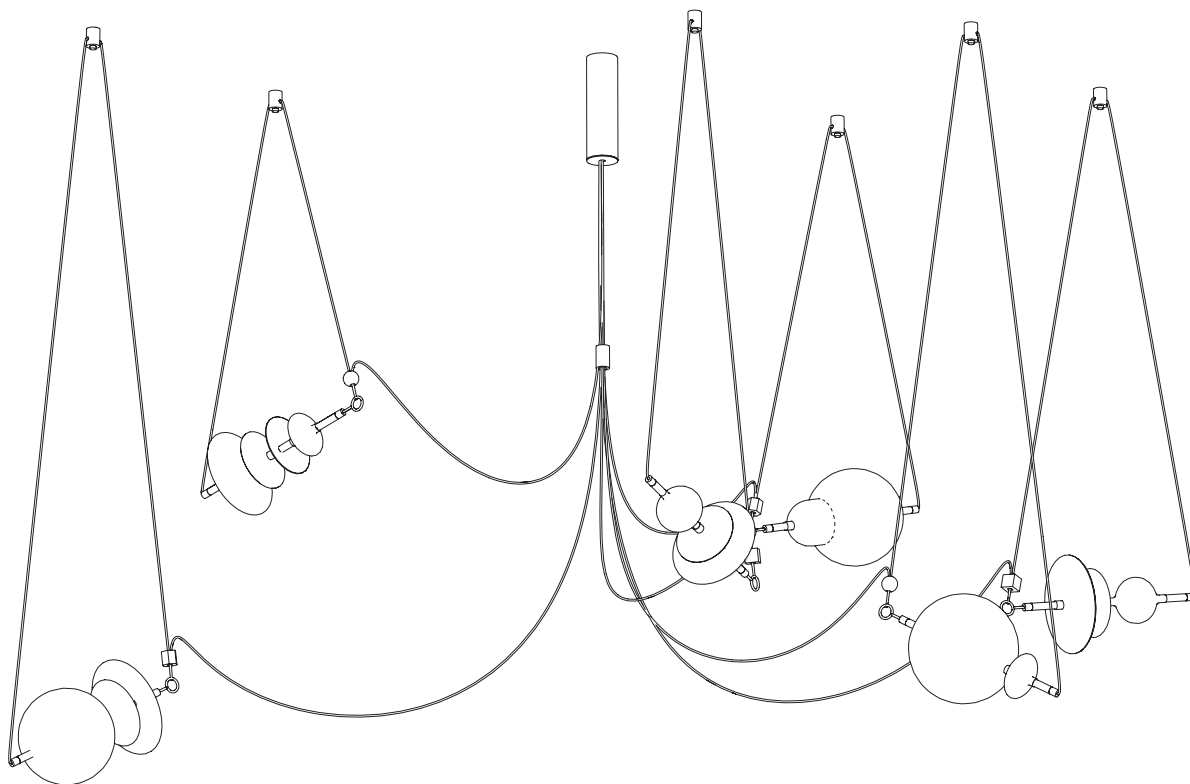

NOTE

PLEASE CONTACT A LICENSED ELECTRICIAN.

USE NITRILE GLOVES TO HANDLE THE COMPONENTS TO AVOID FINGERPRINTS.

ALL BRUSHED BRASS SURFACES ARE SEALED TO SLOW DOWN THE PATINA DURING THE TIME.

POLISHED BRASS SURFACES ARE "LIVE" AND CAN BE RE-POLISHED USING A POLISHING CREAM.

UNEVEN SURFACES ON OXIDIZED FINISHING ARE A CHARACTERISTIC OF UNICITY, REVEALING THE CRAFTSMANSHIP PROCESS.