



T-DOUBLE - TABLE LIGHT

T-DOUBLE SEEKS TO DEFINE A MORE INTIMATE SPACE WITHIN THE PERIMETER OF THE DESKTOP. TWO BRANCHES EMBRACE THE UPPER SPACE, WHILE THE MARQUINA MARBLE BASE CARVED BY ARTISANS FROM PIETRASANTA IN TUSCANY FEATURES A BARELY PERCEPTIBLE HOLLOW. THE DIRECTION OF EACH LED LIGHT CAN BE ADJUSTED TO SUIT, AND THE "ARM" CAN BE LOCKED IN POSITION

T-DOUBLE - TABLE LIGHT

DIMENSIONS: H 20" • 13" • 20,4" H 51CM • 32CM • 52CM

WEIGHT: 6,6LB • 3KG

MATERIALS: MACHINED BRASS, HAND-BLOWN GLASS,
BRAIDED CALFSKIN, MONGOY WOOD, MARQUINIA MARBLE

LIGHT SOURCE: PROPRIETARY 24VCC LED • 2 X 5W • 2700K

SUPPLY: PLUG-IN TRANSFORMER 100-240V 50/60HZ

LIGHT CONTROL: DIMMABLE BRAIDED CALFSKIN TOUCH
IN LINE ON-OFF SWITCH ON REQUEST

METAL OPTIONS:

POLISHED BRASS, BRUSHED BRASS

BLACKENED BRASS, AGED BRASS, BRUSHED NICKEL

TARNISHED SILVER

GLASS OPTIONS:

CLEAR, STARDUST WHITE

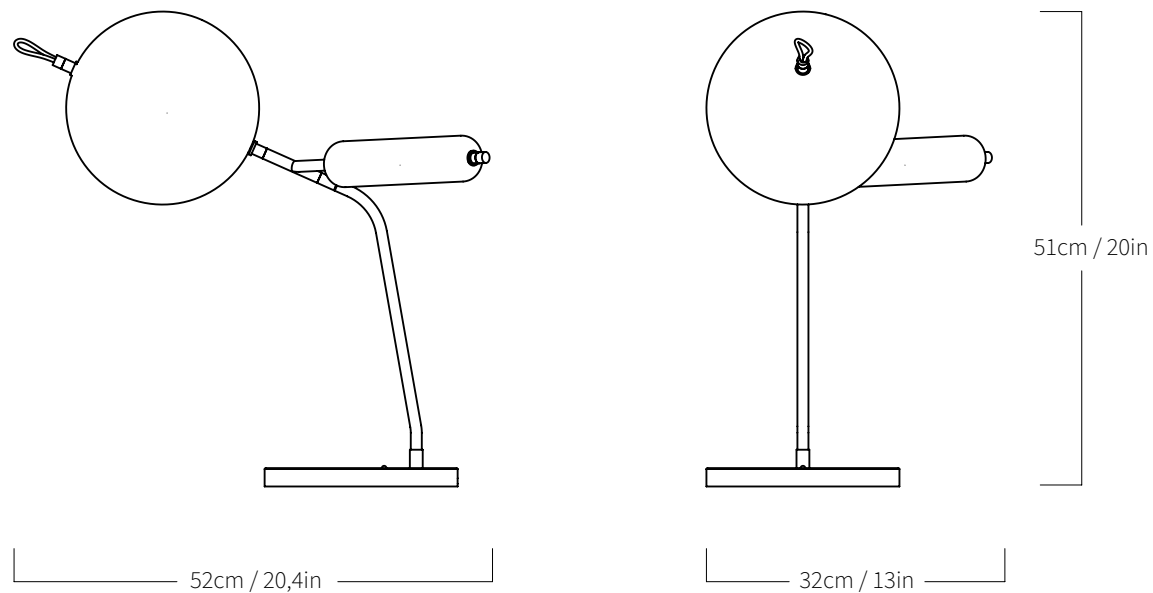

EACH PIECE IS MADE TO ORDER BY ITALIAN ARTISANS, FINISHED,
AND ASSEMBLED IN OUR STUDIO IN ITALY. CUSTOMIZATIONS
ARE AVAILABLE. ALL FINISHES CAN BE LACQUERED ON
REQUEST.
CUSTOM ORDERS REQUIRE A 50% NON-REFUNDABLE DEPOSIT.

METAL FINISHES

SILVIO MONDINO STUDIO INTENTION IS TO DELIVER PRODUCTS THAT REFLECT OUR COMMITMENT TO GREAT DESIGN, MATERIAL INTEGRITY, AND HIGH CRAFTSMANSHIP.

WE PUT THE UTMOST CARE INTO MAKING EACH OF OUR PRODUCTS.

ALL OF OUR FINISHES ARE HAND-APPLIED, DEPENDING ON THE FINISH OR THE CLIENT'S NEEDS, THE BRASS CAN BE SEALED TO NOT CHANGE IN APPEARANCE OR UNSEALED TO PATINA BEAUTIFULLY OVER TIME.

AS A GENERAL RULE, WE RECOMMEND DUST GENTLY WITH A DUSTER OR SOFT RAG. PLEASE REFRAIN FROM USING ANY LIQUID OR CHEMICAL CLEANING SOLUTIONS AS THEY WILL AFFECT THE FINISH.

1 - UNLACQUERED:
THE FINISH IS "LIVE" AND CAN PATINA OVER TIME.

2 - LACQUERED:
THE FINISH IS HAND SEALED WITH A TINY LAYER OF TRANSPARENT LACQUER AND WILL NOT CHANGE OR PATINA OVER TIME.

3 - WAXED:
FINISH IS HAND SEALED WITH A TINY LAYER OF WAX, PROTECTING FROM PATINA OVER TIME, GIVING A SMOOTH TEXTURE TO THE SURFACES.

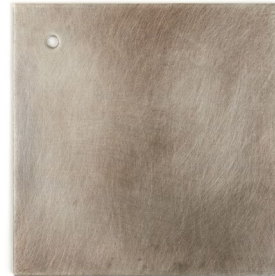

TARNISHED SILVER [3]



AGED BRASS [3]



DARKENED BRASS [2]



BLACKENED BRASS [3]



POLISHED BRASS [1]



BRUSHED NICKEL [1]



SATIN SILVER [2]



SATIN COPPER [2]



BRUSHED BRASS [2]

GLASS

SILVIO MONDINO STUDIO GLASSES ARE HAND-BLOWN BY ITALIAN ARTISANS.

SMALL DIFFERENCES IN SIZE OR SHAPE AS WELL AS MINOR IRREGULARITIES REVEAL THE CRAFTSMANSHIP AND UNDERLINE THE UNIQUENESS OF THE NON-INDUSTRIAL PROCESS.

CLEANING TIPS

AS A GENERAL RULE, MAKE SURE THE FIXTURE IS NOT ILLUMINATED OR WARM BEFORE CLEANING.

“AL LUSTRO” COLORS: SHOULD BE CLEANED WITH A SOFT, LINT-FREE, OR MICROFIBER CLOTH. PLEASE REFRAIN FROM USING LIQUID OR CHEMICAL CLEANING SOLUTIONS.

STARDUST WHITE: SHOULD BE CLEANED WITH A DUSTER OR SOFT RAG.

PLEASE REFRAIN FROM RUBBING AND DO NOT USE OILY SUBSTANCES.

GREASE STAINS CAN BE REMOVED USING ALCOHOL OR CITRIC ACID DISSOLVED IN DISTILLED WATER .



CLEAR



STARDUST WHITE



LEMON



FUMÉ



TOPAZ



TANGERINE



ROSE



BLUE

MATERIALS

01 - DARK HORN

02 - MONGOY WOOD

03 - CLASSIC GLOSSY MARQUINA MARBLE

04 - SATIN MARQUINA MARBLE

05 - BRAIDED CALFSKIN ROPE

06 - PALE BLOND HORSEHAIR

07 - DARK BROWN HORSEHAIR



01



02



03



04



05



06



07