

SPIRIT LAKE COLLECTION

LAMP 258H - 11"

Lamp 258H seamlessly merges the realms of tradition and modernity, embodying a pendant light that has the power to elevate any space. Meticulously constructed from the finest Western Red Cedar, Lamp 258H exudes exceptional craftsmanship, guaranteeing a touch of sophistication to your interior. Its creates a mesmerizing interplay of light, casting a captivating ambient glow in the area beneath the pendant.

DETAILS	
MATERIAL:	Western Red Cedar
TEXTURE:	Bandsawn, Smooth
FINISH:	Unfinished, Natural Oil

OVERALL DIMENSIONS	
WIDTH:	5-1/2"
WIDTH WITH TOP:	6"
DEPTH:	6"
HEIGHT:	11"
HEIGHT WITH TOP:	12"
WEIGHT:	3 lbs.

LIGHTING	
LIGHT SOURCE:	LED A19 Light Bulb
WATTAGE:	9W
VOLTAGE:	120V
COLOR TEMP:	2700k
LUMENS:	800
INCANDESCENT EQUIVALENCY:	60W
DIMMABLE:	Yes

INSTALLATION	
MOUNTING:	Ceiling Mounted
ELECTRIC WIRE LENGTH:	7'

SHIPPING	
BOX LENGTH:	10"
BOX WIDTH:	10"
BOX HEIGHT:	14"
BOX WEIGHT:	4 lbs.

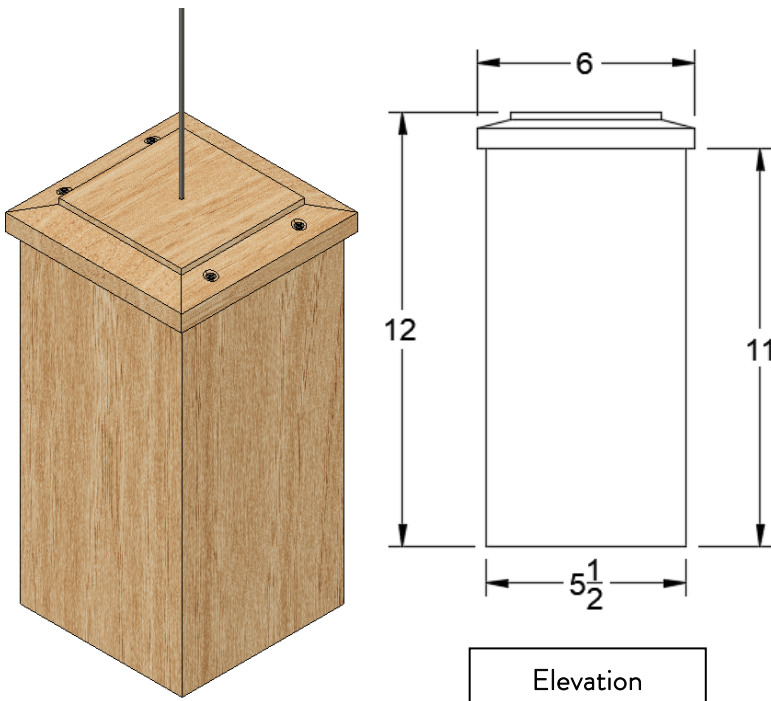

PRODUCT DETAILS:

- The solid side light acts as a downward facing spotlight casting light in only one direction.
- Available with eased or drawknife corner detail.
- Pending UL certification.
- Suitable for use in damp environments without the top cap and wet environments with the top cap.
- Bandsawn finish lamps are sawn to dimension by bandsaw which leaves a textured finish. Great for customers who want a classic look.
- Smooth finish lamps are sanded to a consistent texture, very smooth to the touch. Great for customers who want a near perfect finish.
- Dark Sky compliant with a top cap.