

Technical Data Sheet 2023

General jewelry casting resin

X-cast resin

Ultra cast resin

High wax plus resin

Jewelry mold resin

Printing Setting

Model No.	Layer height (mm)	Bottom exposure time(s)	Layer exposure time(s)	Bottom Lift Distance (mm)	Lifting Distance (mm)	Bottom Lift Speed (mm/min)	Lifting Speed (mm/min)	Retract Speed (mm/min)	Rest time after retract
General jewelry casting resin	0.05	40-50	8-12	6	6	60	80	150	2--3
High wax plus resin			8-10						
X-cast resin			8-12						
Ultra cast resin									
Jewelry mold resin		20-30	3-6						

Above settings are tested on ELEGOO MARS 3 (6.6" monochrome LCD screen, light intensity 3500~4500 μ w/cm²), they should be adjusted according to different 3d printers and printing model structure, most settings can be keep as the printers' default firstly.

1. Bottom layer count = Bottom layer thickness/ Layer height+1, e.g. Bottom height 0.4mm, layer height 50um, the bottom layer count= 0.4mm/0.05mm+1=9 layers.
2. The exposure time should be adjusted according to printer light energy, layer thickness and model structure. If the layer height less than 0.05mm, we suggest the exposure time of each layer will be deducted about 20-25%.
3. If light power of printer is getting weak and cause failure, don't forget to add exposure time.
4. When printing with ordinary FEP/NFEP film, the recommended lifting distance as below:
 Less than 7" screen size, lifting distance: 6mm; 7-10" screen size, lifting distance: 8-10mm
 10.1" screen size, lifting distance: 11mm; 13.3" screen size, lifting distance: 14mm
 15" screen size, lifting distance: 15mm
 When printing with fast printing film, lifting distance can be decrease 30-50%.
 e.g. lifting speed was 80 (mm/min) at regular film, you can adjust to 40-60(mm/min) while using fast printing film.

Technical Specification

UPIC Series & X-cast Resin Jewelry Casting Resin

	UPIC Series (General jewelry casting resin)	EC Series (X-cast resin)	Test Standard
Tensile strength (MPa):	20.88 ±10%	3.44 ±10%	ASTM D638
Tensile modulus (MPa):	152.8 ±10%	23.72 ±10%	ASTM D638
Elongation at yield point(%):	47.34 ±10%	8.76 ±10%	ASTM D638
Flexural modulus (MPa):	333.68 ±10%	220.46 ±10%	ASTM D790
Flexural strength (MPa):	13.75 ±10%	2.89 ±10%	ASTM D790
Notched impact strength (J/m):	117.72 ±10%	47 ±10%	ASTM D256
Maximum pulling force (N):	868.86 ±10%	143.17 ±10%	ASTM D638
Maximum force point of deformation (mm):	18.73 ±10%	8.50 ±10%	ASTM D638
Elongation at break (%):	32.96 ±10%	15.06 ±10%	ASTM D638
Hardness (Shore D):	58-68	43-45	ASTM D2240
Viscosity (MPa.S):	70-180	170-270	GB/T 4472
Density (g/cm³):	1.05-1.25	1.05-1.25	GB/T 22235

Ultra Cast Resin & High wax plus resin & Jewelry Mold Resin

	CWIC-10B (Ultra cast resin)	EWIC-3000 (High wax plus resin)	HTC-29A (Jewelry Mold Resin)	Test Standard
Tensile strength (MPa):	5.82 ±10%	21.02 ±10%	27.3 ±10%	ASTM D638
Tensile modulus (MPa):	46.73 ±10%	209.35 ±10%	316.6 ±10%	ASTM D638
Elongation at yield point(%):	8.80 ±10%	7.69 ±10%	5.3 ±10%	ASTM D638
Flexural modulus (MPa):	161.15 ±10%	425.80 ±10%	773.8 ±10%	ASTM D790
Flexural strength (MPa):	4.34 ±10%	16.50 ±10%	37.2 ±10%	ASTM D790
Notched impact strength (J/m):	37.5 ±10%	86.7 ±10%	76 ±10%	ASTM D256
Maximum pulling force (N):	242.22 ±10%	874.75 ±10%	1135.61 ±10%	ASTM D638
Maximum force point of deformation (mm)	7.30 ±10%	12.02 ±10%	9.0 ±10%	ASTM D638
Elongation at break (%):	13.06 ±10%	21.25 ±10%	16.1 ±10%	ASTM D638
Hardness (Shore D):	50-60	60-70	80-88	ASTM D2240
Viscosity (MPa.S):	80-150	150-230	150-300	GB/T 4472
Density (g/cm³):	1.05-1.25	1.05-1.25	1.05-1.25	GB/T 22235

Introduction of Testing Machine & Testing Environment

Computer-controlled Servo Tensile Testing Machine

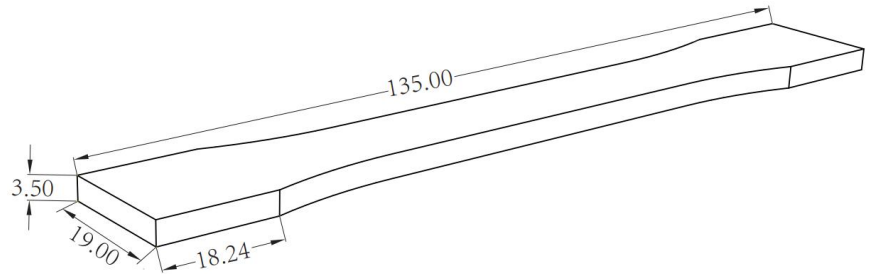
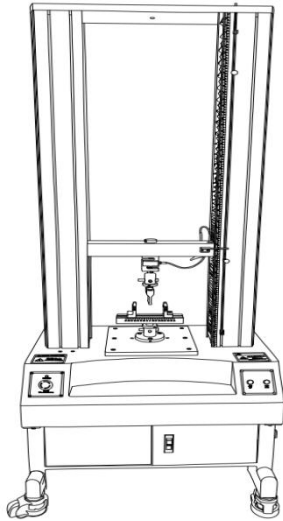

Tensile test specimen ASTM D638

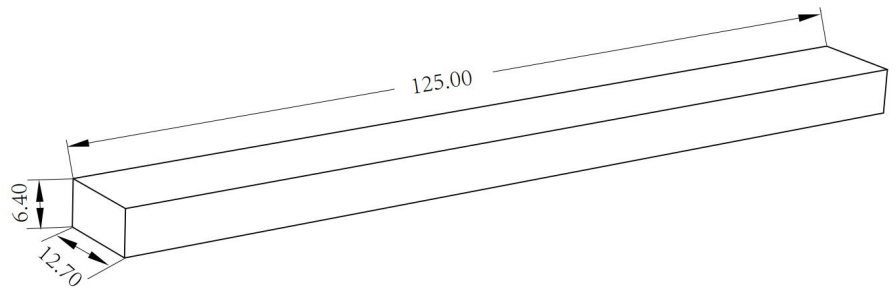

Flexural test specimen ASTM D790

Digital IZOD Impact Tester

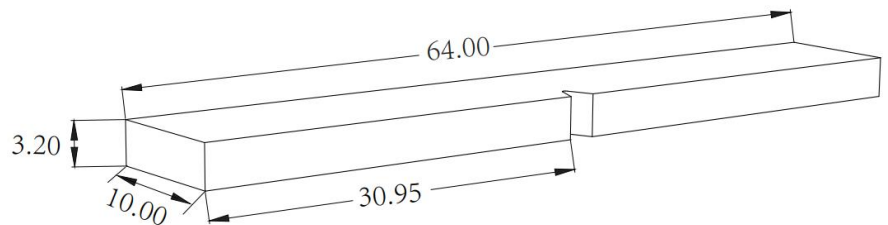
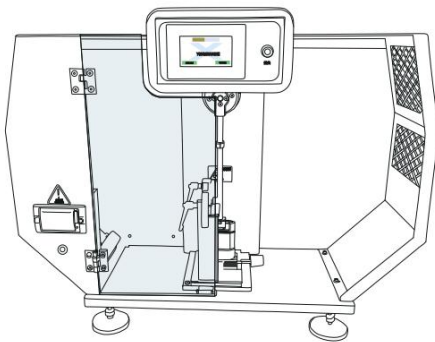

Impact test specimen ASTM D256

Testing Environment

Temperature: $23 \pm 2^\circ\text{C}$

Relative Humidity: $50\%RH \pm 5\%RH$

Standard for Testing Splines: ASTM

Post Curing Box: 405nm UV, $200\text{mw}/\text{cm}^2$

Put the test strip in water and post cured for 1 minute on both sides.

Cleaning Process and Post-curing Process of All Jewelry Castable Resin



1. Remove the printing platform from the printer.

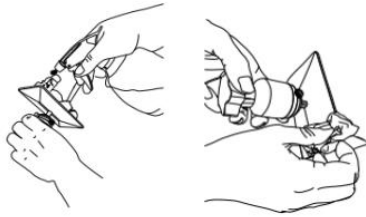

2. Spray Isopropanol (alcohol > 95%) to clean away residue resin that on the prints and wipe off the resin with tissue from the platform.

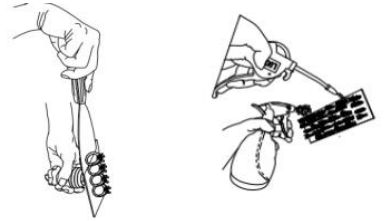

4. Carefully take off the prints from platform with scraper. Spray alcohol again then dry it with air gun, repeat a few times till there's no resin on surface.



5. Place the work piece into a container with alcohol, the alcohol should fully cover it.

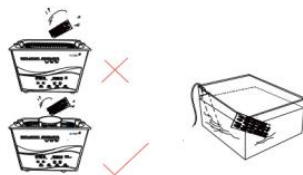

6. It is recommended to put the prints in a container with alcohol fully cover while using ultrasonic machine which is safer. If there is no ultrasonic cleaner, try to use an ultrasonic rod.
 Recommended post-curing time:
 General jewelry casting resin, 1-2 mintues
 X-cast resin/ High wax plus resin/ Ultra cast resin, 5 mintues.



7. Dry and clean the work piece immediately.

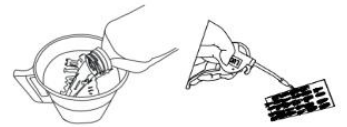

8. Prepare a container with fresh alcohol, put the prints in it and repeat the steps **6&7** if necessary. After thoroughly cleaning, take out the prints and dry immediately with an air gun or a blower.



9. Suggest to do post curing in water, curing time depends on the light power of the curing box and thickness of the prints.

(Normally recommended curing time: 30-60s, curing both sides).



10. Take prints out and dry.

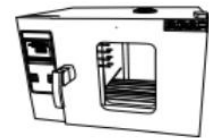

Notice: If here are white dots on prints, just ignore, do not affect casting result. Or you can blow it with hot wind till the white spots disappeared, or baked it in the oven at 160℃ for 10 minutes.

Introduction of Post-curing Ultra-Cast Resin Model from Yellow to White color :



9. After step **8**, prepare a container with fresh alcohol, soak in IPA for 30mins.



10. Take out the prints and dry immediately with an air gun or a blower.



11. Soak in 100℃ hot water, water level soak the prints completely with margin.



12. Post-curing in 500w(or above 500w) curing box for 30mins-40mins.



13. Take out the prints and dry it with hot wind.



14. The prints will be in white.

Notice:

The prints in yellow or white do not affect casting results.

Caution

1. Shake the resin well before use.
2. Wash hand and face thoroughly after handling.
3. Wear protective gloves / mask/protective clothing when using resin.
4. Contact eyes may cause irritation, immediately flush eyes with plenty of water for at least 15 minutes.
Seek medical advice immediately if necessary.
5. Waste water/waste shall be disposed of in accordance with local environmental regulations.

Storage

1. Please seal the product and store it in a dry, well-ventilated room with no corrosive gas.
2. Stored at 25~30°C environment.
3. Keep away from heat source, keep away from moisture and avoid sun exposure.
4. Shelf life 18 months.