

Technical Data Sheet 2023

Hi-Speed Standard Resin

Standard Pro Resin

10K Standard Plus Resin

10K Washable Resin

10K Nano Resin

M5 Series Resin

Plant Based Standard Resin

Plant Based ABS Like Resin

Printing Setting

Model No.	Layer height (mm)	Bottom exposure time(s)	Layer exposure time(s)	Bottom Lift Distance (mm)	Lifting Distance (mm)	Bottom Lift Speed (mm/min)	Lifting Speed (mm/min)	Retract Speed (mm/min)	Rest time after retract
10K Nano Resin	0.05	25-35	2.5--3.5 orange red resin : 3--4	6	6	60	80	150	2--3
M5 Series Resin									
10K Standard Plus Resin									
10K Washable Resin									
Plant Based Standard Resin			2.5--4.5						
Plant Based ABS Like Resin									
Standard Pro Resin									
Hi-Speed Standard Resin (Normal 3D Printer)			20-25						
Hi-Speed Standard Resin (Hi-Speed 3D Printer)	20-25	1.2--1.8							
Hi-Speed Standard Resin (Hi-Speed 3D Printer, ACF film)	0.1	20-25	1.8--2	3	3	1300	1300	1300	0.5

Above settings are tested on ELEGOO MARS 3 (6.6" monochrome LCD screen, light intensity 3500~4500μw/cm²), they should be adjusted according to different 3d printers and printing model structure, most settings can be keep as the printers' default firstly.

Hi-Speed Standard Resin tested on high speed printer Anycubic M5S (10.1inch, 12K, ACF film)

- Bottom layer count = Bottom layer thickness/ Layer height+1, e.g. Bottom height 0.4mm, layer height 50um, the bottom layer count= 0.4mm/0.05mm+1=9 layers.
- The exposure time should be adjusted according to printer light energy, layer thickness and model structure. If the layer height less than 0.05mm, we suggest the exposure time of each layer will be deducted about 0.5s.
- If light power of printer is getting weak and cause failure, don't forget to add exposure time.
- When printing with ordinary FEP/NFEP film, the recommended lifting distance as below:
 Less than 7" screen size, lifting distance: 6mm; 7-10" screen size, lifting distance: 8-10mm
 10.1" screen size, lifting distance: 11mm; 13.3" screen size, lifting distance: 14mm
 15" screen size, lifting distance: 15mm

While printing with fast printing film (ACF film), lifting distance can be decrease 30-50%.

e.g. lifting speed was 80 (mm/min) at regular film, you can adjust to 40-60(mm/min) when using fast printing film (ACF film).

Notice: shake the resin well before use.

Technical Specification

Hi-Speed Standard Resin & Standard Pro Resin & 10K Standard Plus Resin & 10K Washable Resin

	Hi-Speed Standard Resin FR-A	Standard Pro Resin	10K Standard Plus Resin	10K Washable Resin	Test Standard
Tensile strength (MPa):	42.77±10%	42.77±10%	37.88 ±10%	31.44 ±10%	ASTM D638
Tensile modulus (MPa):	518.35±10%	518.35±10%	615.49 ±10%	471.03 ±10%	ASTM D638
Elongation at yield point(%):	5.38±10%	6.38±10%	3.09 ±10%	6.32 ±10%	ASTM D638
Flexural modulus (MPa):	1284.19±10%	1284.19±10%	1699.7 ±10%	1091.45 ±10%	ASTM D790
Flexural strength (MPa):	47.48±10%	47.48±10%	57.91 ±10%	40.82 ±10%	ASTM D790
Notched impact strength (J/m):	101.04±10%	101.04±10%	72 ±10%	50 ±10%	ASTM D256
Maximum pulling force (N):	1779.51±10%	1779.51±10%	1575.93±10%	1308.20±10%	ASTM D638
Maximum force point of deformation (mm)	7.61±10%	7.61±10%	3.62 ±10%	4.33 ±10%	ASTM D638
Elongation at break (%):	9.26±10%	15.26±10%	6.41 ±10%	7.65 ±10%	ASTM D638
Hardness (Shore D):	80-86D	80-86D	80-88 D	80-85 D	ASTM D2240
Viscosity (MPa.S):	50-100	200-400	250-400	70-175	GB/T 4472
Density (g/cm ³):	1.05-1.25	1.05-1.25	1.05-1.25	1.05-1.25	GB/T 22235

10K Nano Resin & M5 Series Resin & Plant Based Standard Resin & Plant Based ABS Like Resin

	10K Nano Resin	M5 Series Resin	Plant Based Standard Resin	Plant-Base ABS-like Resin	Test Standard
Tensile strength (MPa):	37.9 ±10%	45.40±10%	32.43 ±10%	27.46 ±10%	ASTM D638
Tensile modulus (MPa):	508.12 ±10%	687.73±10%	424.97 ±10%	328.5 ±10%	ASTM D638
Elongation at yield point(%):	6.21 ±10%	6.09±10%	5.54 ±10%	5.57 ±10%	ASTM D638
Flexural modulus (MPa):	1188.91 ±10%	1570.52±10%	768.67 ±10%	531.27 ±10%	ASTM D790
Flexural strength (MPa):	41.4 ±10%	49.80±10%	29.82 ±10%	20.27 ±10%	ASTM D790
Notched impact strength (J/m):	46 ±10%	42±10%	40.03 ±10%	58 ±10%	ASTM D256
Maximum pulling force (N):	1576.91 ±10%	1888.76±10%	1349.40±10%	1142.47 ±10%	ASTM D638
Maximum force point of deformation (mm)	6.87 ±10%	4.33±10%	9.86 ±10%	12.33 ±10%	ASTM D638
Elongation at break (%):	12.15 ±10%	7.67±10%	17.48 ±10%	21.8 ±10%	ASTM D638
Hardness (Shore D):	82-86 D	84-88D	80-88 D	78-86 D	ASTM D2240
Viscosity (MPa.S):	150-300	200-400	200-450	200-400	GB/T 4472
Density (g/cm ³):	1.05-1.25	1.05-1.25	1.05-1.25	1.05-1.25	GB/T 22235

Introduction of Testing Machine & Testing Environment

Computer-controlled Servo Tensile Testing Machine

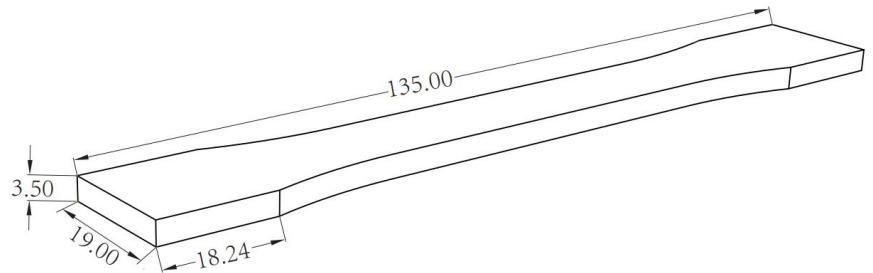
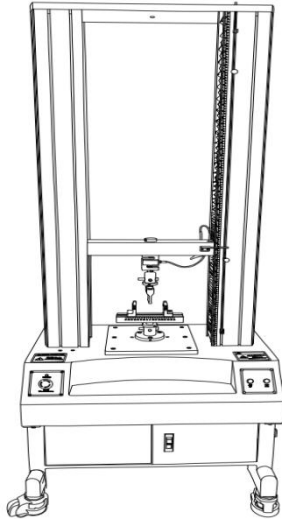

Tensile test specimen ASTM D638

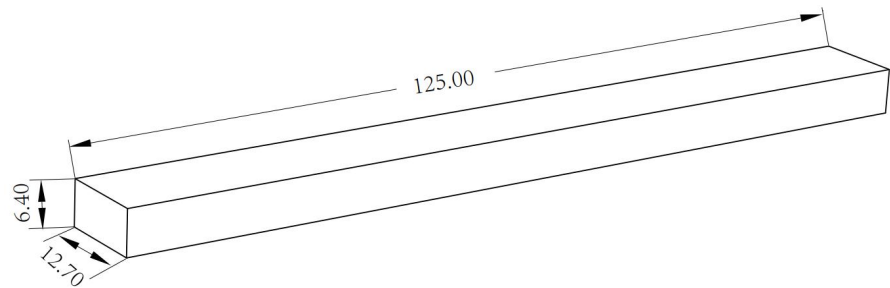

Flexural test specimen ASTM D790

Digital IZOD Impact Tester

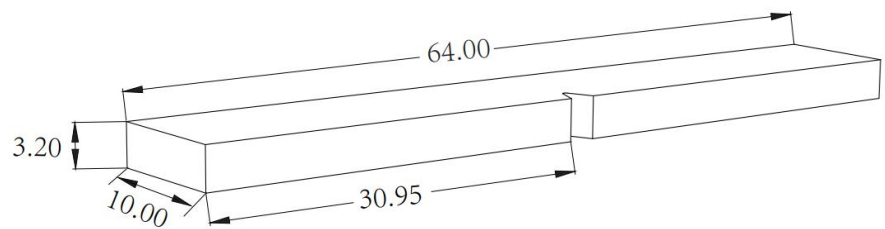
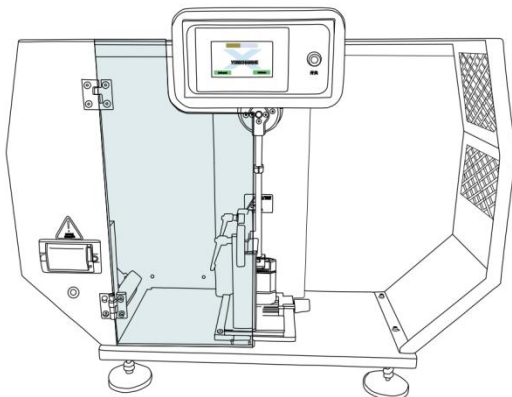

Impact test specimen ASTM D256

Testing Environment

Temperature: $23 \pm 2^{\circ}\text{C}$

Relative Humidity: $50\%RH \pm 5\%RH$

Standard For Testing Splines: ASTM

Post Curing Box: 405nm UV, $200\text{mw}/\text{cm}^2$

Put the test strip in water and post cured for 1 minute on both sides.

Cleaning and Post-curing

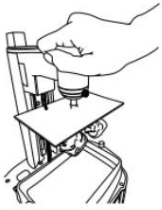

1. Take off the printing platform from the printer.

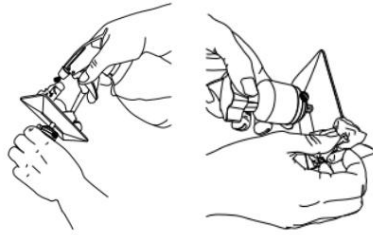

2. Spray isopropanol (alcohol > 95%) to clean away residue resin on the prints, wipe off the resin with tissue on the platform.

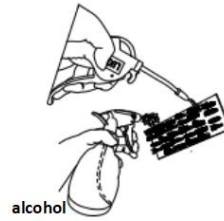

3. Spray alcohol again, dry it with air gun, repeat a few times till there's no resin on surface.



4. Carefully take off the prints from platform with scraper.

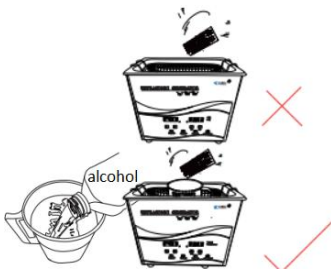

5. Soak the prints in alcohol in container, clean for 1-2min by ultrasonic machine.

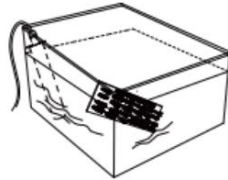

If no ultrasonic cleaner, try to use an ultrasonic rod to clean for 2-3min.

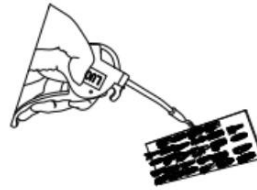

6. Take out the prints and dry immediately with an air gun or a blower.



7. Suggest post curing in water, curing time 30-60s depends on the light power of the curing box (curing both sides).
Repeat step 6.

Notice: For water washable resin, just cleaning with water by ultrasonic machine, don't forget to dry them in and out after post curing.

Caution

1. Wash hand and face thoroughly after handling.
2. Wear protective gloves / mask/protective clothing when using resin.
3. Contact eyes may cause irritation, immediately flush eyes with plenty of water for at least 15 minutes.
 Seek medical advice immediately if necessary.
4. Waste water/waste shall be disposed of in accordance with local environmental regulations.

Storage

1. Please seal the product and store it in a dry, well-ventilated room with no corrosive gas.
2. Stored at 25~30°C environment.
3. Keep away from heat source, keep away from moisture and avoid sun exposure.
4. Shelf life 24 months.