



Find out  
MORE

**Assemble me.  
Explore the iconic rocket!**



  
**UGEAR'S**

Mechanical models

## **NASA Saturn V NASA Сатурн-5**

**FRA** Saturn V de la NASA **DEU** NASA Saturn V  
**SPA** Saturno V de la NASA **ITA** Saturn V della NASA  
**JPN** NASA サターンV  
**CHI** NASA土星5号 **POR** Saturno V da NASA  
**POL** NASA Saturn V **KOR** 나사 새턴 V

### **Assembly instructions Інструкція зі складання**

**FRA** Notice d'assemblage. **DEU** Aufbauanleitung.  
**SPA** Instrucciones de montaje. **ITA** Istruzioni di montaggio.  
**JPN** 組み立て説明書 **CHI** 装配说明书  
**POR** Instruções de montagem. **POL** Instrukcja montażu.  
**KOR** 조립 설명서.

**ENG**

Assembly instructions:  
Remove model parts from the hanger board as illustrated below. Careful not to break parts. If a part does not remove easily, carefully cut it out with a knife. This model is intended for self-assembly without glue. If you have difficulty installing the axles, try waxing them with a regular candle. All moving parts can also be waxed during assembly to reduce friction when operating the model.

**CHI**

装配说明  
将模型部件按插图所示，从胶合板取下。小心不要损坏件。如果取下时候有难度，请用小刀小心的切割连接点。这个产品不需要胶水粘接。如果安装转轴的时候有难度，请用普通的蜡加以润滑。所有的转动部分也需要打蜡润滑。

**UKR**

Інструкція зі складання:  
Витягніть з дошки позначені на схемі деталі. Намагайтеся їх не зламати. Якщо деталь не виймається, надсічіть перемички ножом. Конструкція збирається без клею. У разі виникнення труднощів з протягуванням вісі в отвір, потріть деталь об звичайну свічку. Також можна змастити свічкою всі деталі механізму, що рухаються, щоб зменшити тертя при обертанні.

**POR**

Instruções de montagem:  
Remova as peças do modelo da placa de suporte conforme ilustrado abaixo com cuidado para não quebrá-las. Se uma peça não puder ser removida facilmente, corte-a cuidadosamente com uma faca. Este modelo foi feito para ser montado de forma prática, sem precisar usar cola. Se você tiver dificuldade em instalar os eixos, tente passar um pouco de cera, como por exemplo, a de uma vela comum. Todas as peças móveis também podem ser enceradas durante a montagem para reduzir o atrito ao operar o modelo.

**FRA**

Notice d'assemblage:  
Faites sortir de la planche les pièces comme indiquées sur le schéma. Tâchez de ne pas les casser. Si la pièce ne sort pas, incisez les collages/fixations avec un couteau. La construction est à assembler sans colle. Si il est difficile d'introduire l'axe en bois dans l'orifice, frottez au préalable l'axe ou les pièces contre une bougie. Pour améliorer le glissement, traitez les pièces de frottement mobiles du mécanisme avec une bougie au cours d'assemblage.

**POL**

Instrukcja montażu:  
Delikatnie wyciągaj z deseczki wskazane w schemacie detale, starając się nie połamać elementów. Jeśli detal nie poddaje się, podetnij wiązadła nożem. Konstrukcja składa się bez kleju. Jeśli napotkasz trudności z instalacją drewnianej osi w otwór, potrzyj na początku oś lub detale o woskową świecę. Dla lepszego poślizgu polecano smarowanie ruchomych części mechanizmu zwykłą świecą podczas montażu.

**DEU**

Aufbauanleitung:  
Bitte die in der Zeichnung angegebenen Teile aus der Platte herausnehmen. Versuchen Sie bitte diese nicht zu brechen. Wenn sich ein Teil nicht herausnehmen lässt, schneiden Sie die Stege mit dem Messer leicht an. Das Modell wird ohne Klebstoffe zusammengesetzt. Lässt sich eine Achse nur schwer in eine Öffnung einführen, reiben Sie diese mit einer Kerze etwas ein. Für besseres Gleiten schmieren Sie alle beweglichen Teile mit einer Kerze.

**KOR**

조립 설명:  
부품이 손상되지 않도록 주의하여 보드에서 떼어냅니다. 만약 부품이 잘 떨어지지 않으면 연결 부분을 칼로 절단 한 후 떼어내면 쉽게 떼어 낼 수 있습니다. 본 제품은 접착제가 없이 조립이 가능하도록 설계되어 있습니다. 만약 축이 잘 끼워지지 않는 경우 양초를 축에 바른 후 끼워 보세요. 모든 구동 부위는 제품 구동 시 원활한 작동이 가능하도록 조립 과정에서 윤활제(양초)양초를 발라 주세요.

**SPA**

Instrucciones de montaje:  
Saque de la tabla las piezas marcadas en el esquema. Trate de no romperlas. Si una pieza no se saca, haga una incisión. La construcción va sin pegamento. Si tiene dificultades con la instalación del eje de madera en un agujero, frote primero el eje o las piezas contra una vela. Para un mejor deslizamiento, lubrique durante el montaje las piezas móviles del mecanismo con una vela común.

**ITA**

Istruzioni di montaggio:  
Estrarre dal telaio i particolari indicati nello schema. Fare attenzione a non romperli. Se un particolare non si stacca, tagliare delicatamente gli elementi di collegamento con un coltello. L'assieme viene realizzato senza colla. In caso di difficoltà nell'inserimento di un perno in legno, è necessario sfregare il perno o il particolare con un po' di cera. Per uno scorrimento migliore incerare le parti mobili del meccanismo durante l'assemblaggio.

**JPN**

組み立て説明書:  
部品に傷をつけないように注意しながらボードから外してください。部品が外れにくい場合は連結部分をカッターで切ってから外すと外しやすいです。本製品は、接着剤がなくても組み立てができるように設計されています。もしアクスル(駆動部)が、歯車の動きがにぶい場合は、口ウソクをアクスルに塗ってください。全ての駆動部分は製品を動かす時、滑らかに動くように潤滑剤である口ウソクを塗りながら組み立てます。

**ENG** Warning! **UKR** Увага! **FRA** Attention! **DEU** Achtung! **SPA** Precaución!  
**ITA** Attenzione! **JPN** 注意! **CHI** 注意! **POR** Atenção! **POL** Uwaga! **KOR** 주의!



**ENG** Do not use a lighted candle! **UKR** Не підпалювати!  
**FRA** Ne pas brûler! **DEU** Nicht anzünden!  
**SPA** ¡No encender! **ITA** Non dare fuoco!  
**JPN** 火のついた口ウソクの使用はお止めください。  
**CHI** 请勿点燃，请勿靠近火源！ **POR** Não use uma vela acesa!  
**POL** Nie podpalać! **KOR** 불이 붙은 초를 이용하지 마세요!

**ENG** Customer support **UKR** Служба підтримки **FRA** Service client **DEU** Kundendienst  
**SPA** Servicio al cliente **ITA** Servizio di supporto **JPN** お客様窓口 **CHI** 客户支持  
**POR** Atendimento ao cliente **POL** Wsparcie klienta **KOR** 고객센터

customerservice@ugearsmodels.com



**ENG** Pay attention. Check position of the part. **UKR** Зверніть увагу. Перевірте розташування елемента. **FRA** Faites attention. Vérifiez la disposition de l'élément. **DEU** Bitte Beachten. Prüfen Sie die Einbaulage des Elementes. **SPA** Atención. Compruebe la situación del elemento. **ITA** Prestare attenzione. Controllare la posizione del componente. **JPN** 方向及び位置に注意して組み立ててください。 **CHI** 注意! 检查部件方向和位置 **POR** Preste atenção. **POL** Zwróć uwagę. Sprawdź lokalizację elementu. **KOR** 방향 또는 위치에 주의해서 조립해 주세요.



**ENG** Sand to remove burrs. **UKR** Видалить задирки. **FRA** Eliminez les bavures. **DEU** Grat entfernen. **SPA** Quite las rebabas. **ITA** Togliere le bave. **JPN** バリ取りのサンドペーパー **CHI** 磨掉毛刺 **POR** Lixe para remover as rebarbas. **POL** Usuń zadziory. **KOR** 거친 부분을 다듬어 주세요.



**ENG** Wax the part with a regular candle (rub with a candle). **UKR** Змастити деталь звичайною свічкою (потріть об свічку). **FRA** Lubrifiez la pièce avec une bougie ordinaire (frottez contre la bougie). **DEU** Reiben Sie das Teil mit einer einfachen Kerze etwas ein. **SPA** Engrase la pieza con una vela común (frote con una vela). **ITA** Incerare il componente (Sfregare con la cera). **JPN** された部分に潤滑剤としてロウソクを塗ってください。 **CHI** 用普通蜡烛涂抹润滑部件 **POR** Encere a peça com uma vela comum (esfregue com uma vela). **POL** Przesmaruj zwykłą świecą. **KOR** 표시된 부분에 윤활을 위해 초를 칠해 주세요.



**ENG** The part should be easily rotated (moved). **UKR** Деталь повинна легко крутитися (рухатися). **FRA** La pièce doit tourner (se déplacer) aisément. **DEU** Der Teil soll leicht gedreht (bewegt) werden. **SPA** La pieza debe ser fácil de girar (mover). **ITA** Il componente deve girare (muoversi) facilmente. **JPN** 部品はしっかりと動かなければなりません。 **CHI** 此部件必须容易的旋转 (移动) **POL** Element powinien łatwo się kręcić (poruszać się). **POR** A peça deve ser facilmente girada (movida). **KOR** 활하게 움직일 수 있어야합니다.



**ENG** Do not fully press the outer parts (structural frame) together until checking for fit and alignment of internal parts. **UKR** Деякий час не притискайте сильно деталі (рамки конструкції). **FRA** Ne pas forcer sur les pièces (cadre de la construction). **DEU** Drücken Sie die Teile (die Rahmen der Konstruktion) momentan nicht stark. **SPA** No presione temporalmente con fuerza las piezas (marco de la estructura). **ITA** Non stringere provvisoriamente i componenti con forza (base della costruzione). **JPN** 内部部品がしっかりと組み立てられる前に外部部品は強く押しながら固定してはいけません。 **CHI** 在检查内部零件的配合和对准之前, 请暂时不要将外部零件 (结构框架) 完全压在一起。 **POR** Não pressione totalmente as peças externas (estruturais) até verificar que as peças externas estão bem encaixadas e alinhadas. **POL** Tymczasowo nie dociskaj elementów (ramy konstrukcji). **KOR** 아직은 외부의 틀을 완전히 눌러서 고정하면 안됩니다. 다른 부품을 먼저 끼우세요.



**ENG** Press the parts as far as they will go. **UKR** Притисніть деталі до упору. **FRA** Pressez les pièces à fond. **DEU** Drücken Sie die Teile bis zum Anschlag. **SPA** Pulse para detener las piezas. **ITA** Stingere bene i componenti. **JPN** 部品をできる限り押してください。 **CHI** 用力紧密结合部件 **POR** Pressione as peças o máximo possível. **POL** Przyciśnij element, aż do oporu. **KOR** 부품을 양쪽에서 눌러서 고정해 주세요.

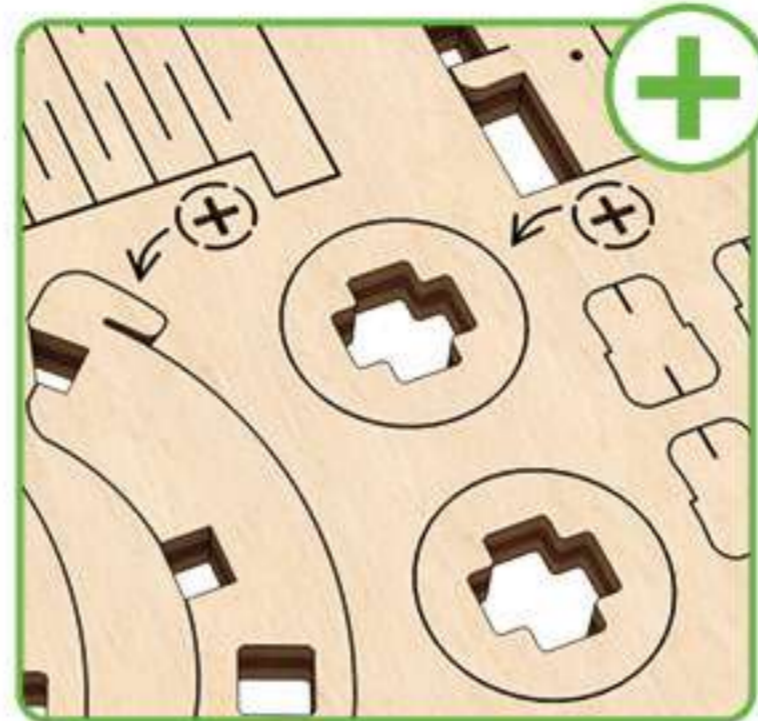

**ENG** Spare parts.  
**UKR** Запасні деталі.  
**FRA** Pièces de rechange.  
**DEU** Ersatzteile.  
**SPA** Piezas de repuesto.  
**ITA** Pezzi di ricambio.  
**JPN** 予備部品。  
**CHI** 备用件。  
**POR** Peças de reposição.  
**POL** Części zamienne.  
**KOR** 여유 부품입니다.

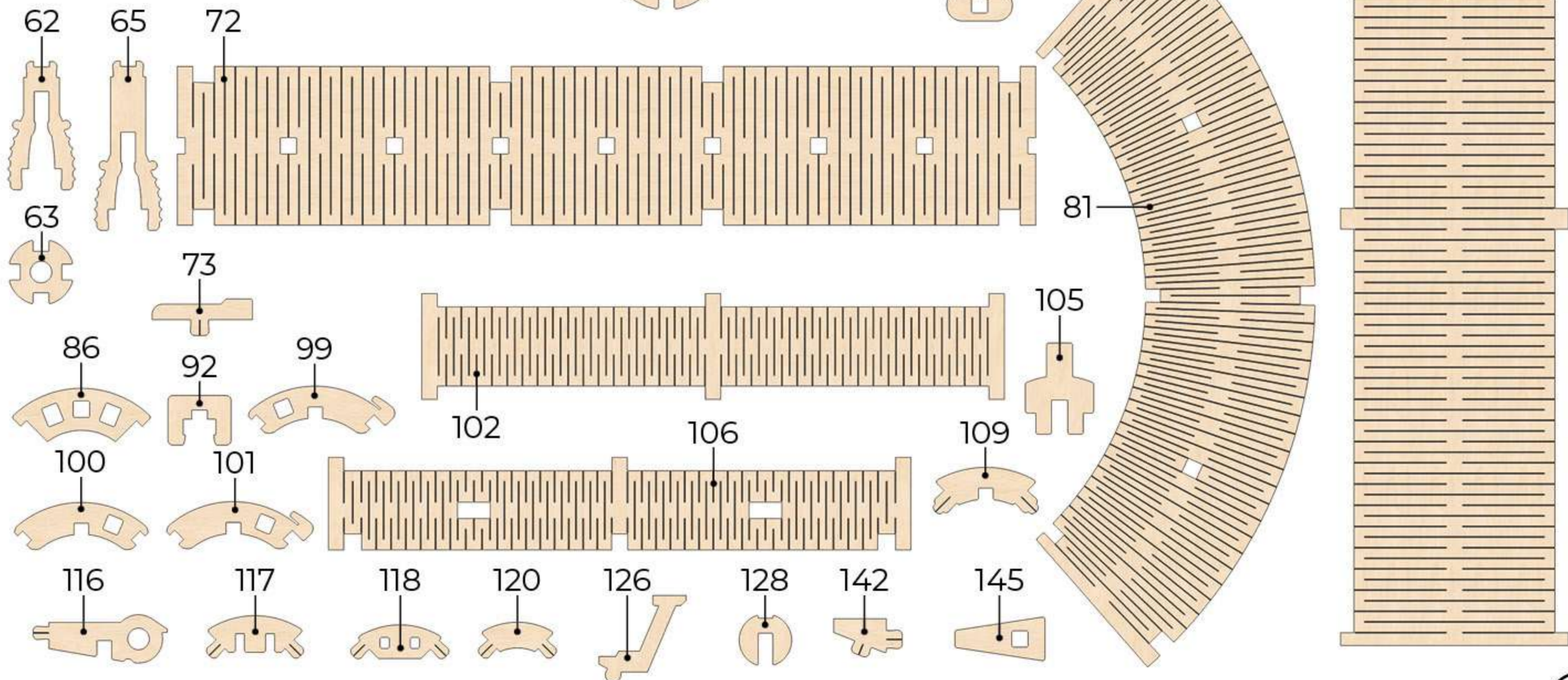
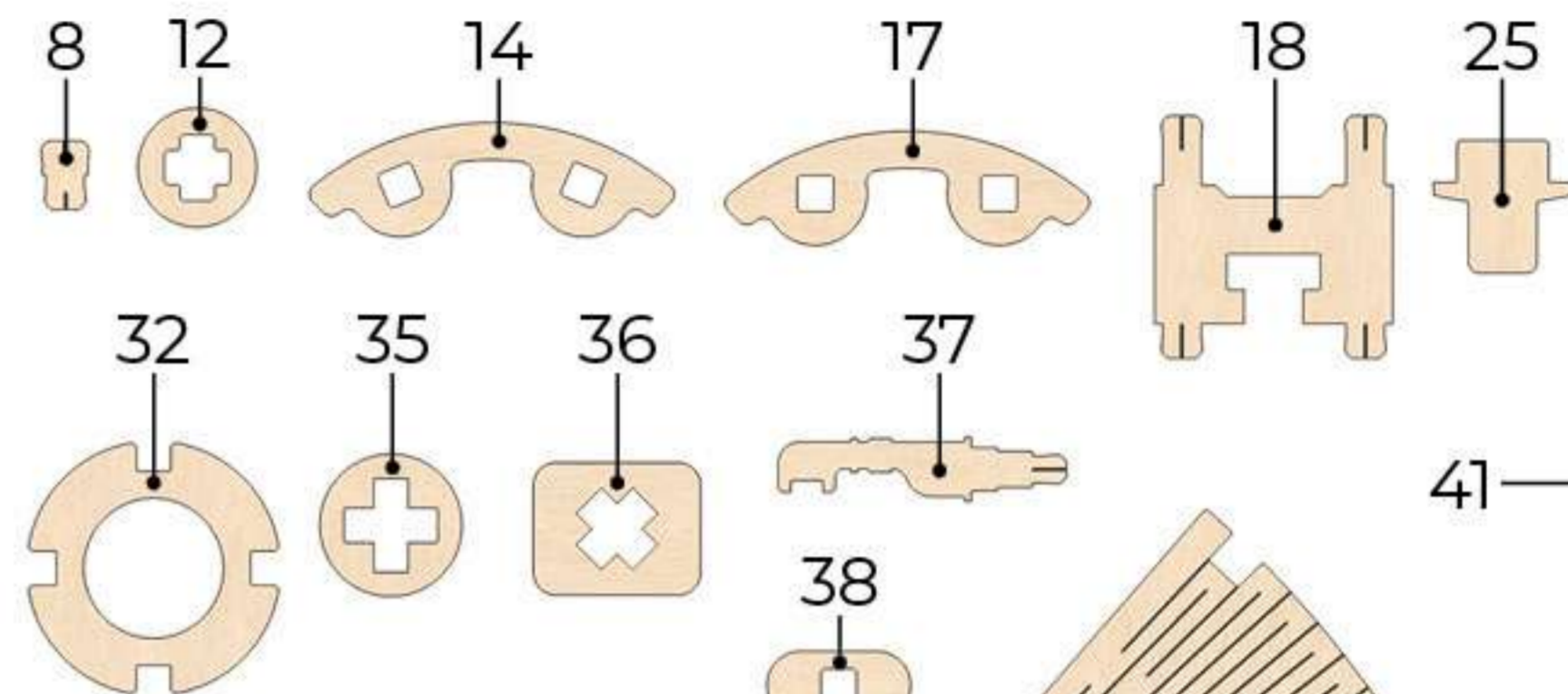

1

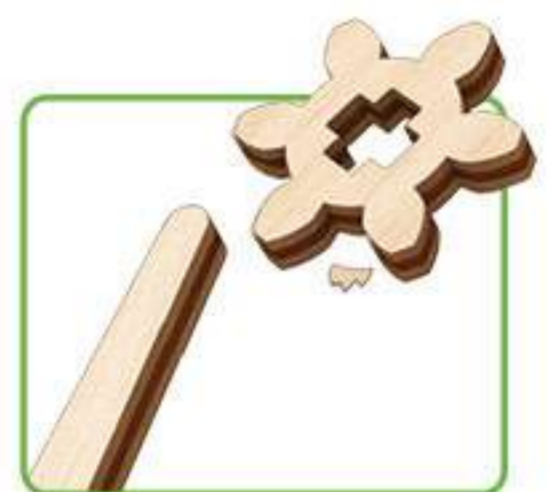
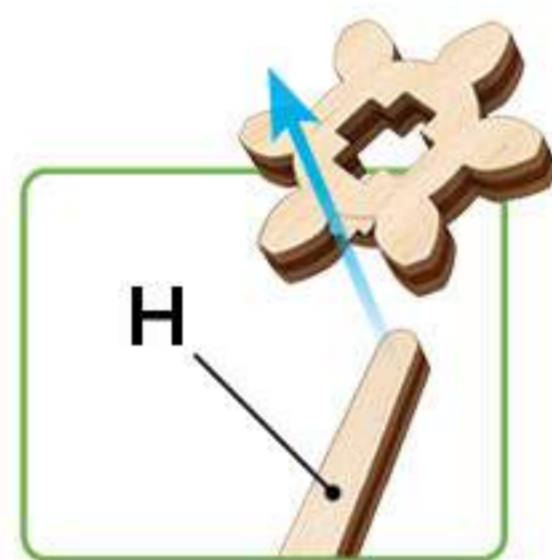
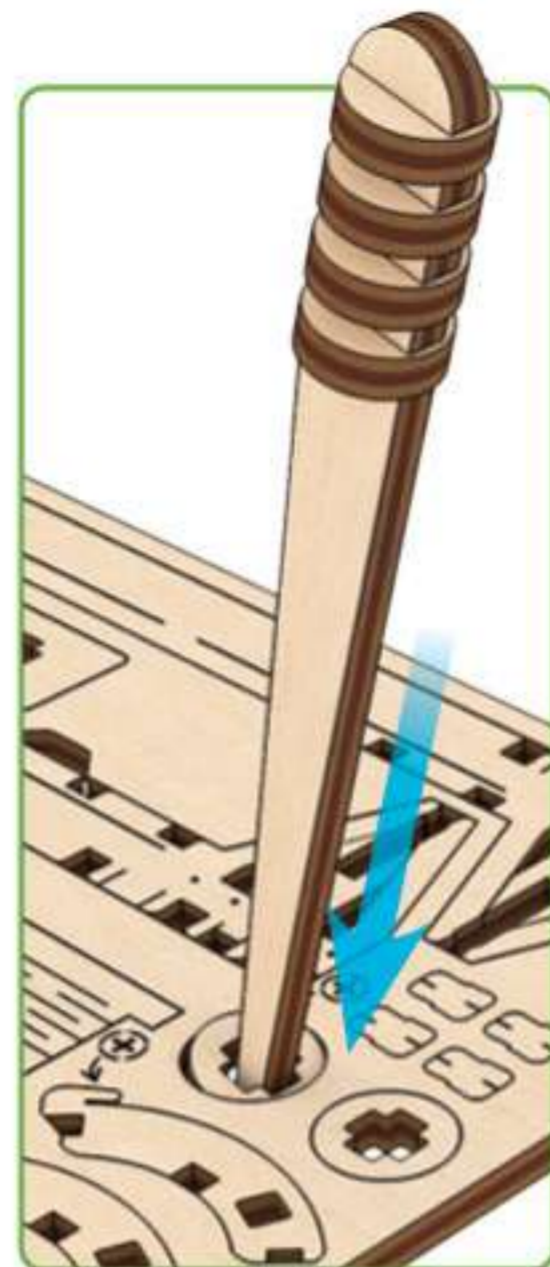
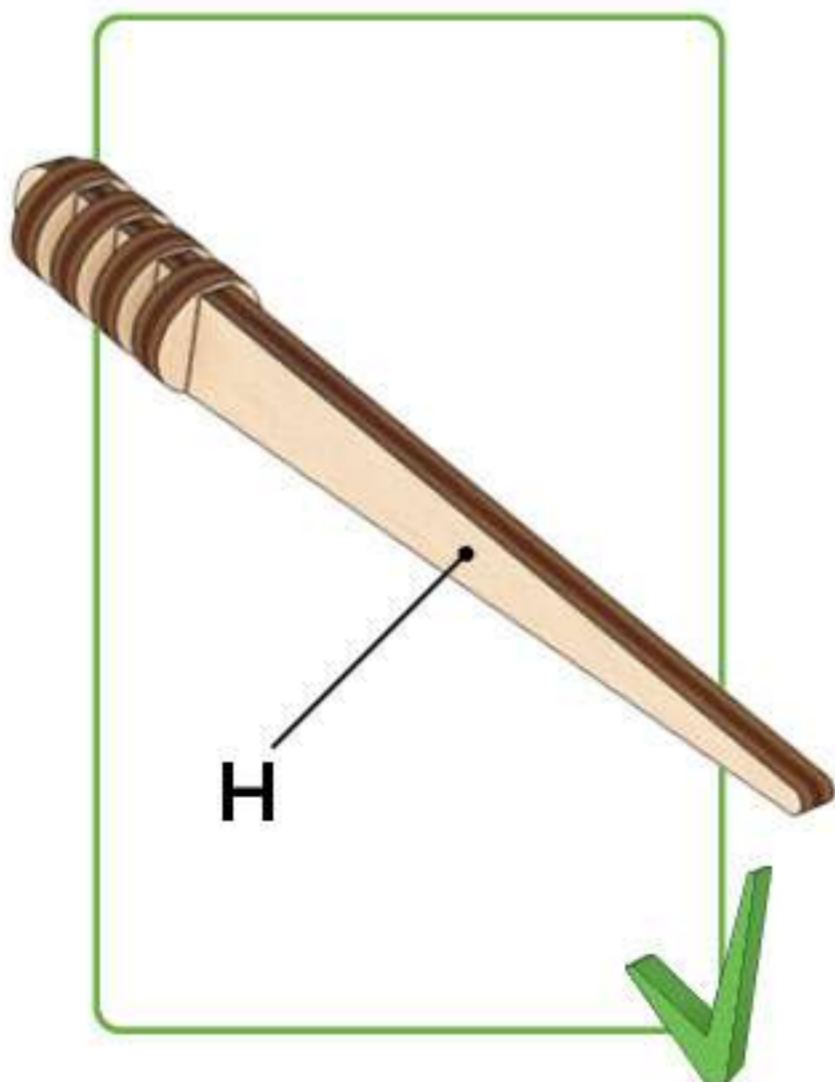
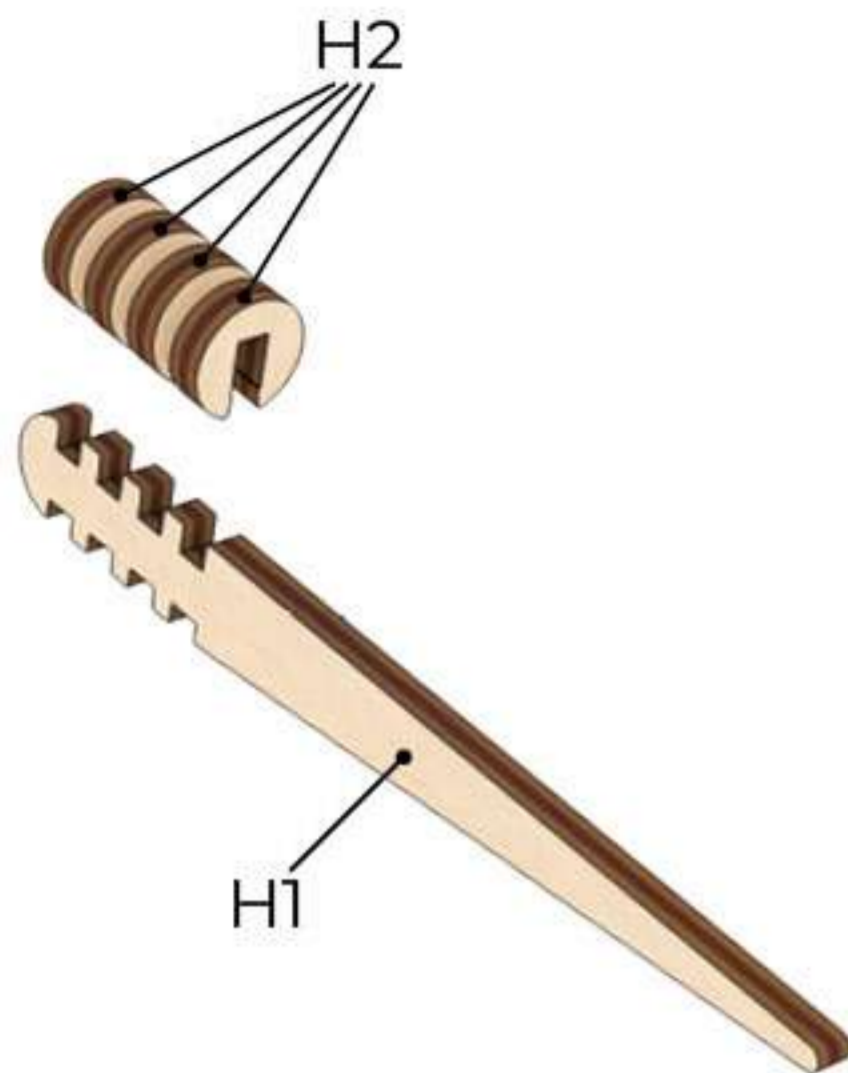
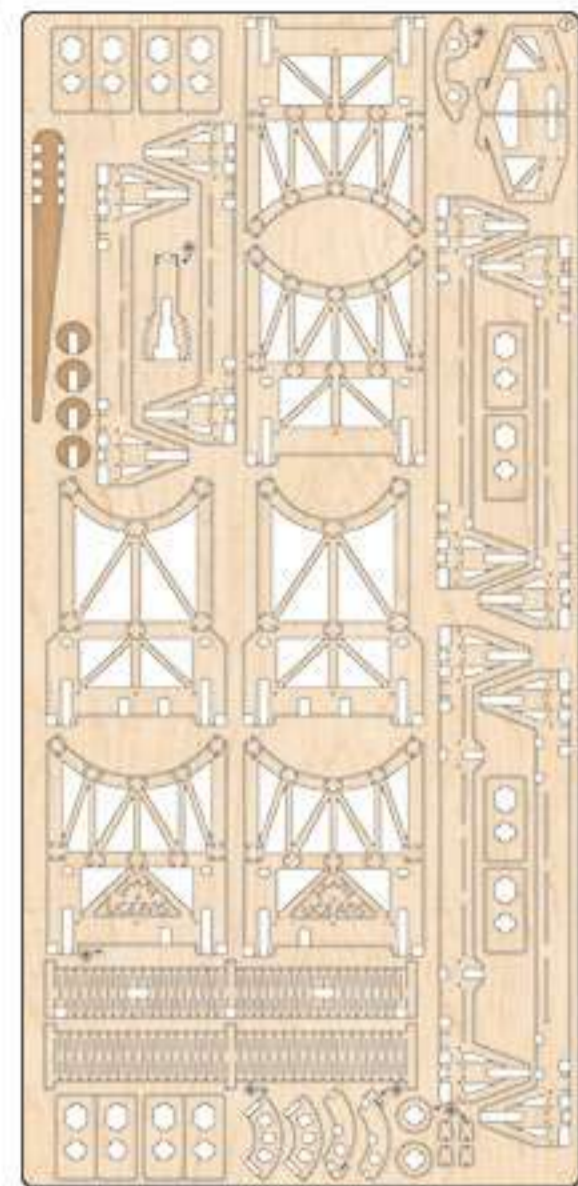

**ENG** This is not a structural component; it is a tool for measurement and assembly.

**UKR** Це не деталь конструкції, а допоміжний інструмент для складання або вимірювання відстаней.

**FRA** Cette pièce ne fait pas partie de la construction mais constitue un outil annexe pour l'assemblage ou la mesure des distances.

**DEU** Es ist kein Teil der Konstruktion, sondern ein Hilfselement für den Zusammenbau oder für das Messen der Abstände.

**SPA** No es una pieza de la construcción sino un instrumento auxiliar para montar o para medir distancias.

**ITA** Non è un componente del modello, ma un'attrezzatura aggiuntiva per il montaggio o il rilievo delle quote.

**JPN** この部品は完成時の部品ではなく、組み立てをサポートしたり測定する道具です。

**CHI** 这不是装配零部件，是一种测量及安装辅助工具。

**POR** Este não é um componente estrutural, é uma ferramenta para medição e montagem.

**POL** To nie detal konstrukcji, a pomocnicze narzędzie dla montażu i wymiaru odległości.

**KOR** 이 부품은 조립을 위한 부품이 아니고 조립을 돕거나 측정을 위한 도구입니다.

**ENG** Clean the burrs on the parts using the universal "Helper" (H) instrument.

**UKR** Очистіть задирки на деталях за допомогою універсального інструменту «Helper» (H).

**FRA** Nettoyez les bavures sur les pièces à l'aide de l'outil universel « Helper » (H).

**DEU** Entfernen Sie die Grate an den Teilen mit dem "Helper" Universalwerkzeug (H).

**SPA** Limpie las rebabas de las piezas utilizando la herramienta universal "Helper" (H).

**ITA** Pulisci le sbavature residue sui pezzi utilizzando l'utensile universale "Helper" (H).

**JPN** 万能器具「ヘルパー」(H)を使って、部品のバリを掃除する。

**CHI** 用通用的“帮手”(H)仪器清理零件上的毛刺。

**POR** Limpar as rebarbas das peças com o instrumento universal "Helper" (H).

**POL** Oczyść zadziory na częściach za pomocą uniwersalnego narzędzia "Helper" (H).

**KOR** 유니버설 헬퍼 (H)를 사용하여 불순물을 제거하세요.

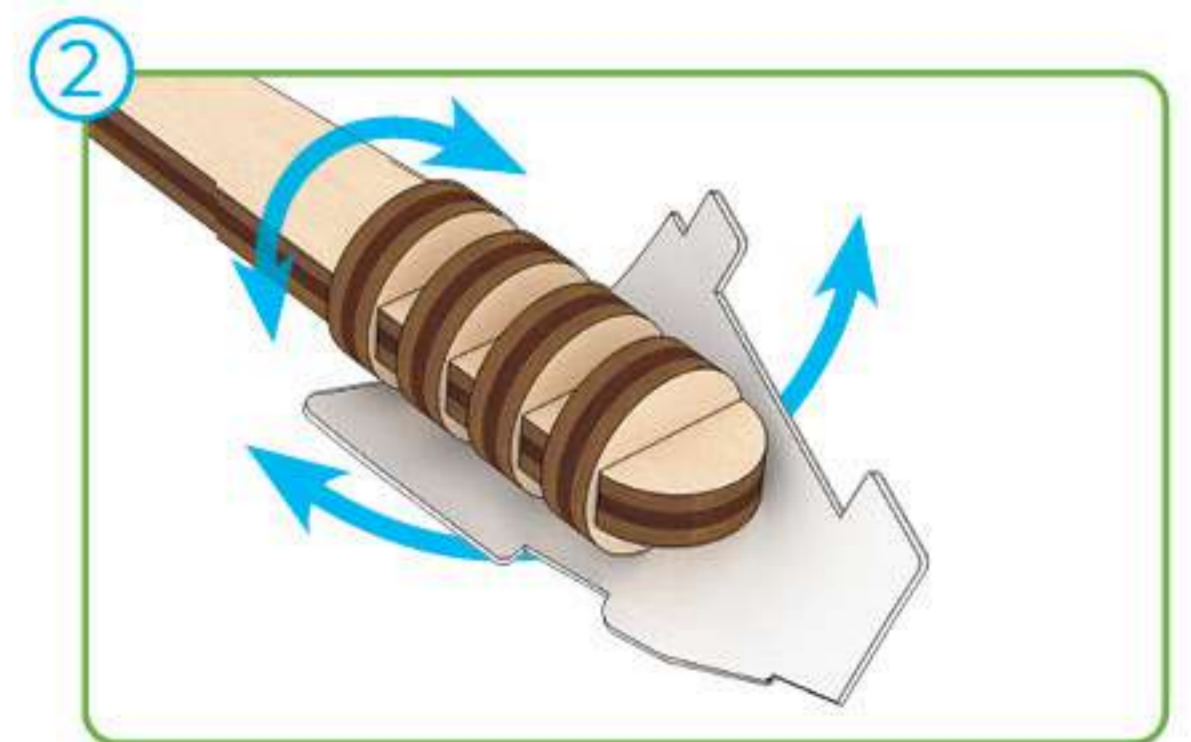
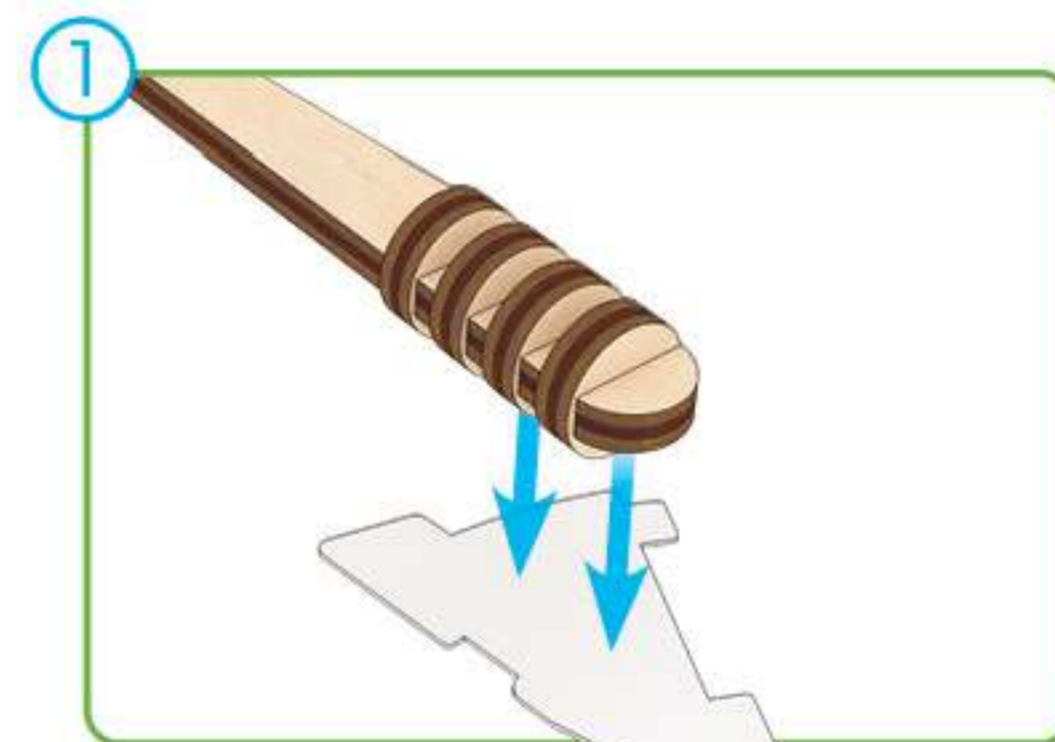
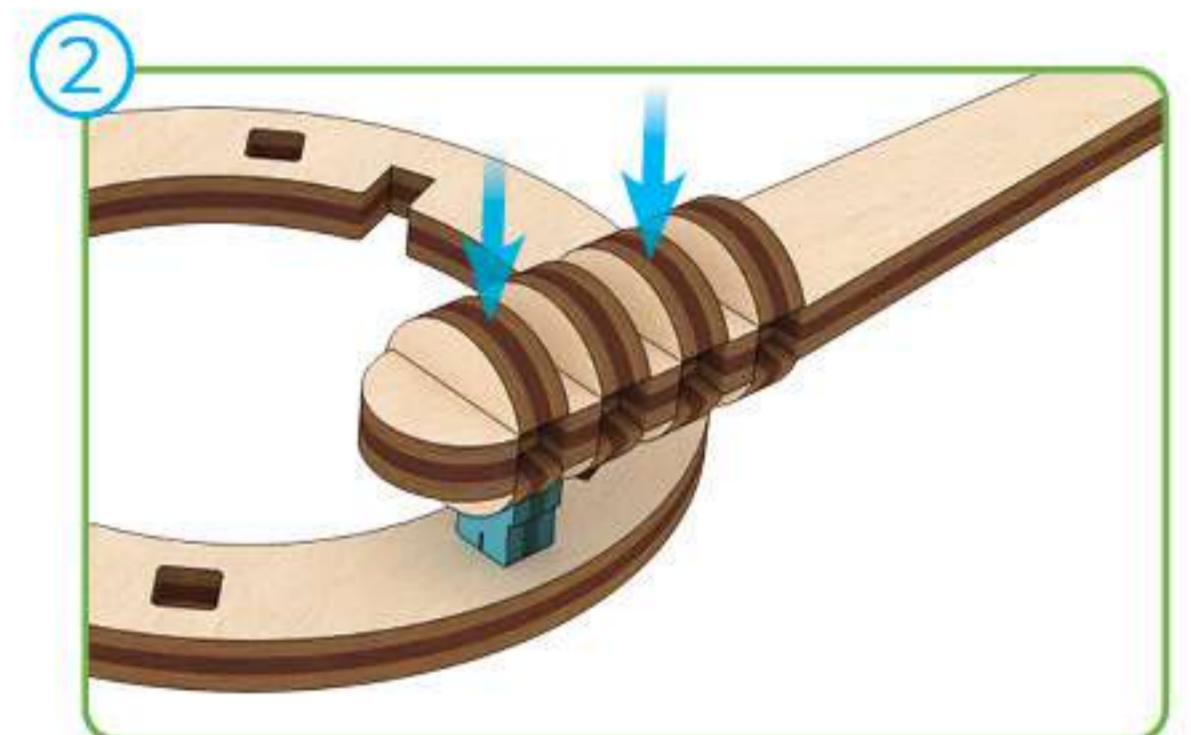
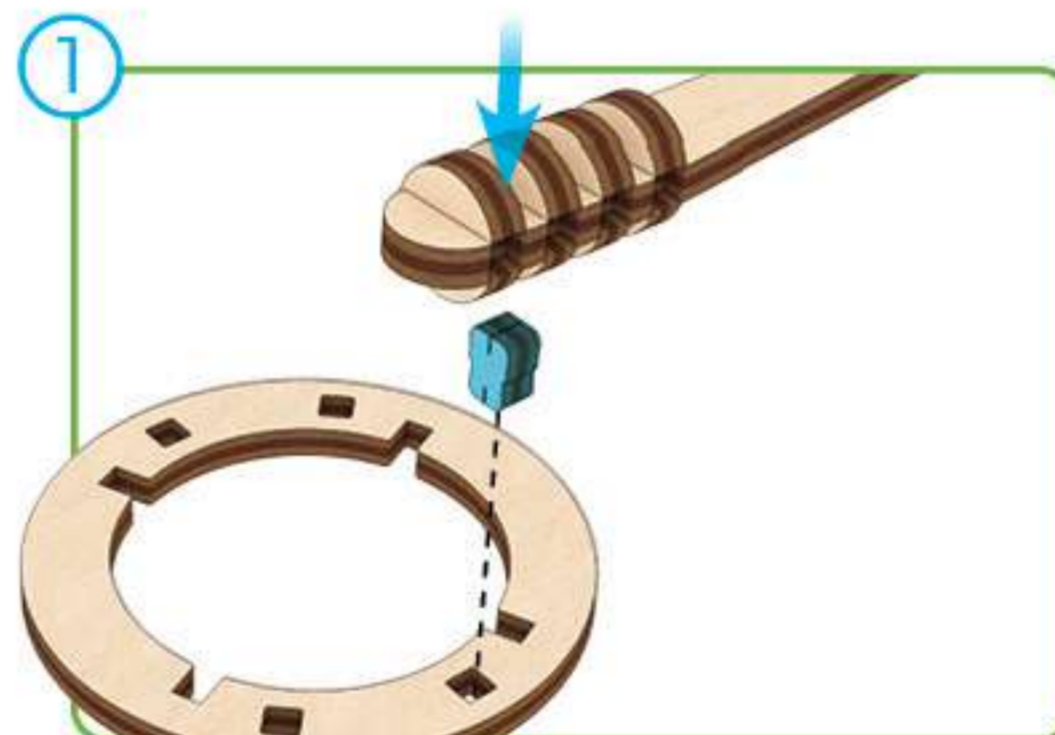
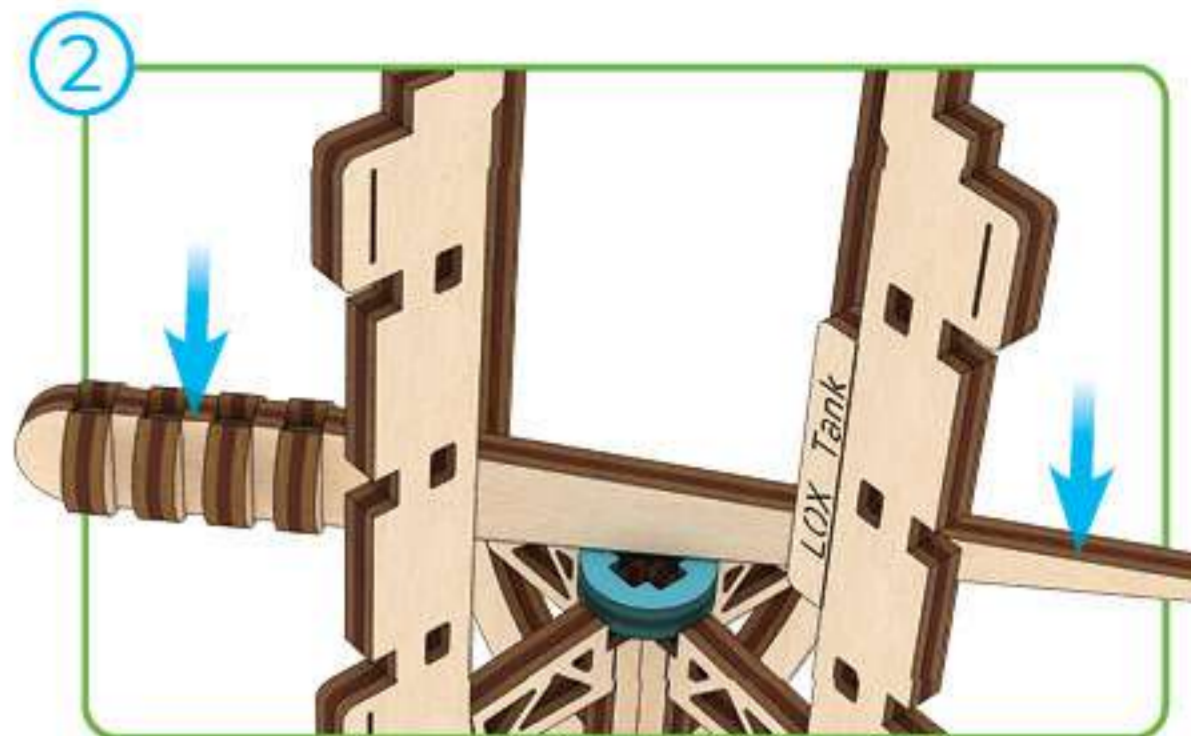
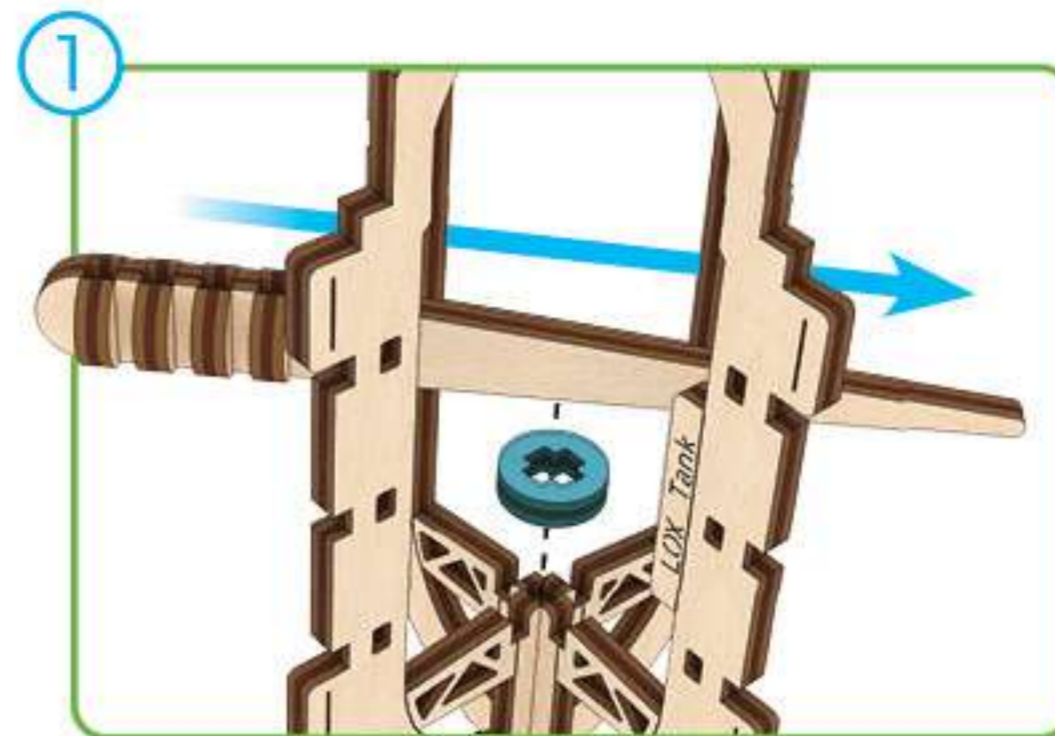

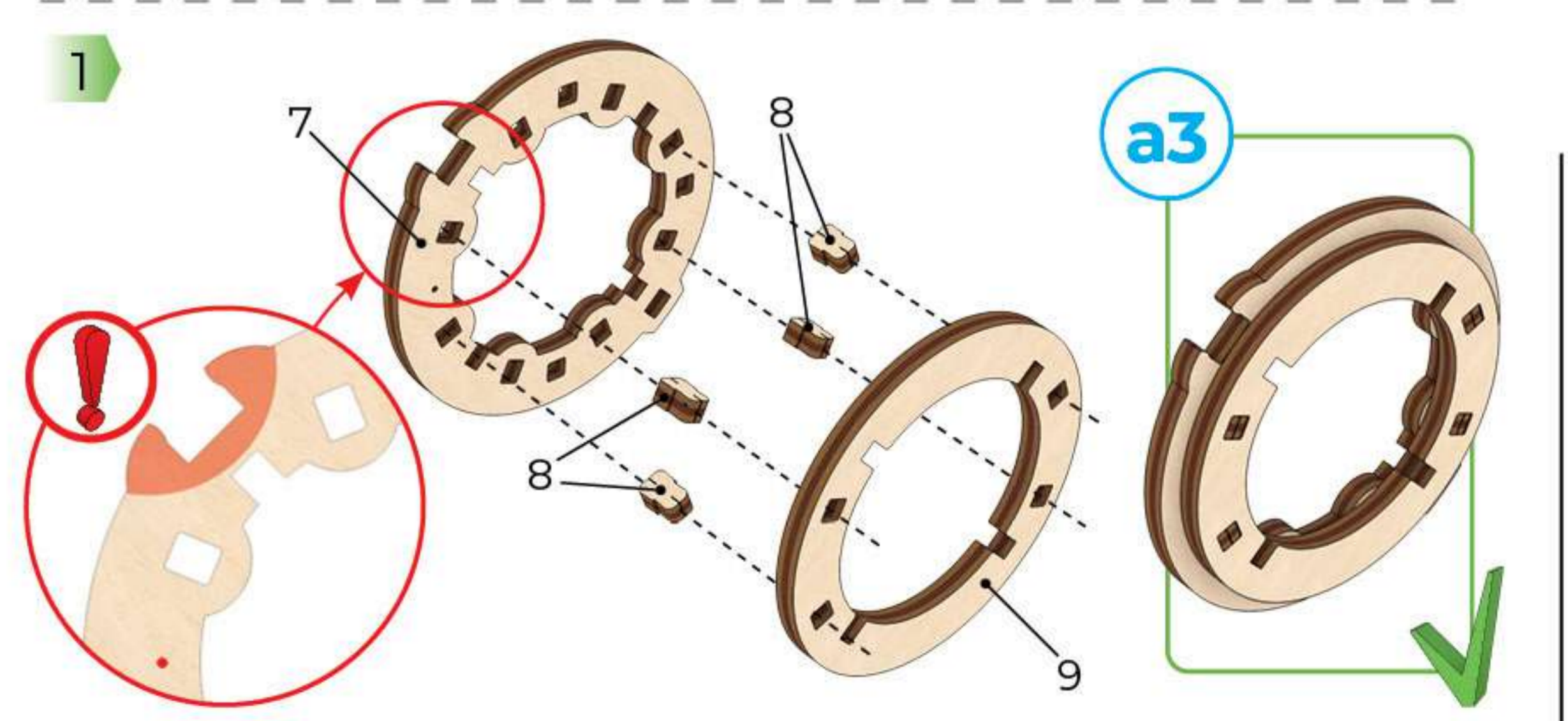
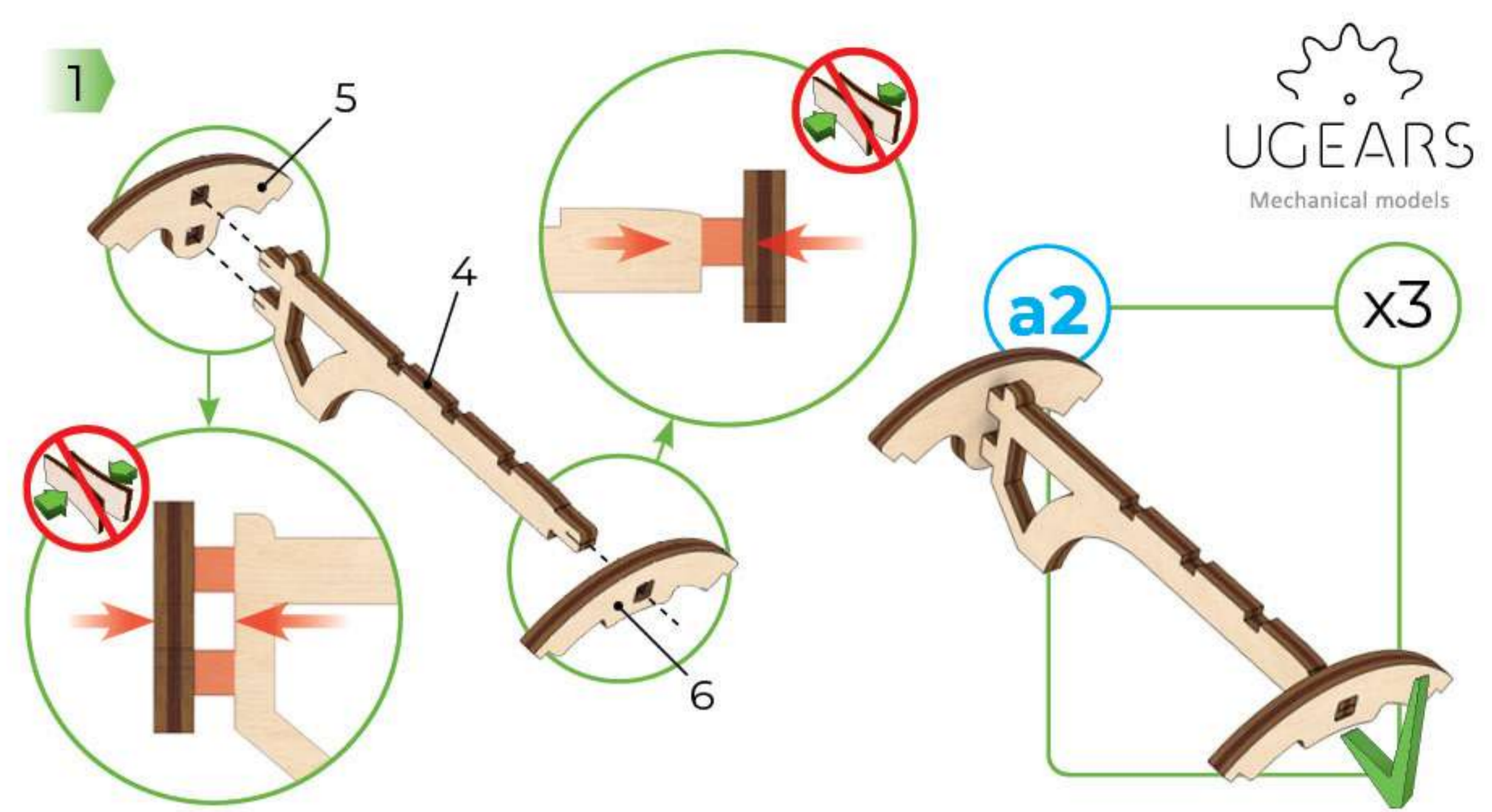
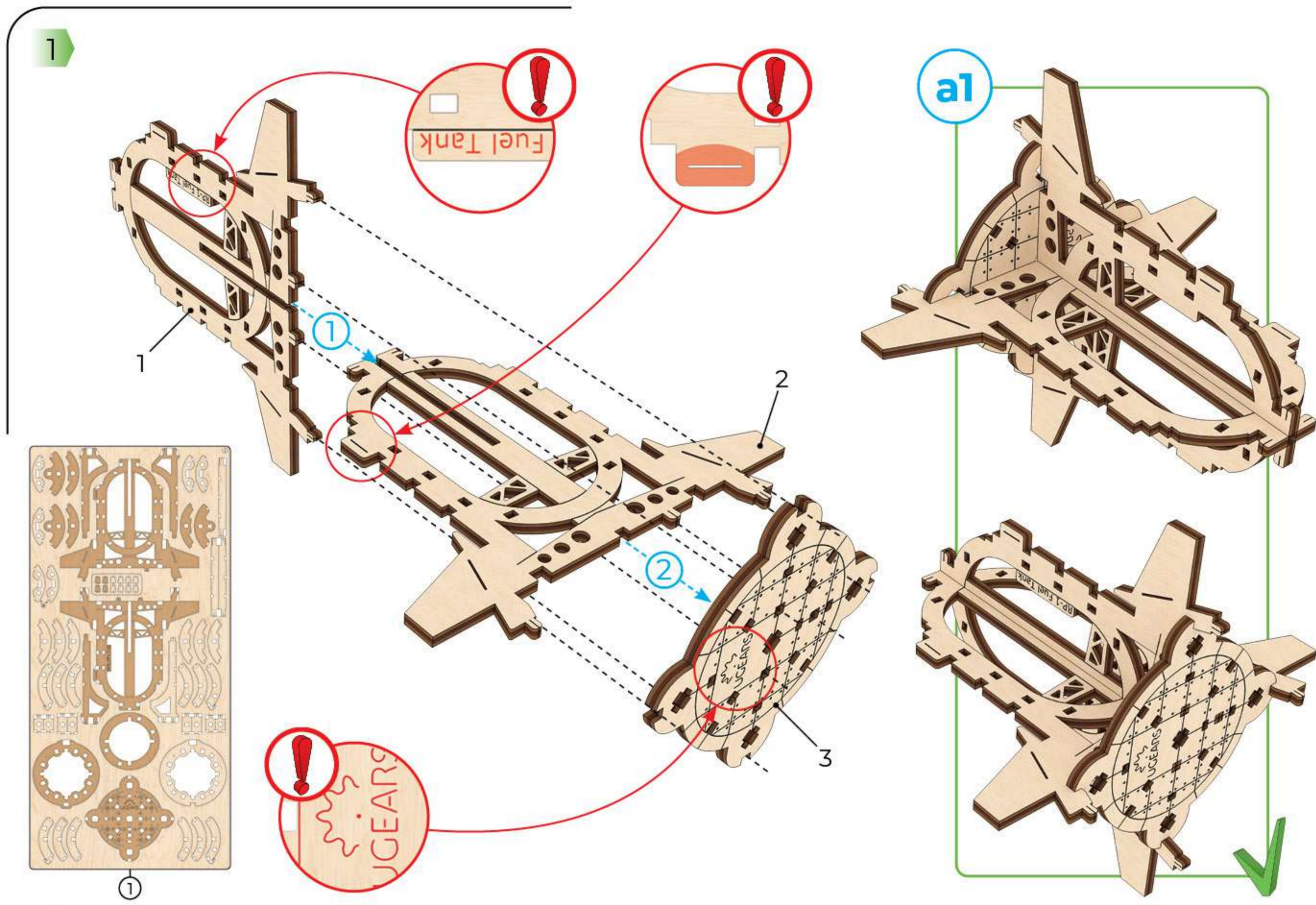

**!** **ENG** Pay attention. Check position of the part. **UKR** Зверніть увагу. Перевірте розташування елемента. **FRA** Faites attention. Vérifiez la disposition de l'élément. **DEU** Bitte Beachten. Prüfen Sie die Einbaulage des Elementes. **SPA** Atención. Compruebe la situación del elemento. **ITA** Prestare attenzione. Controllare la posizione del componente. **JPN** 方向及び位置に注意して組み立ててください。 **CHI** 注意! 检查部件方向和位置。 **POR** Tome cuidado. Verifique as posições das peças. **POL** Zwróć uwagę. Sprawdź lokalizację elementu. **KOR** 방향 또는 위치에 주의해서 조립해 주세요.

**!** **ENG** Press the parts as far as they will go. **UKR** Притисніть деталі до упору. **FRA** Pressez les pièces à fond. **DEU** Drücken Sie die Teile bis zum Anschlag. **SPA** Pulse para detener las piezas. **ITA** Stingere bene i componenti. **JPN** 部品をできる限り押しってください。 **CHI** 用力紧密结合部件。 **POR** Pressione as peças o máximo possível. **POL** Przyciśnij element, aż do oporu. **KOR** 부품을 양쪽에서 눌러서 고정해 주세요.

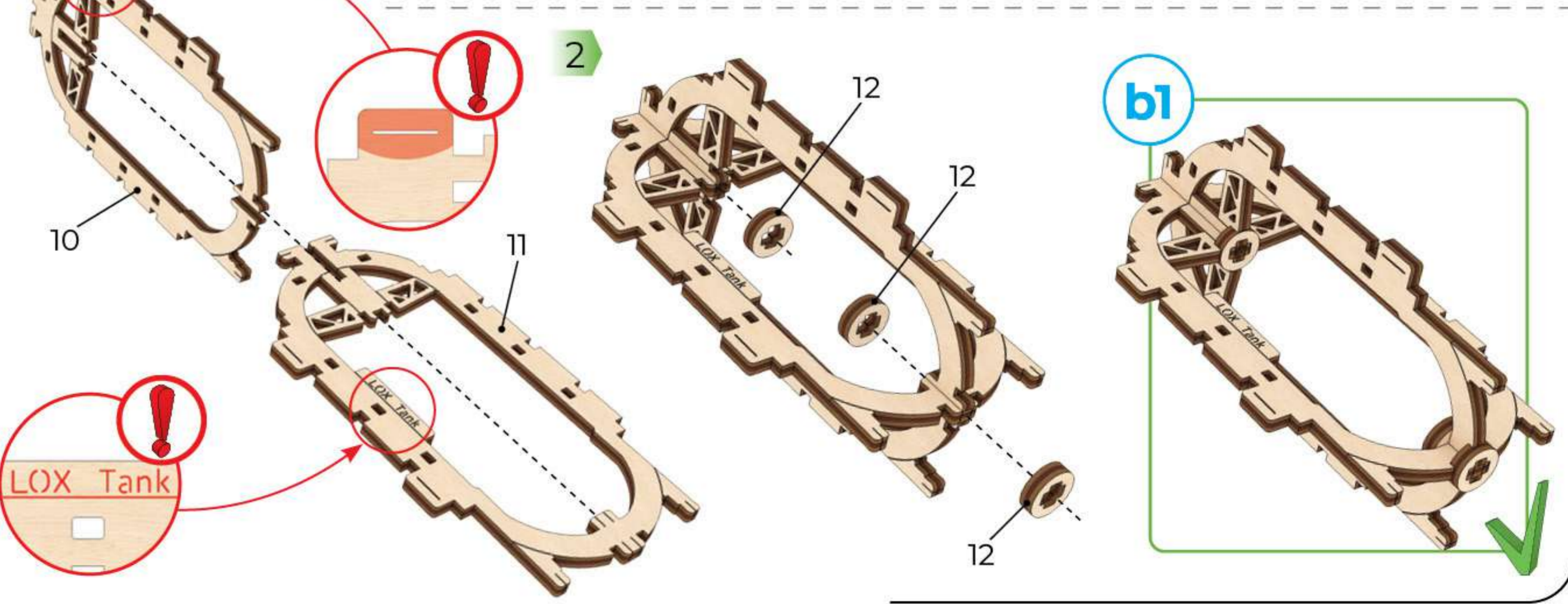
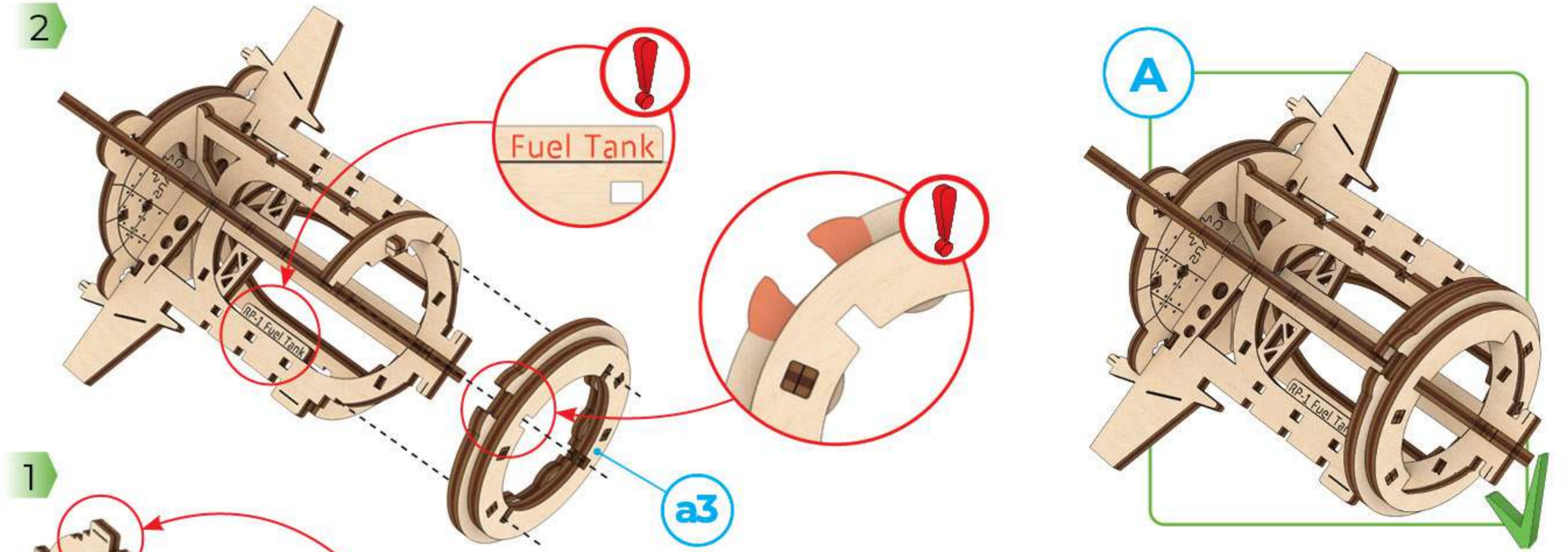
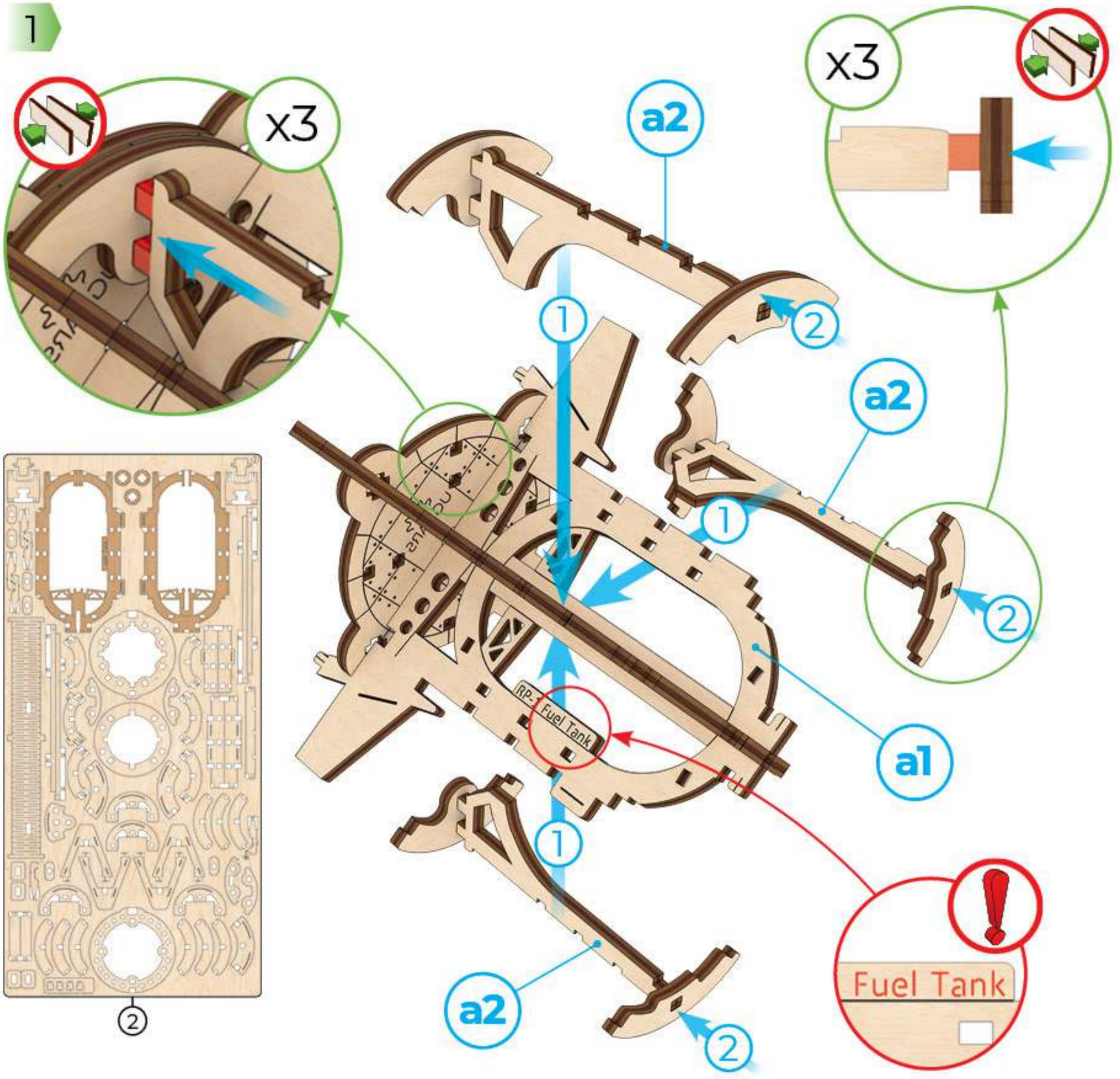

6



**ENG** Press the parts as far as they will go. **UKR** Притисніть деталі до упору. **FRA** Pressez les pièces à fond. **DEU** Drücken Sie die Teile bis zum Anschlag. **SPA** Pulse para detener las piezas. **ITA** Stingere bene i componenti. **JPN** 部品をできる限り押し込んでください。 **CHI** 用力緊密結合部件 **POR** Pressione as peças o máximo possível. **POL** Przyciśnij element, aż do oporu. **KOR** 부품을 양쪽에서 눌러서 고정해 주세요.

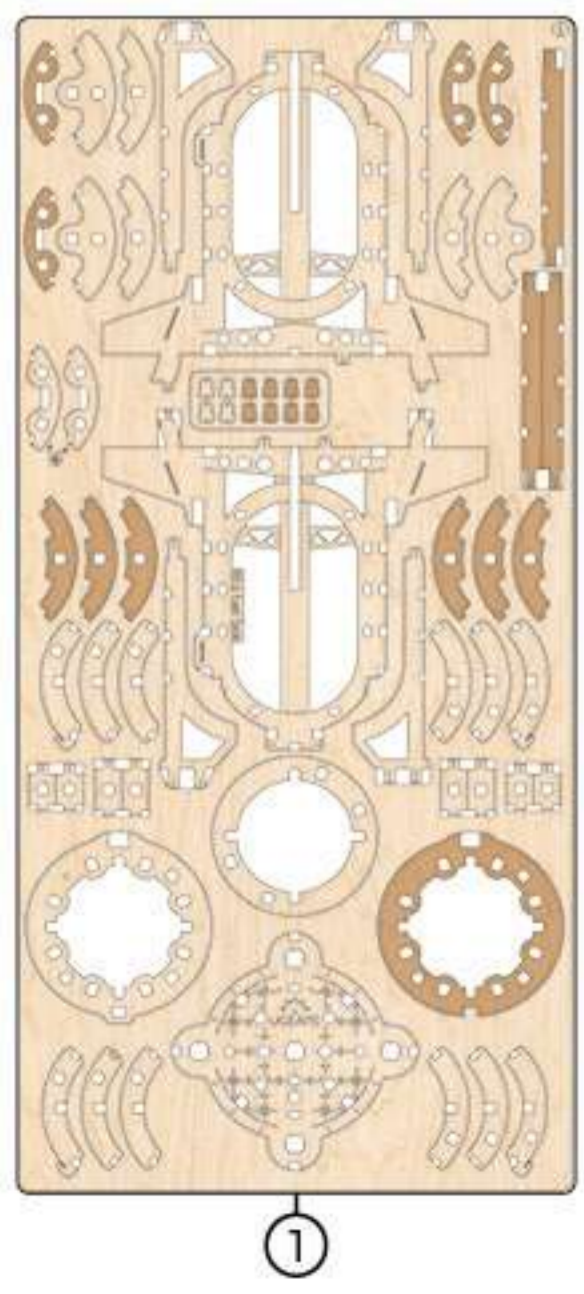
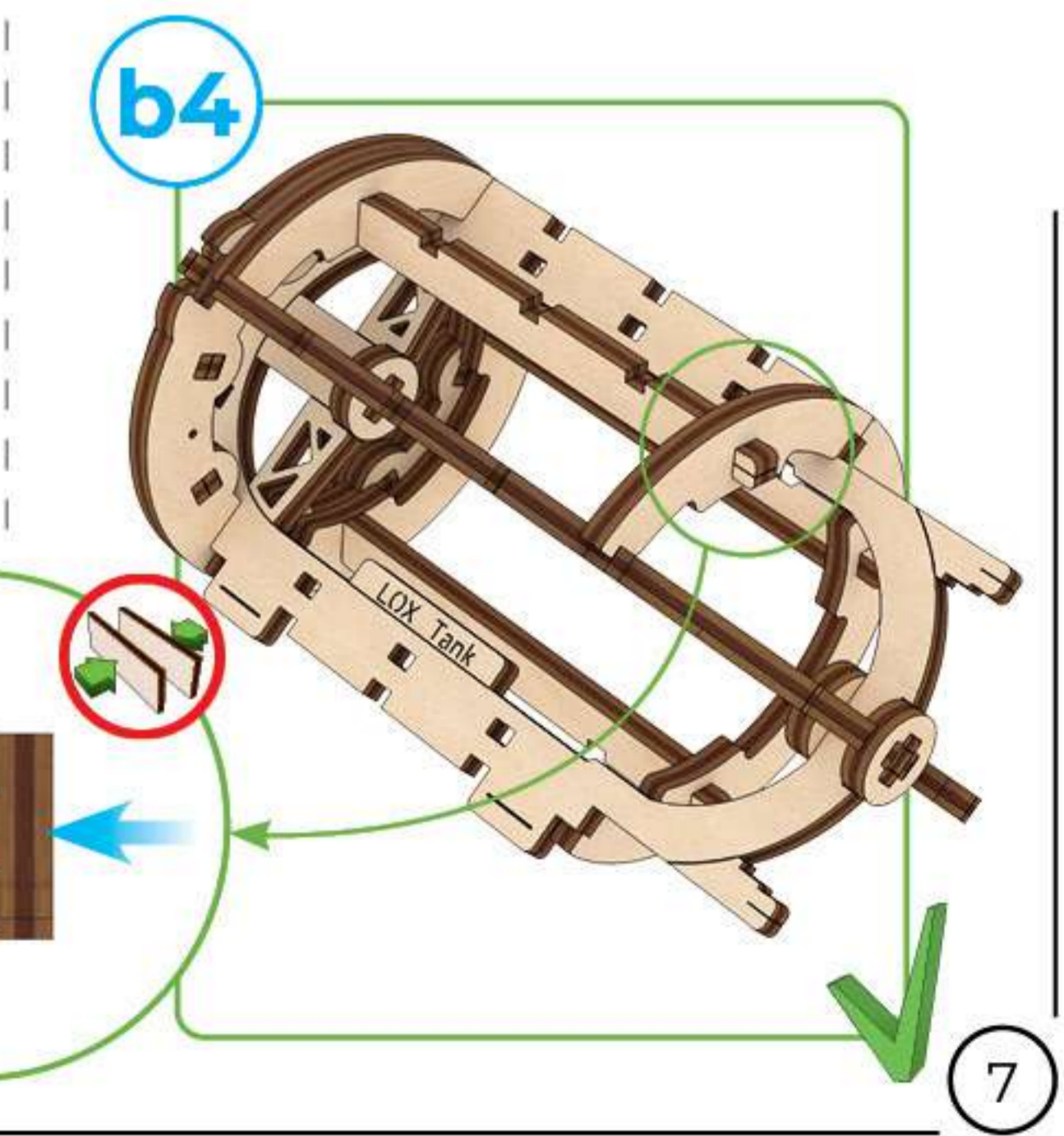
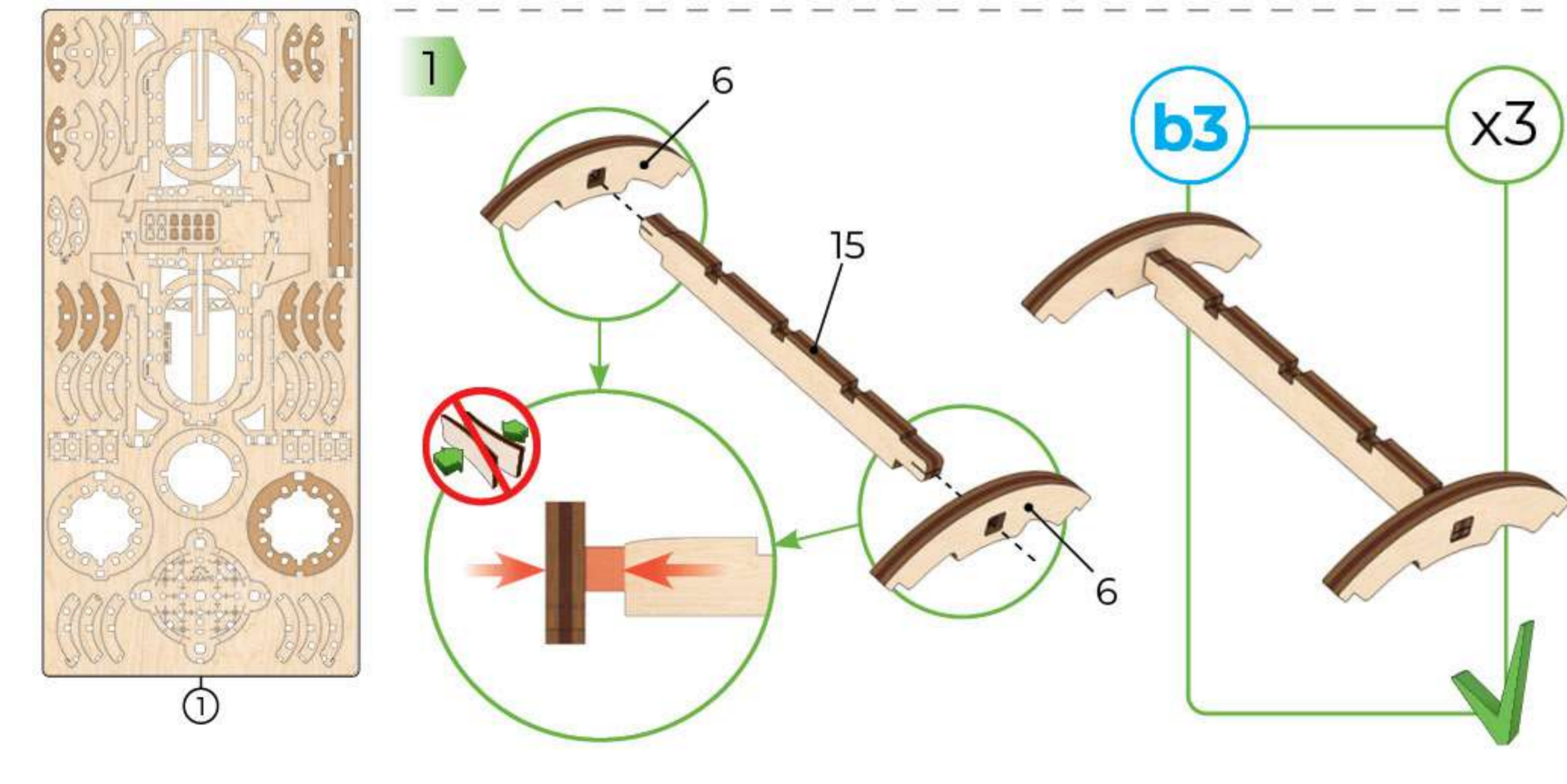
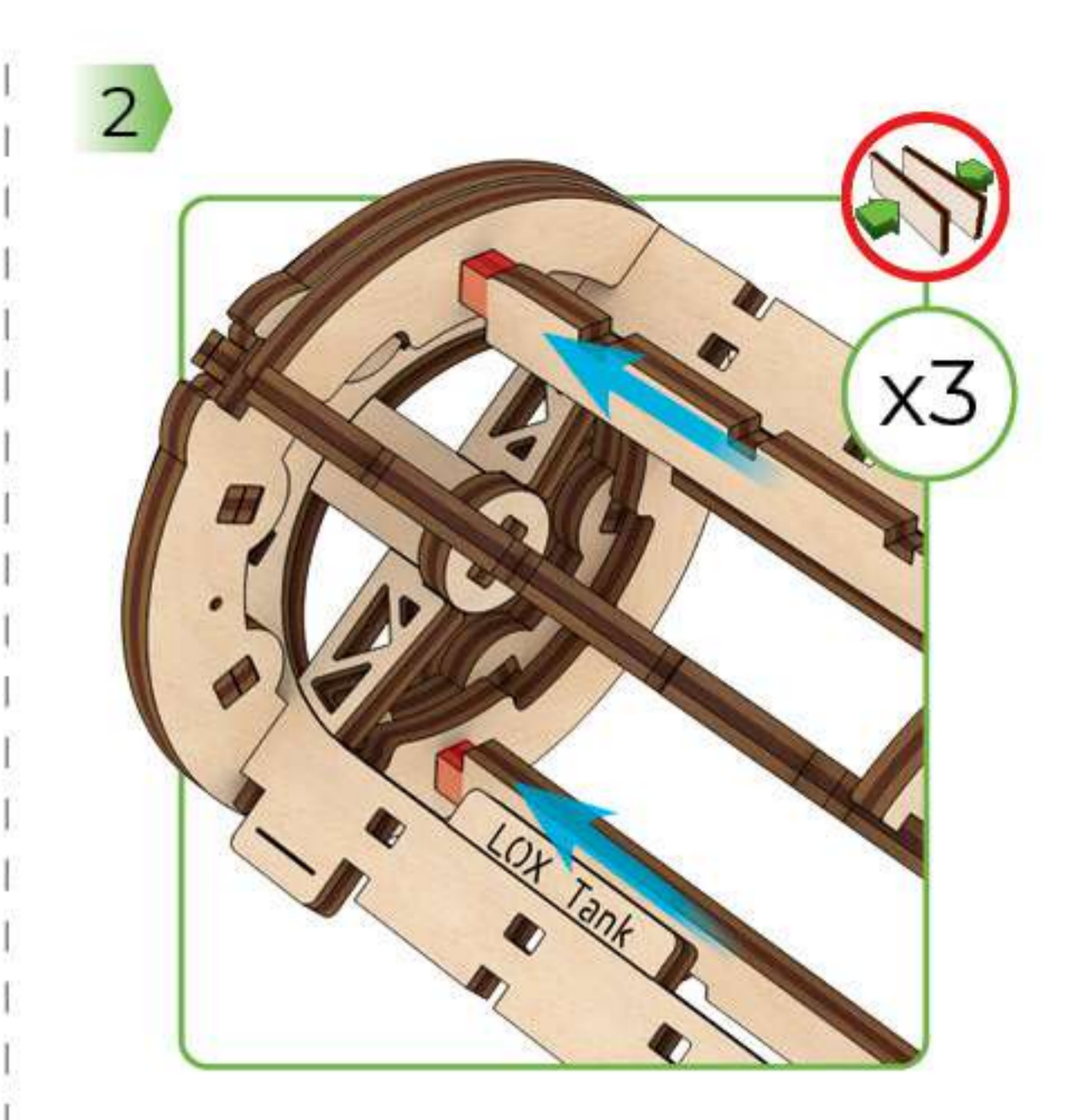
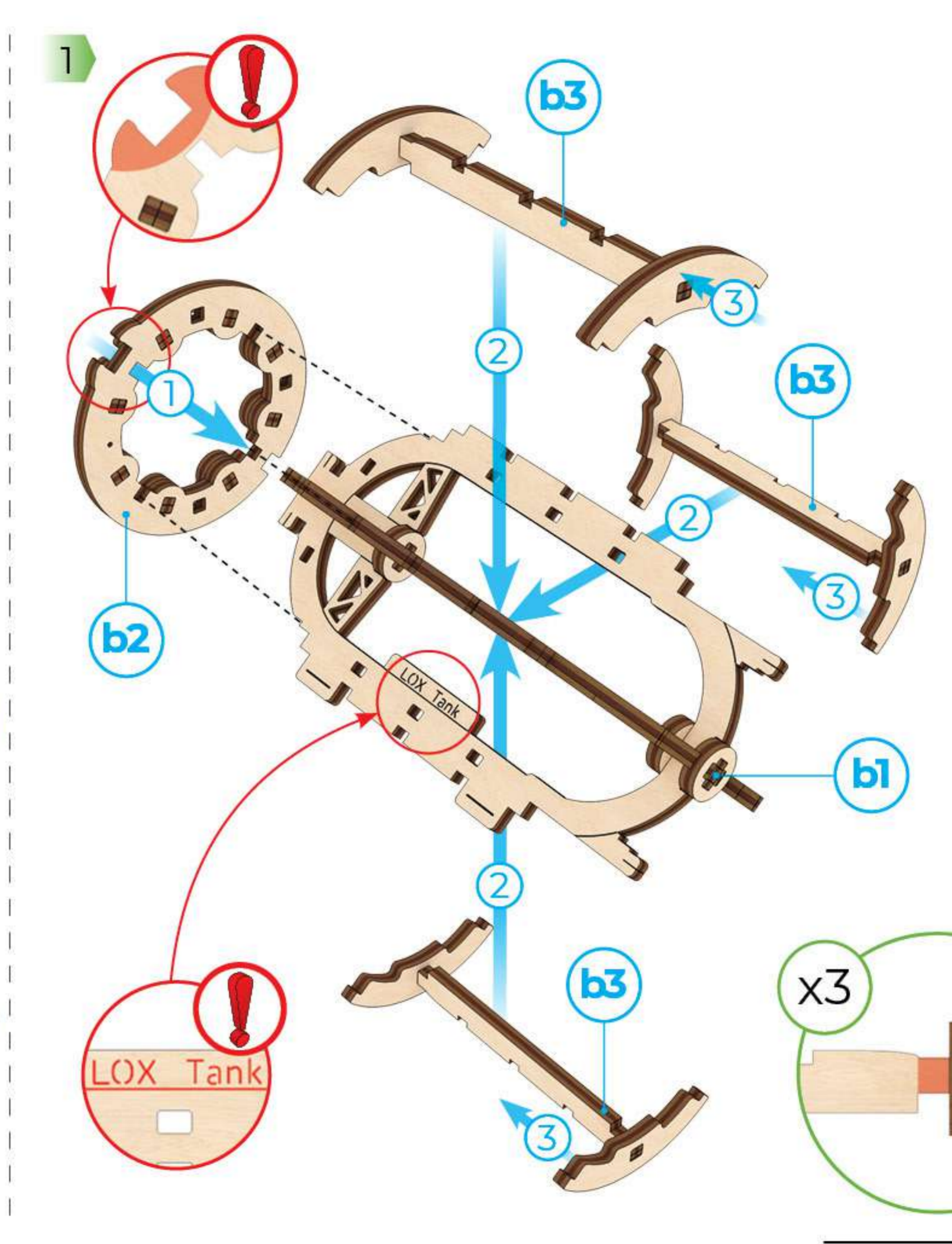
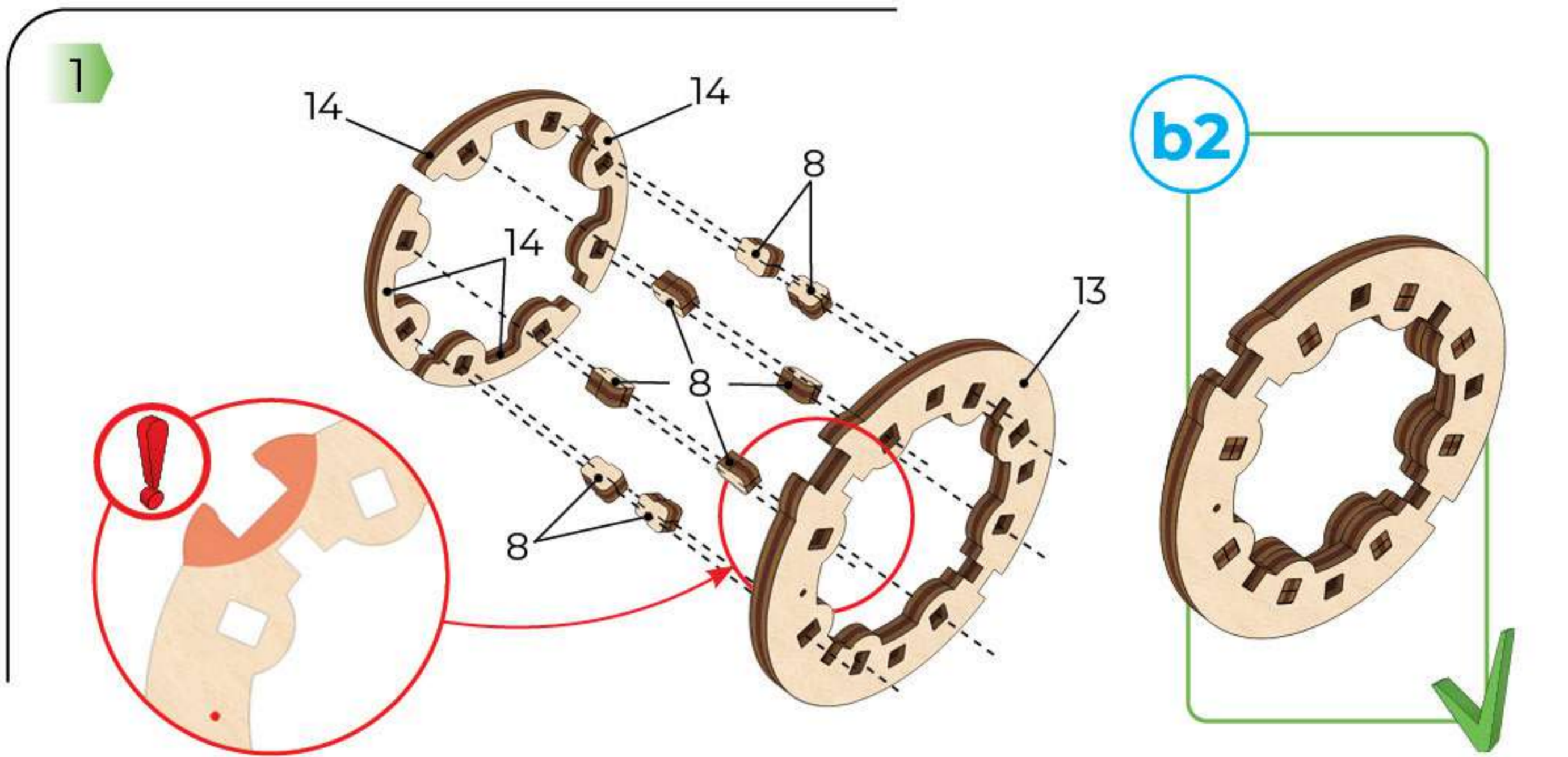

Mechanical models

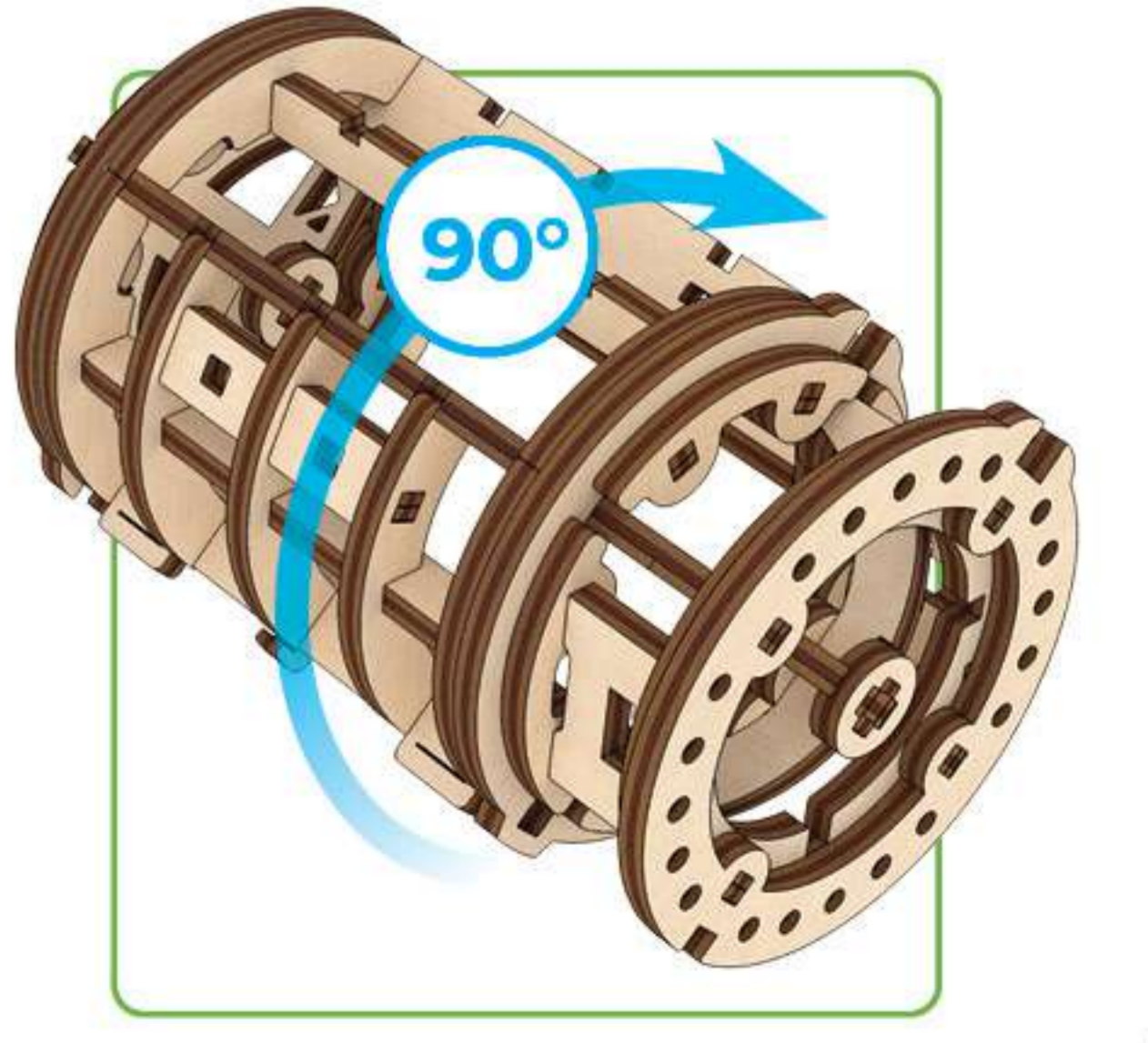
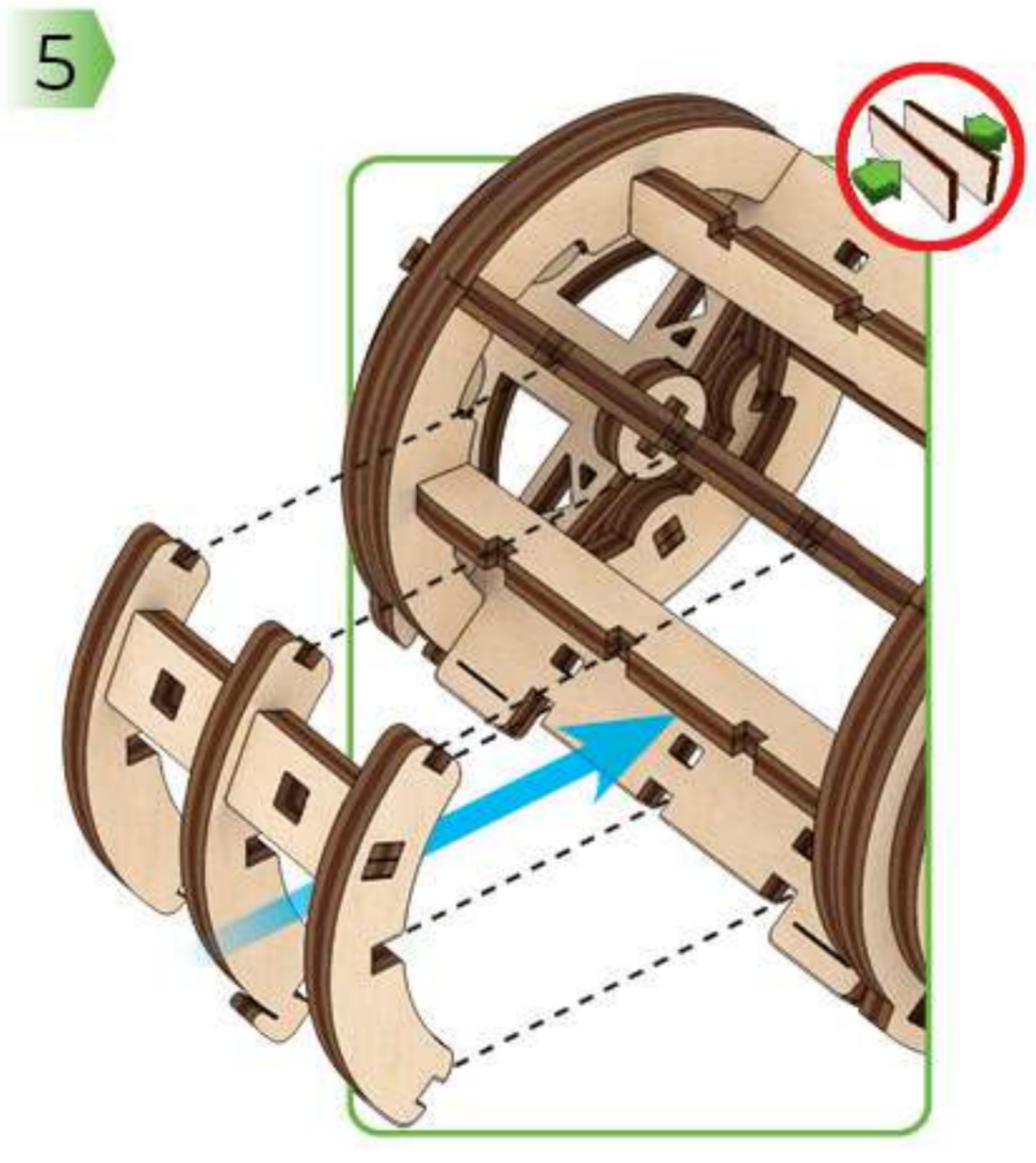
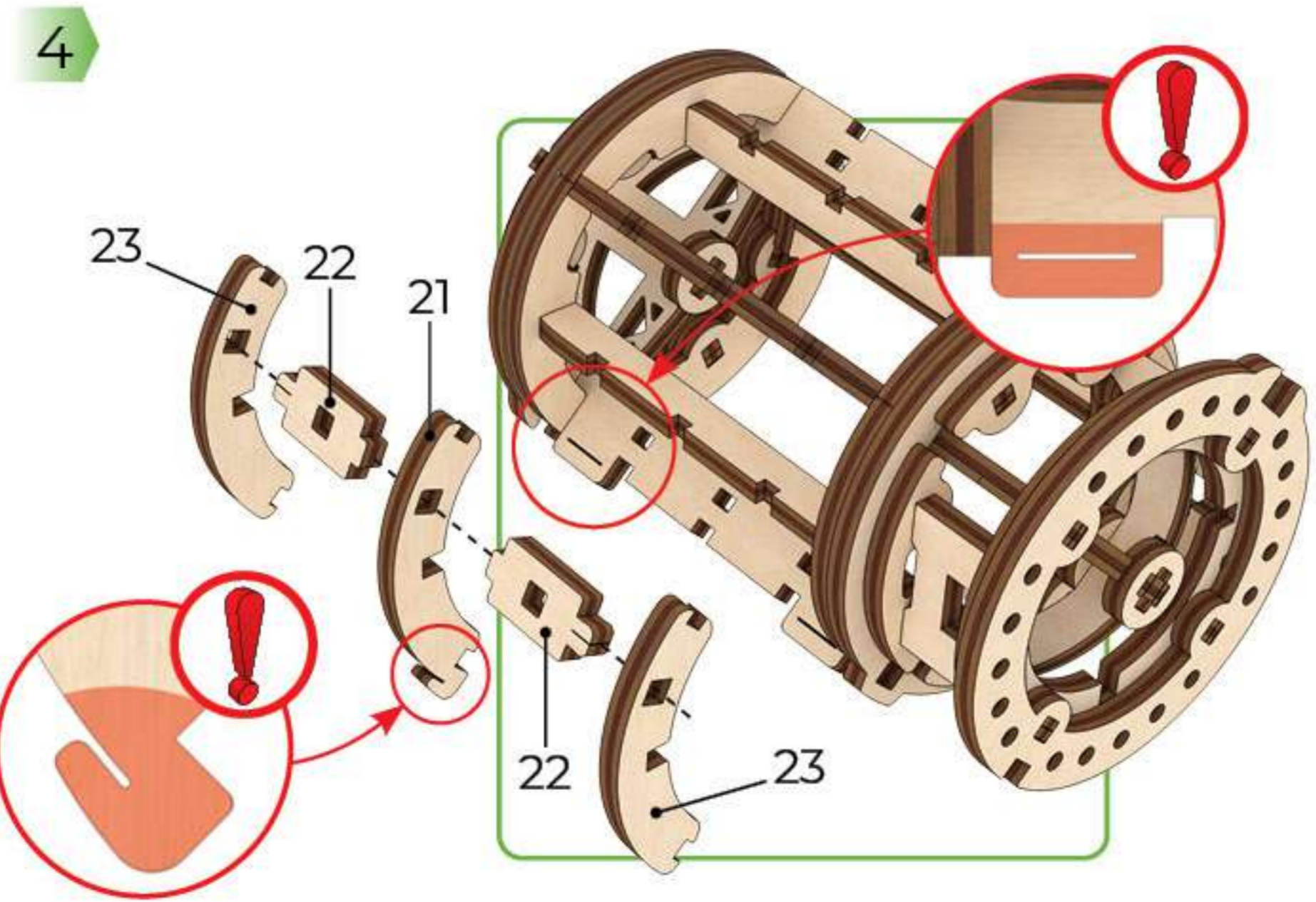
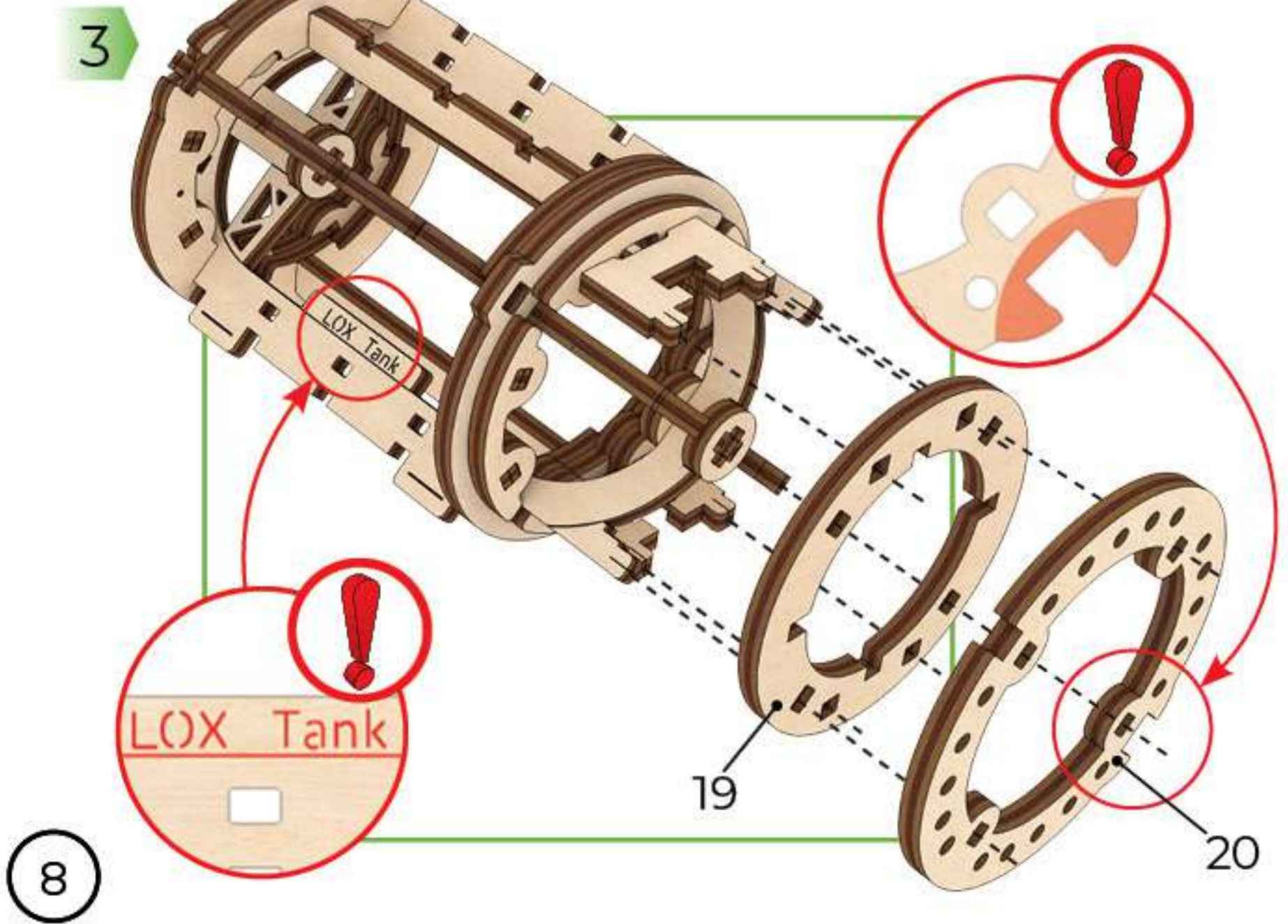
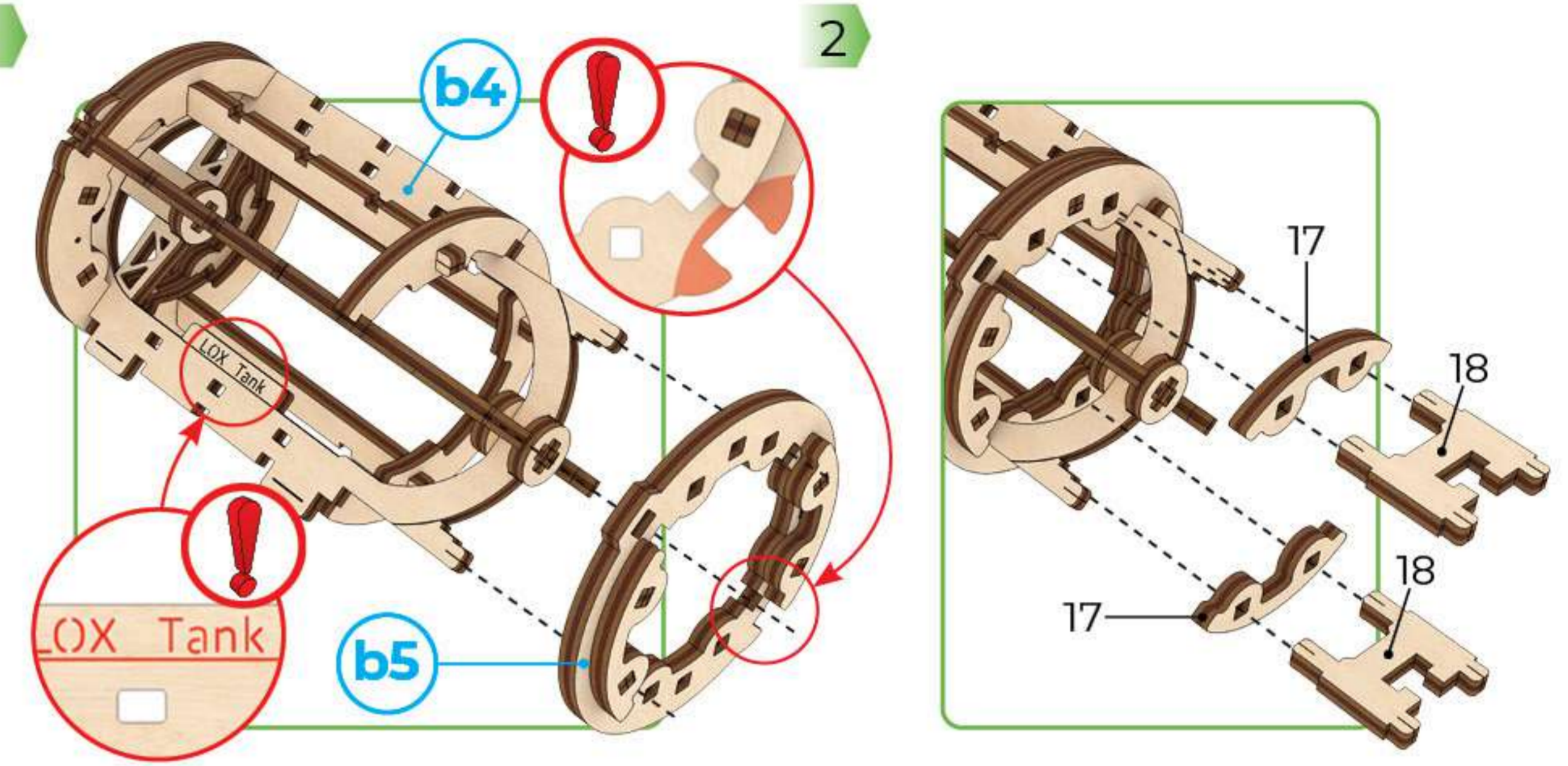
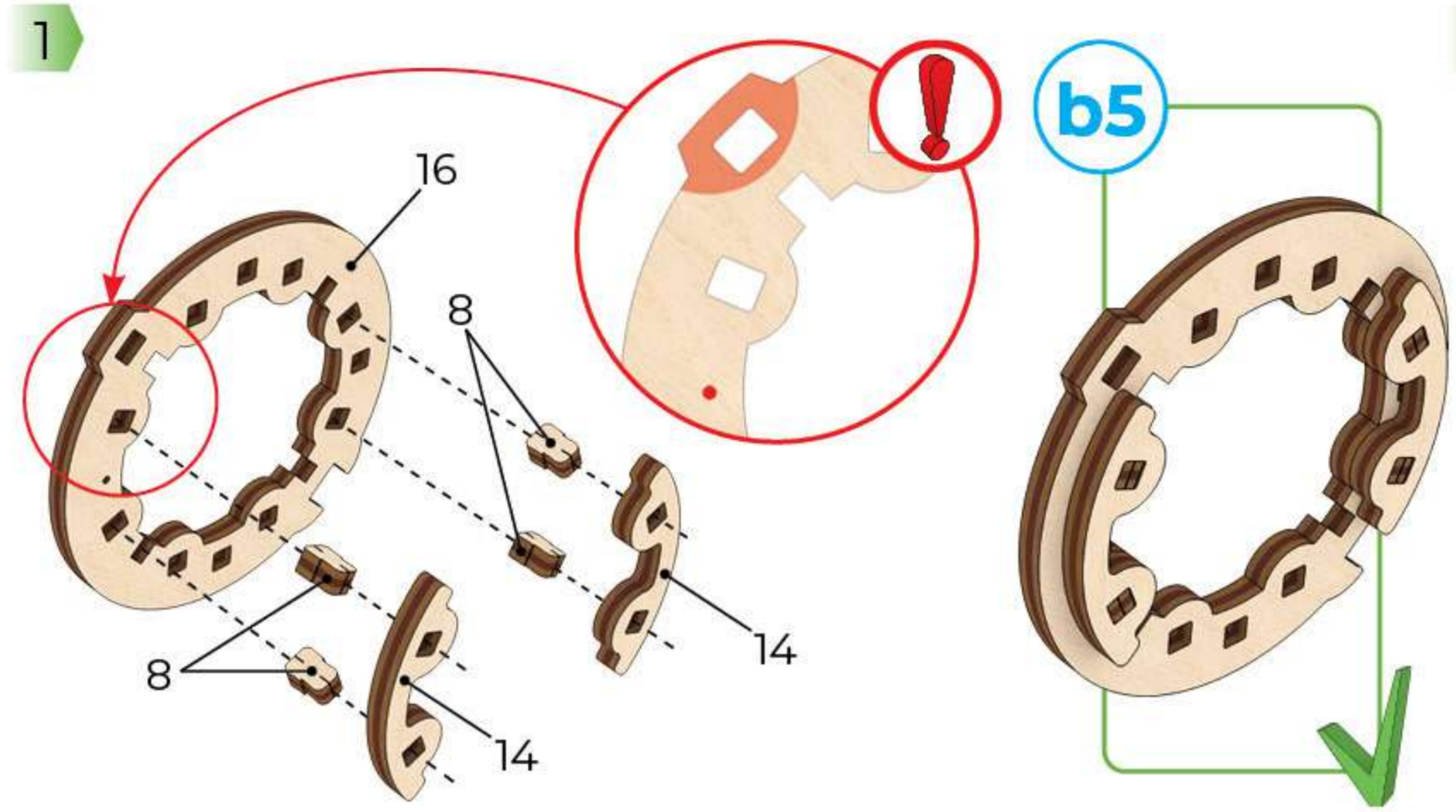
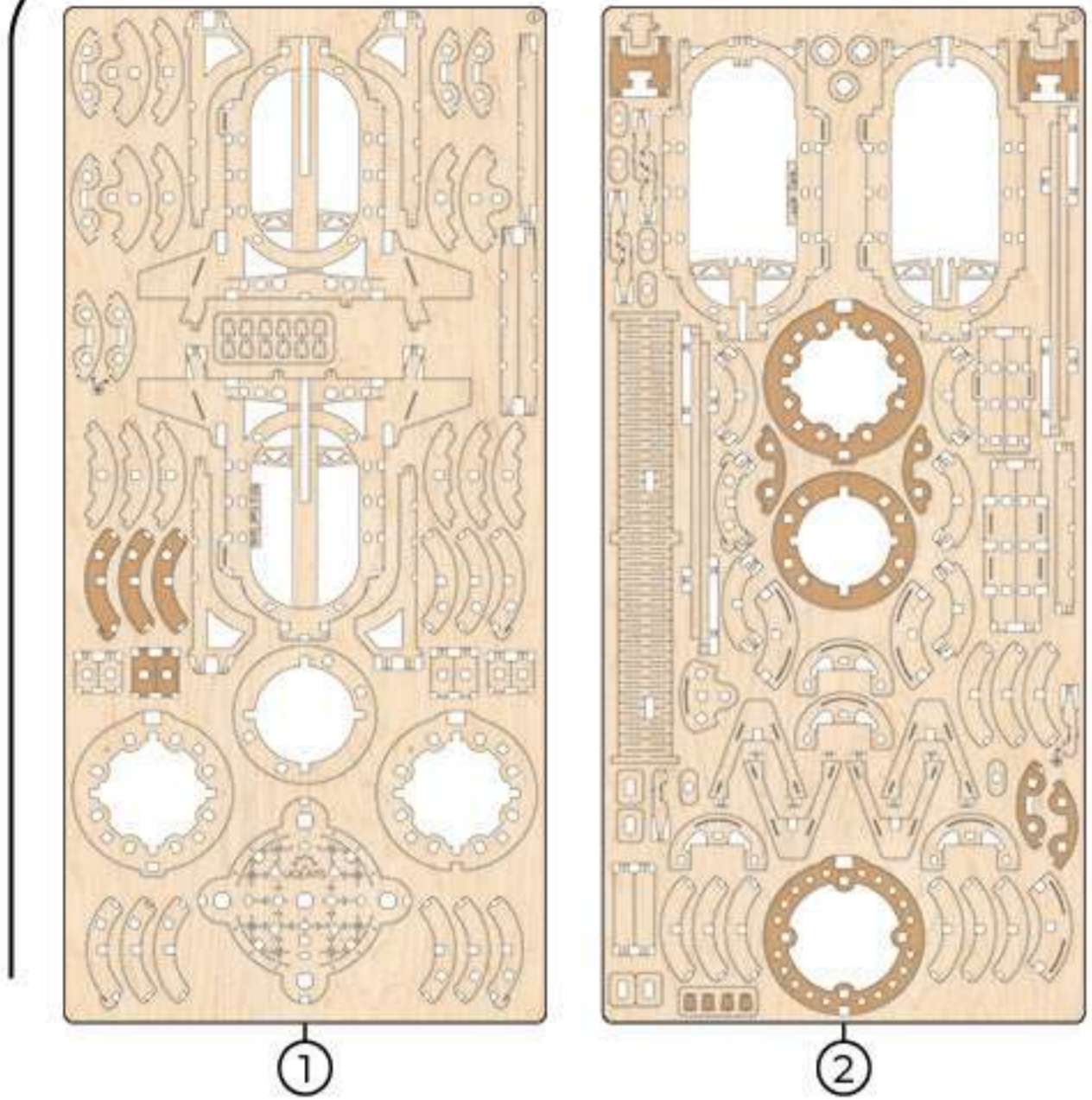



6

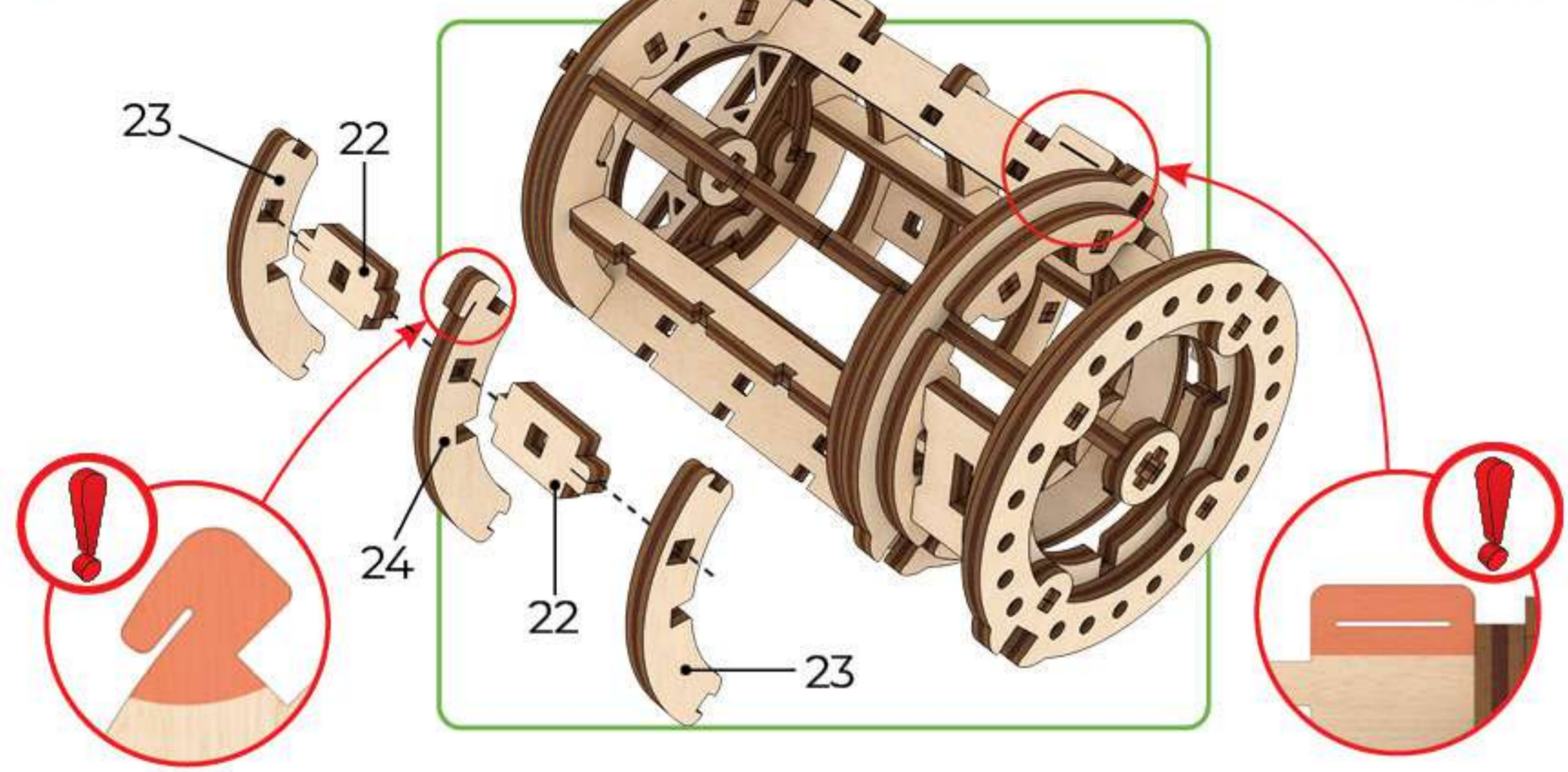

7

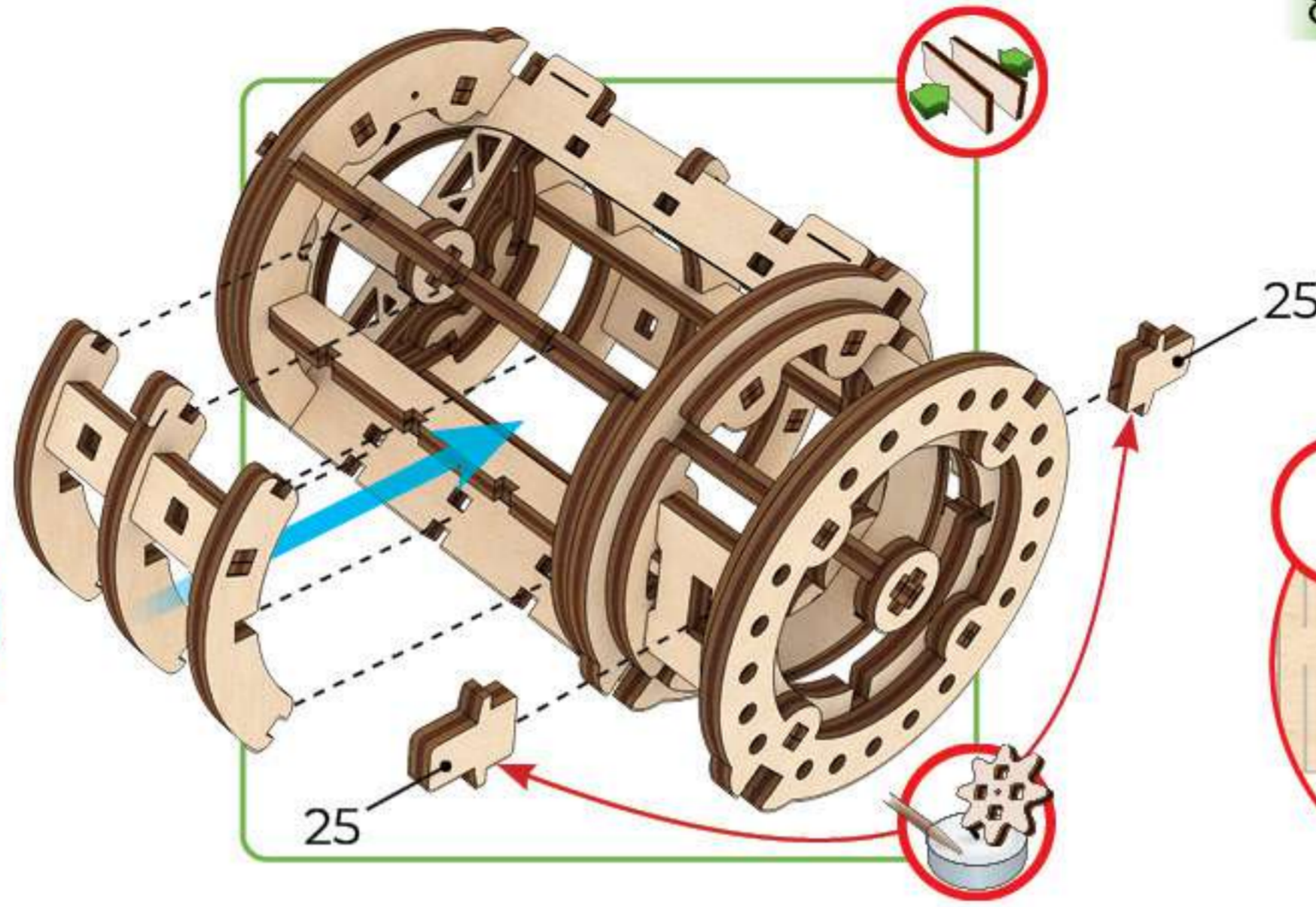

8

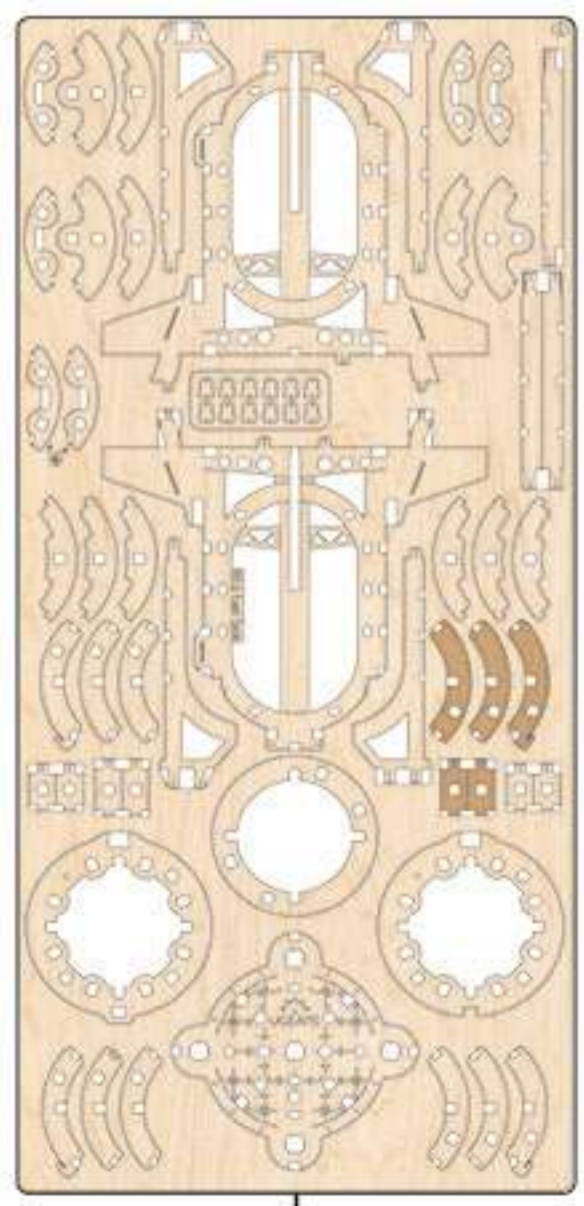
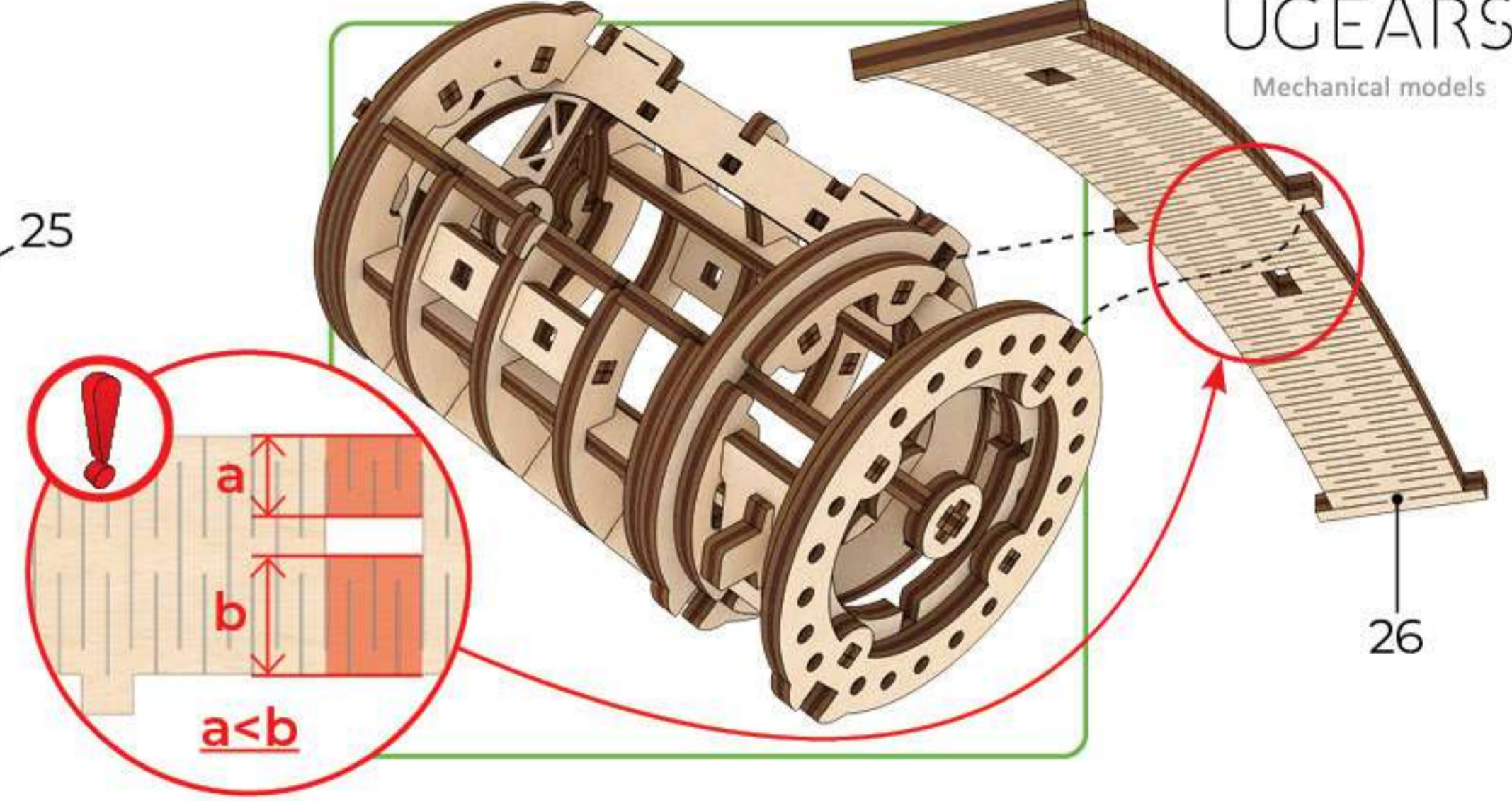

1

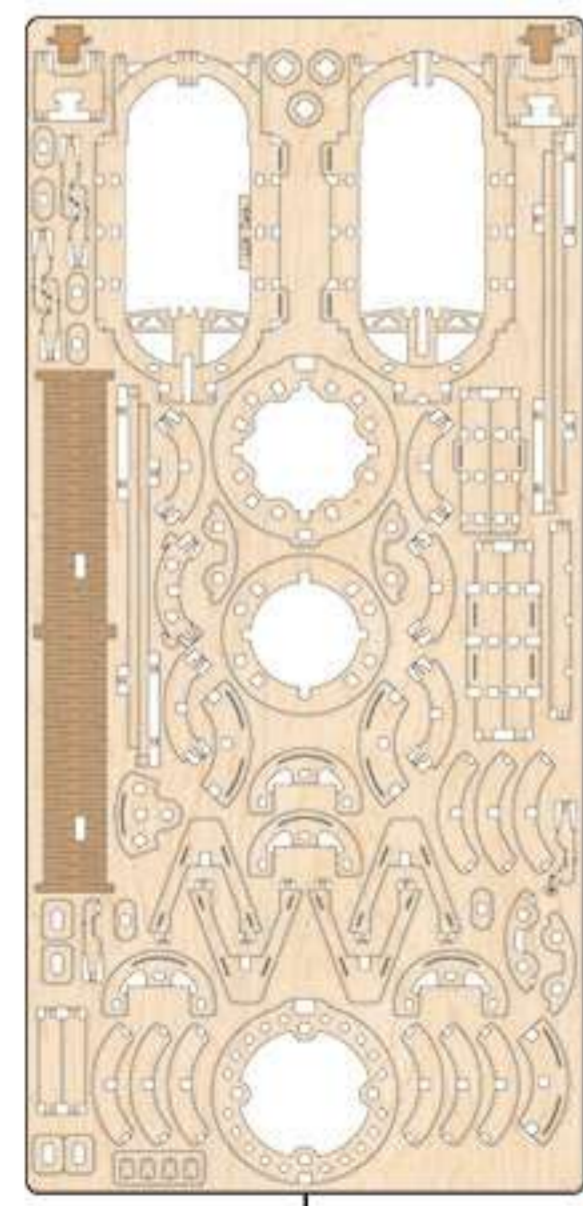

2

9

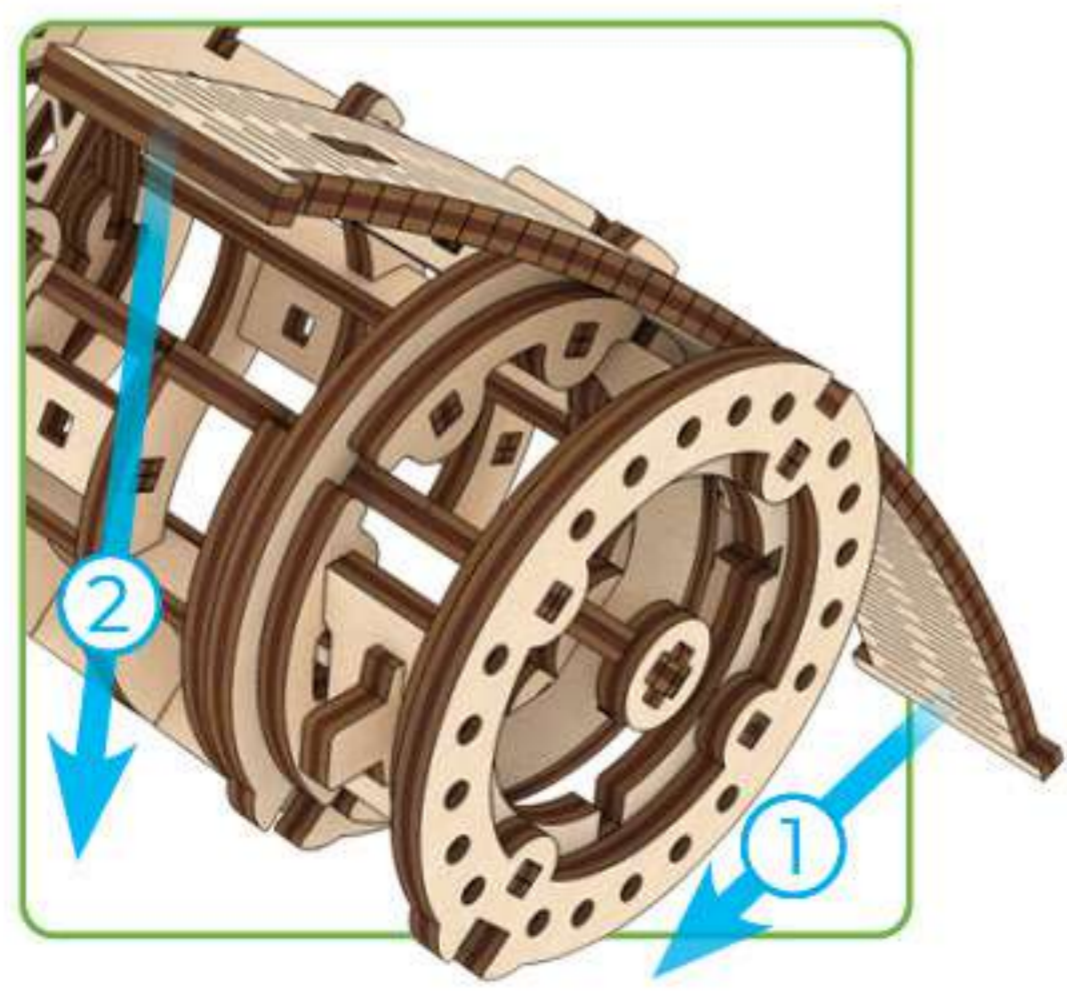

10

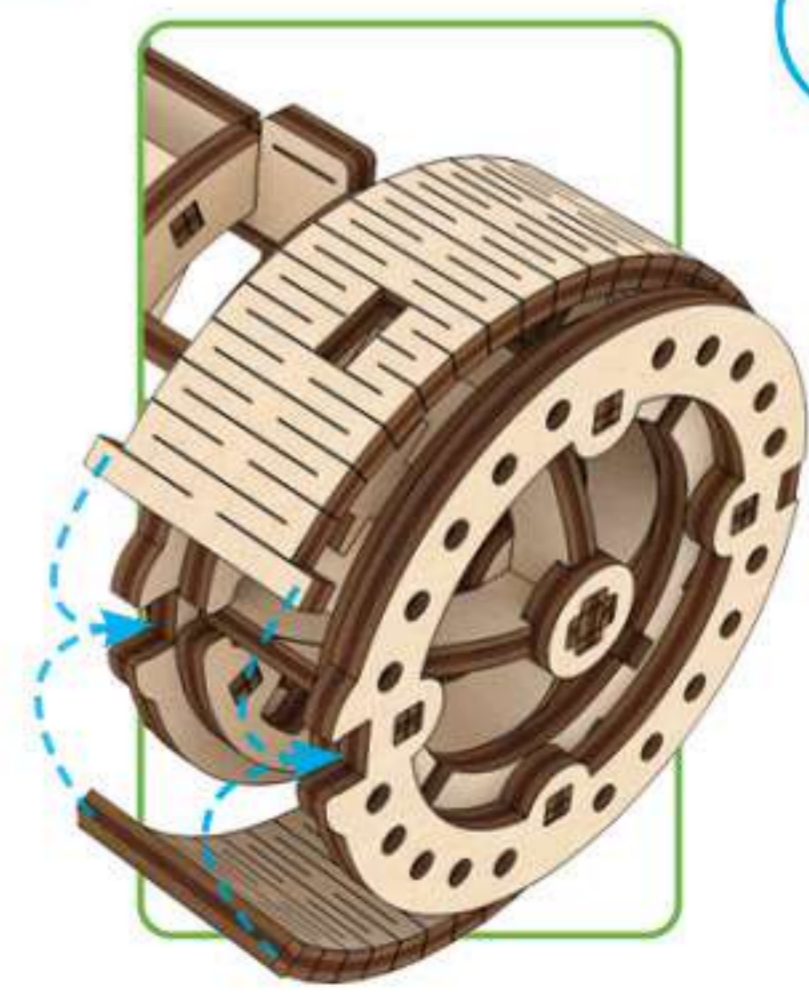
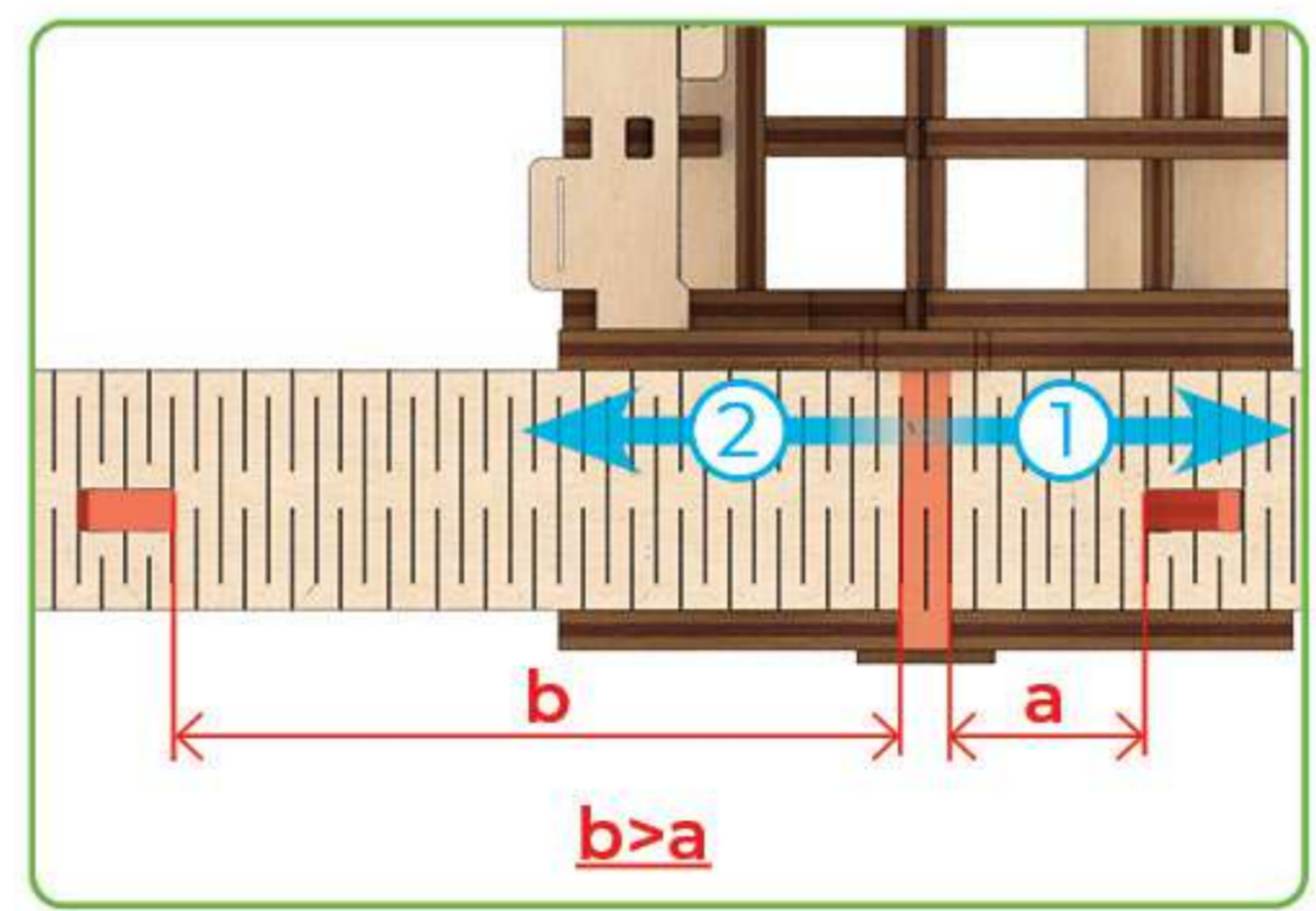

B

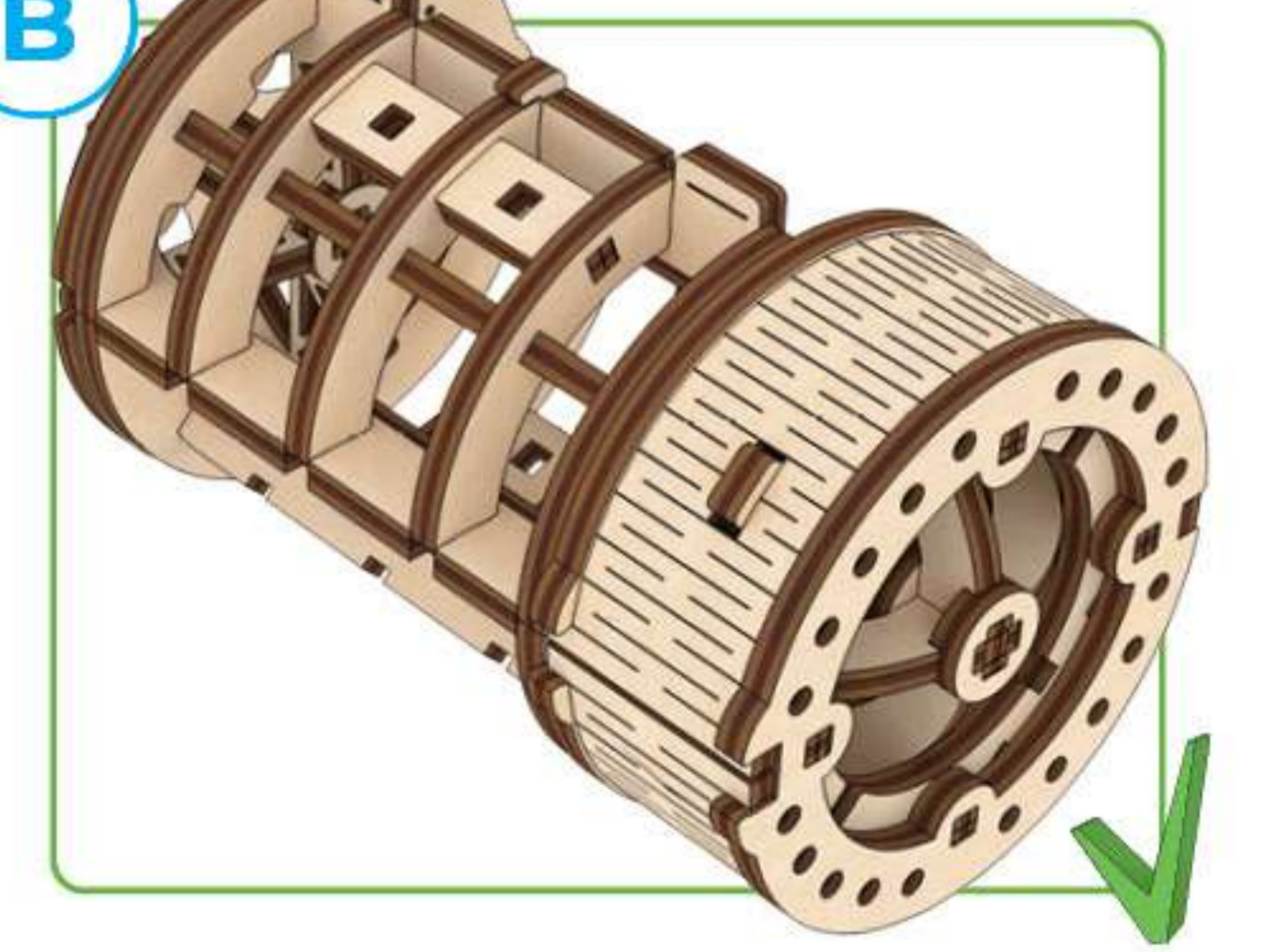

**ENG** Wax the part with a regular candle (rub with a candle). **UKR** Змастіть деталь звичайною свічкою (потріть об свічку). **FRA** Lubrifiez la pièce avec une bougie ordinaire (frottez contre la bougie). **DEU** Reiben Sie das Teil mit einer einfachen Kerze etwas ein. **SPA** Engrase la pieza con una vela común (frote con una vela). **ITA** Incerare il componente (Sfregare con la cera). **JPN** された部分に潤滑剤として口ウソクを塗ってください。 **CHI** 用普通蜡烛涂抹润滑部件 **POR** Encere a peça com uma vela comum (esfregar numa vela). **POL** Przesmaruj zwykłą świecą. **KOR** 표시된 부분에 윤활을 위해 조를 칠해 주세요.

Mechanical models

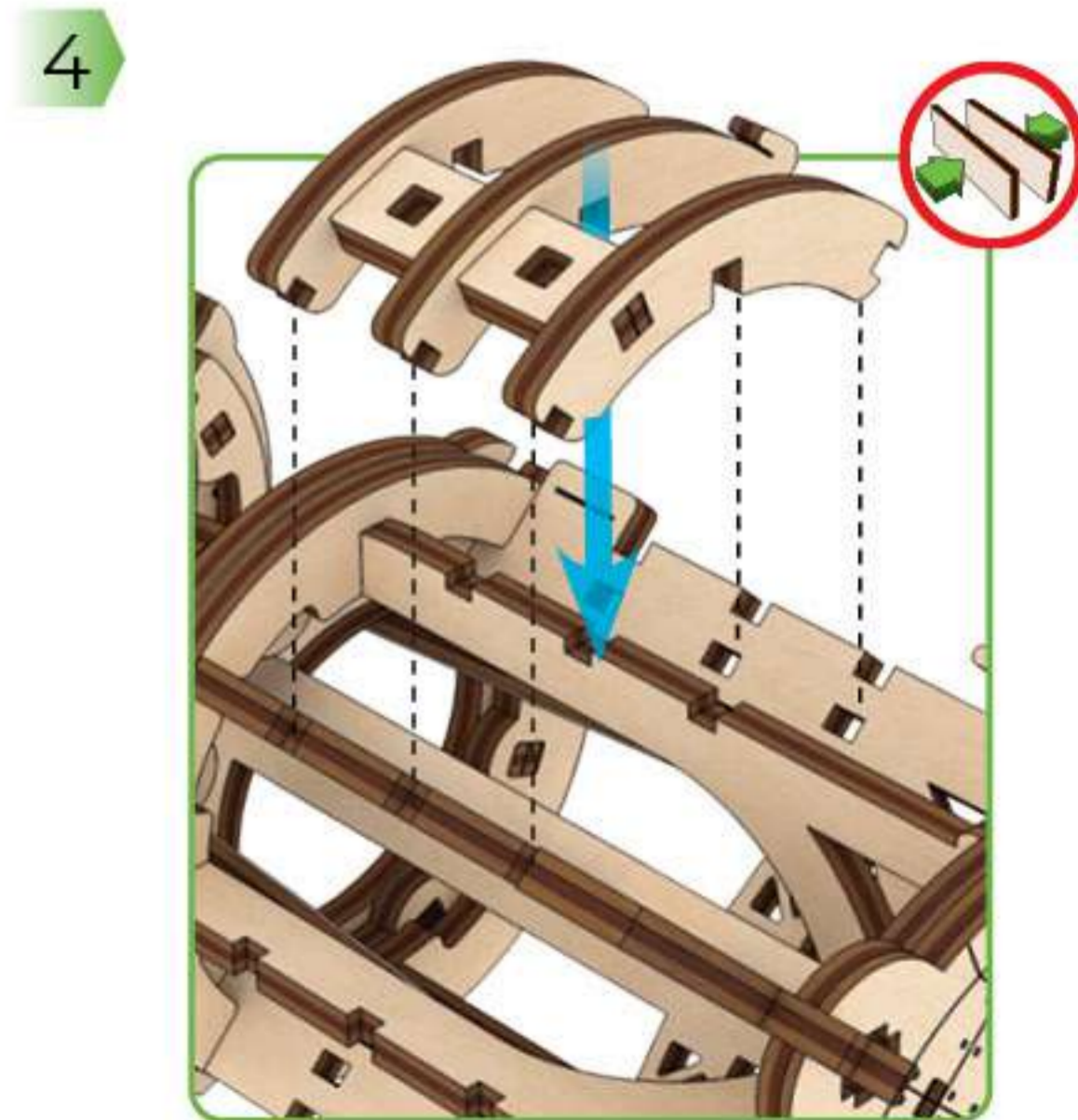
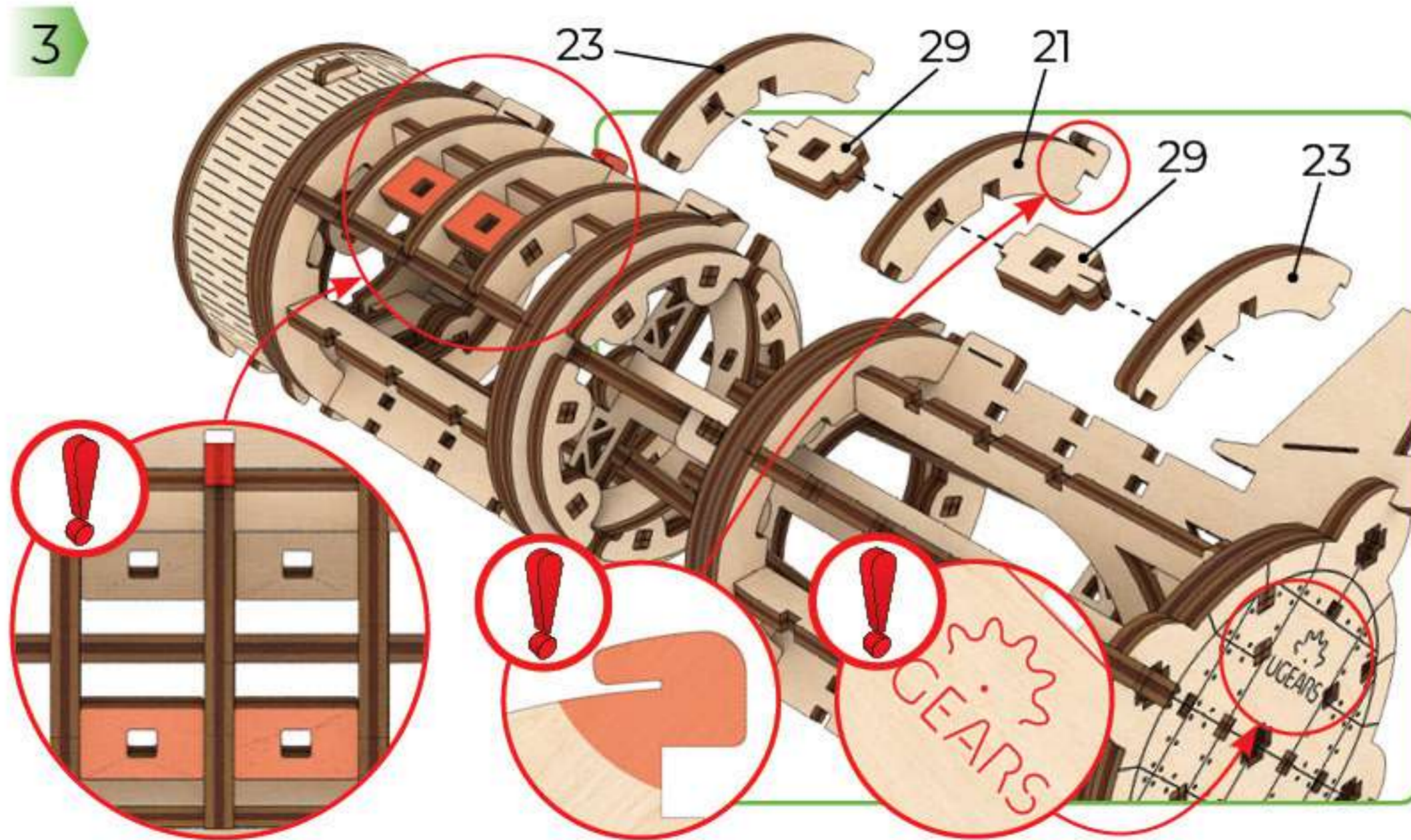
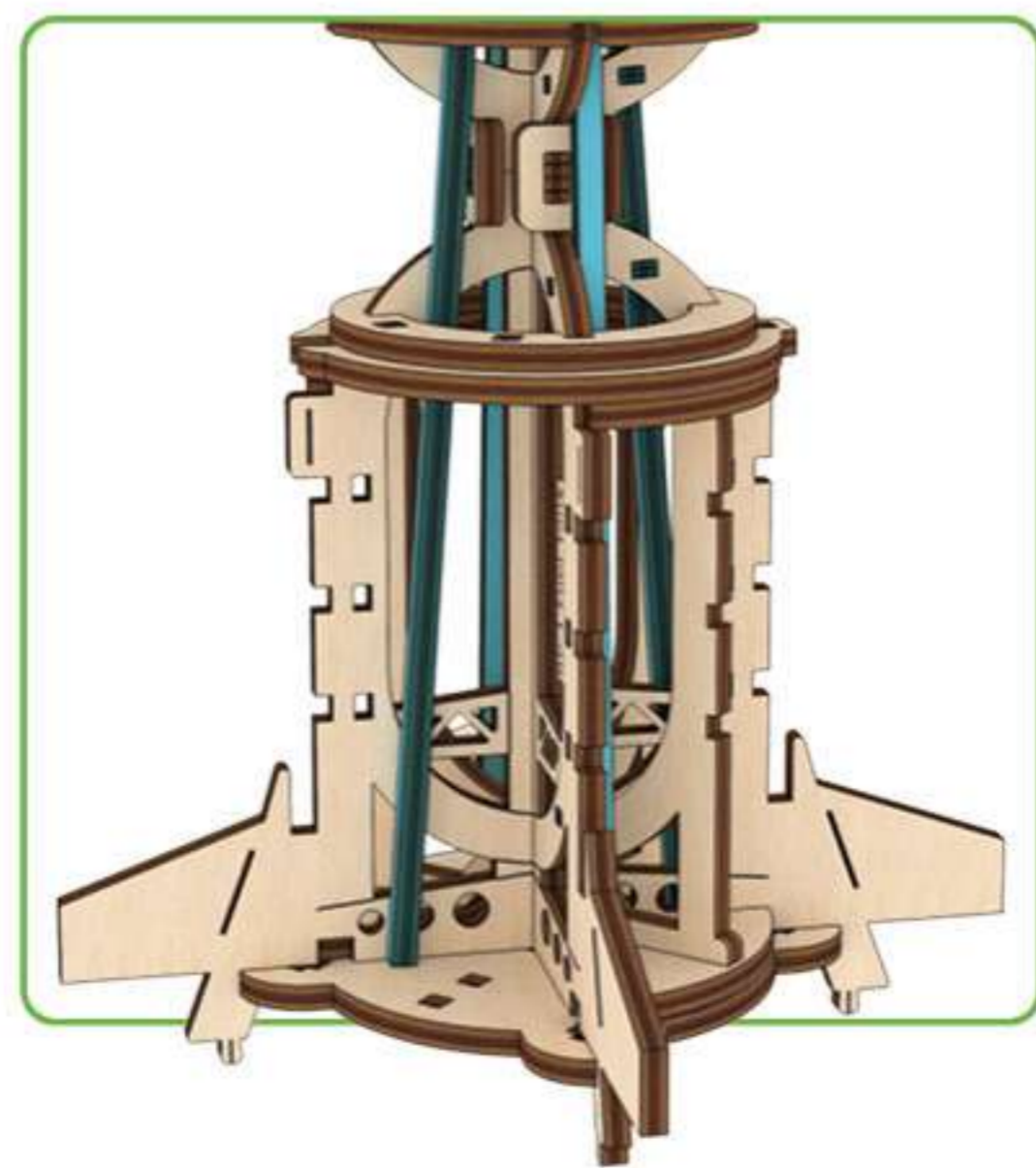
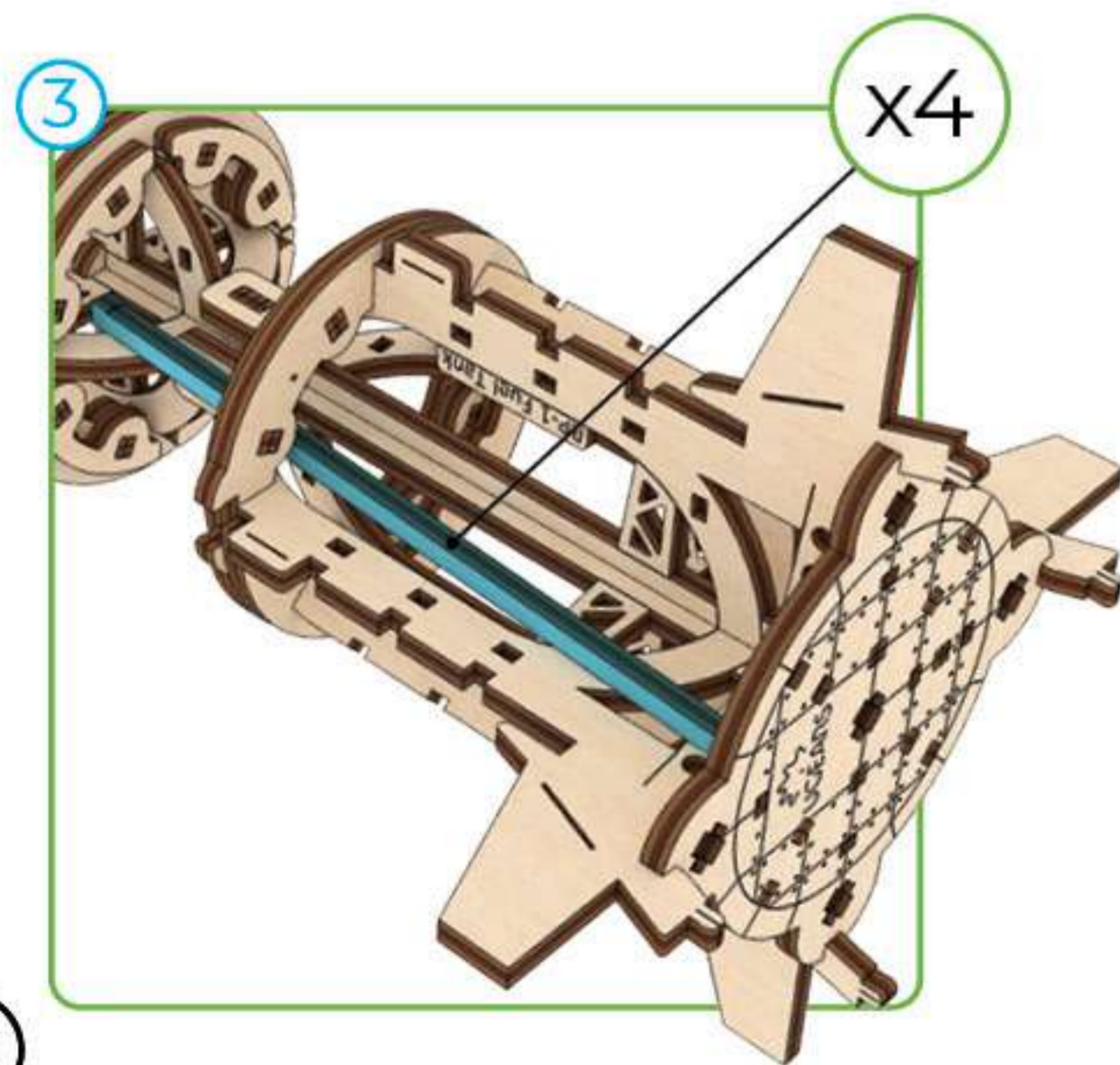
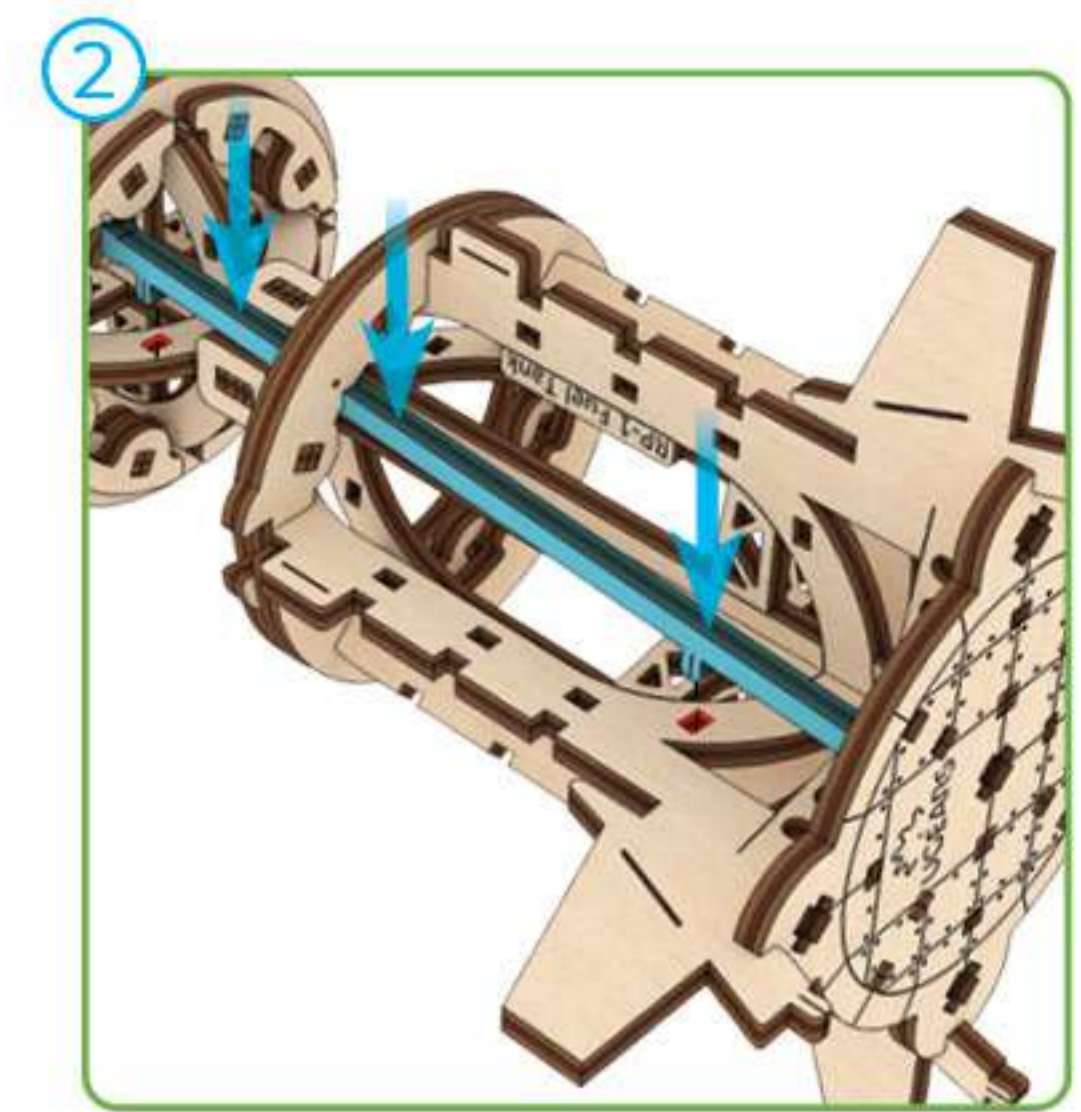
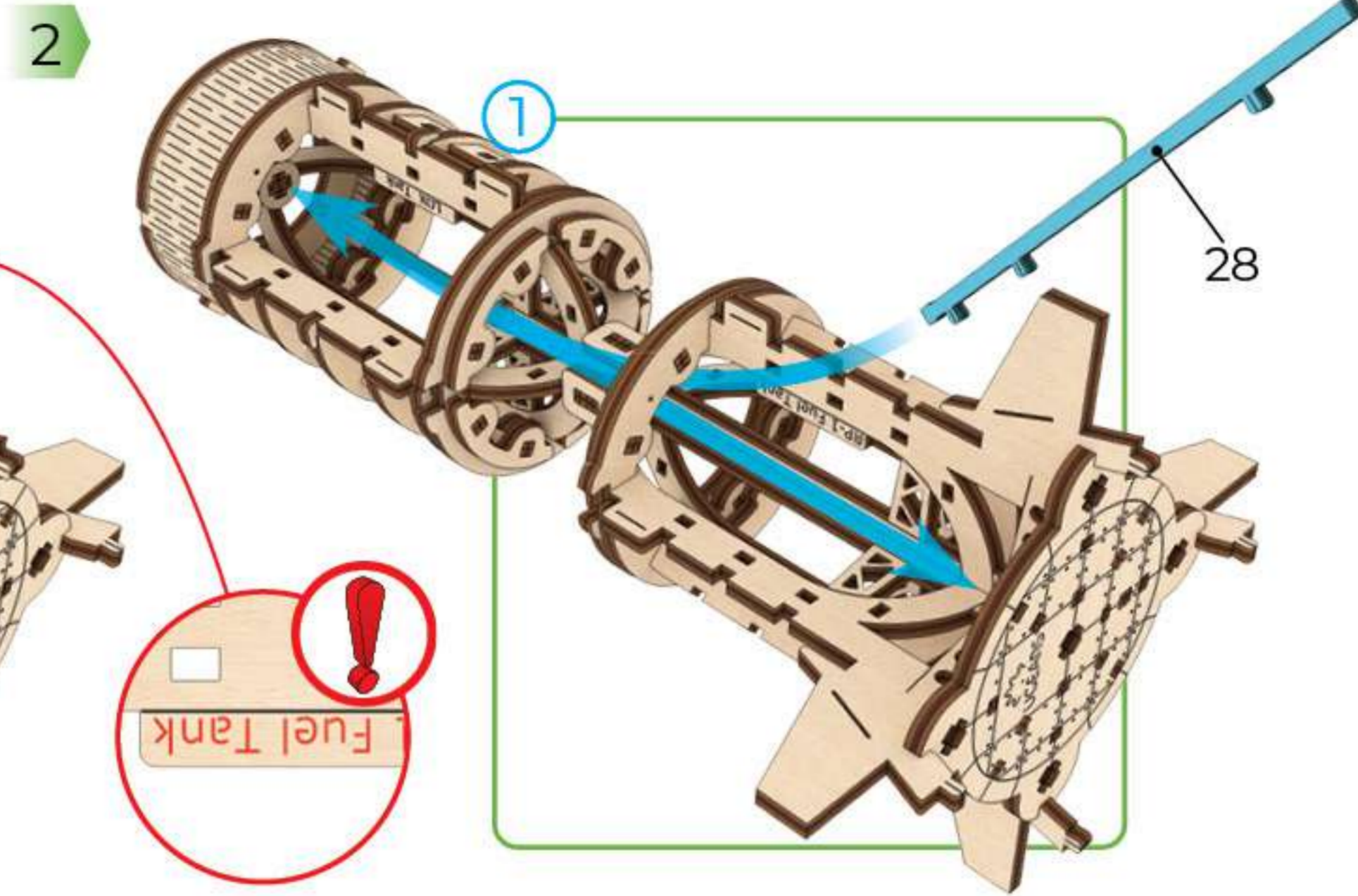
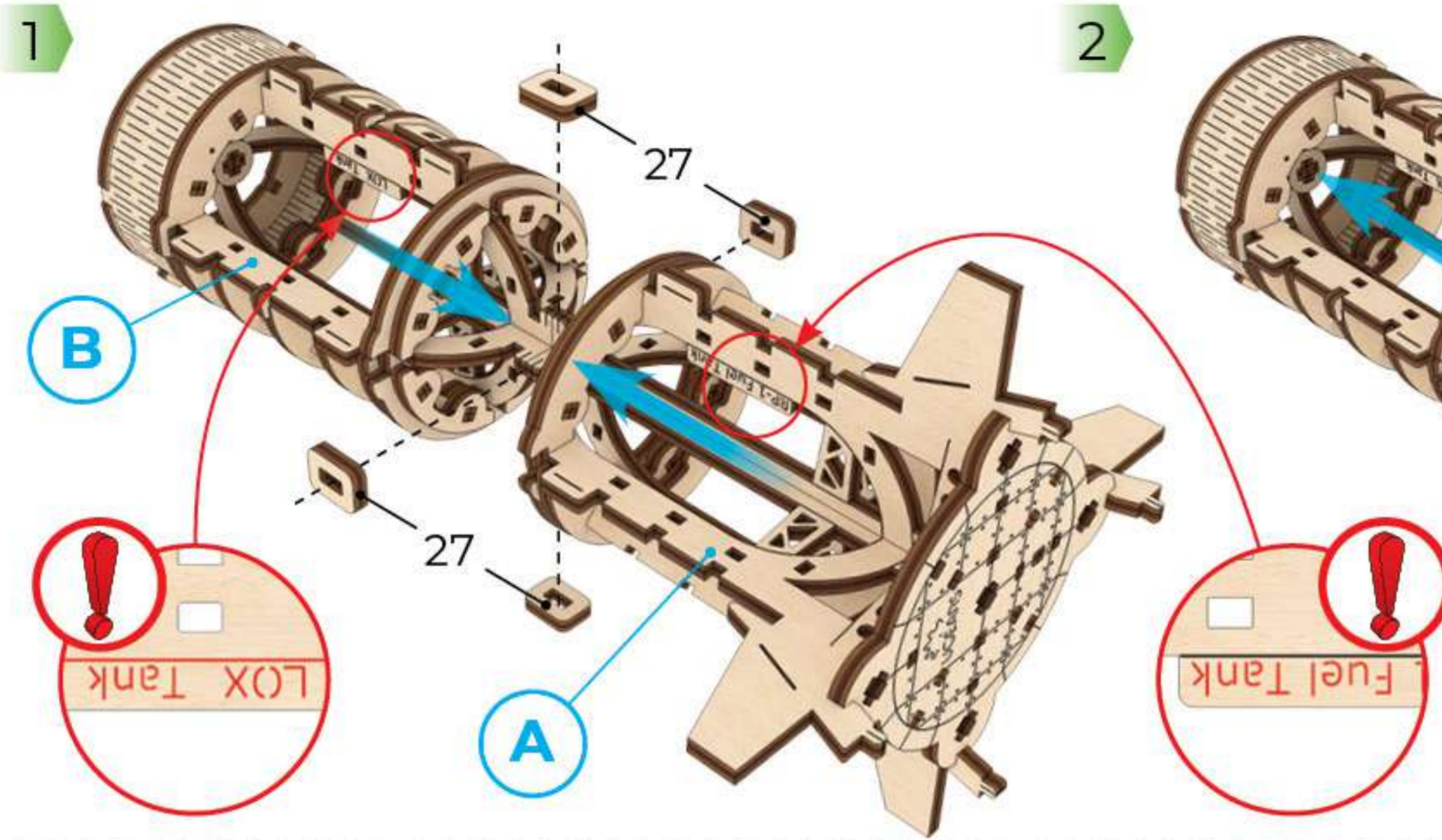
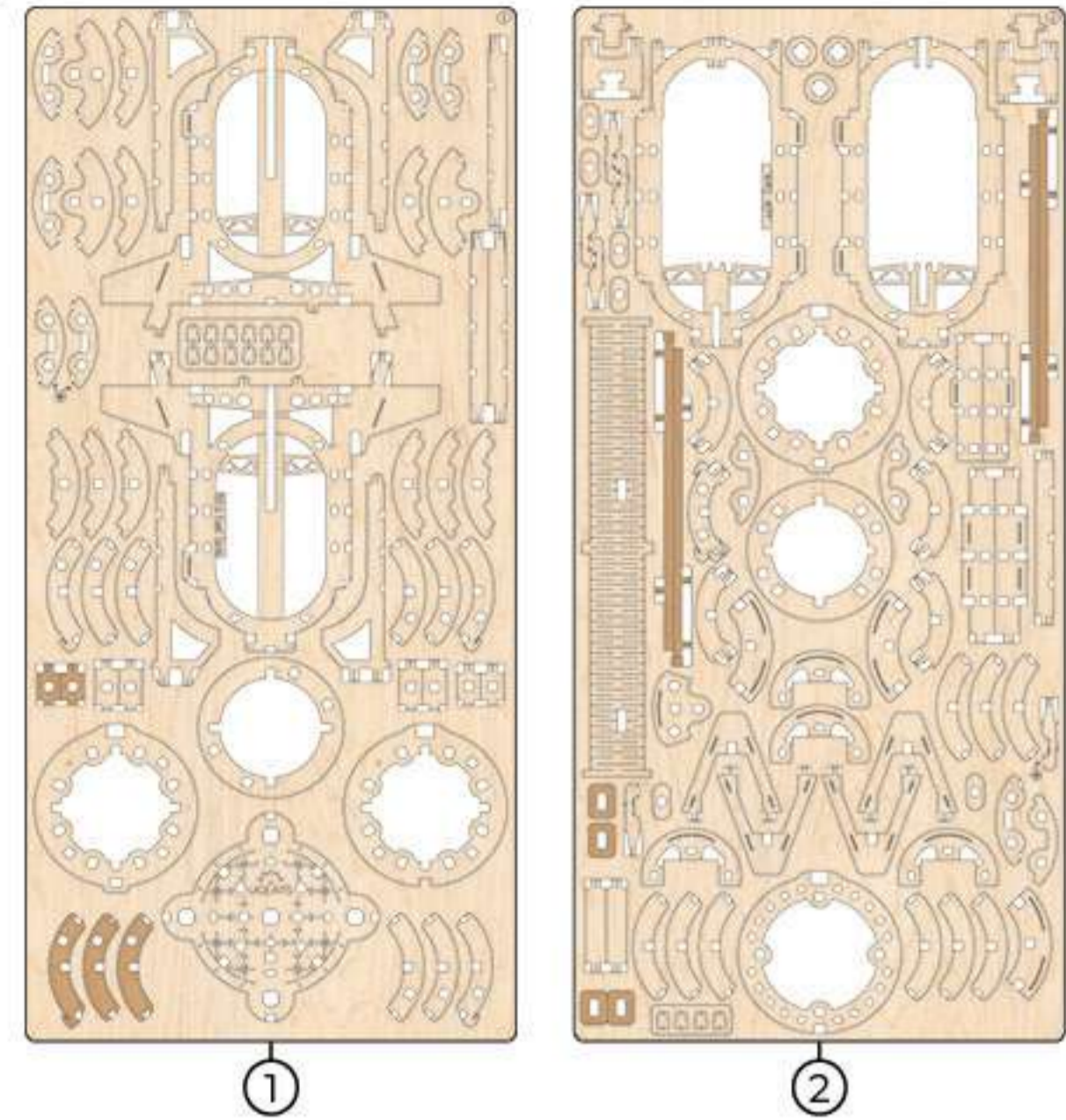

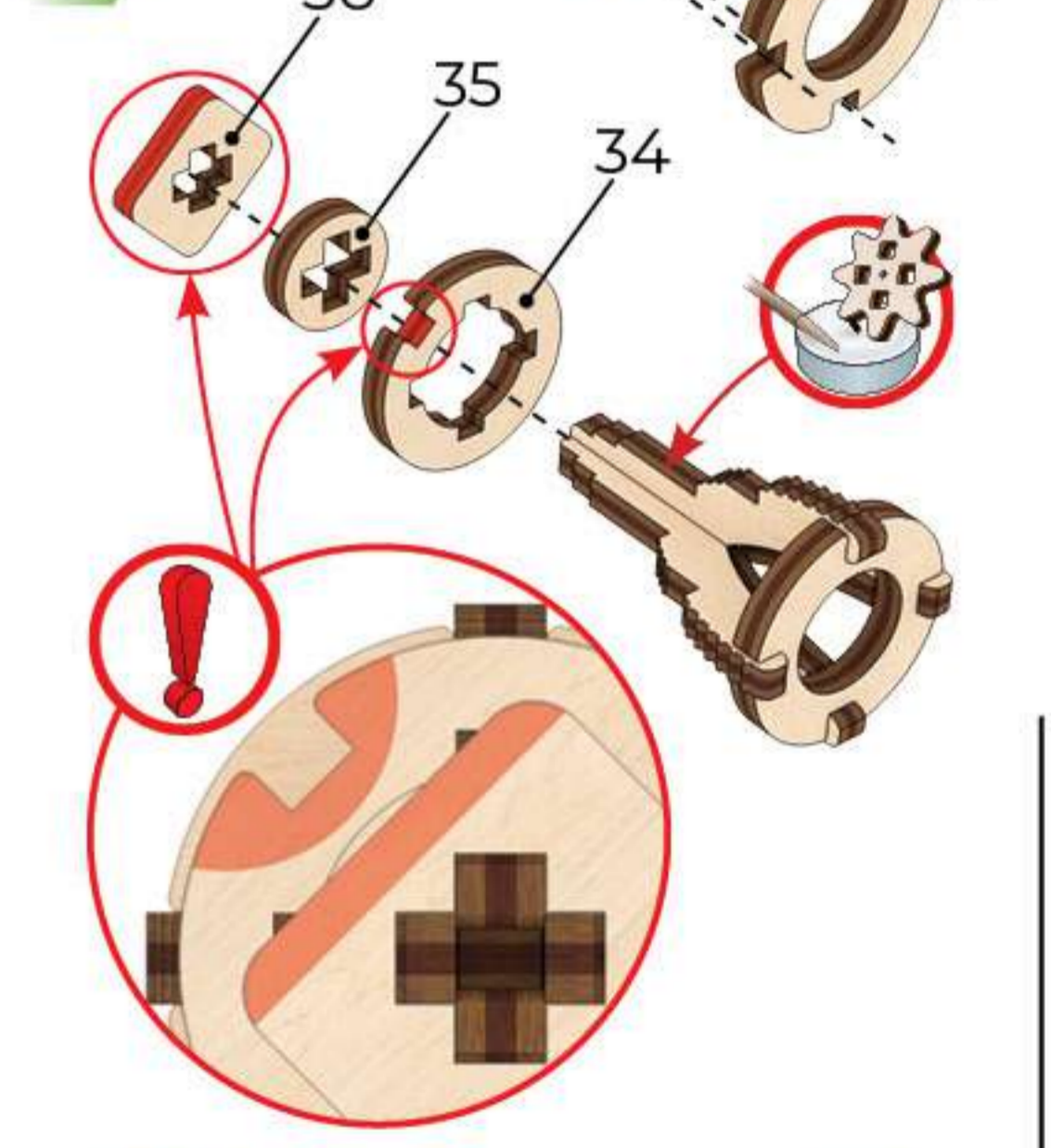
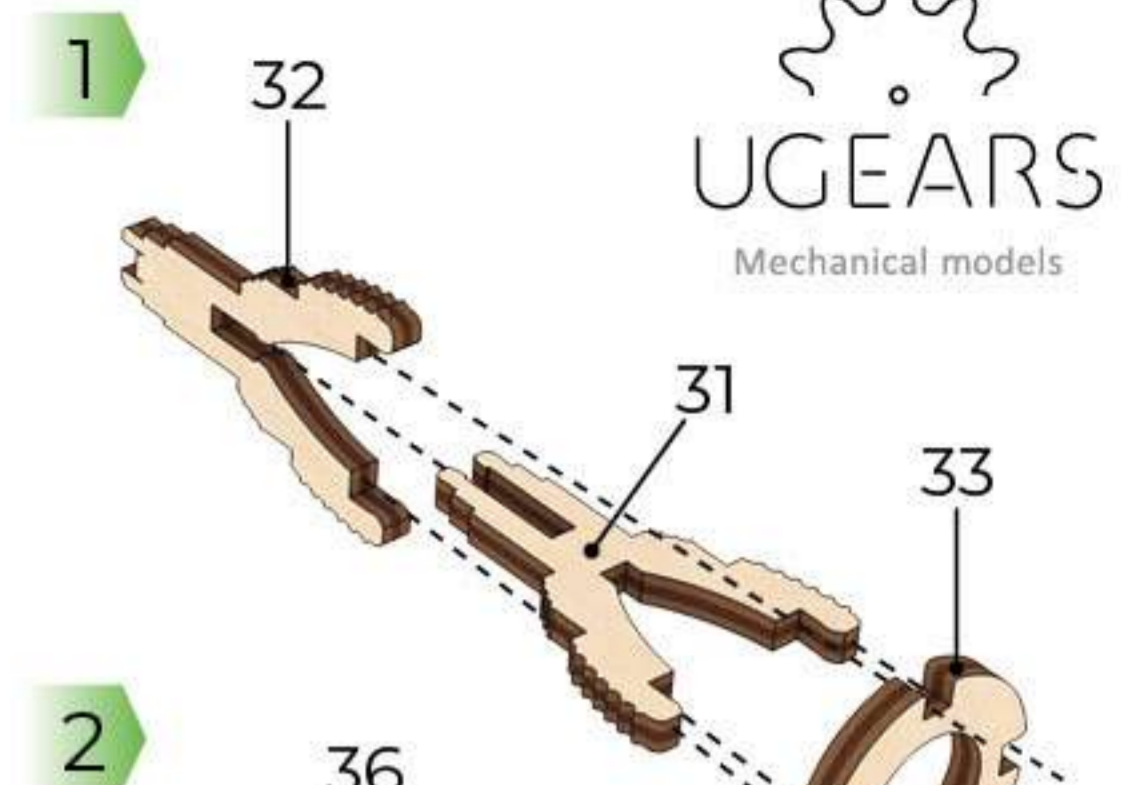
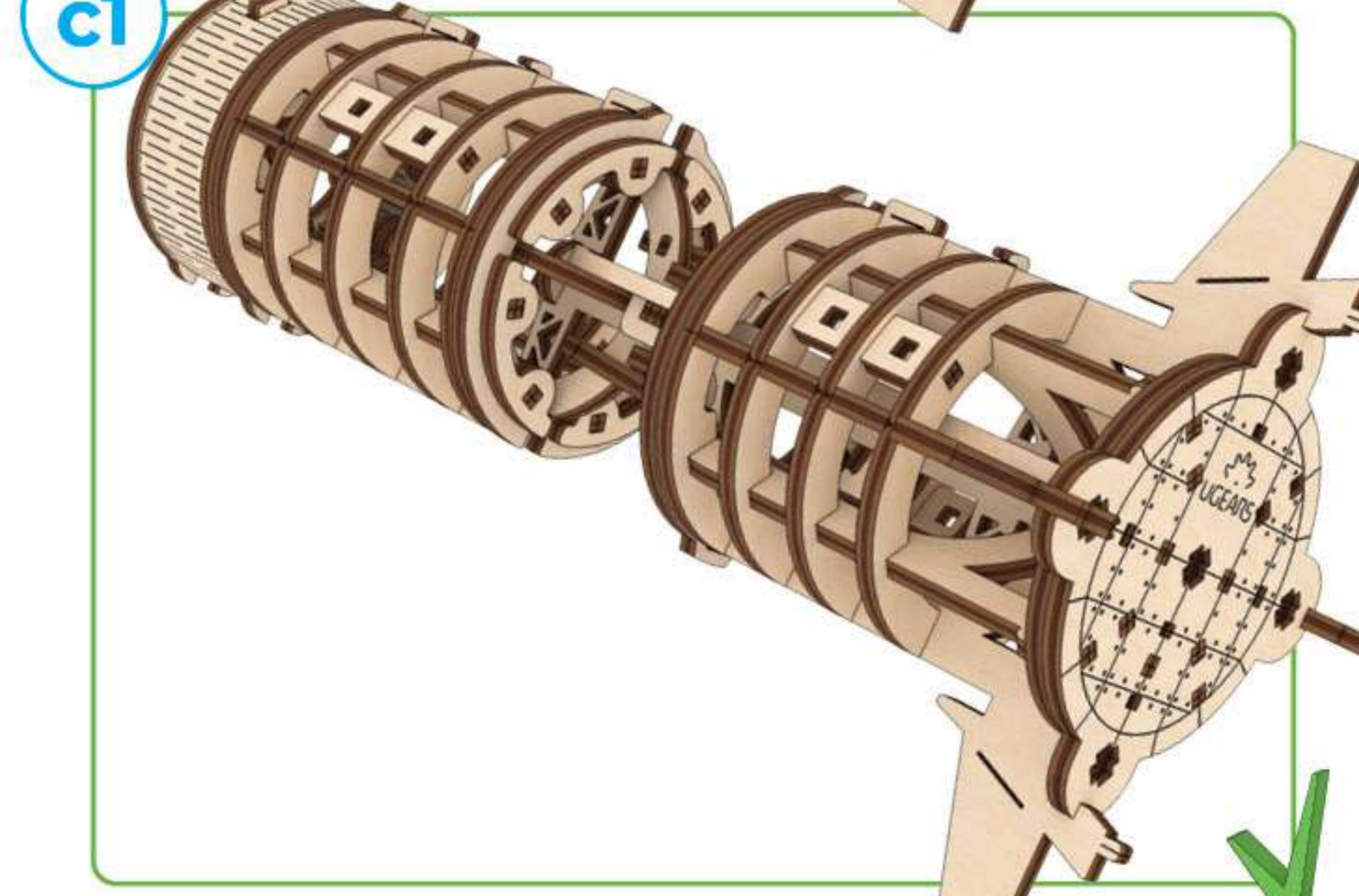
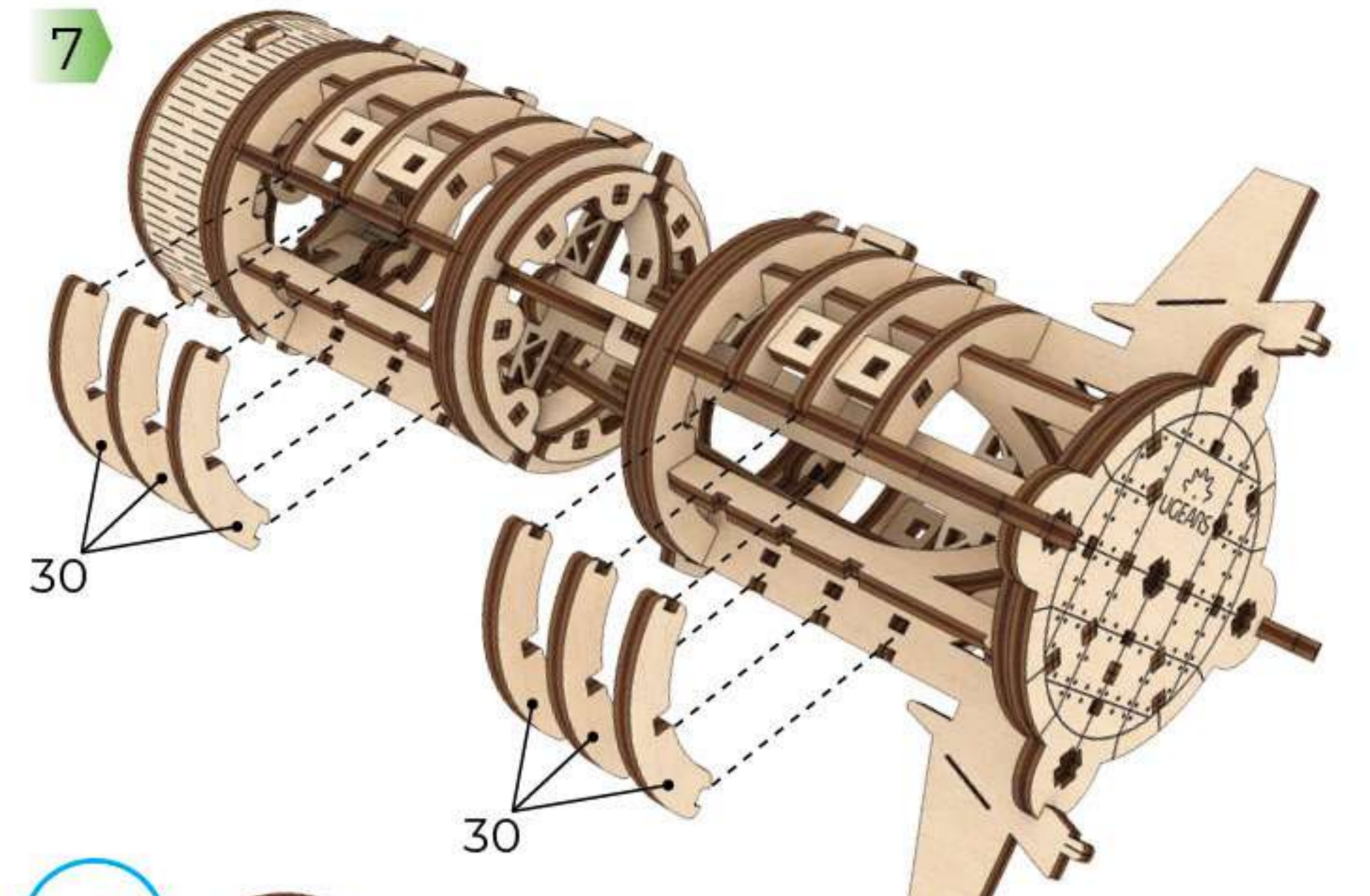
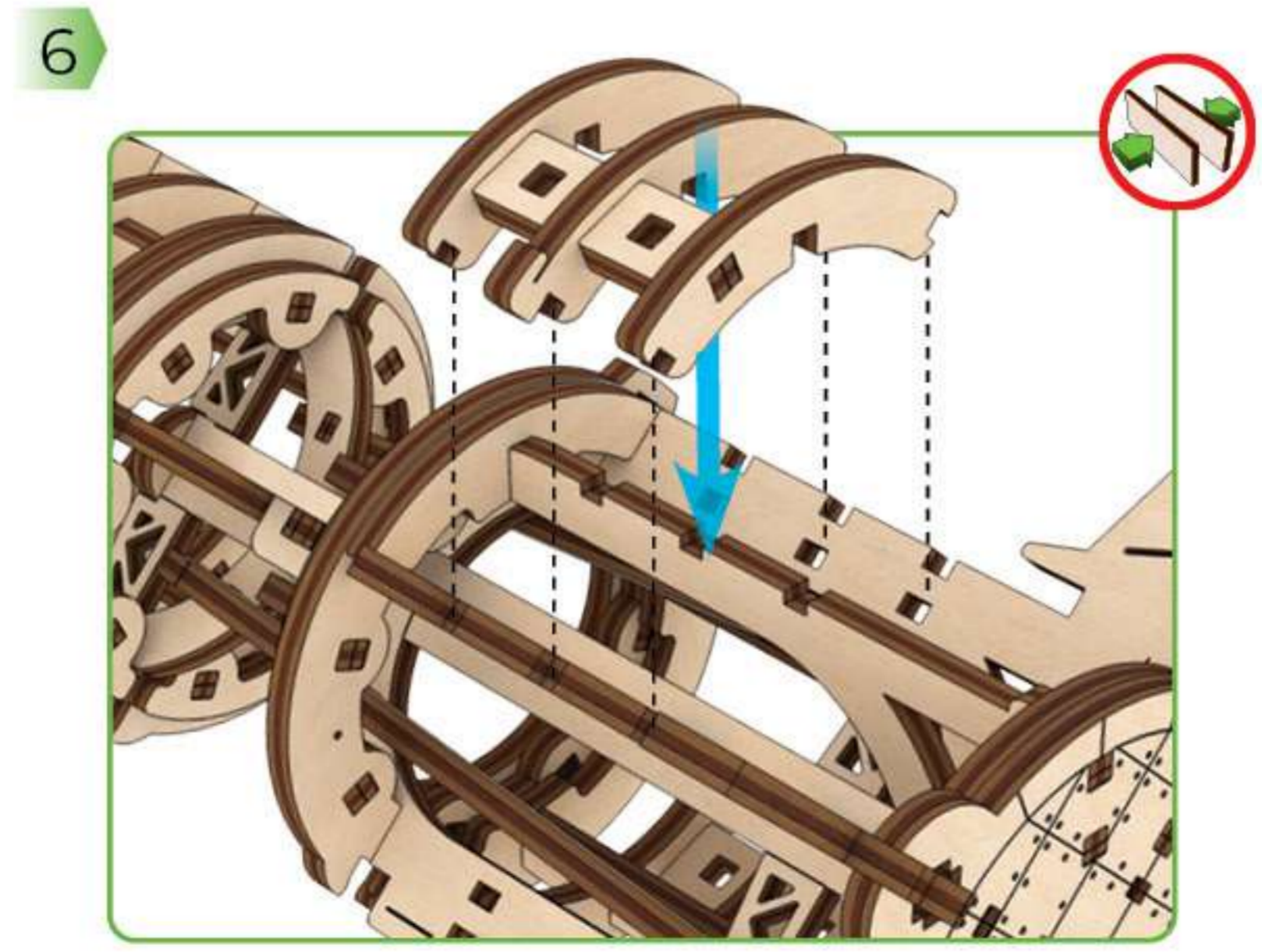
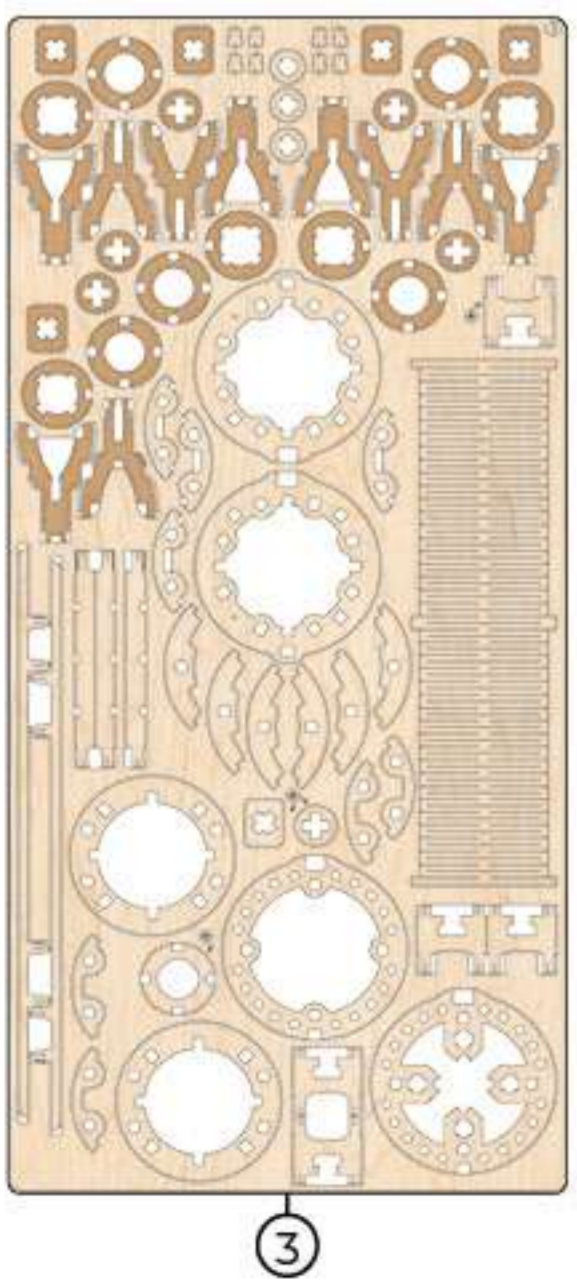
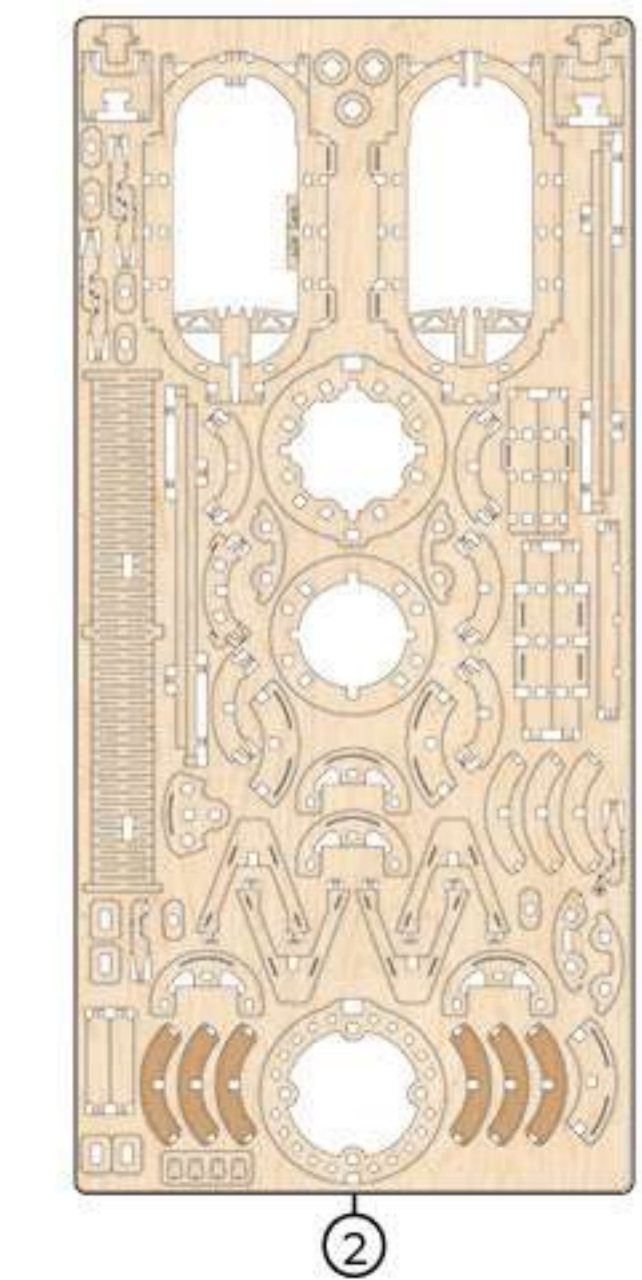
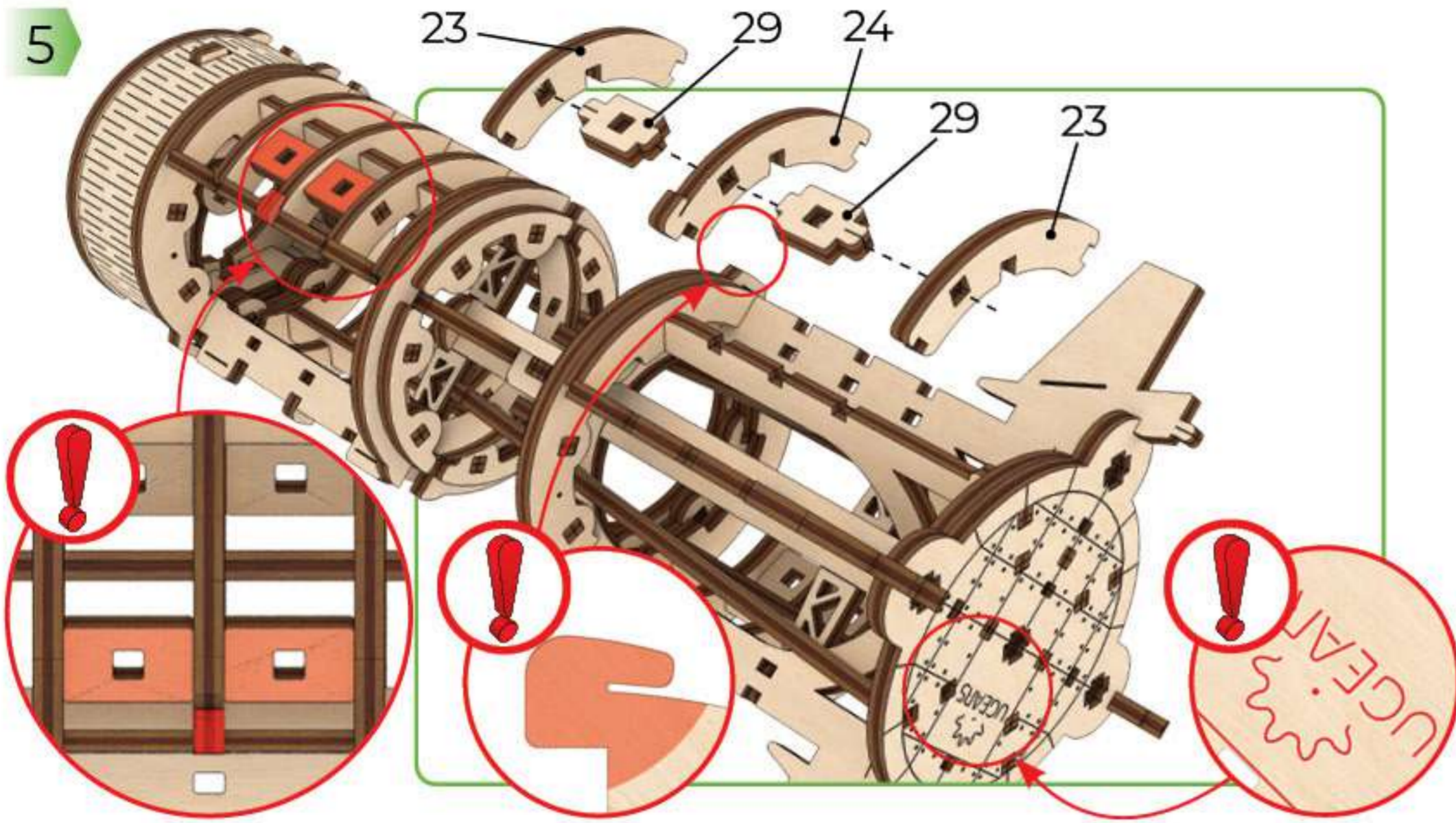
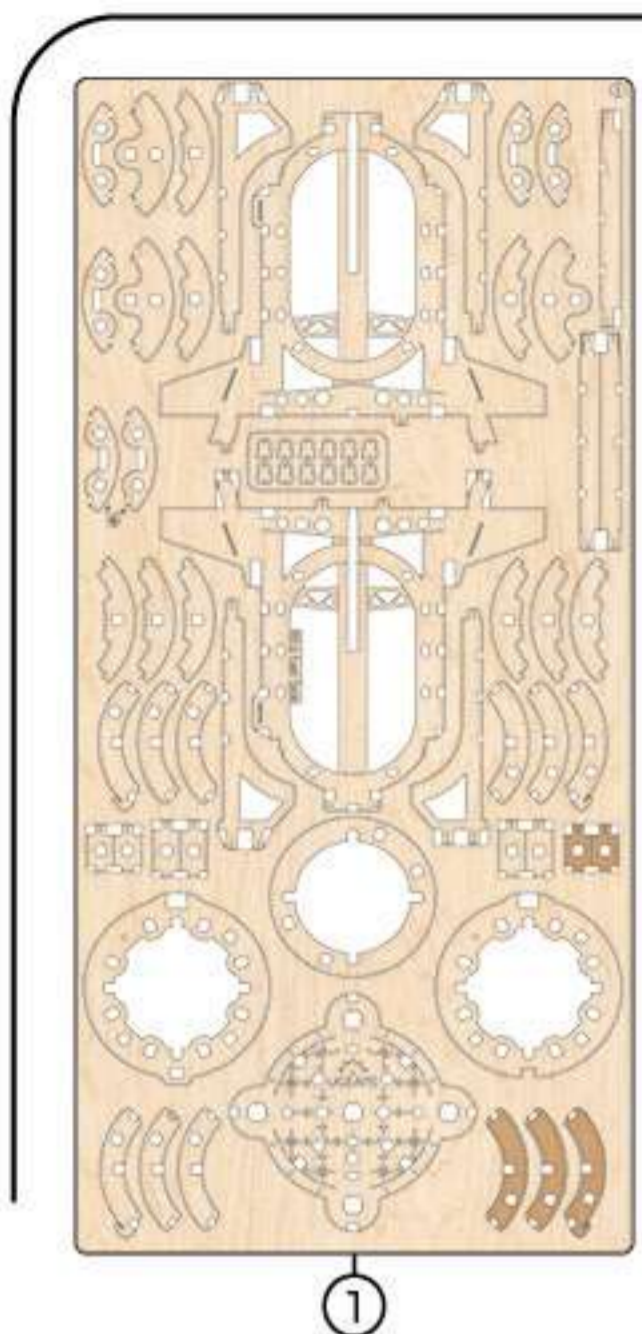

Mechanical models

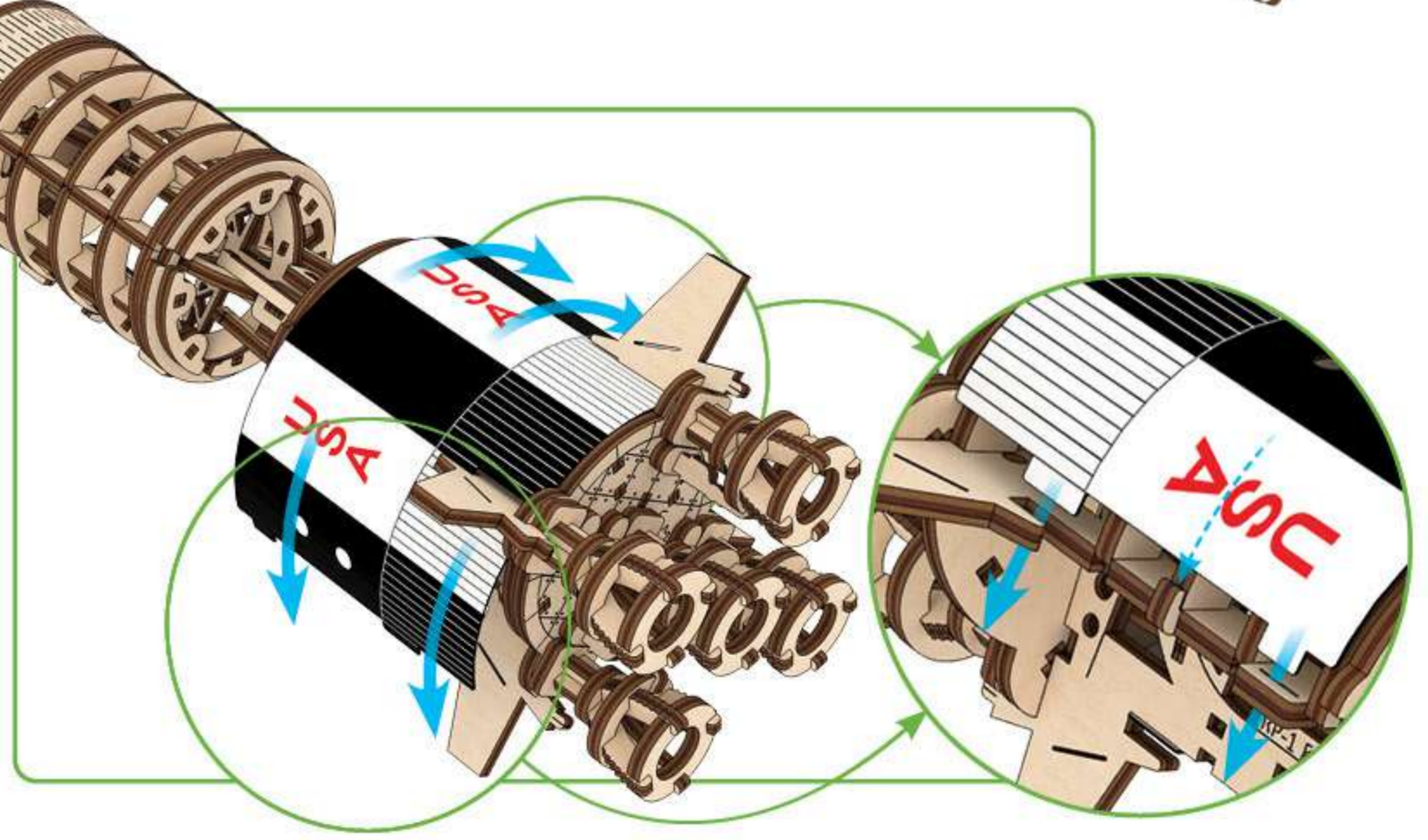
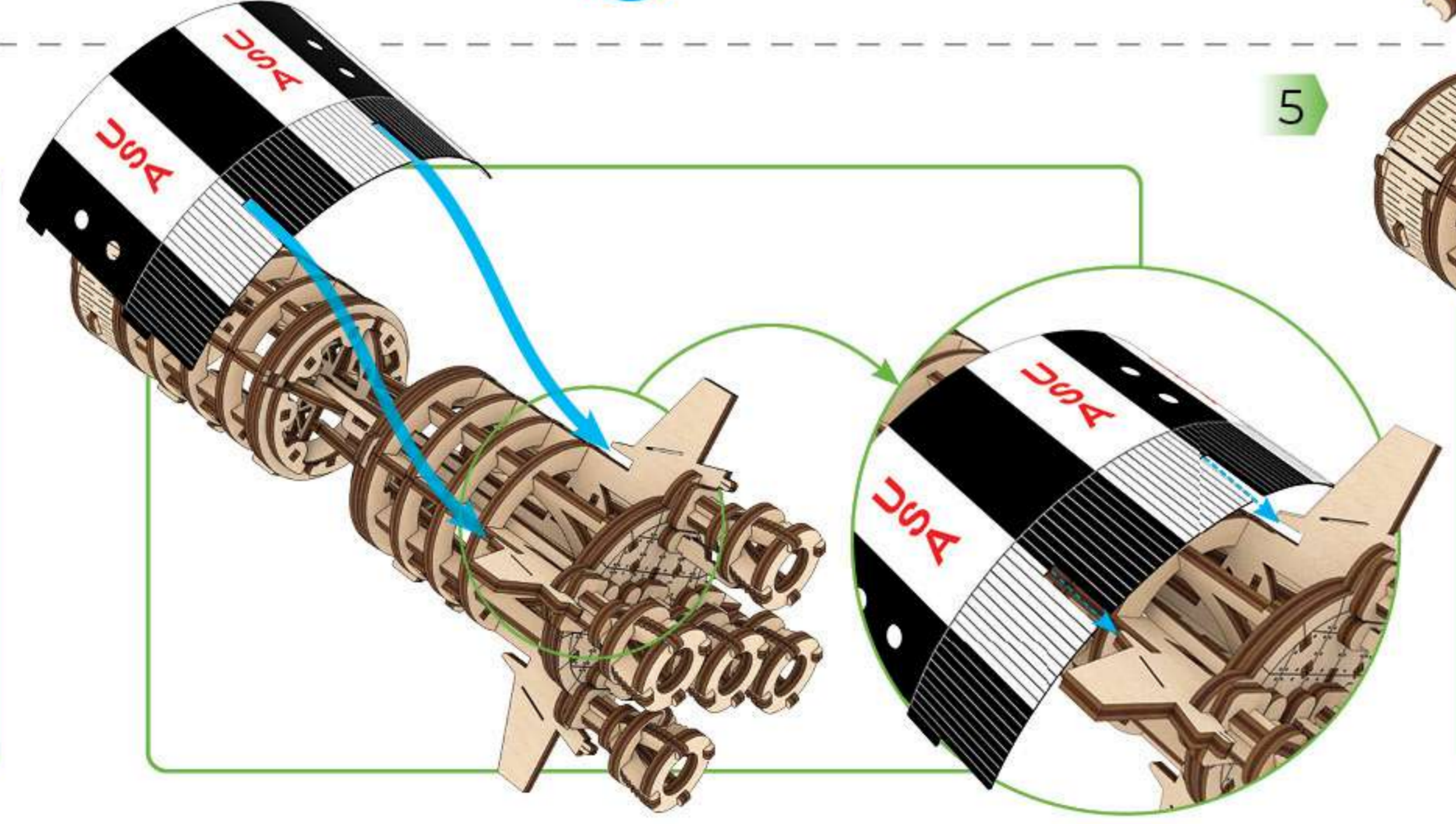
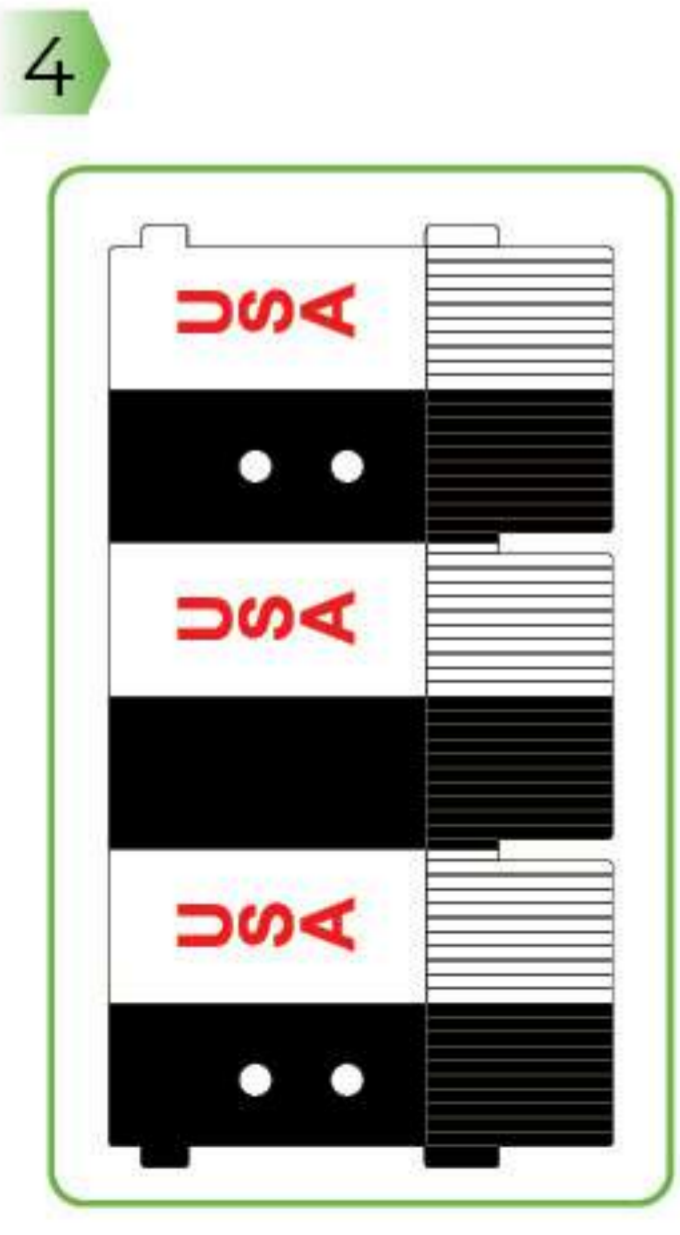
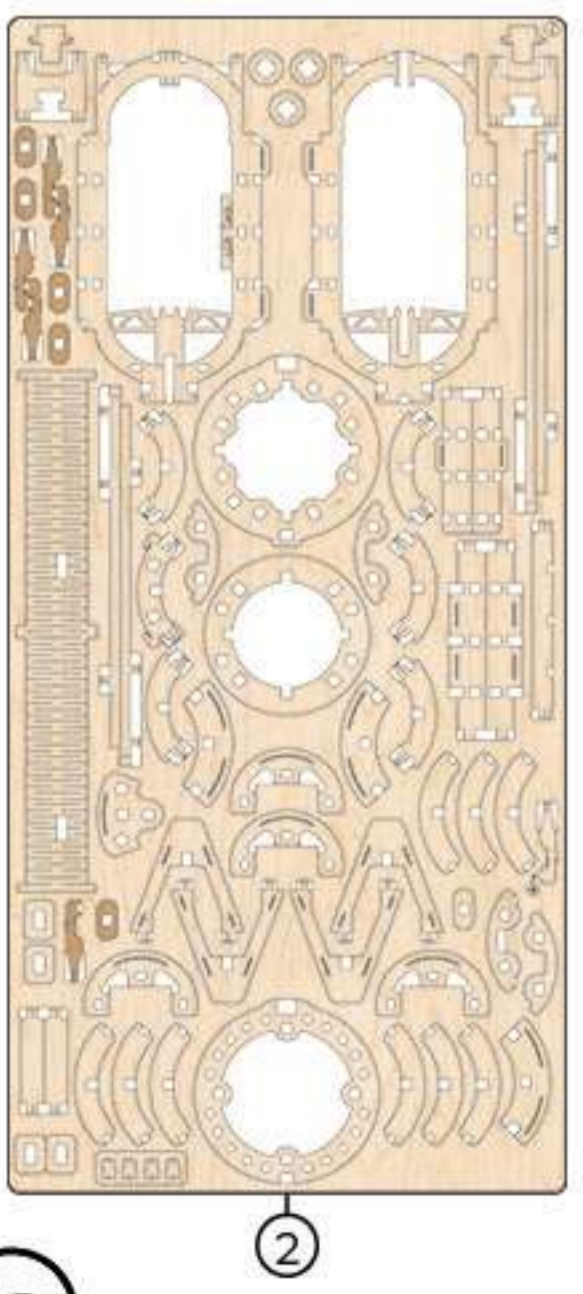
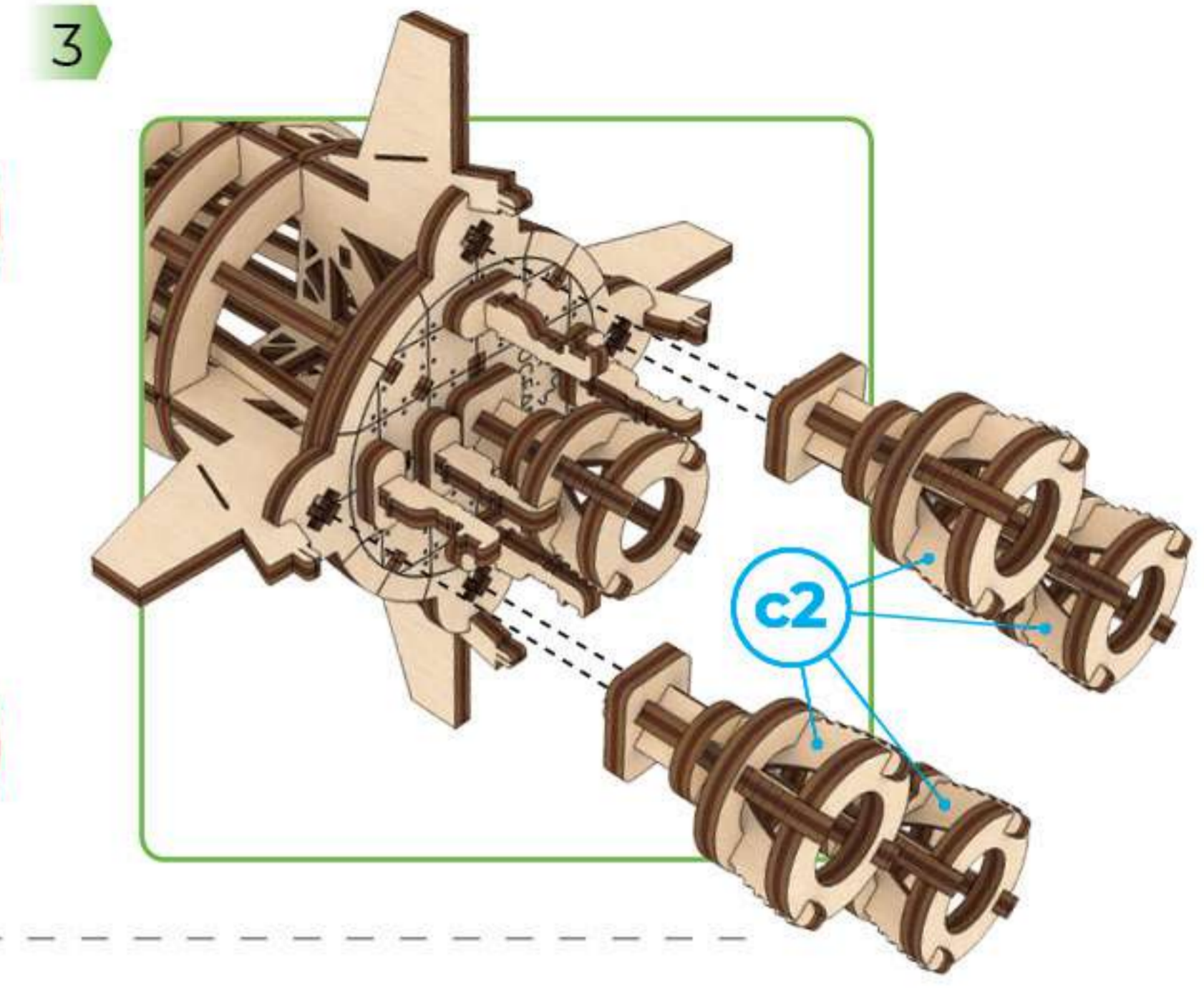
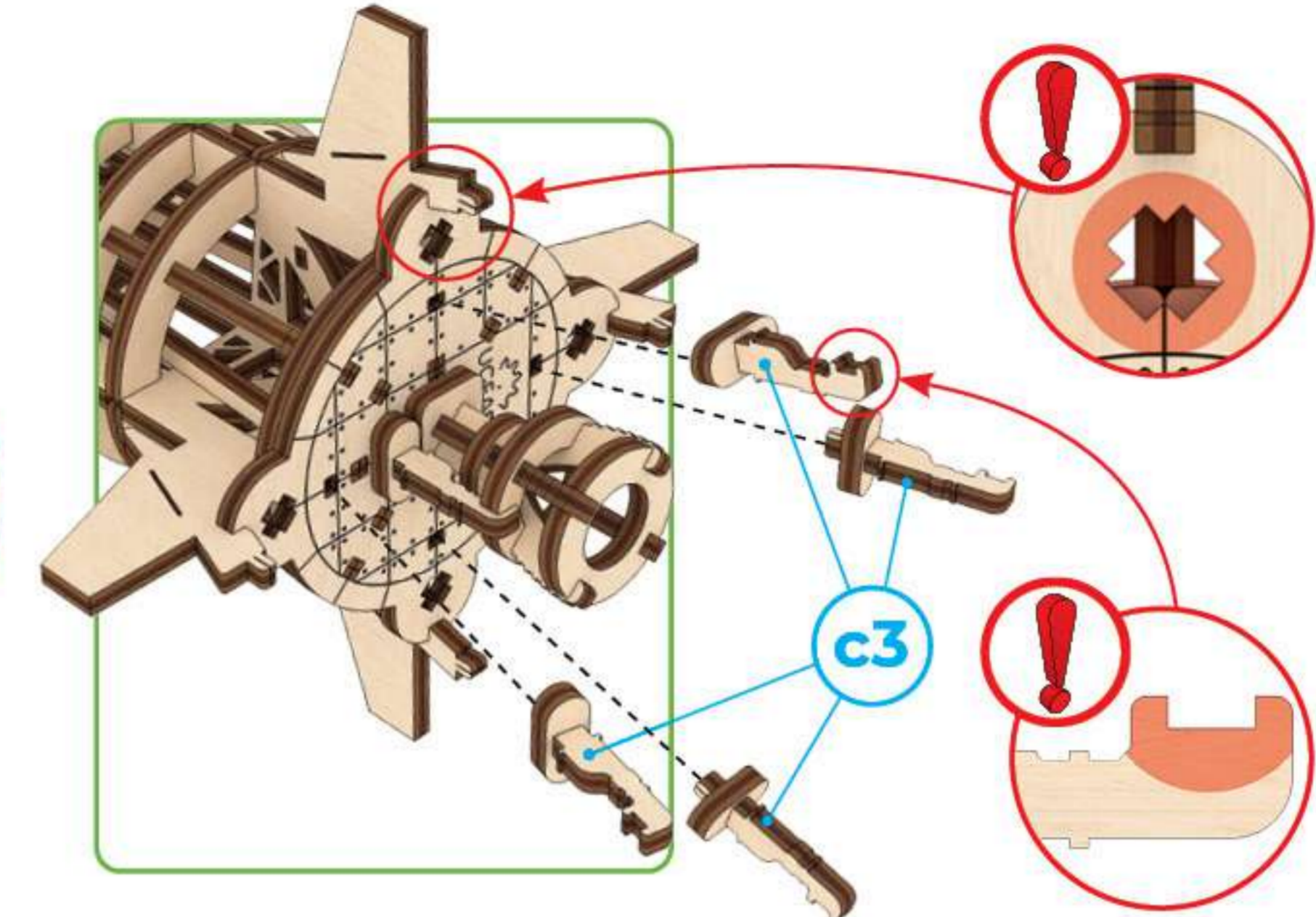
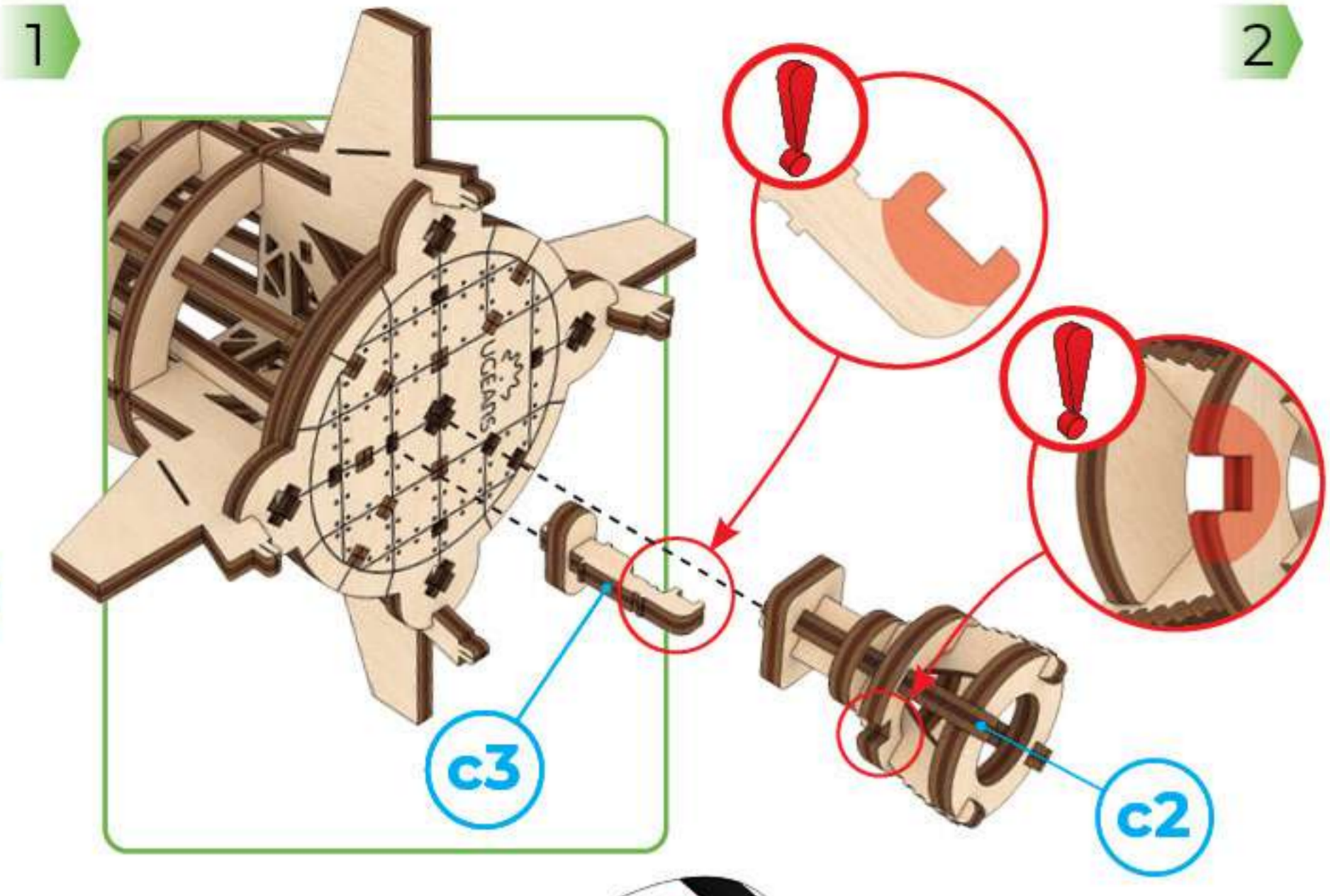
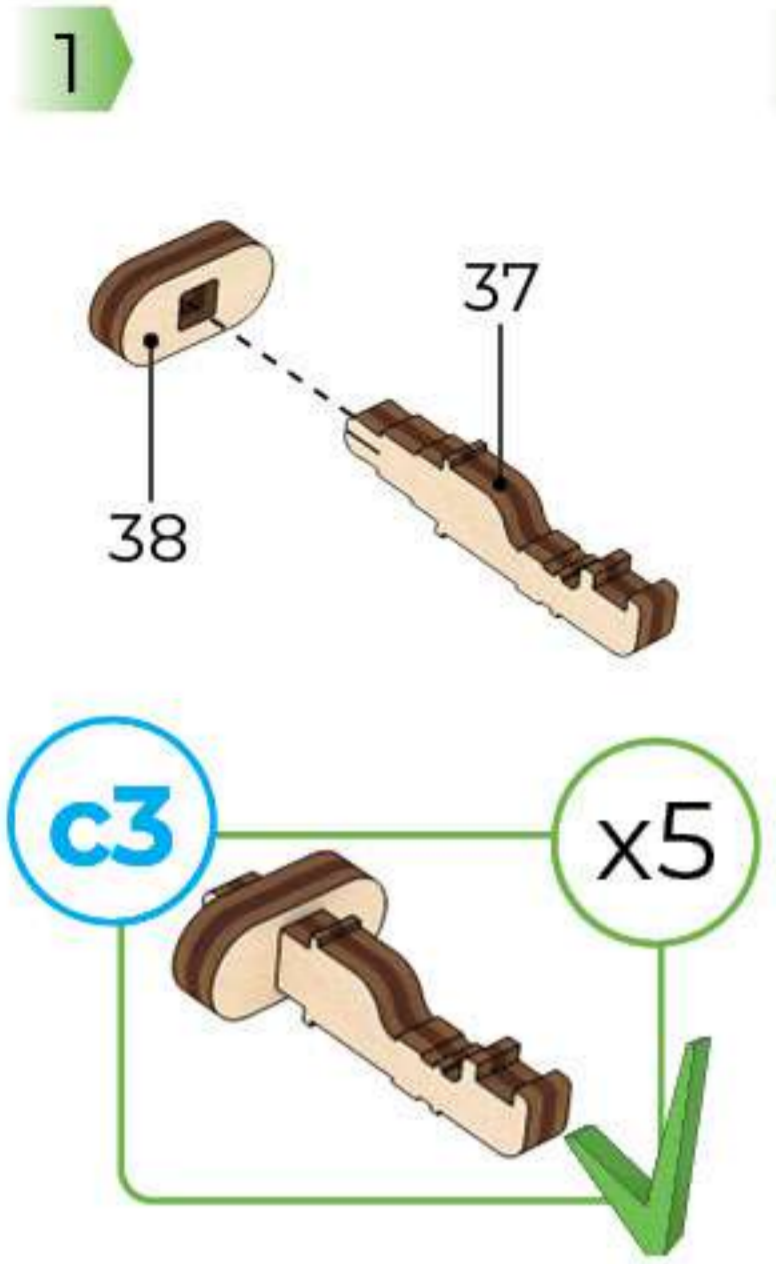

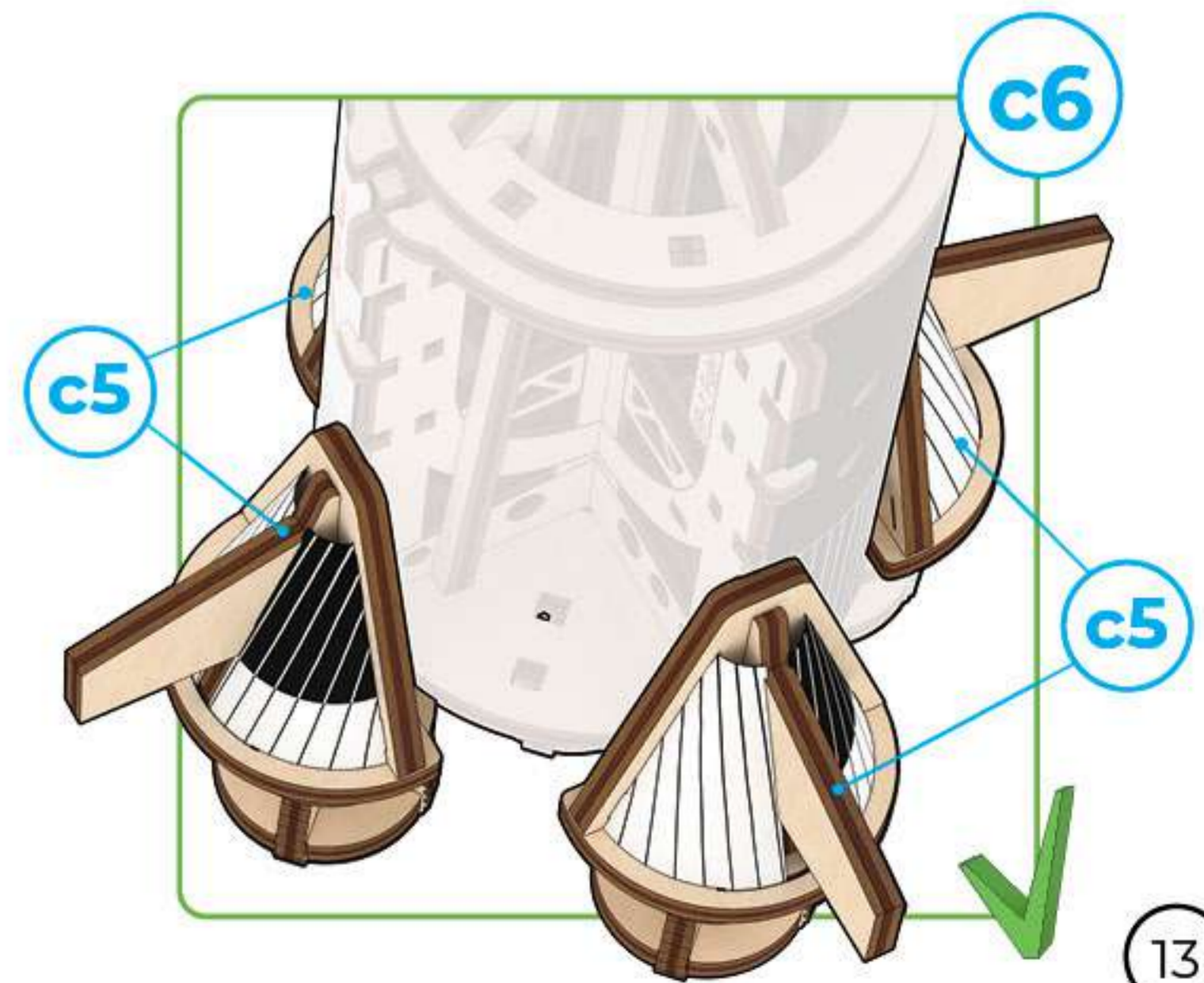
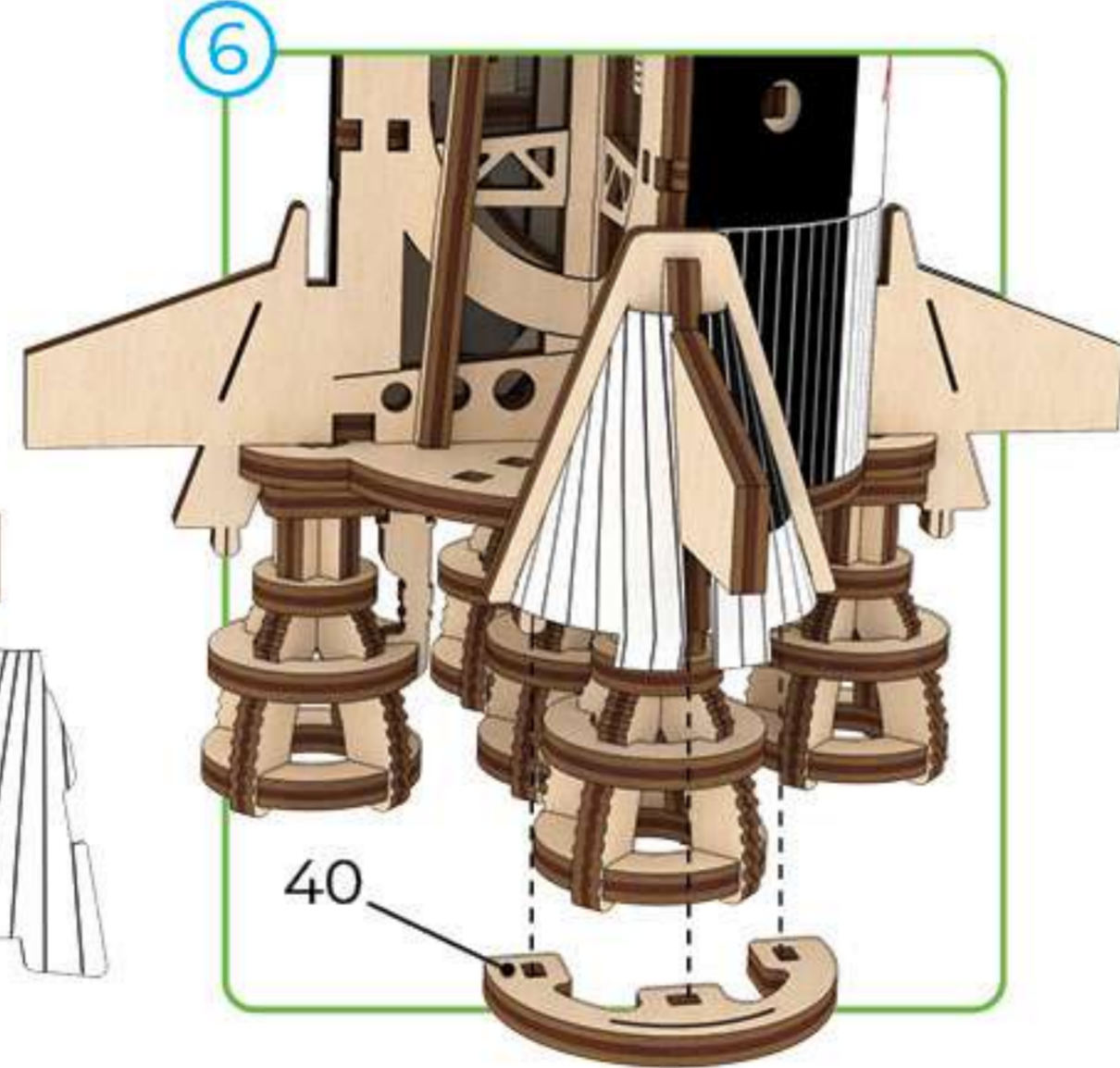
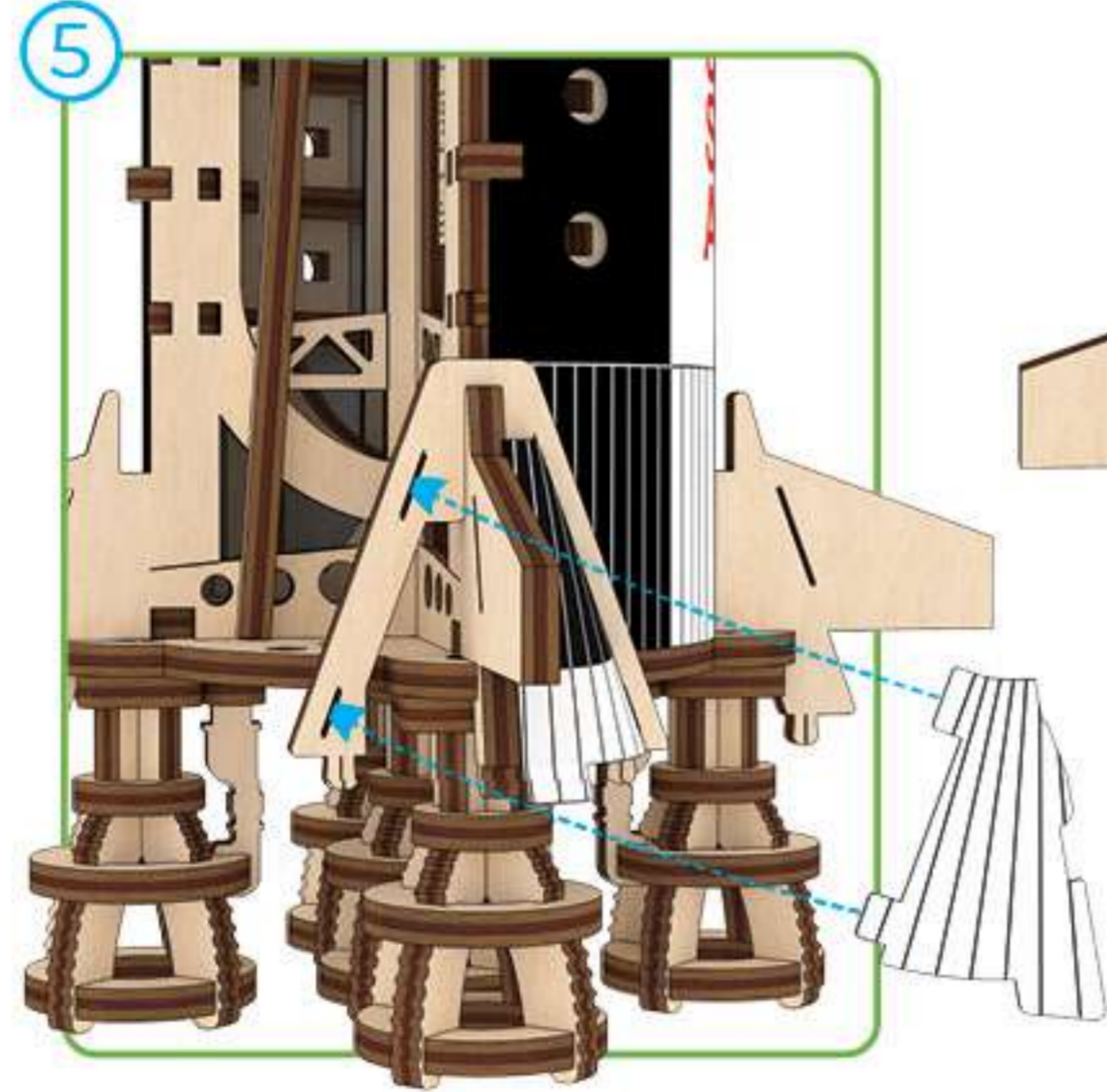
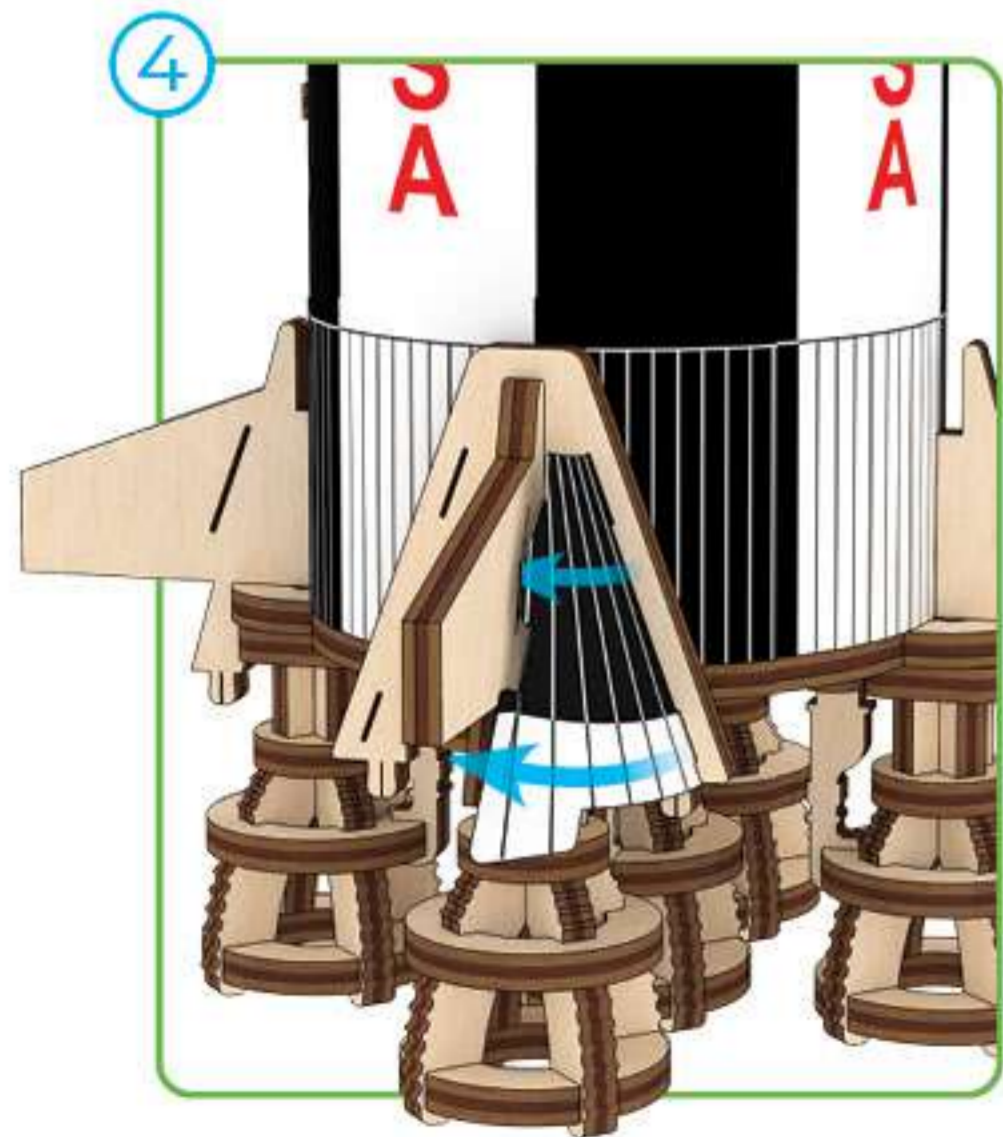
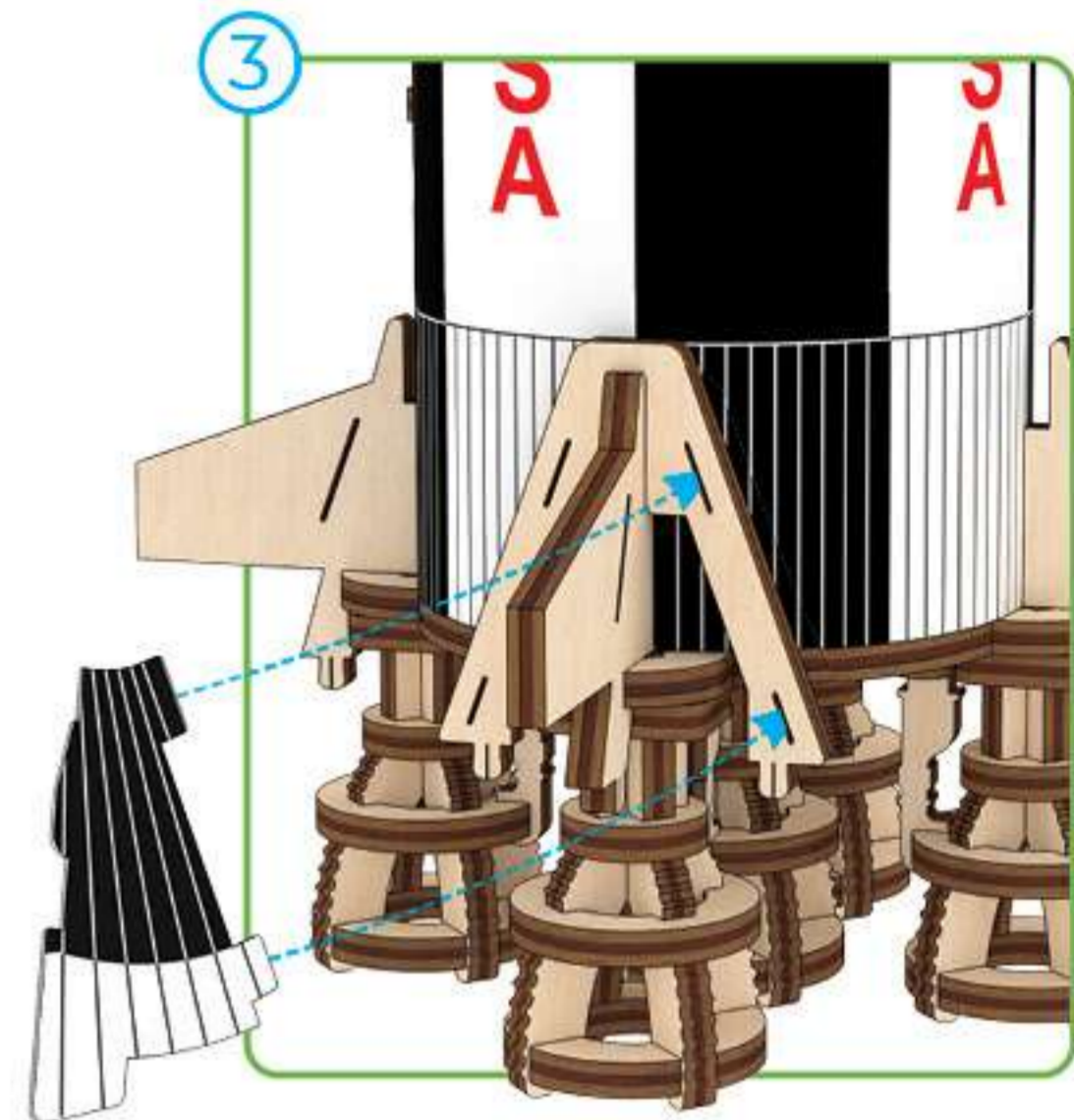
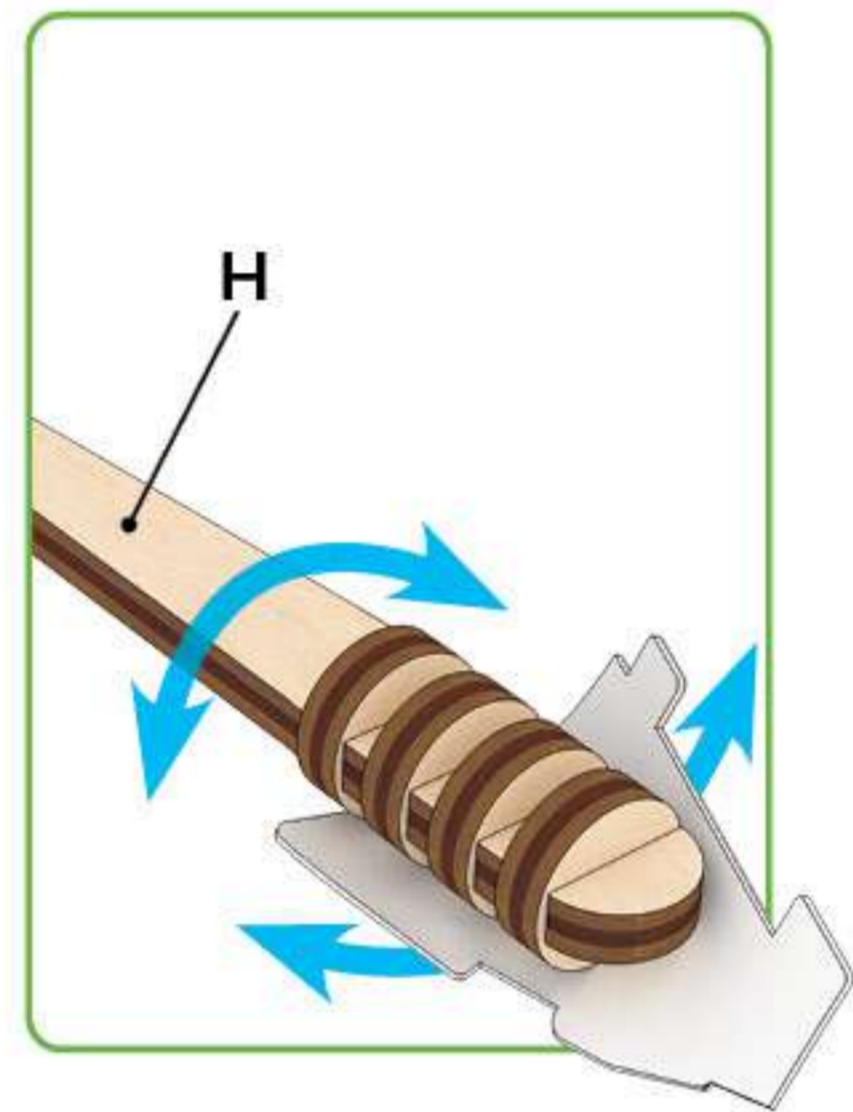
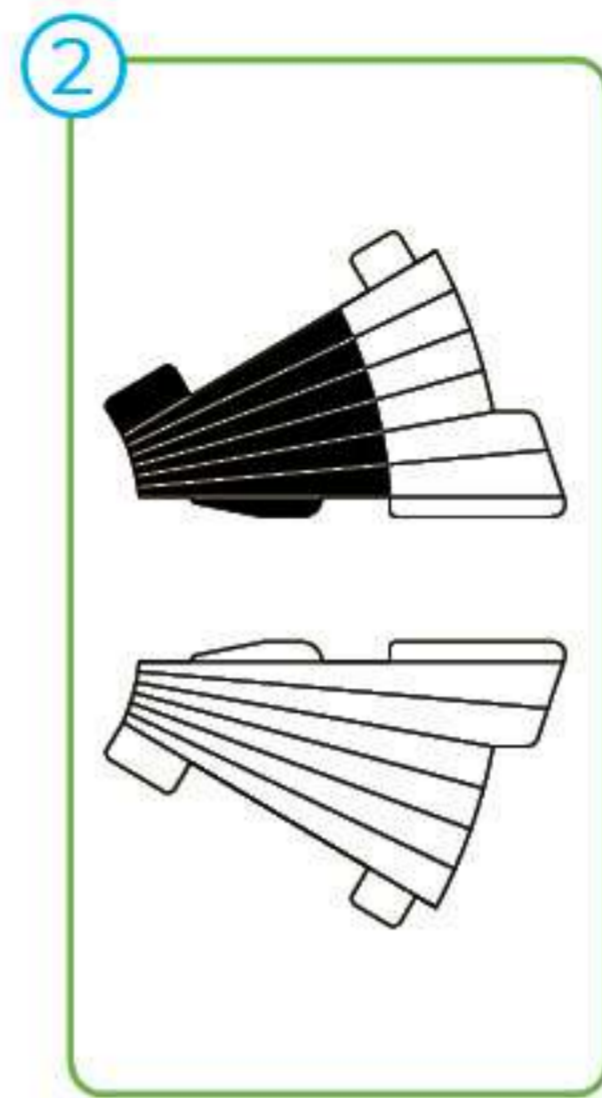
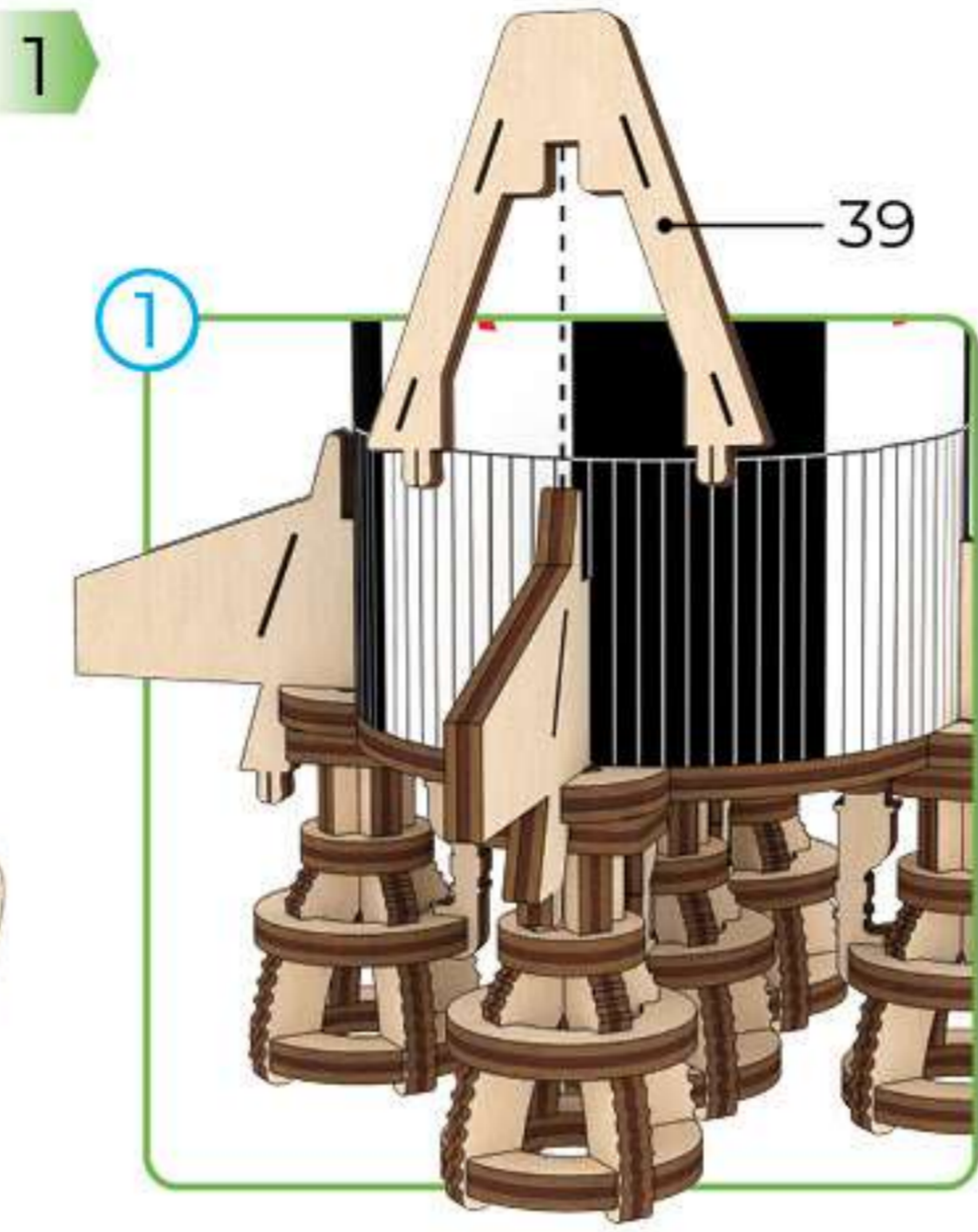
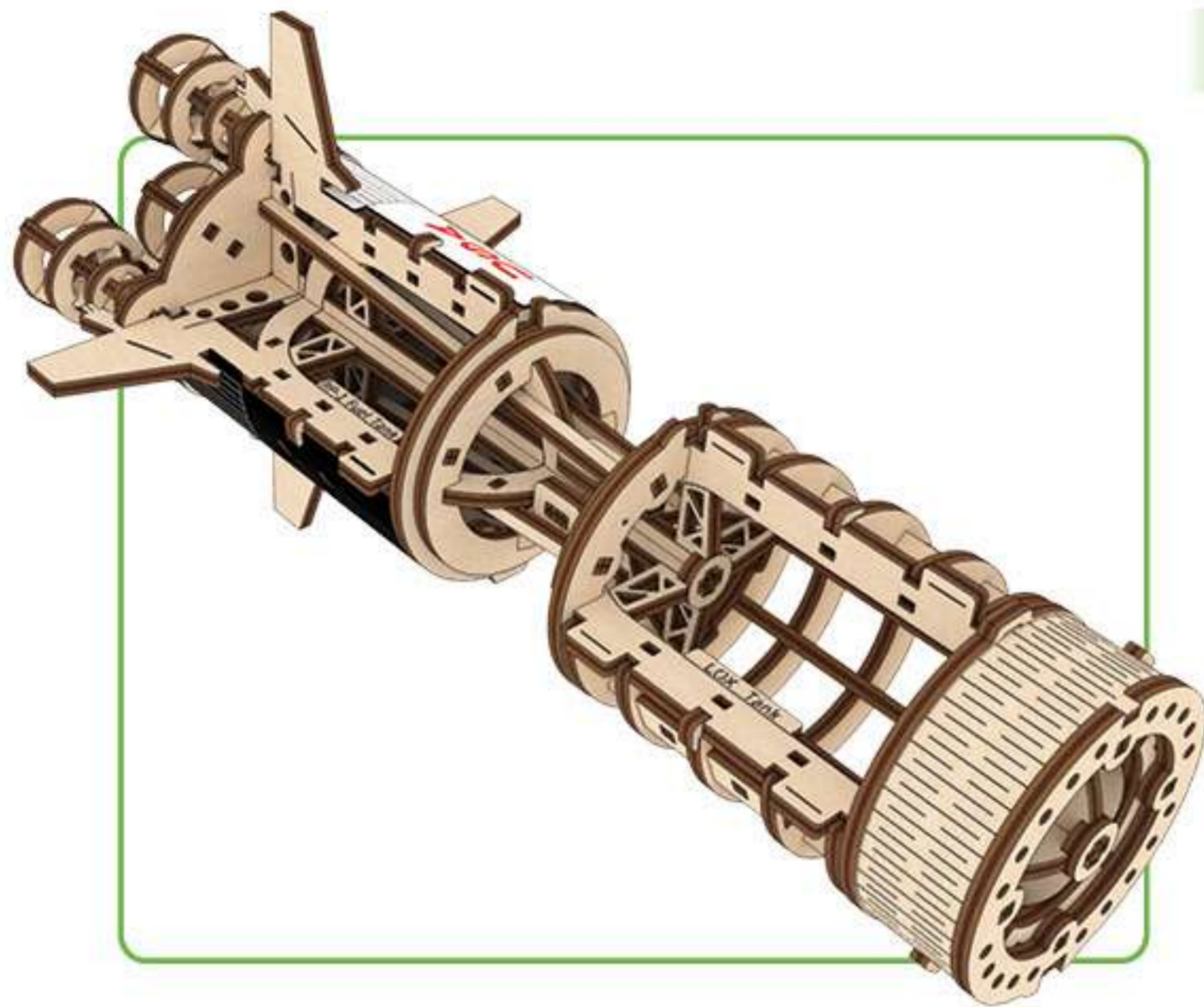
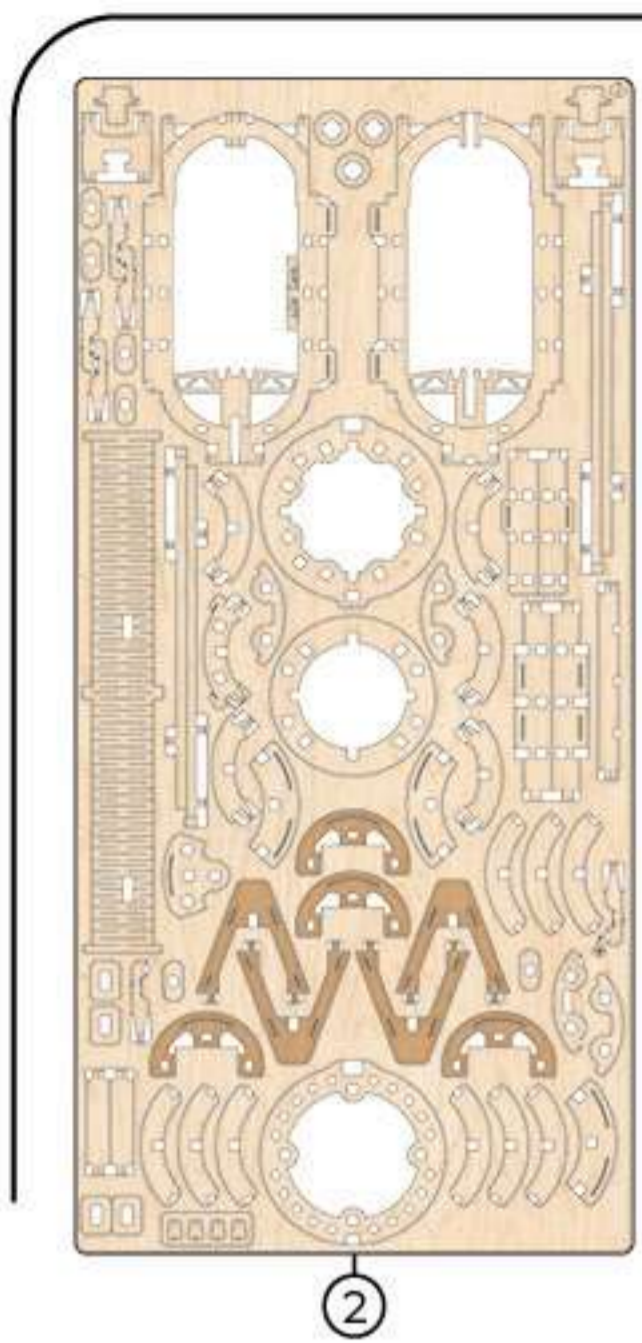

1

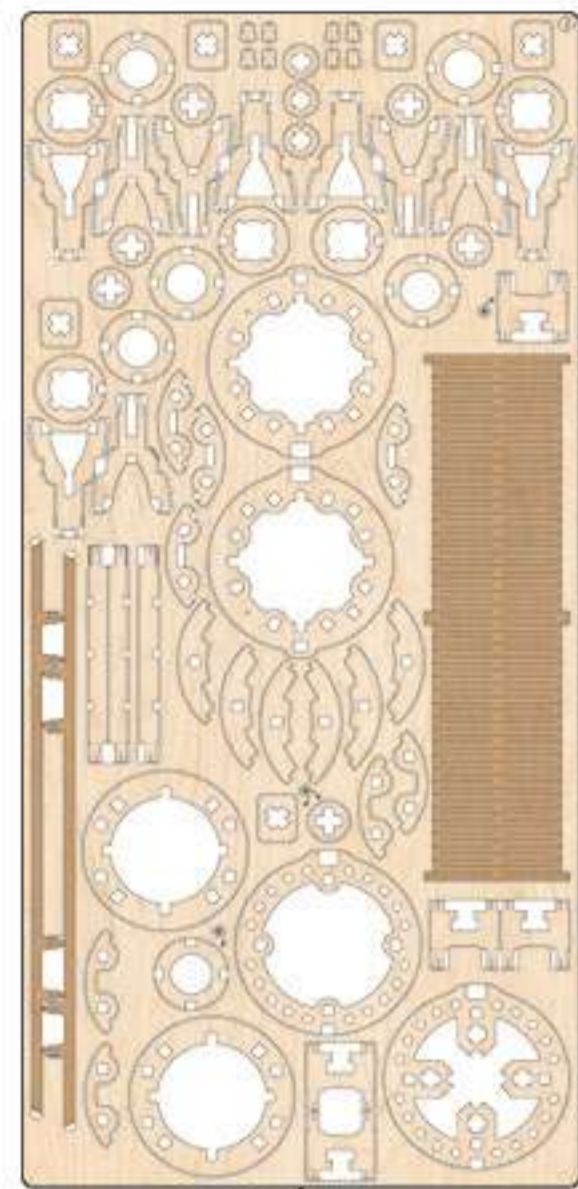

3

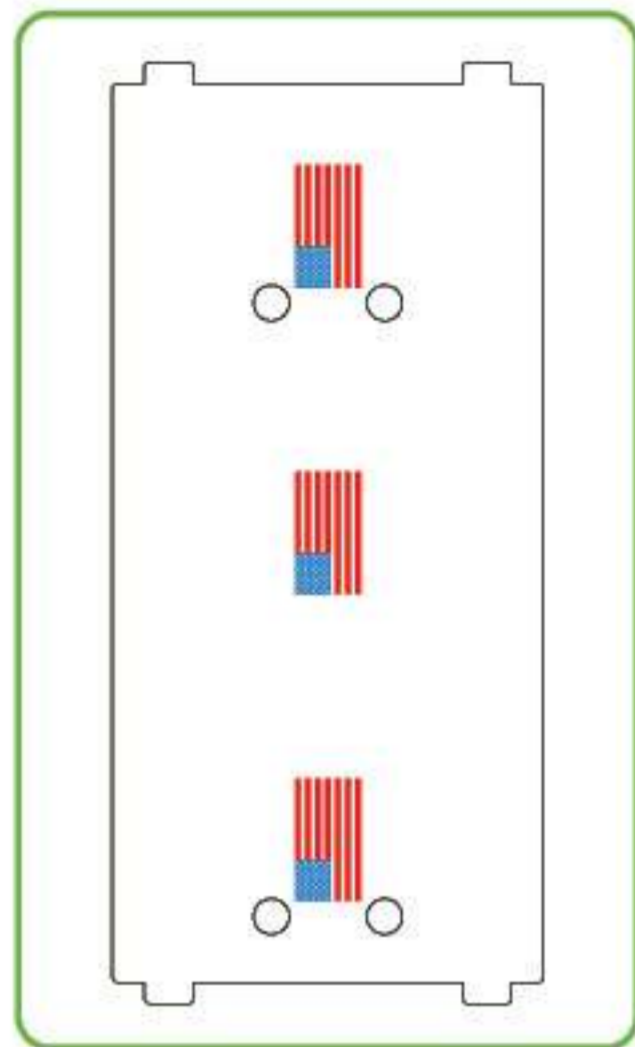

2

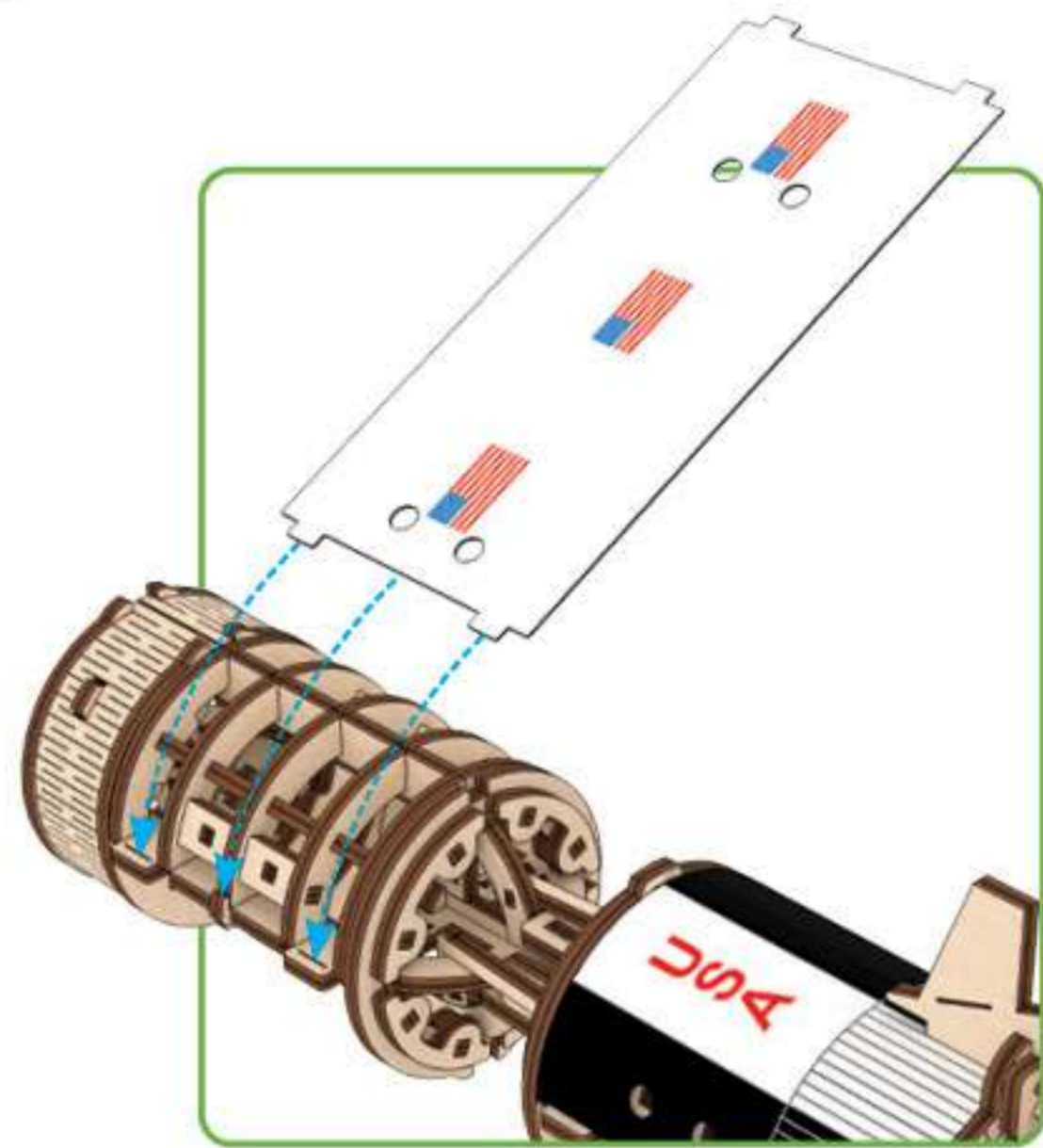

2

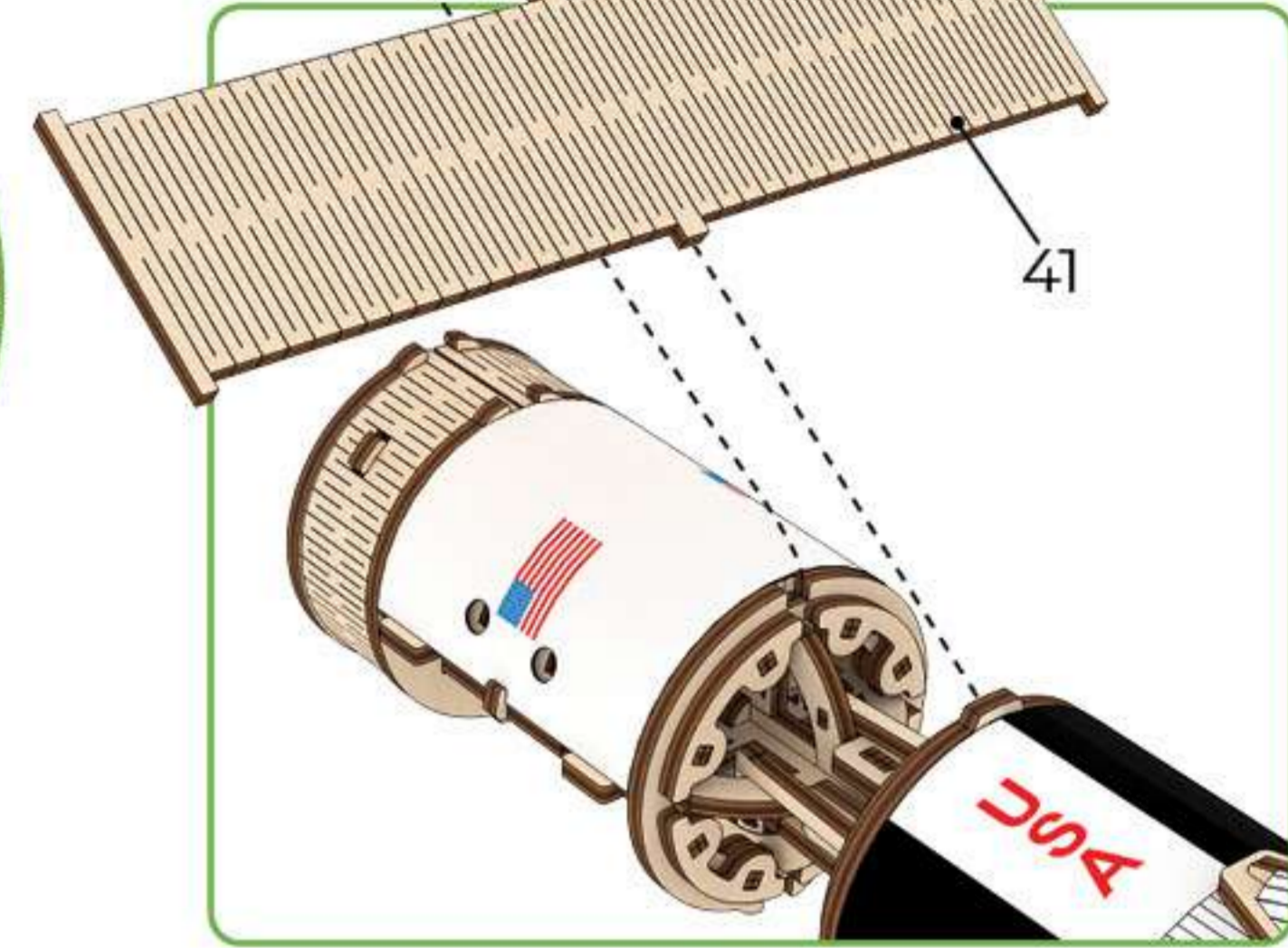
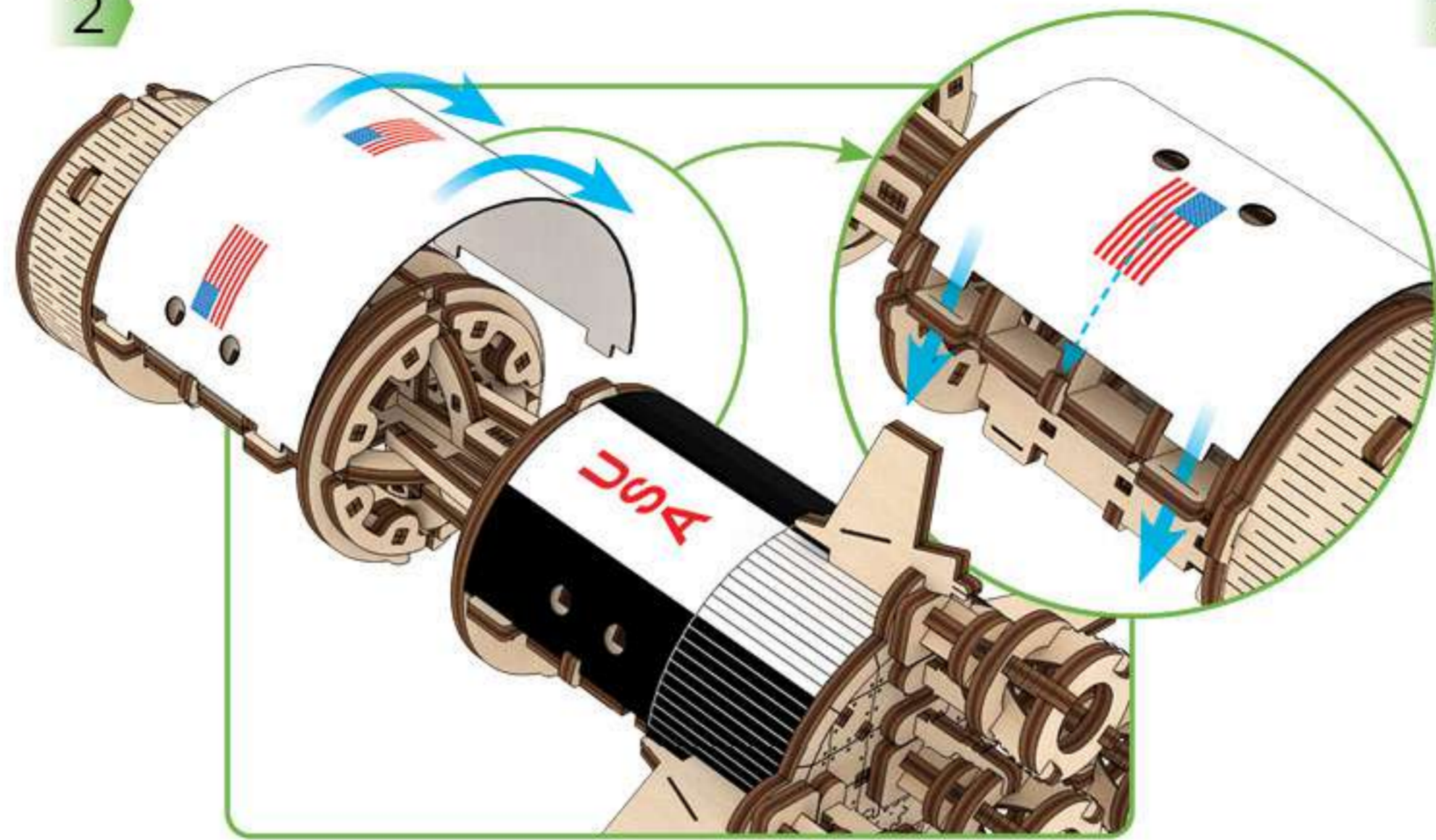

4

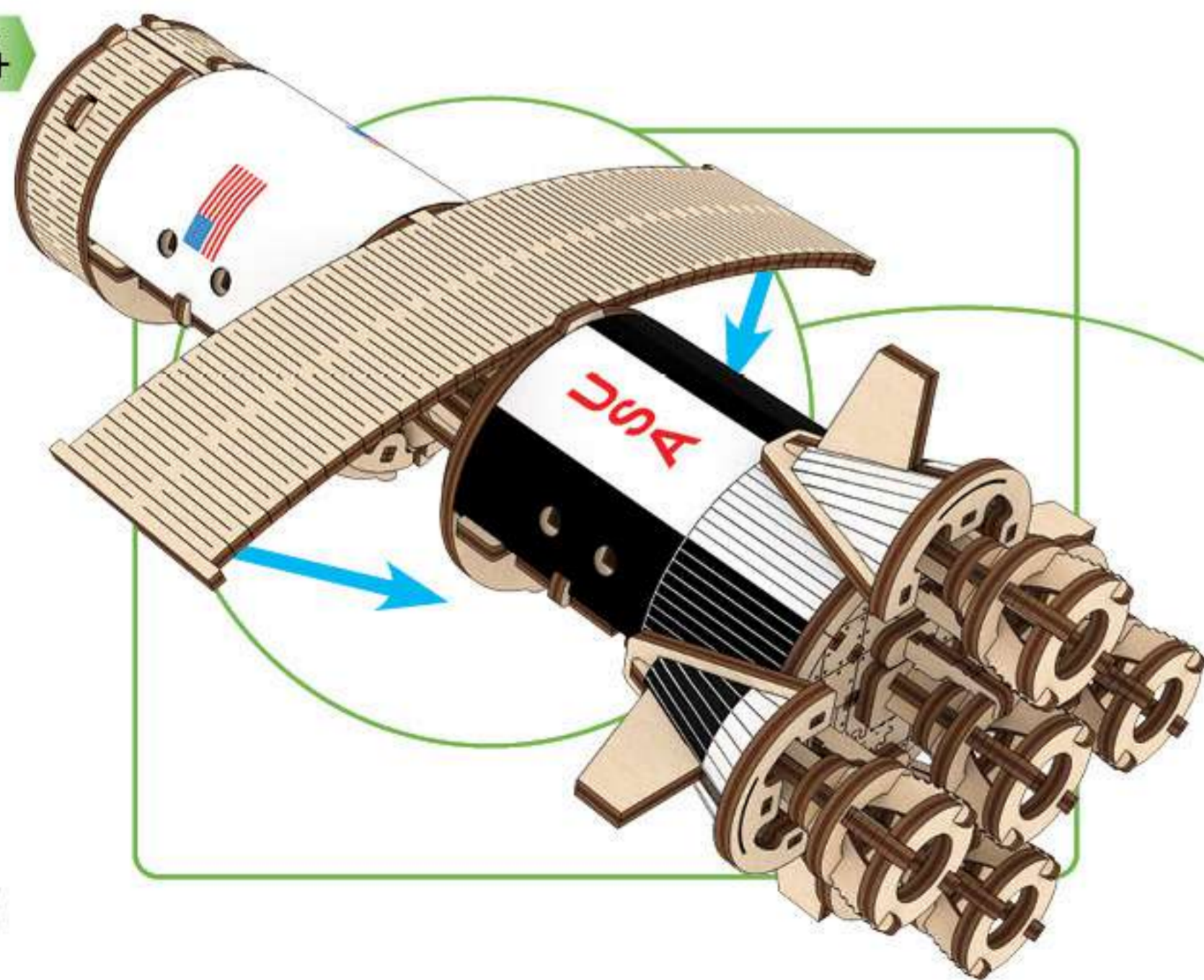

5

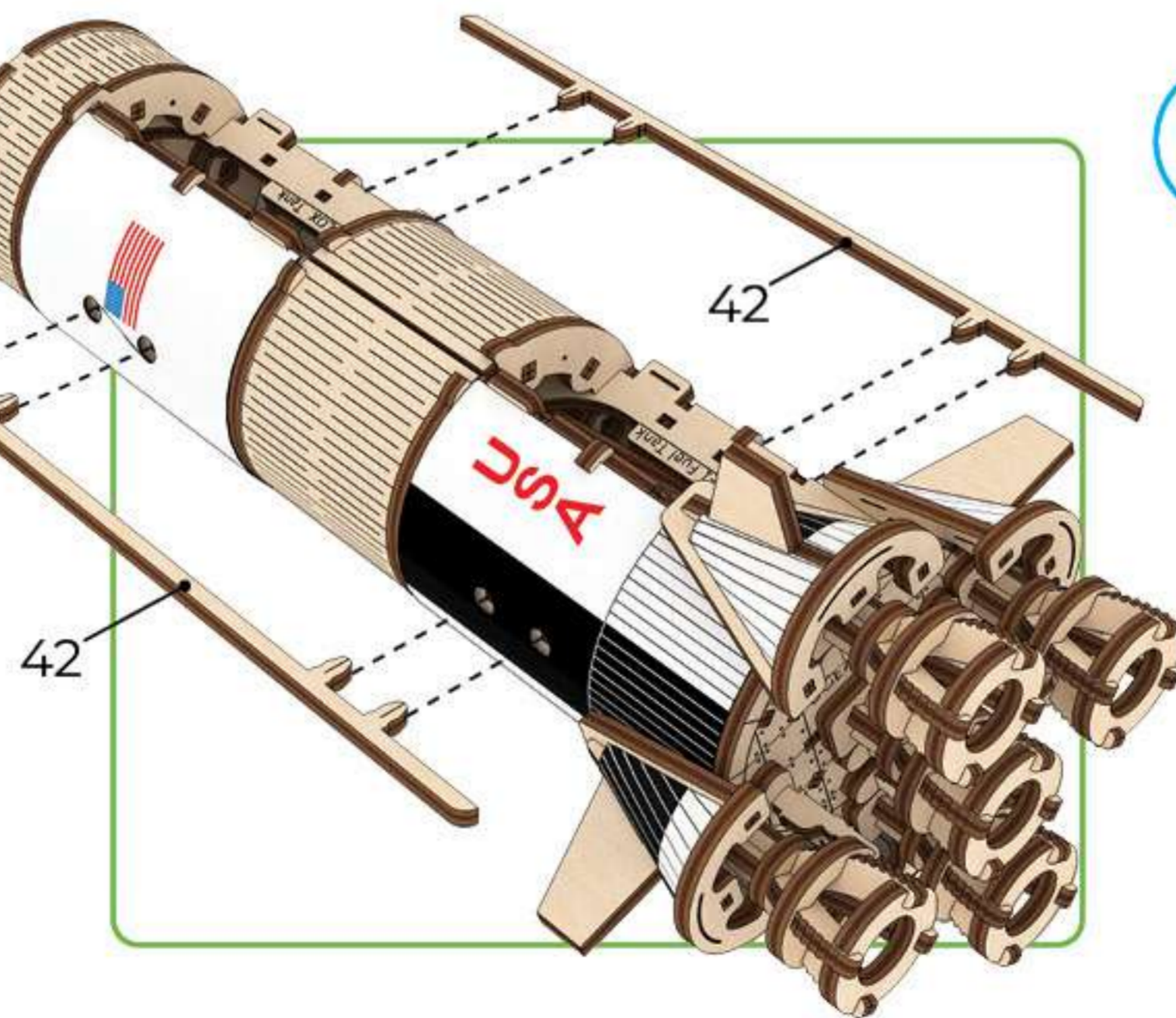
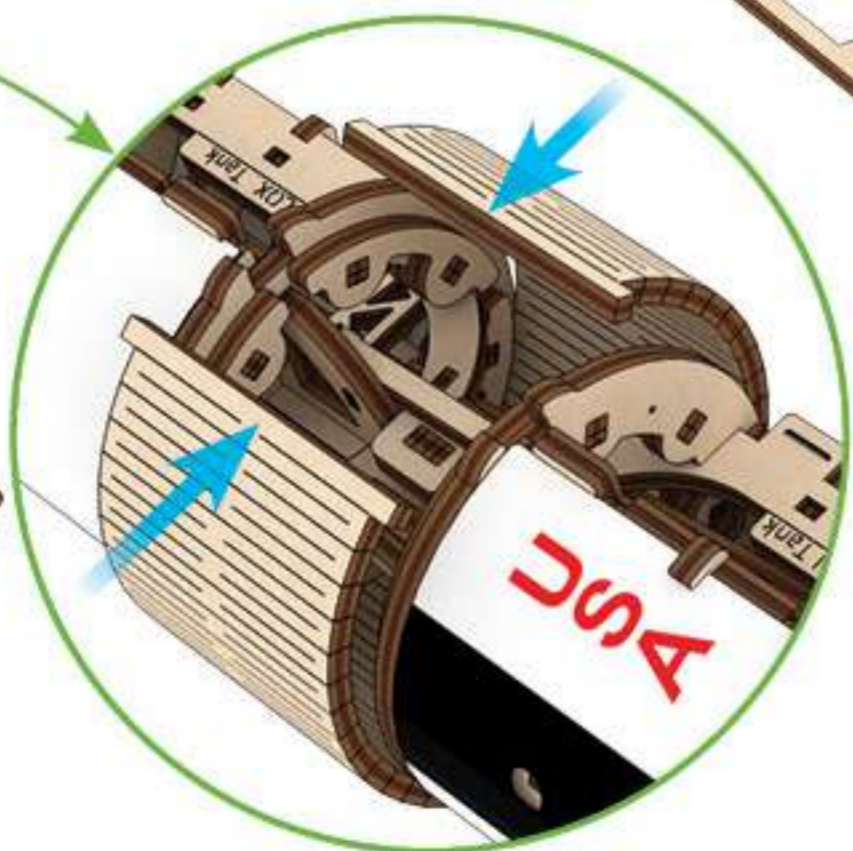

c7

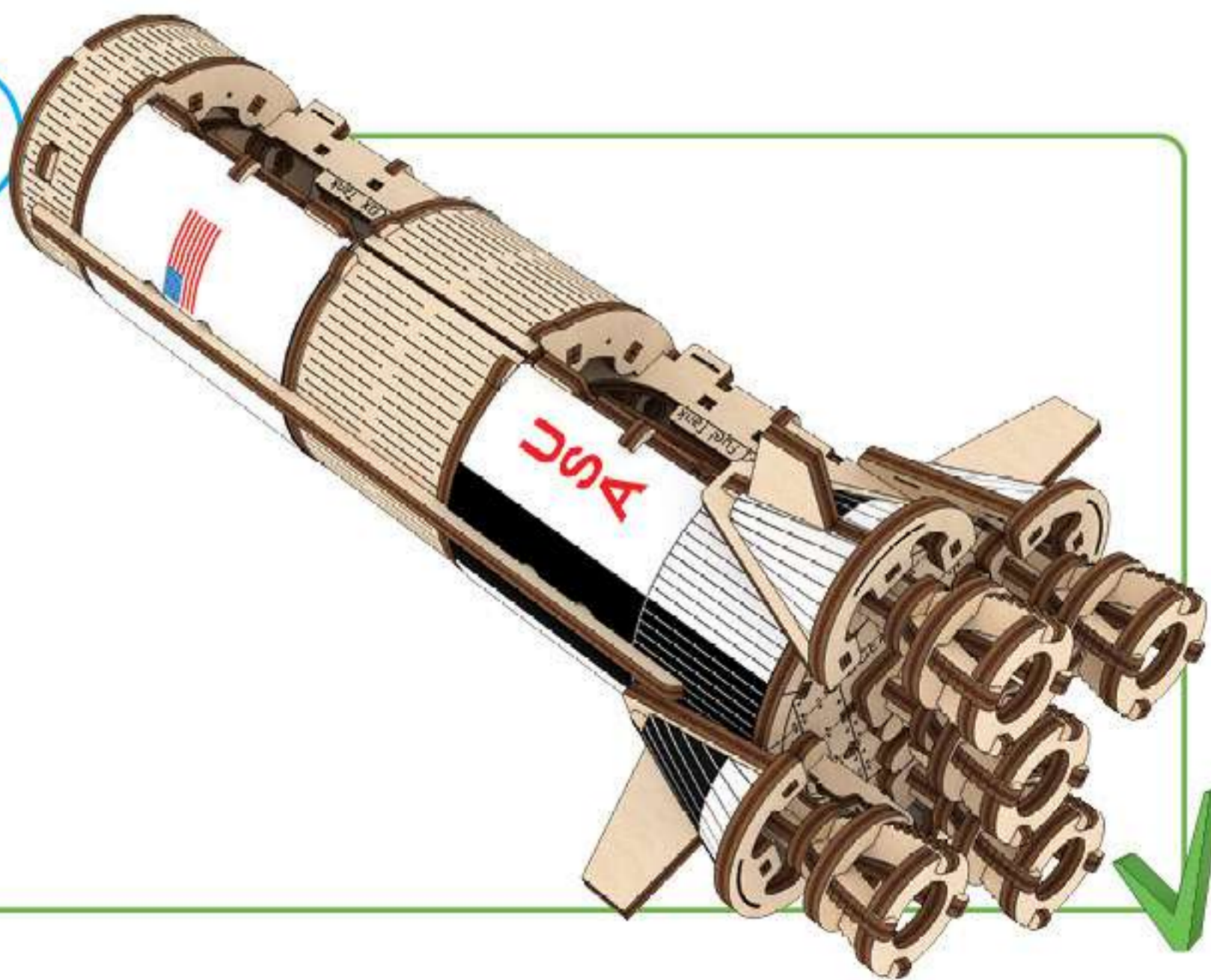

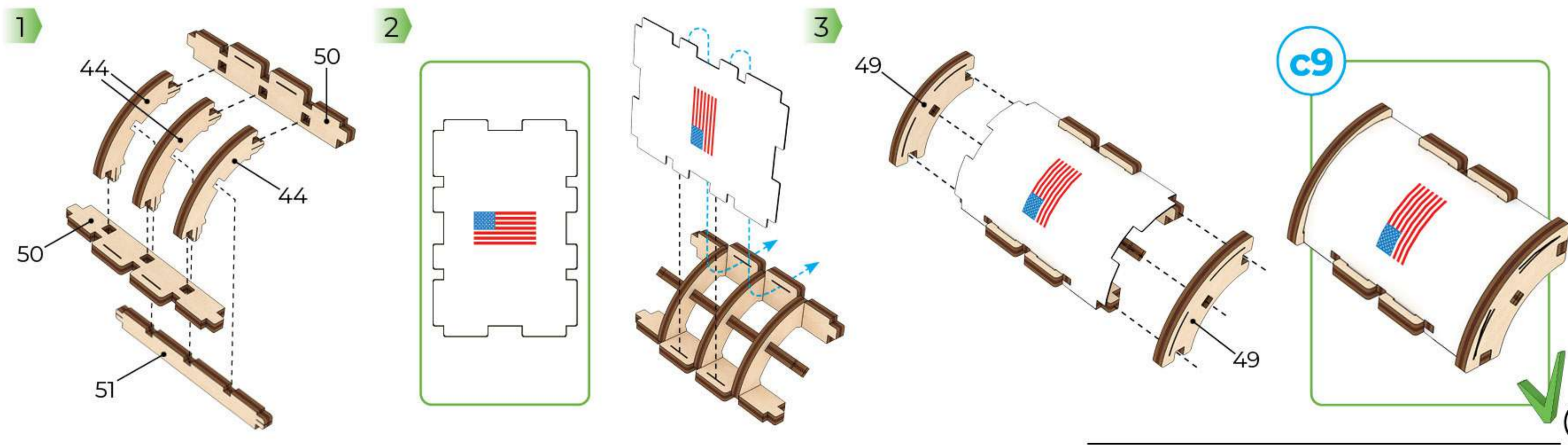
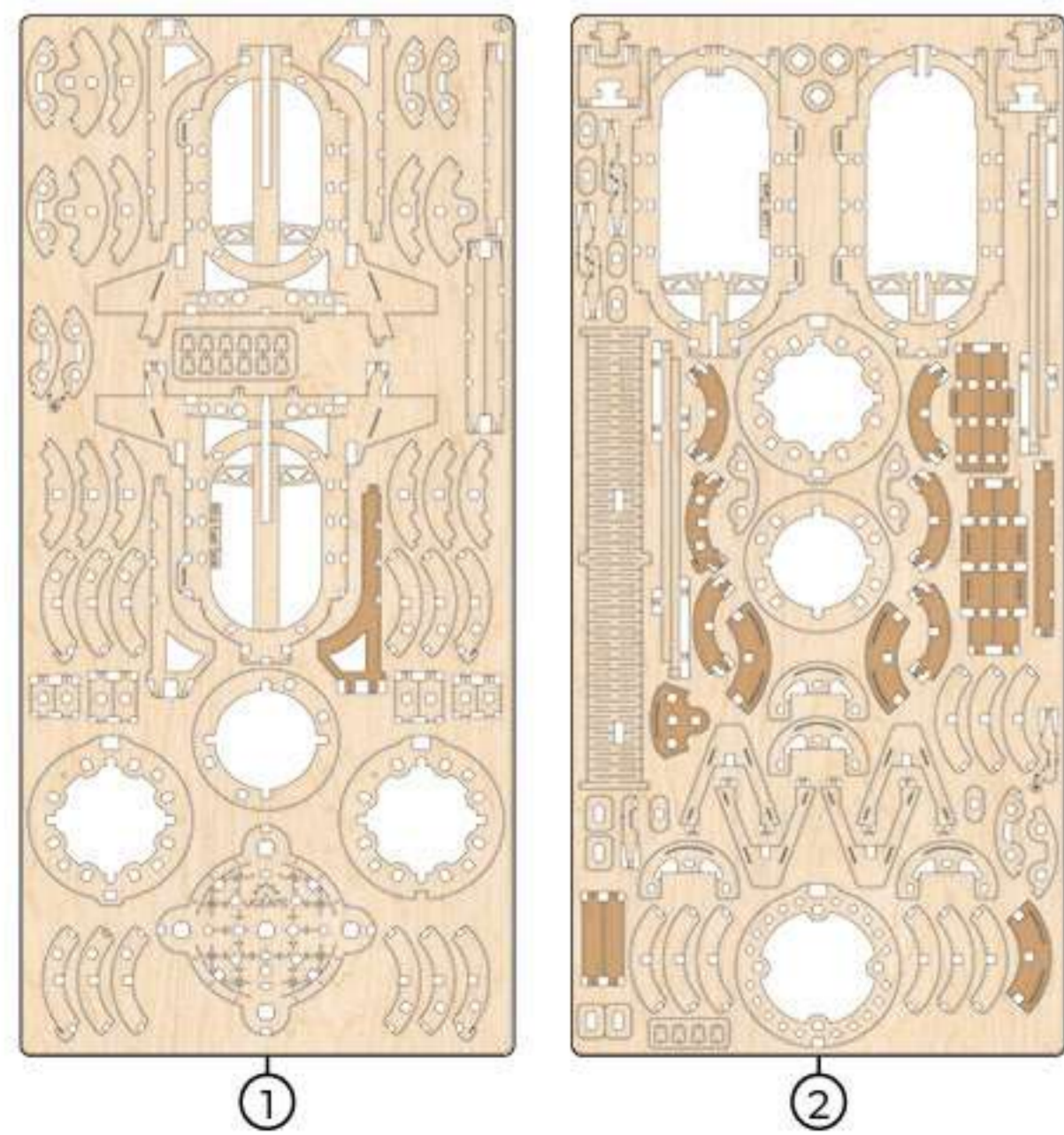
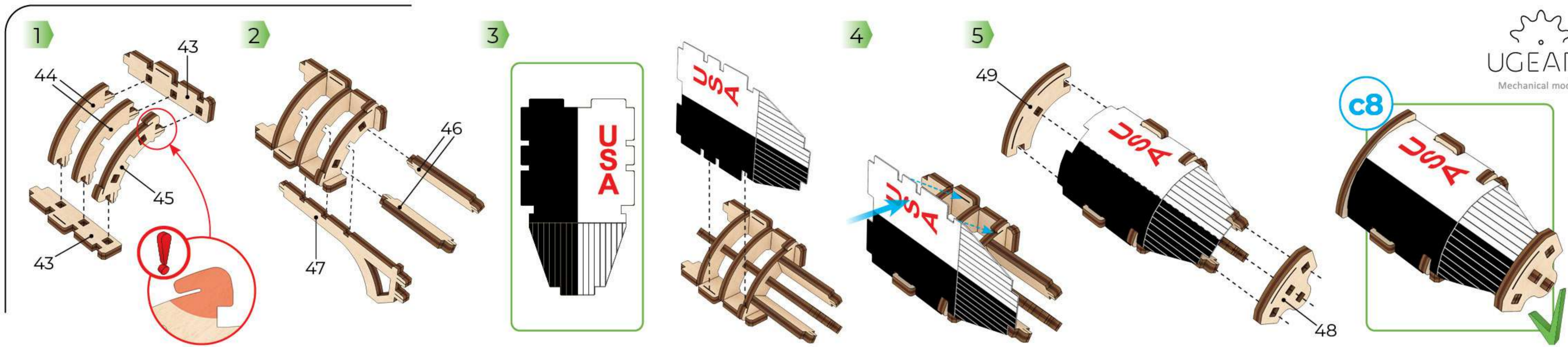

1

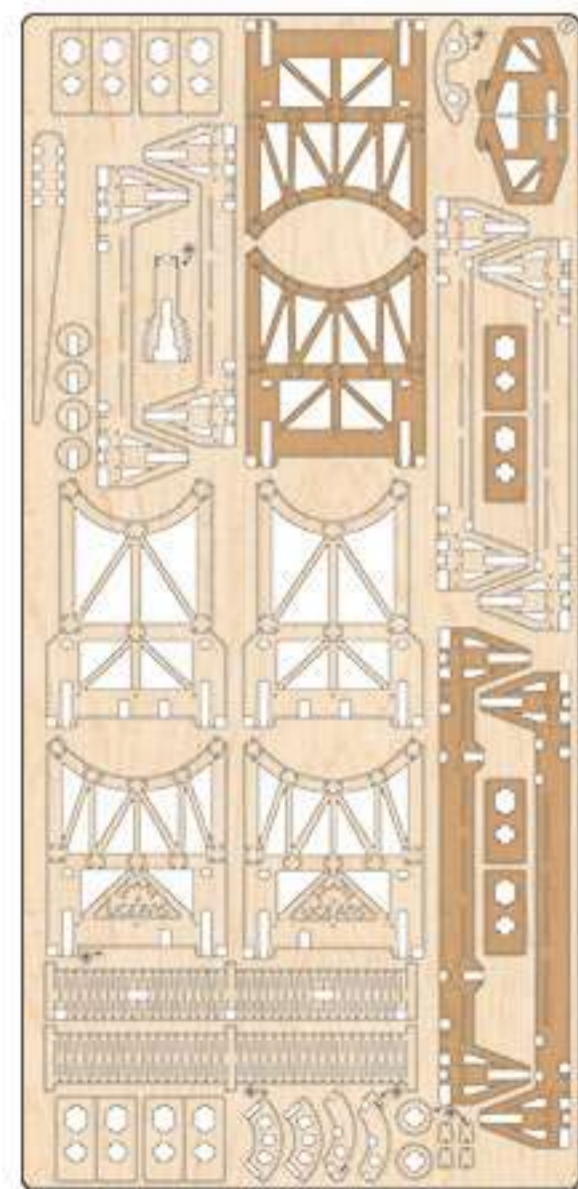
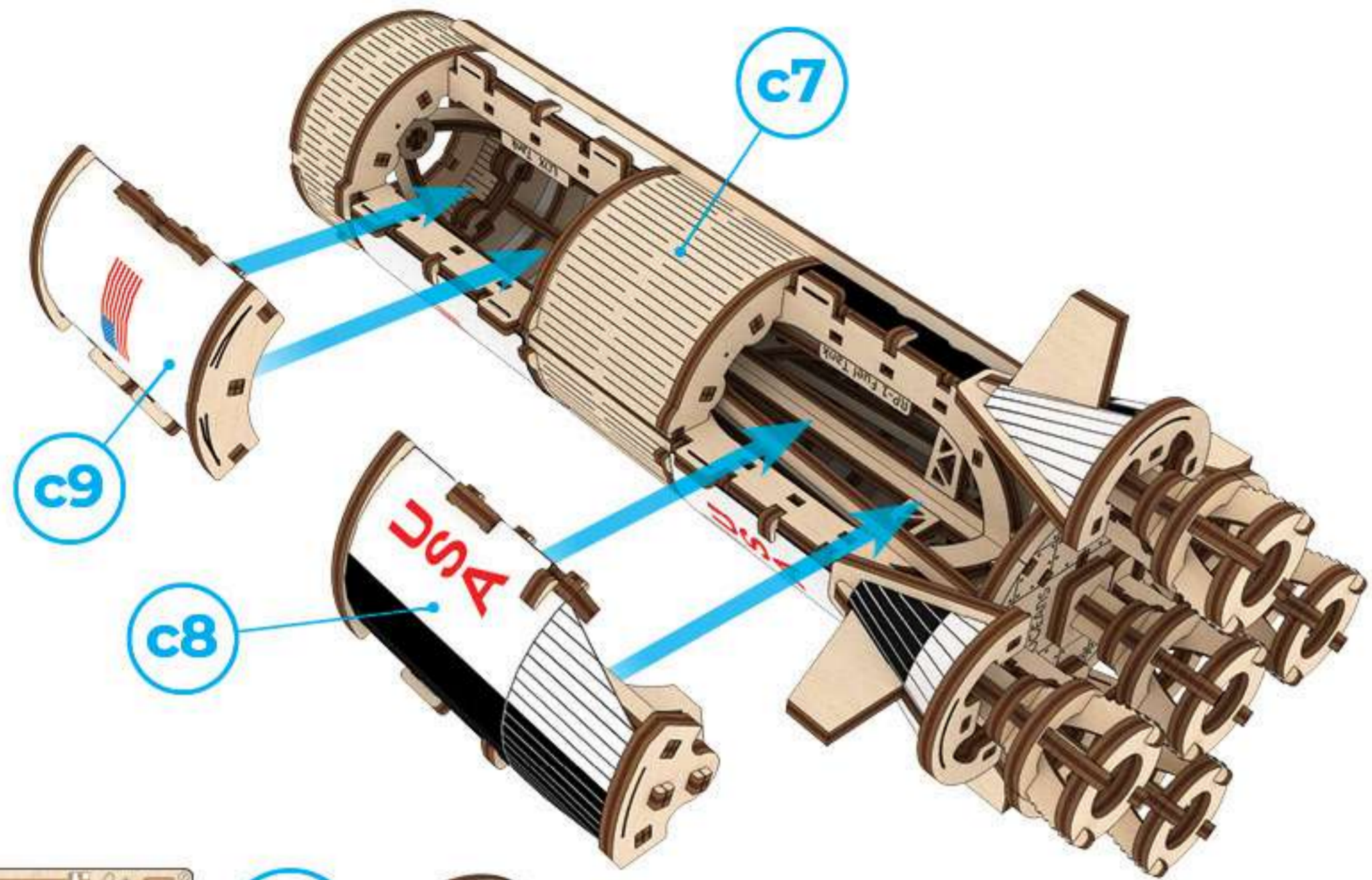

7

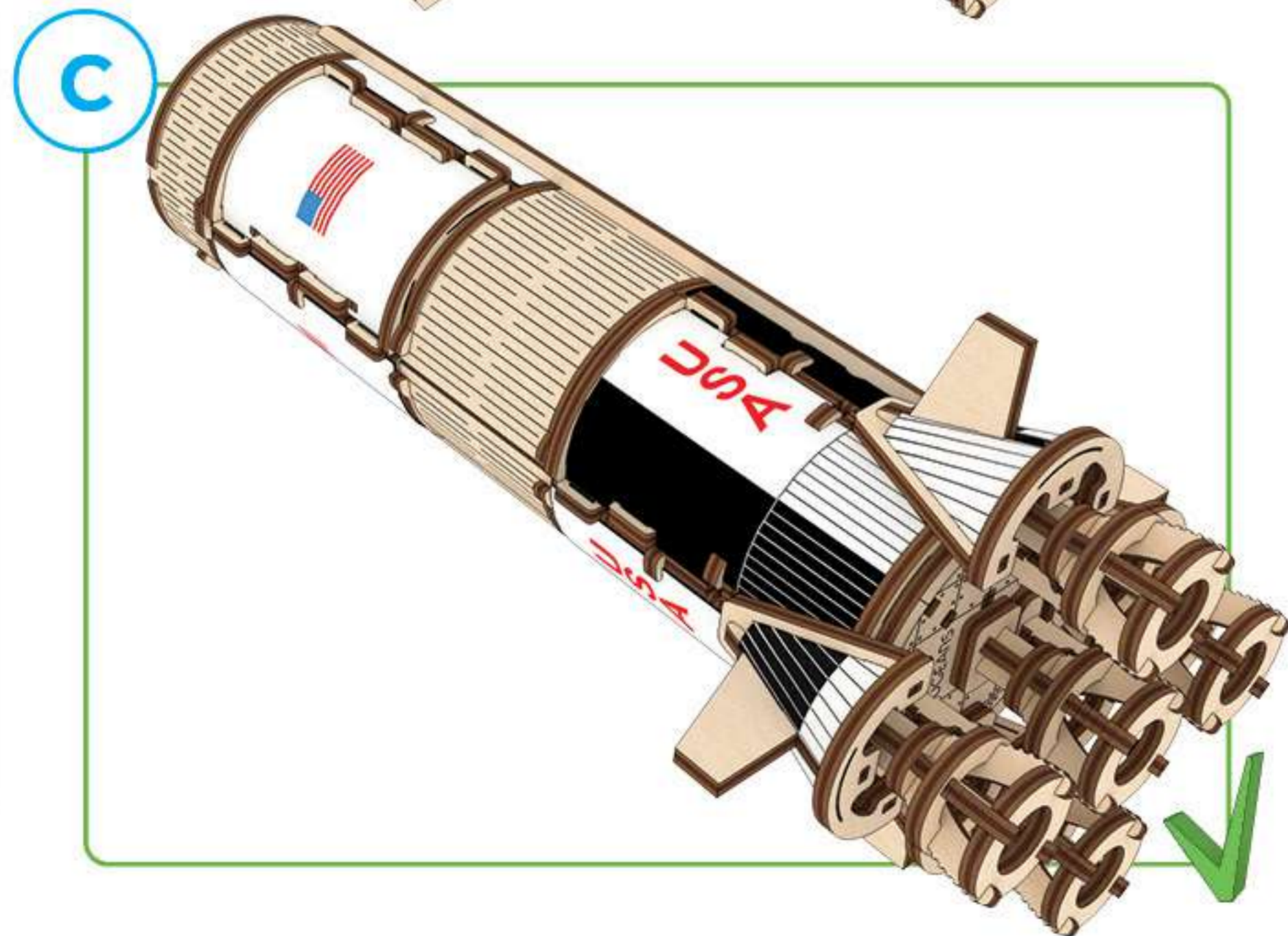

1

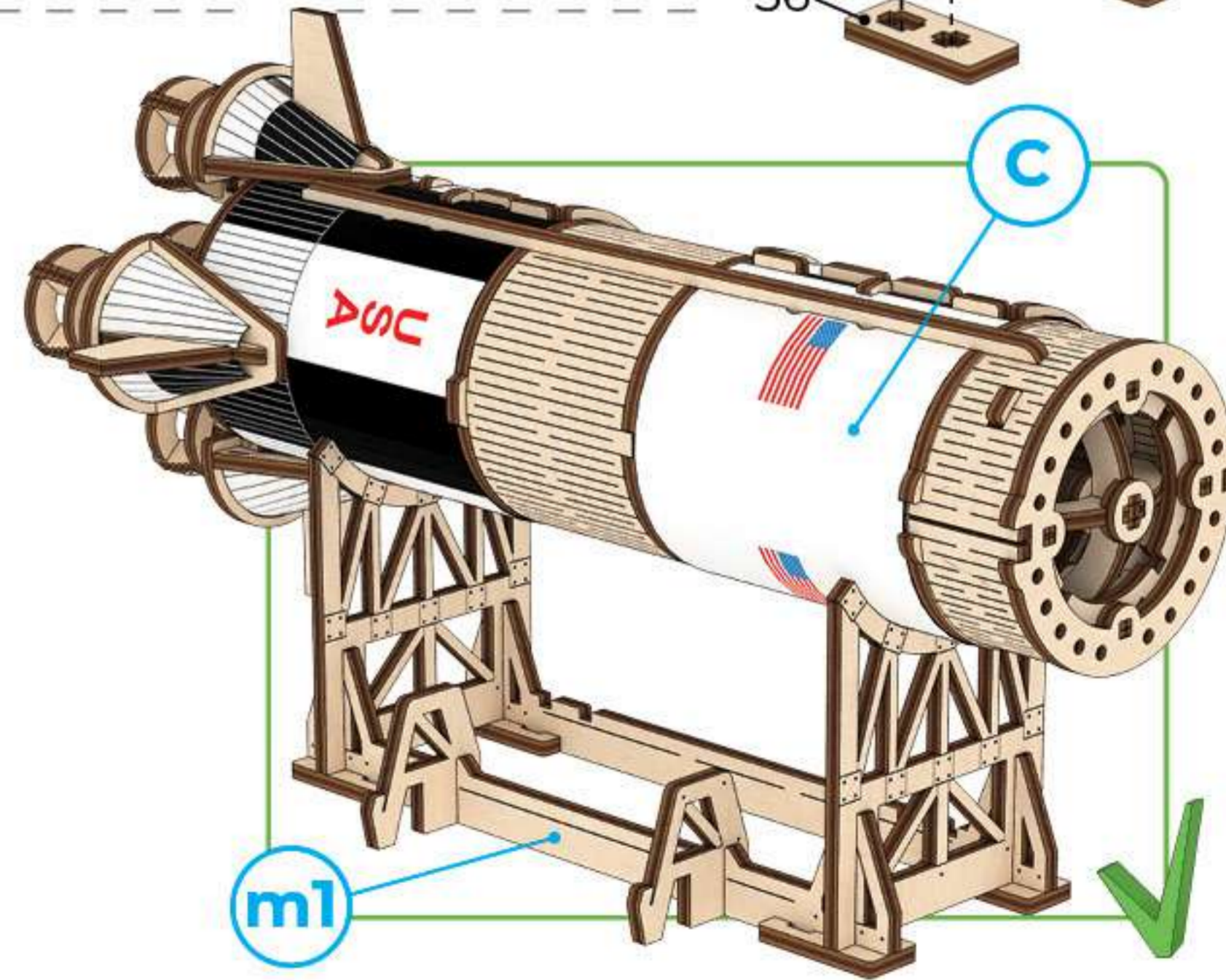
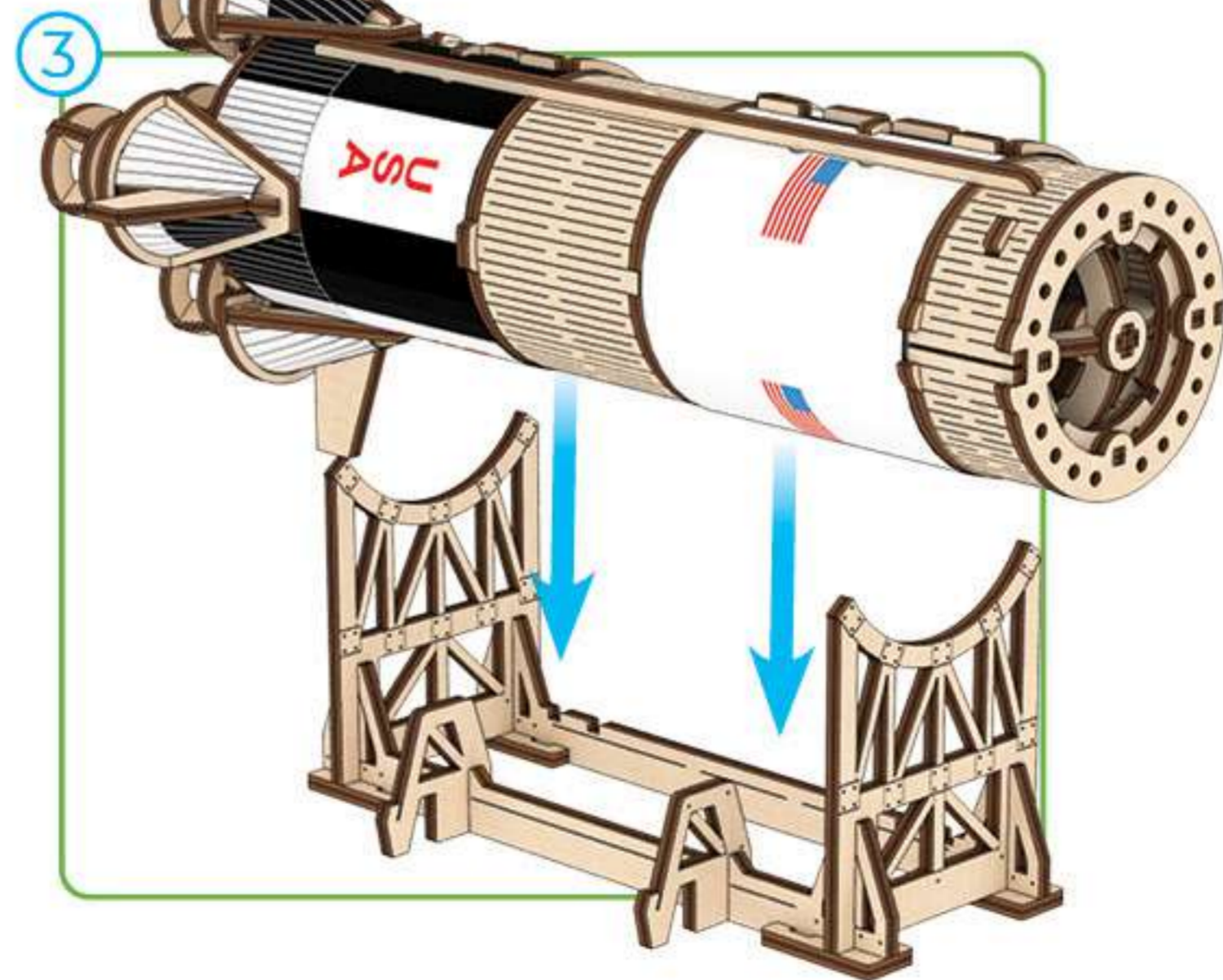
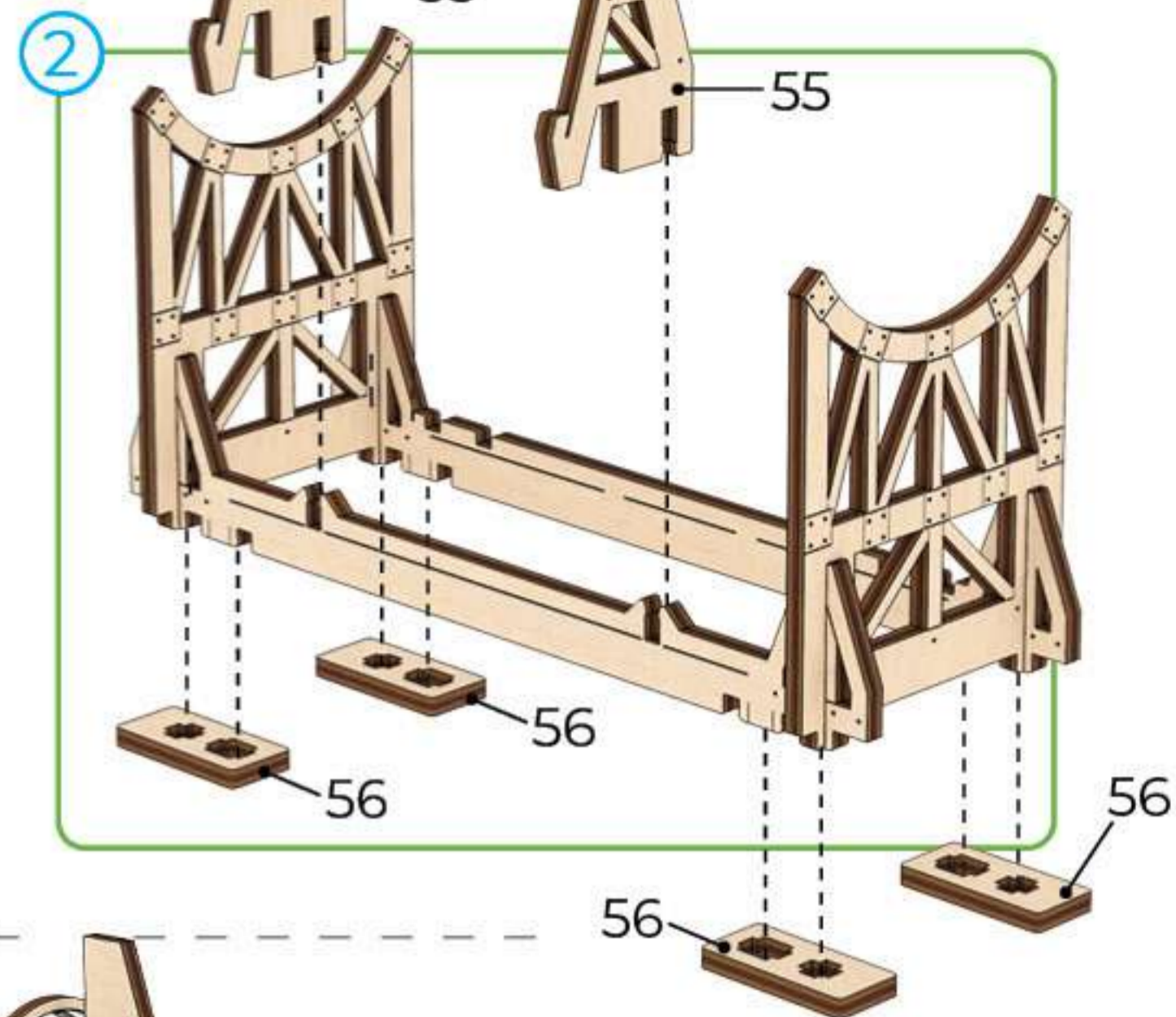
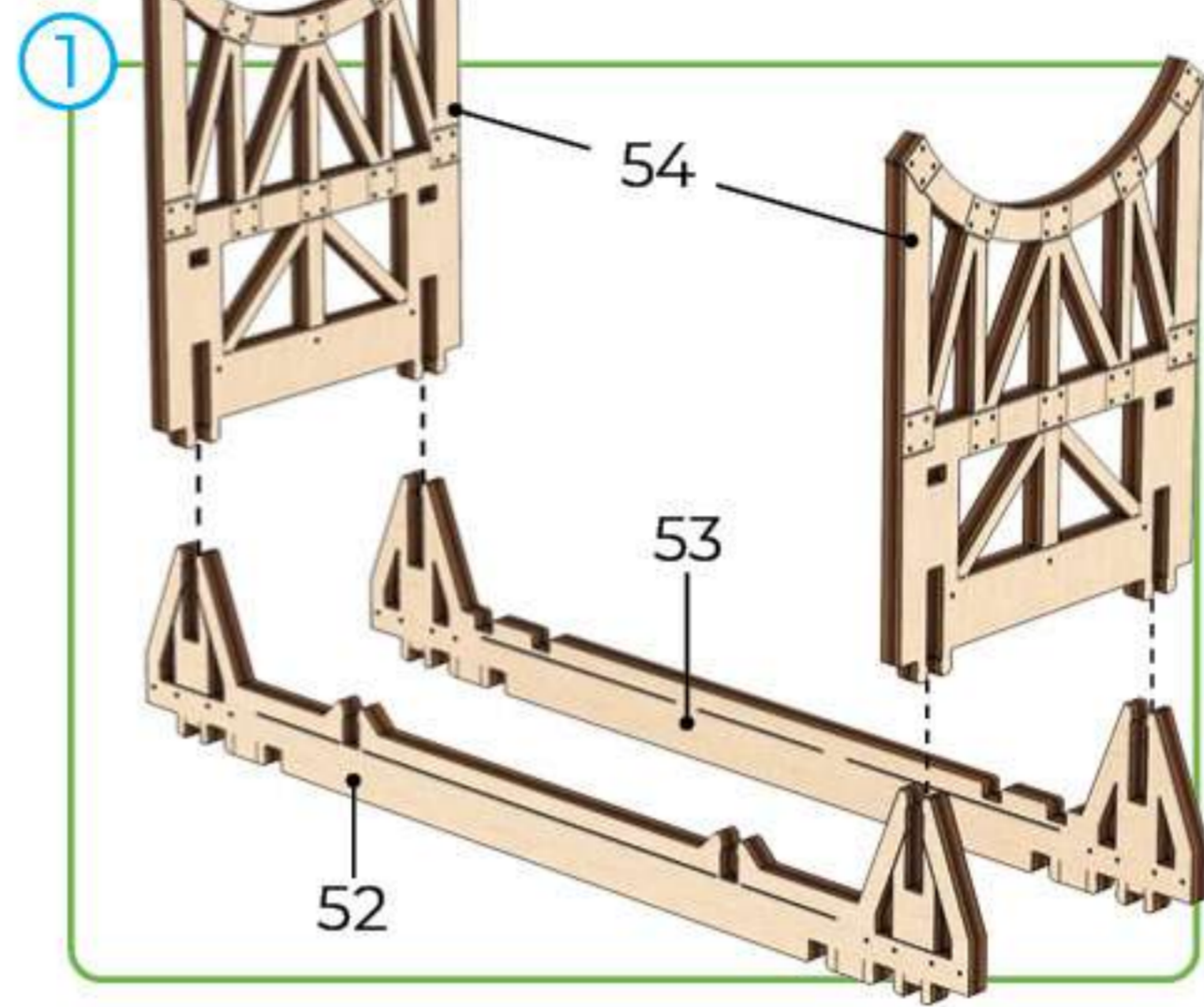



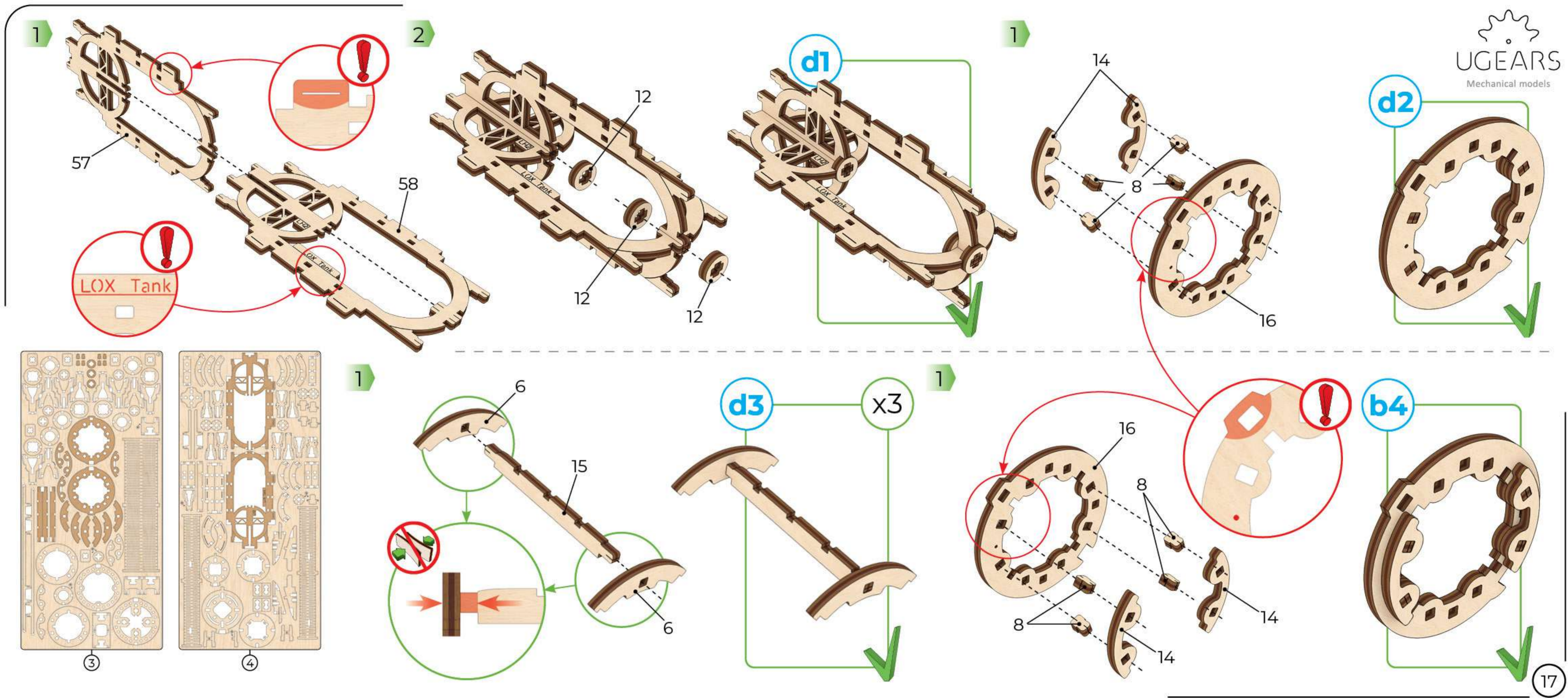

1

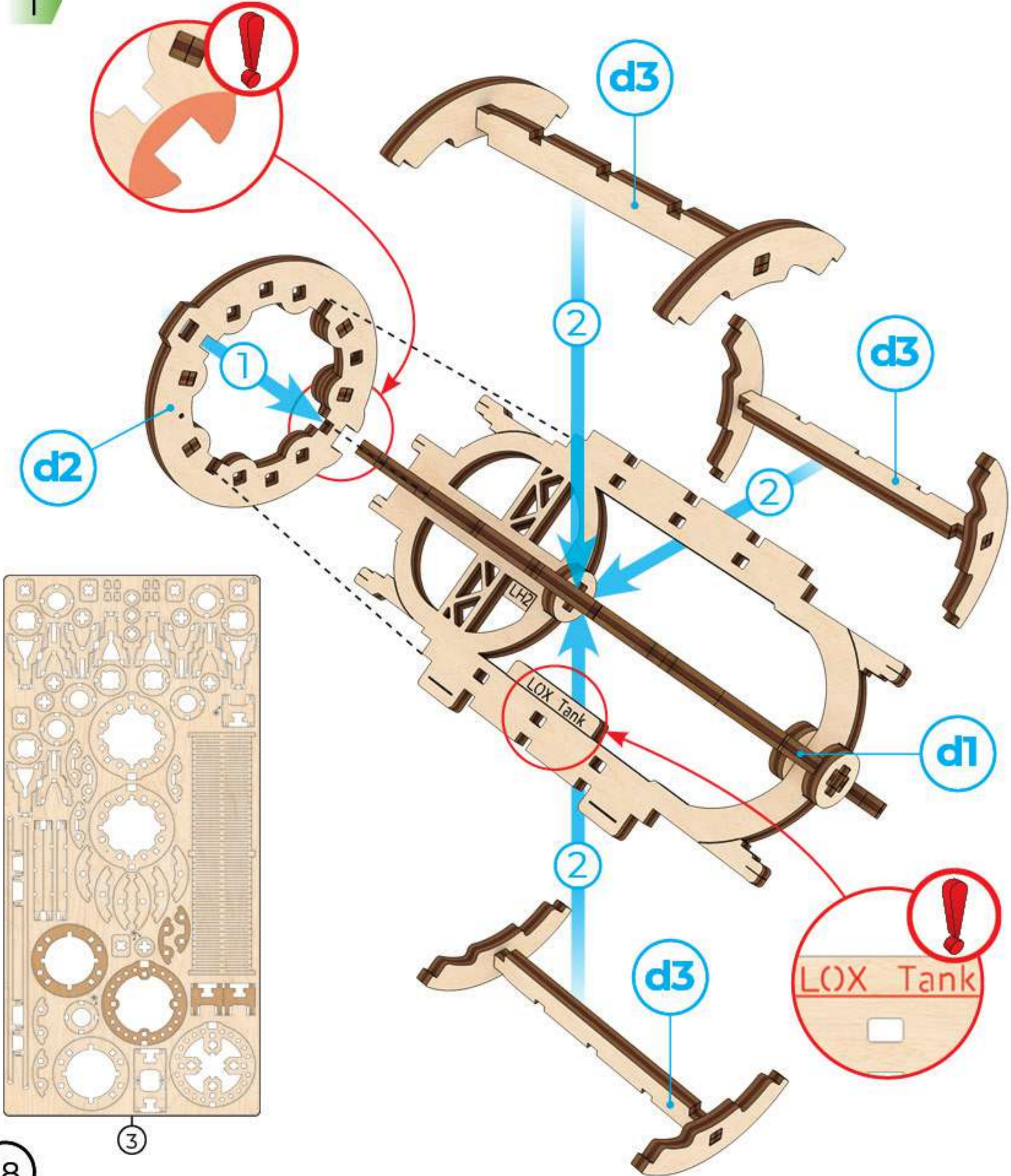

2

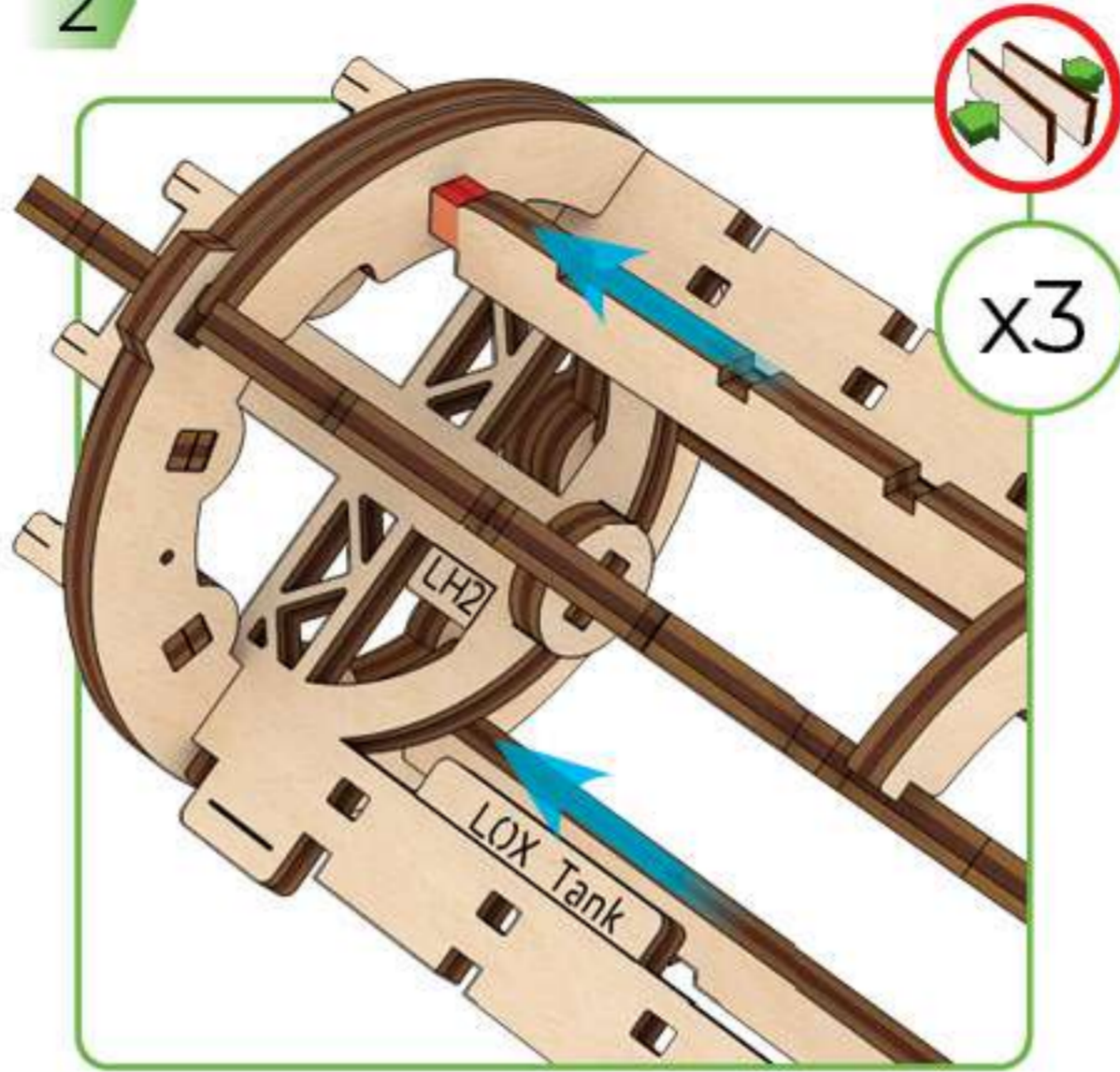

3

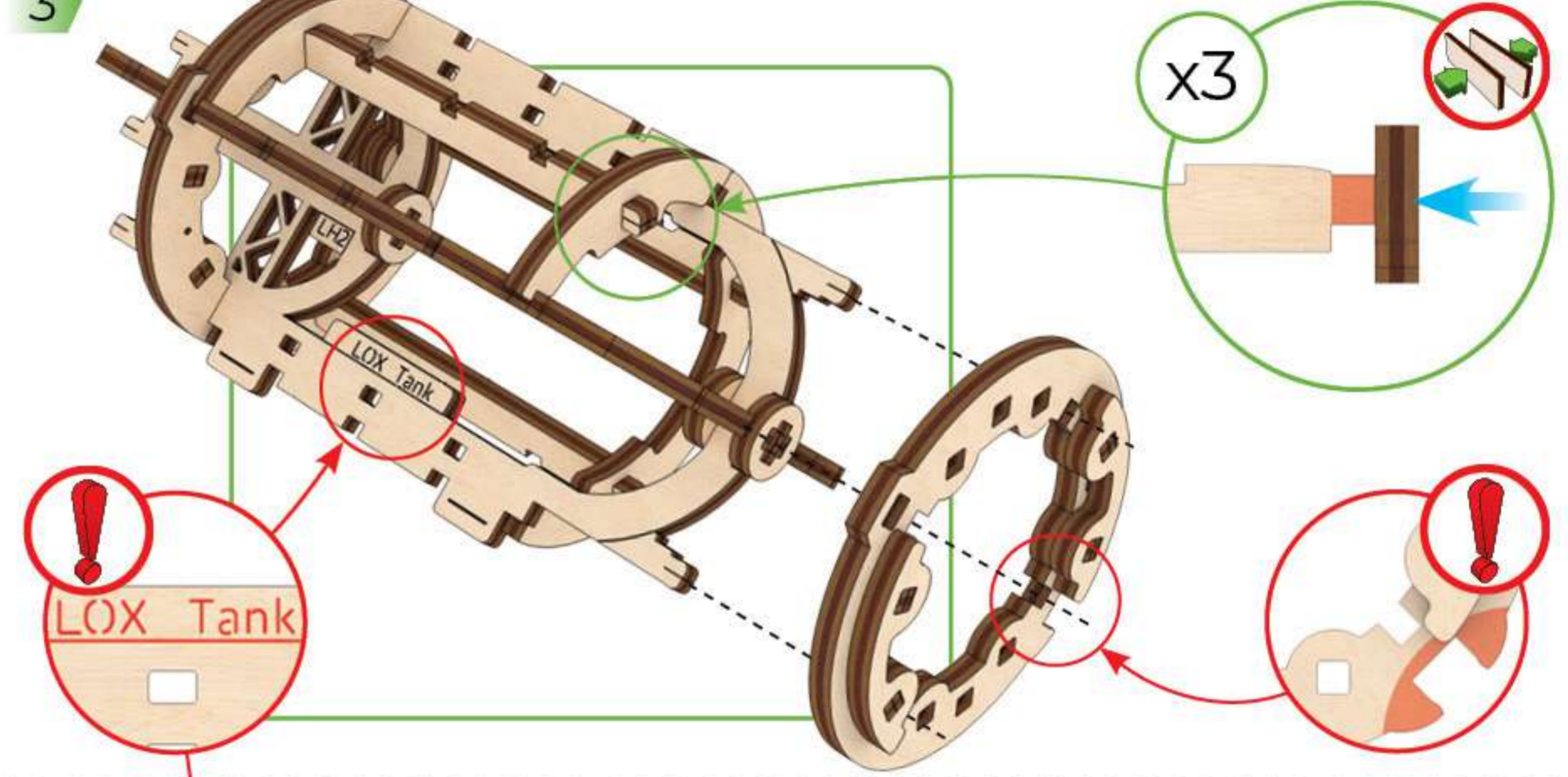

4

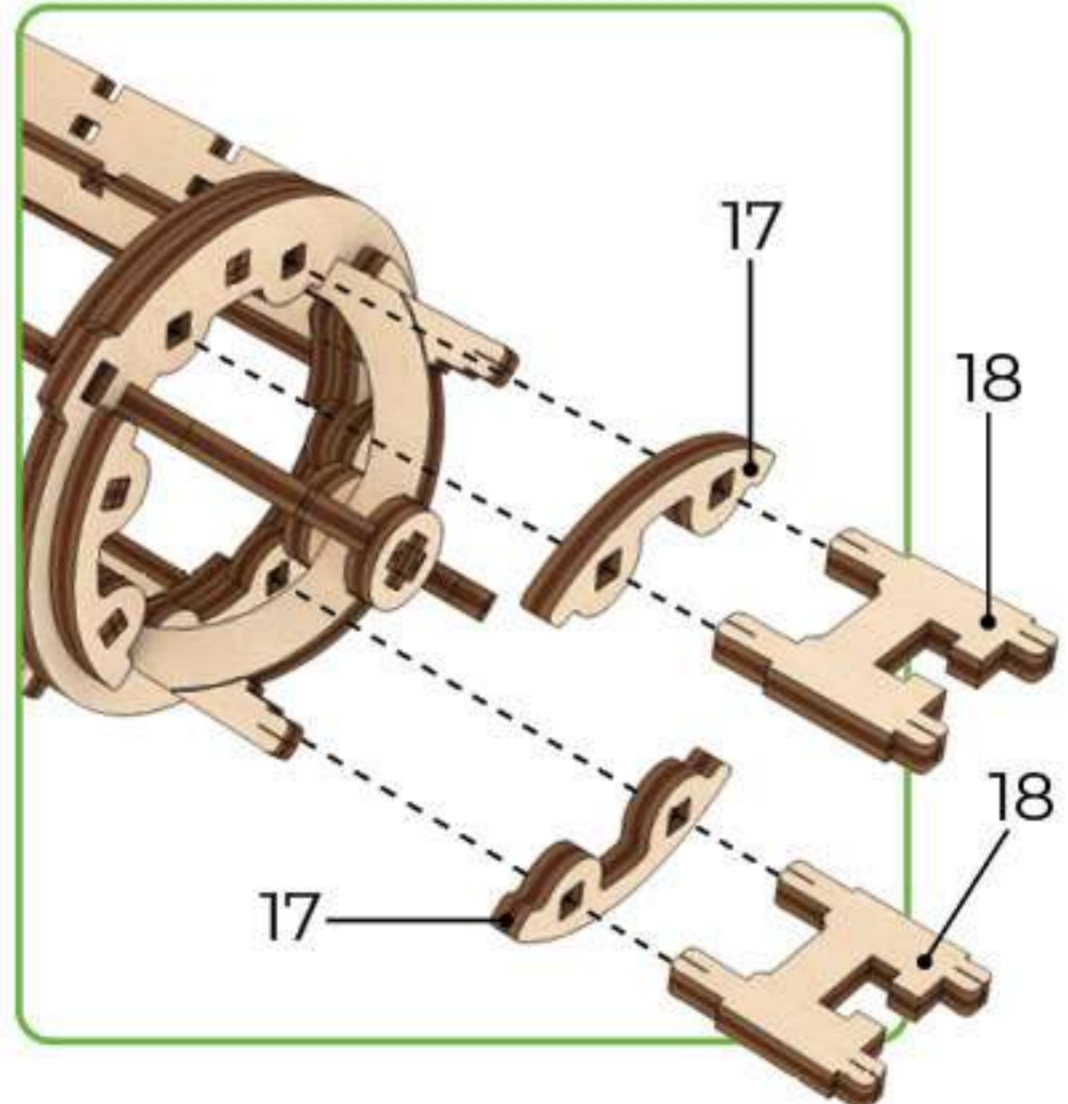

5

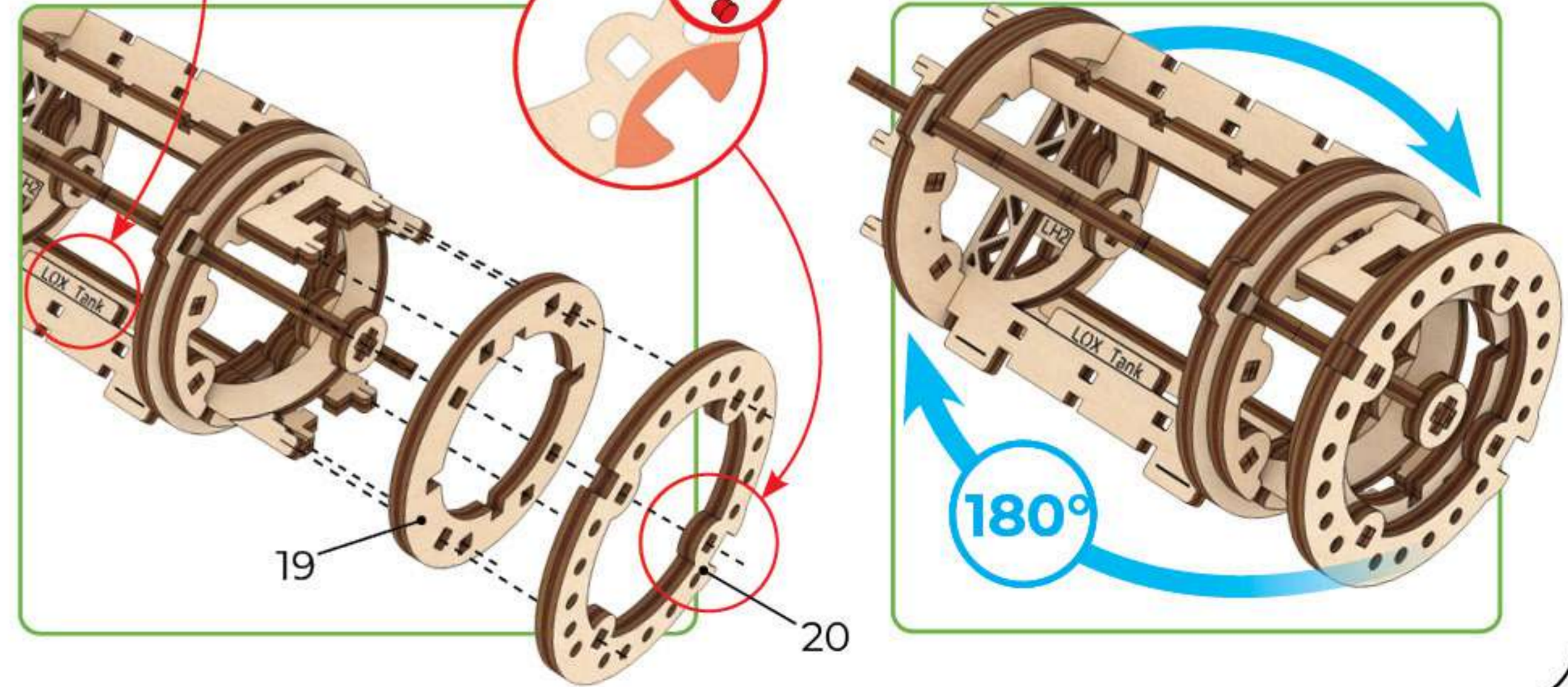

6

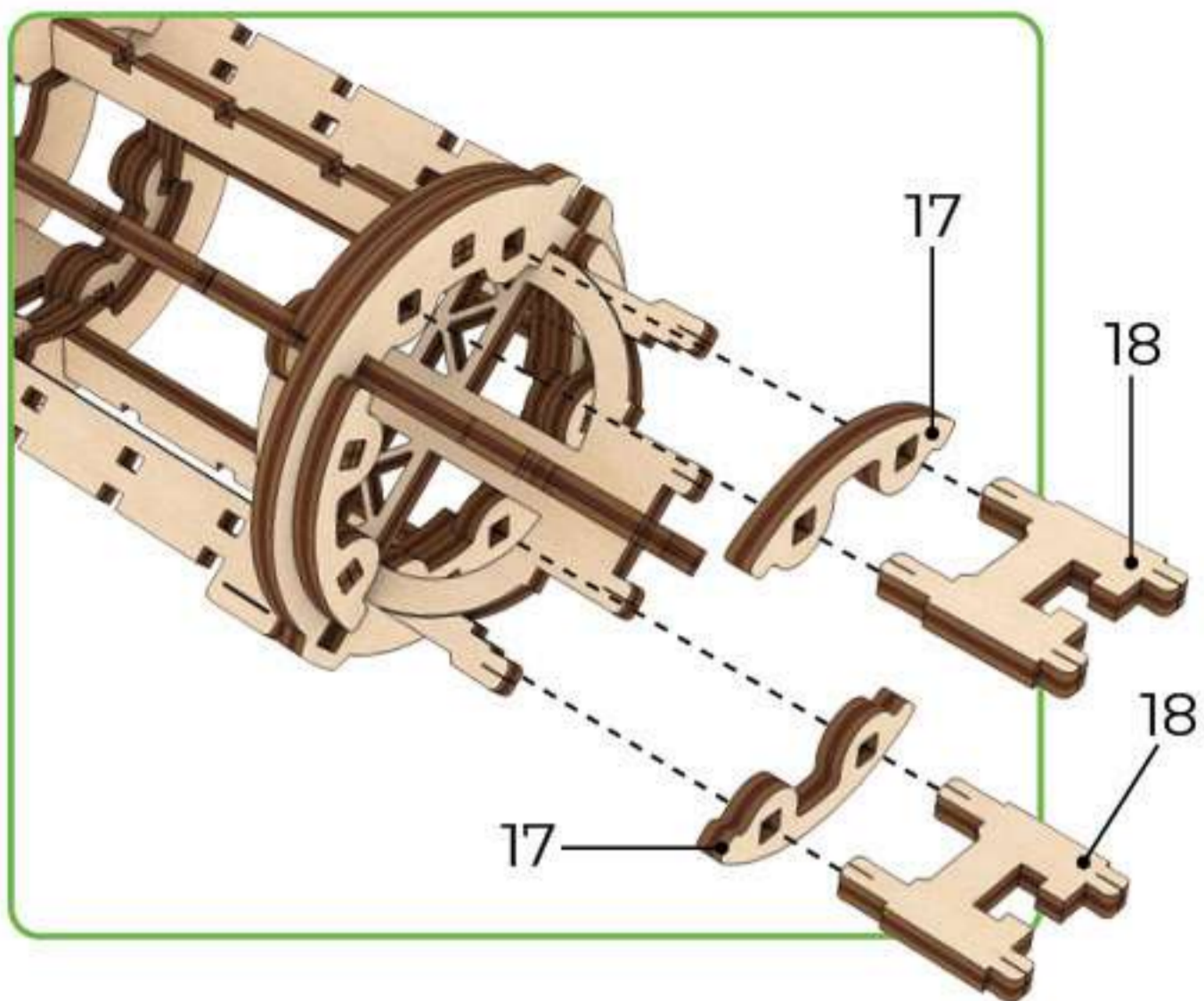

7

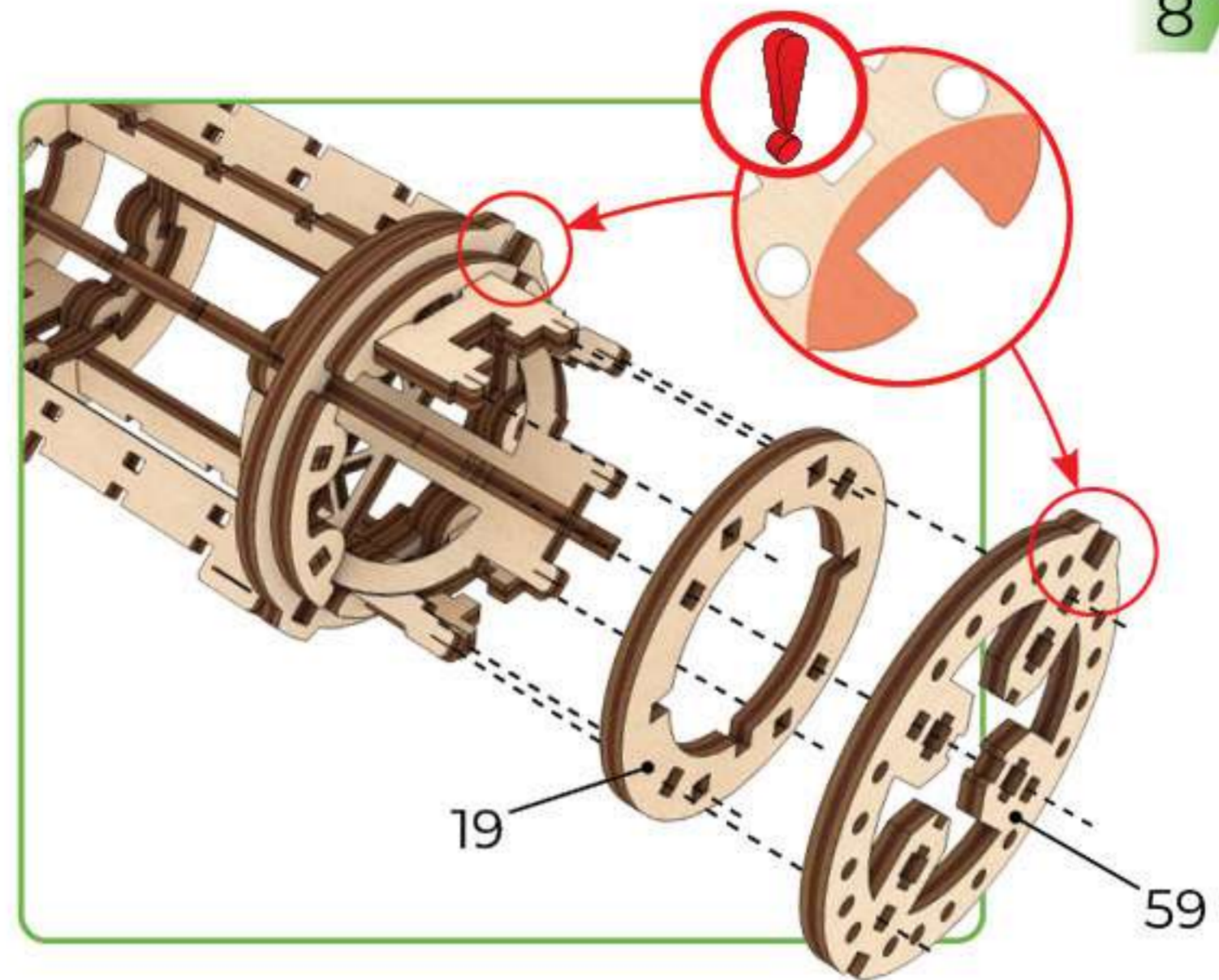

8

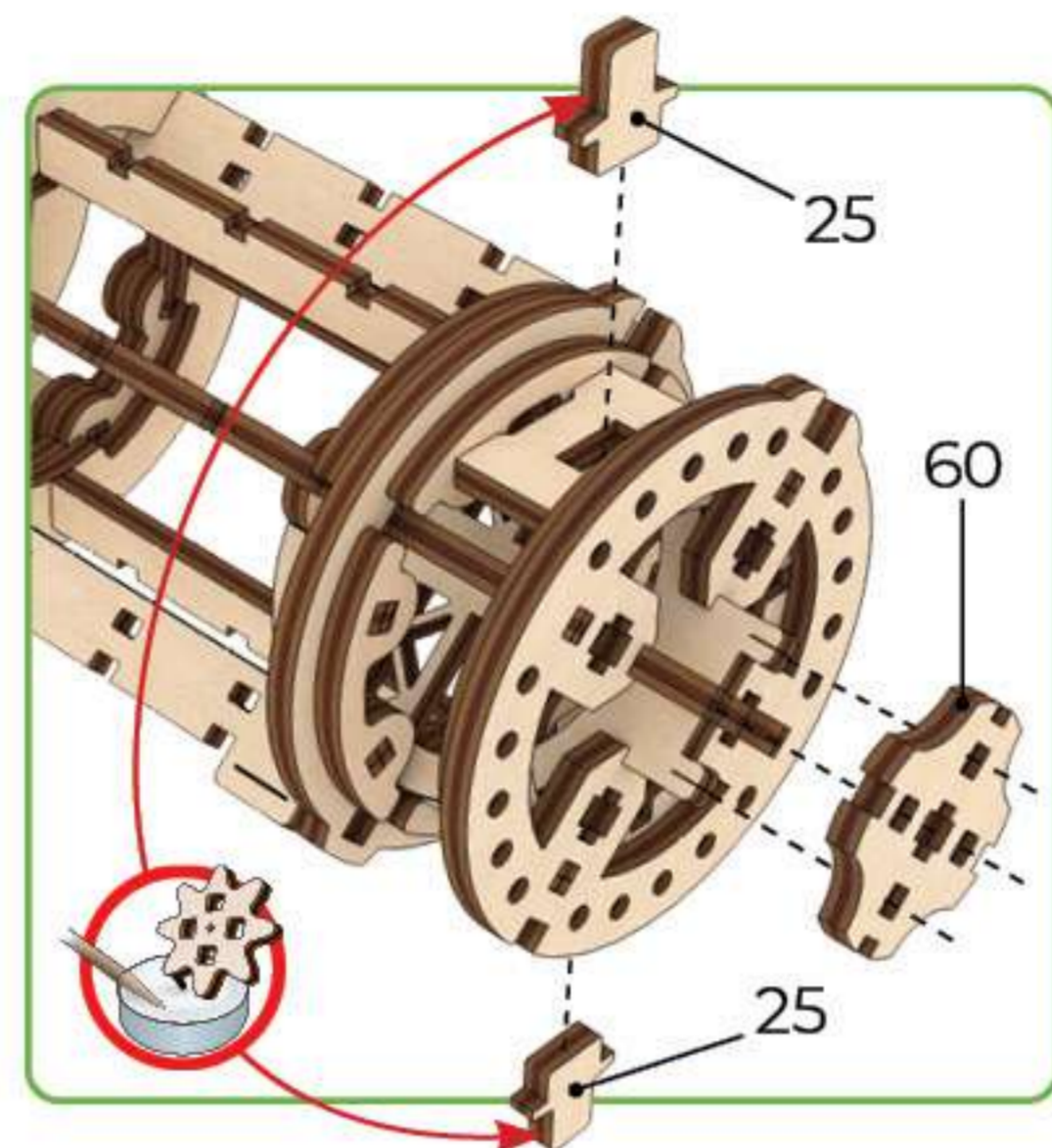

9

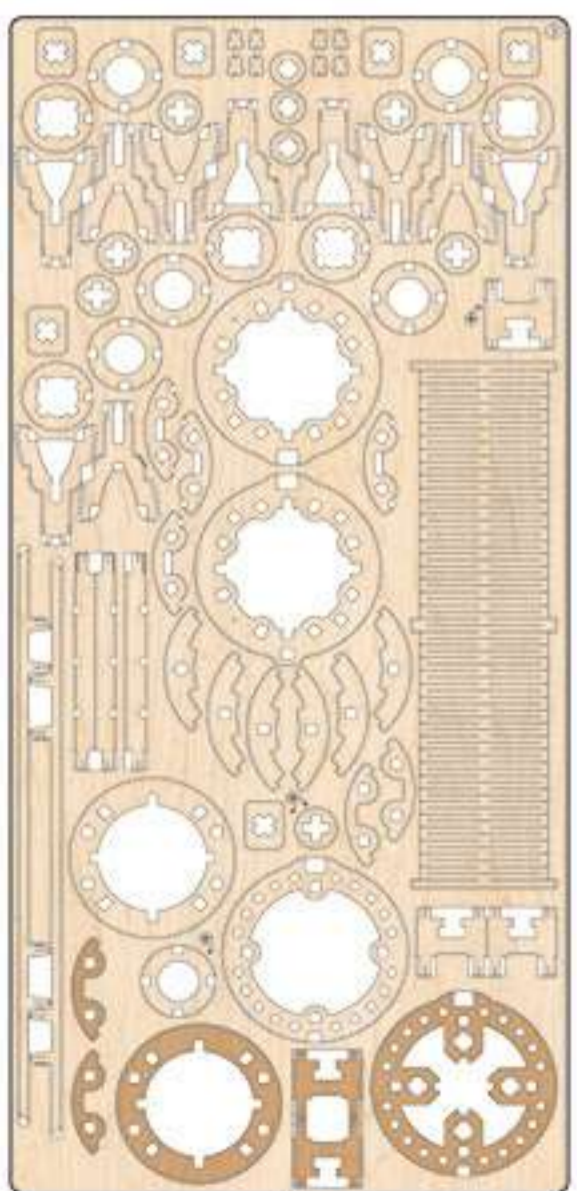
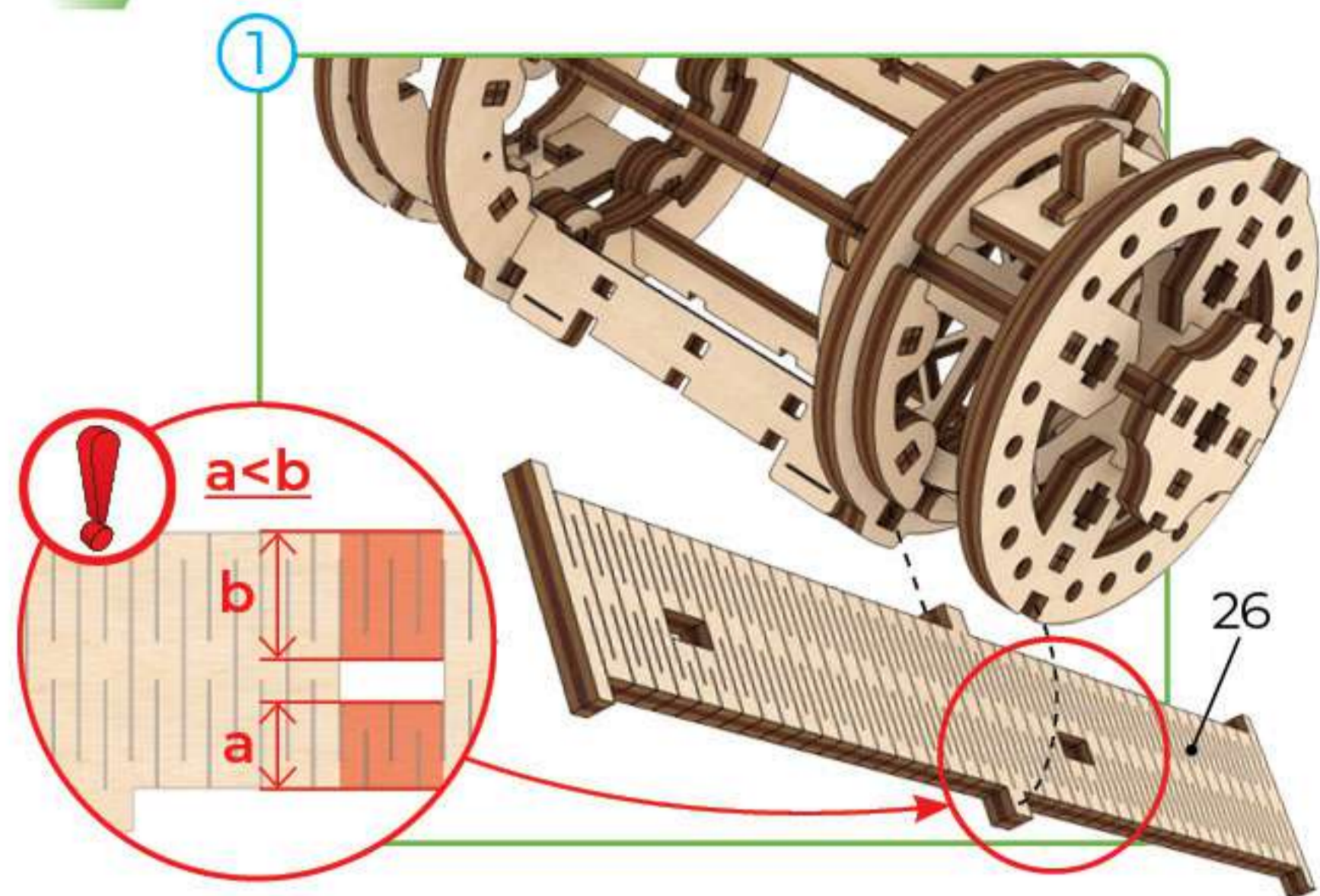

3

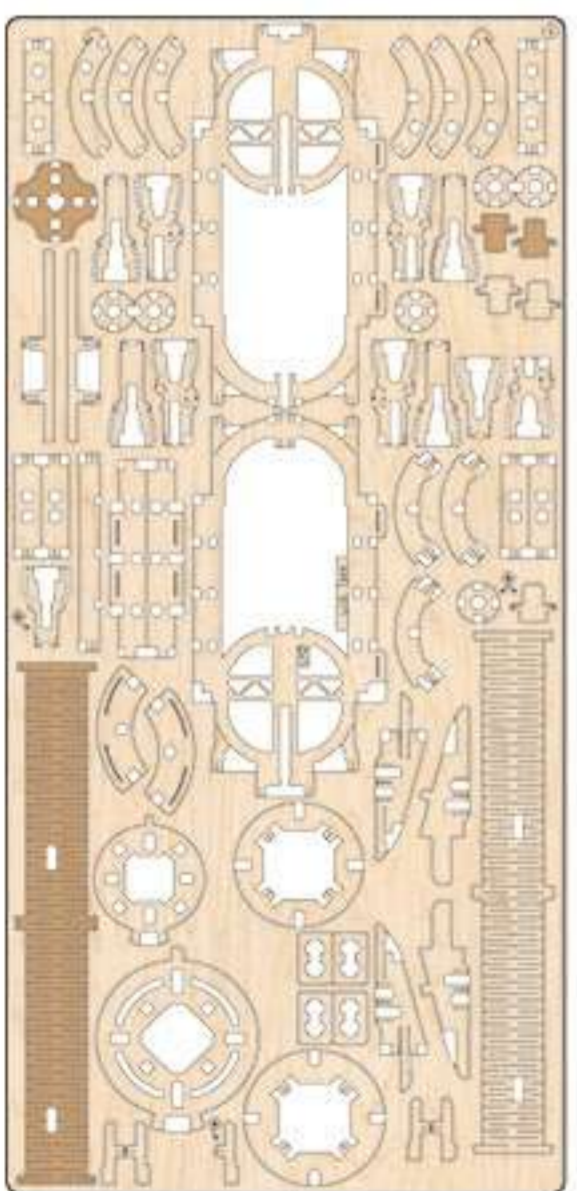

4

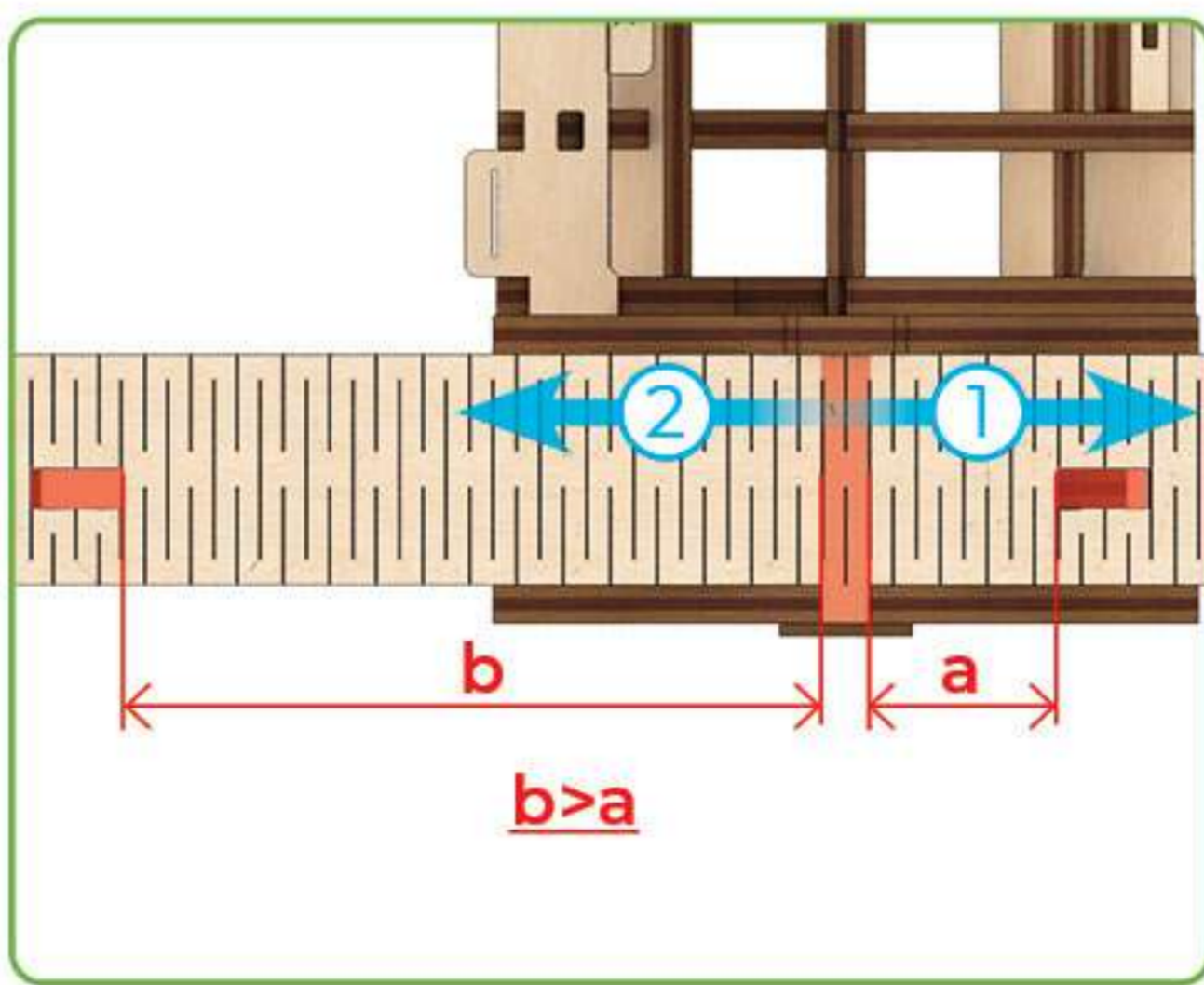
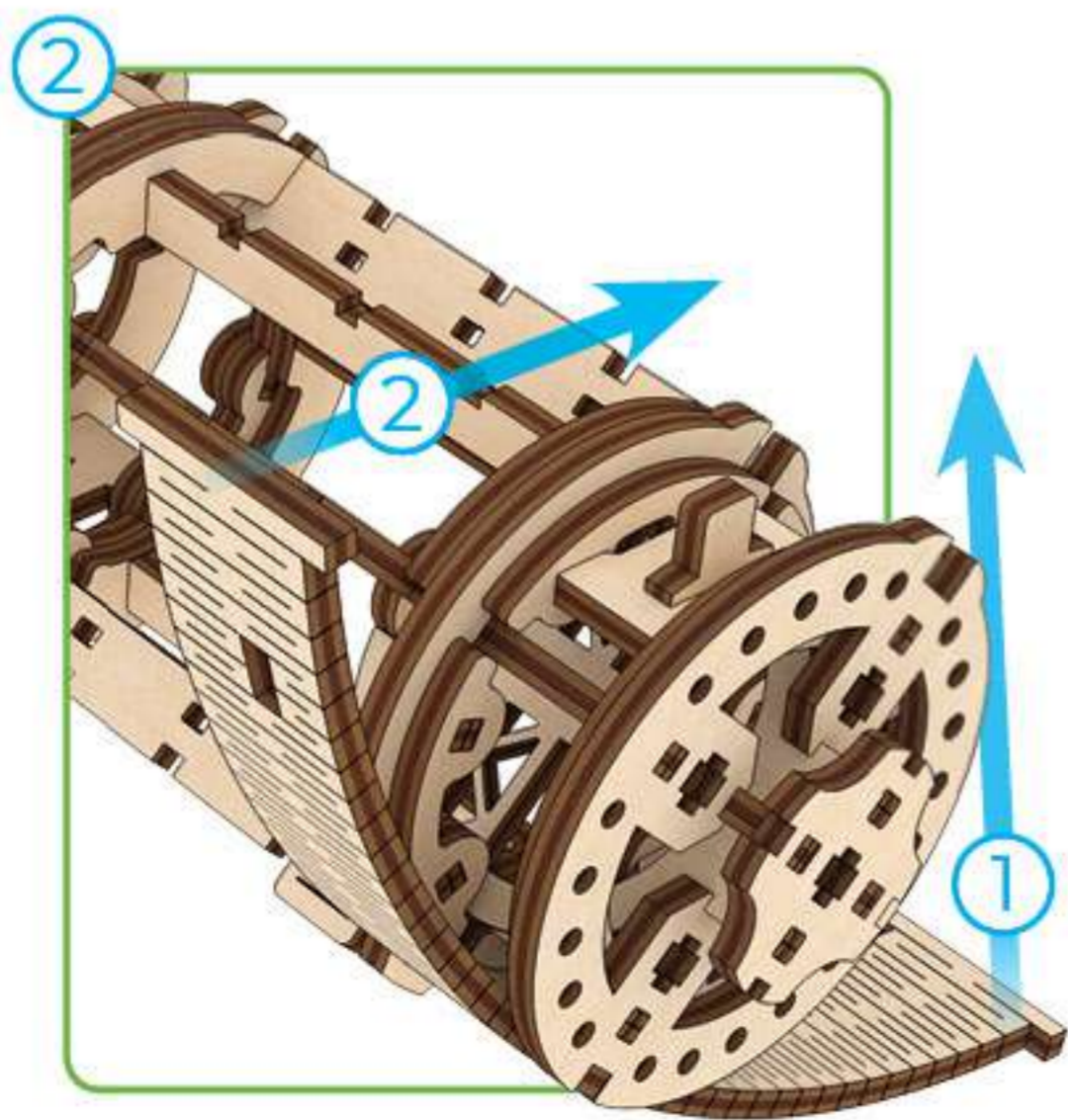

3

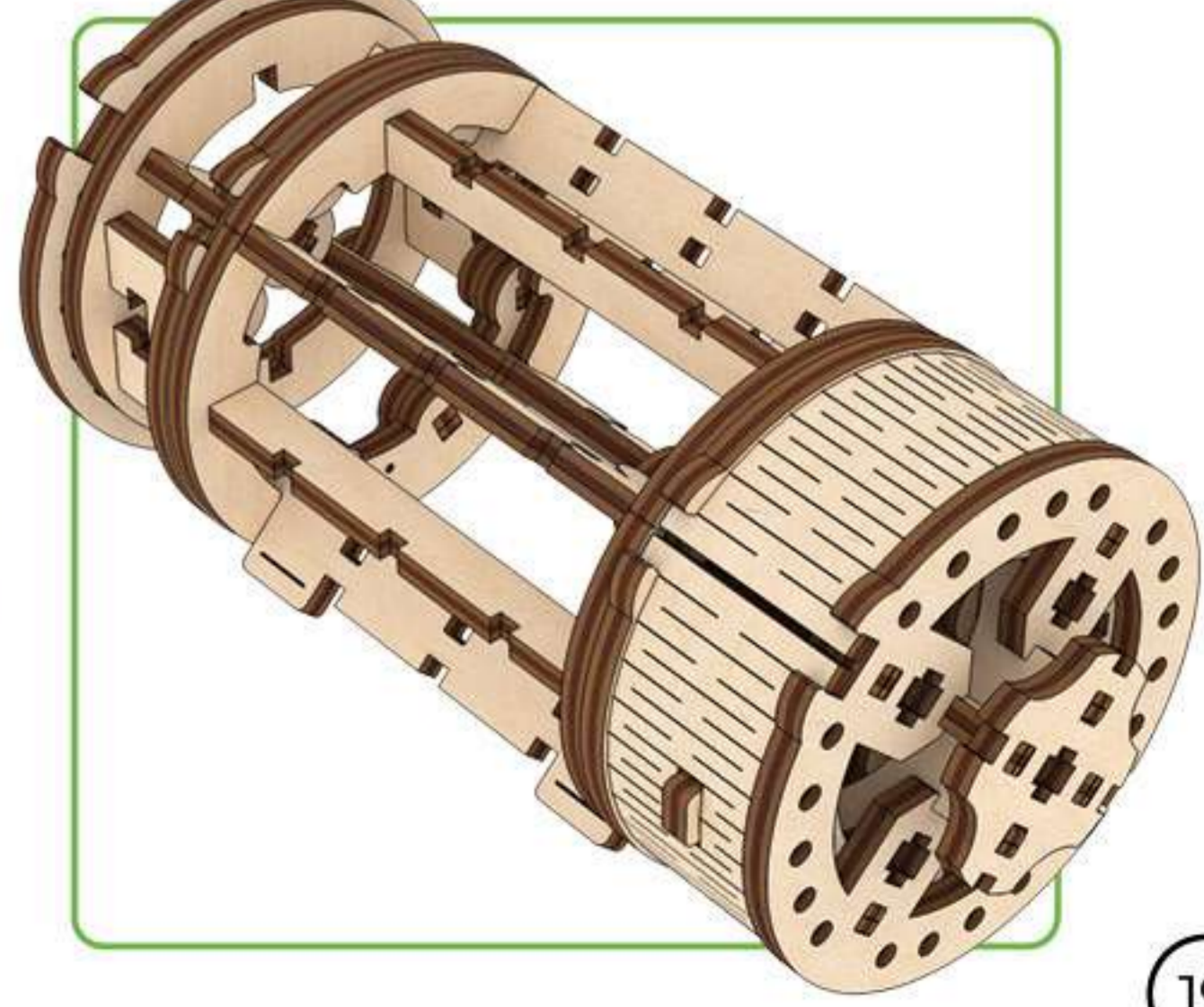
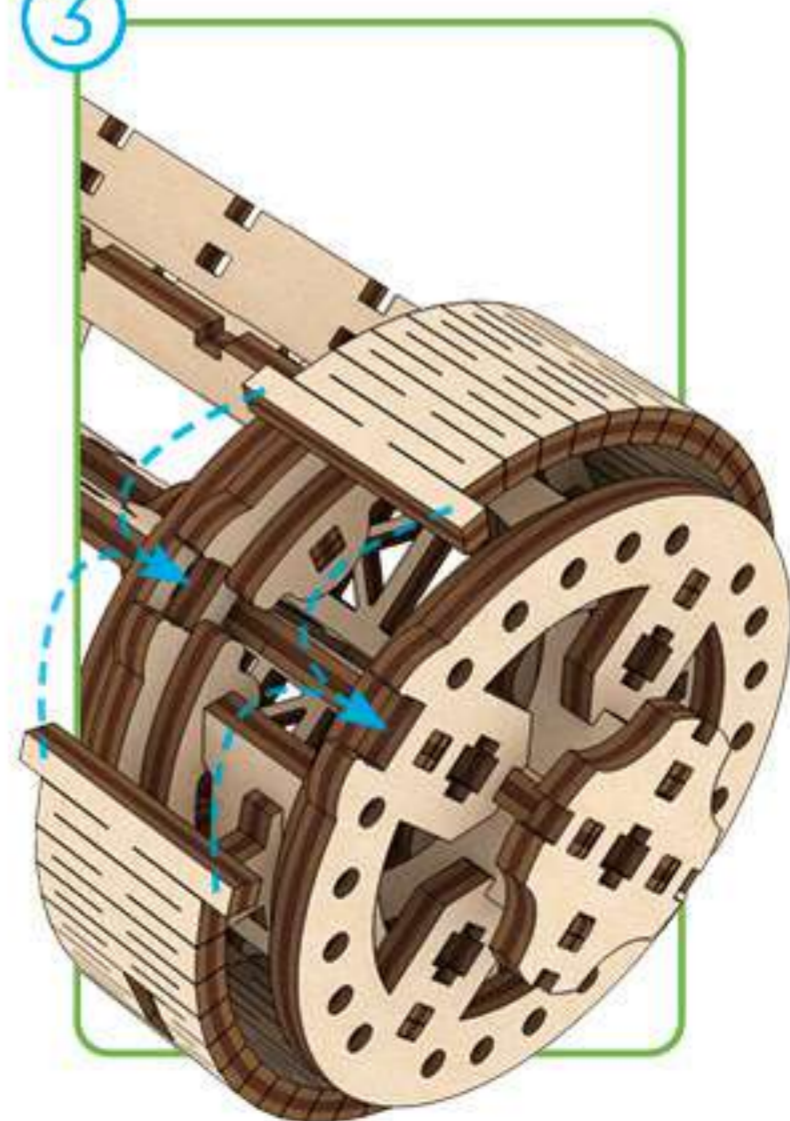

19

10

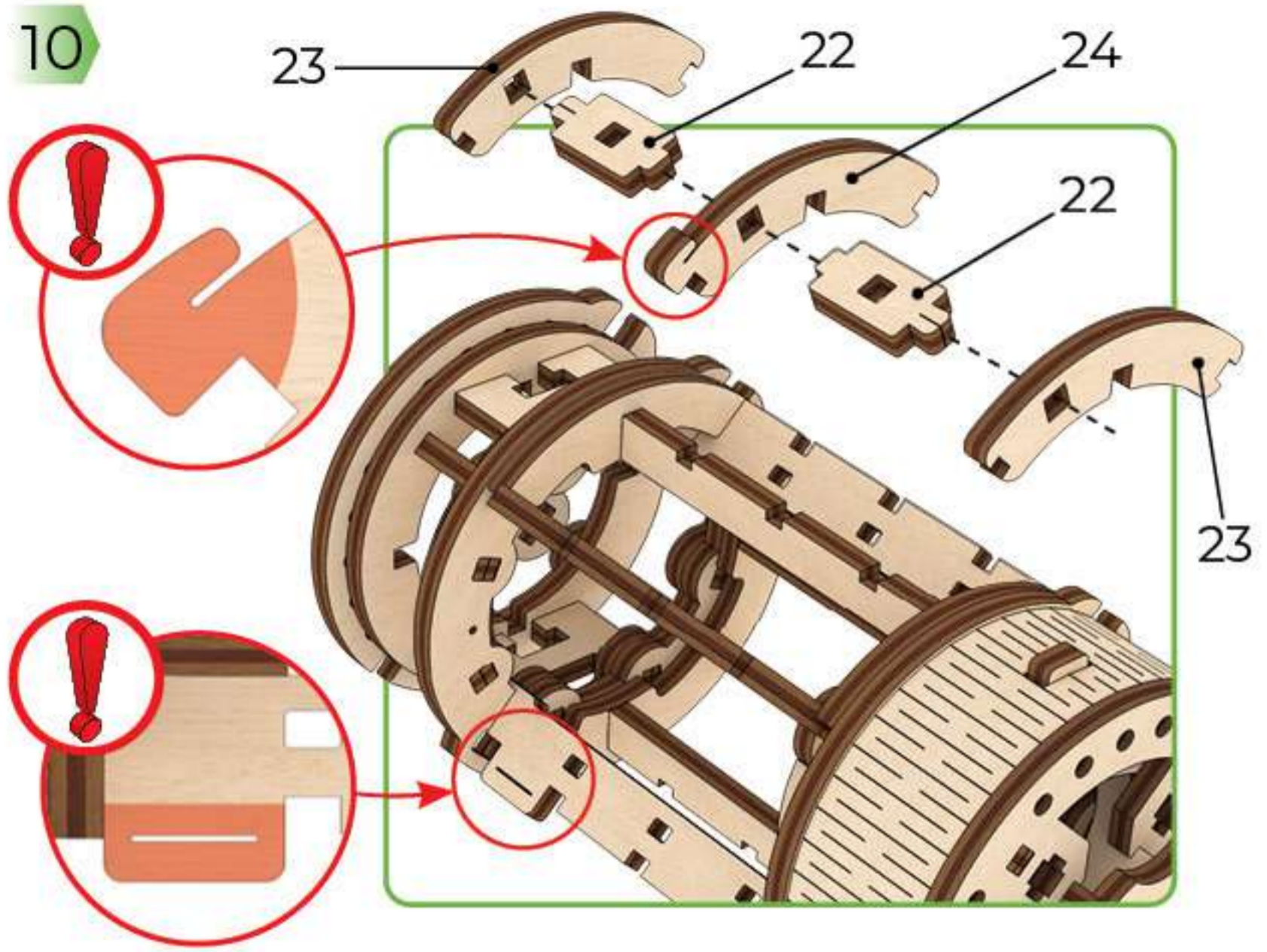

11

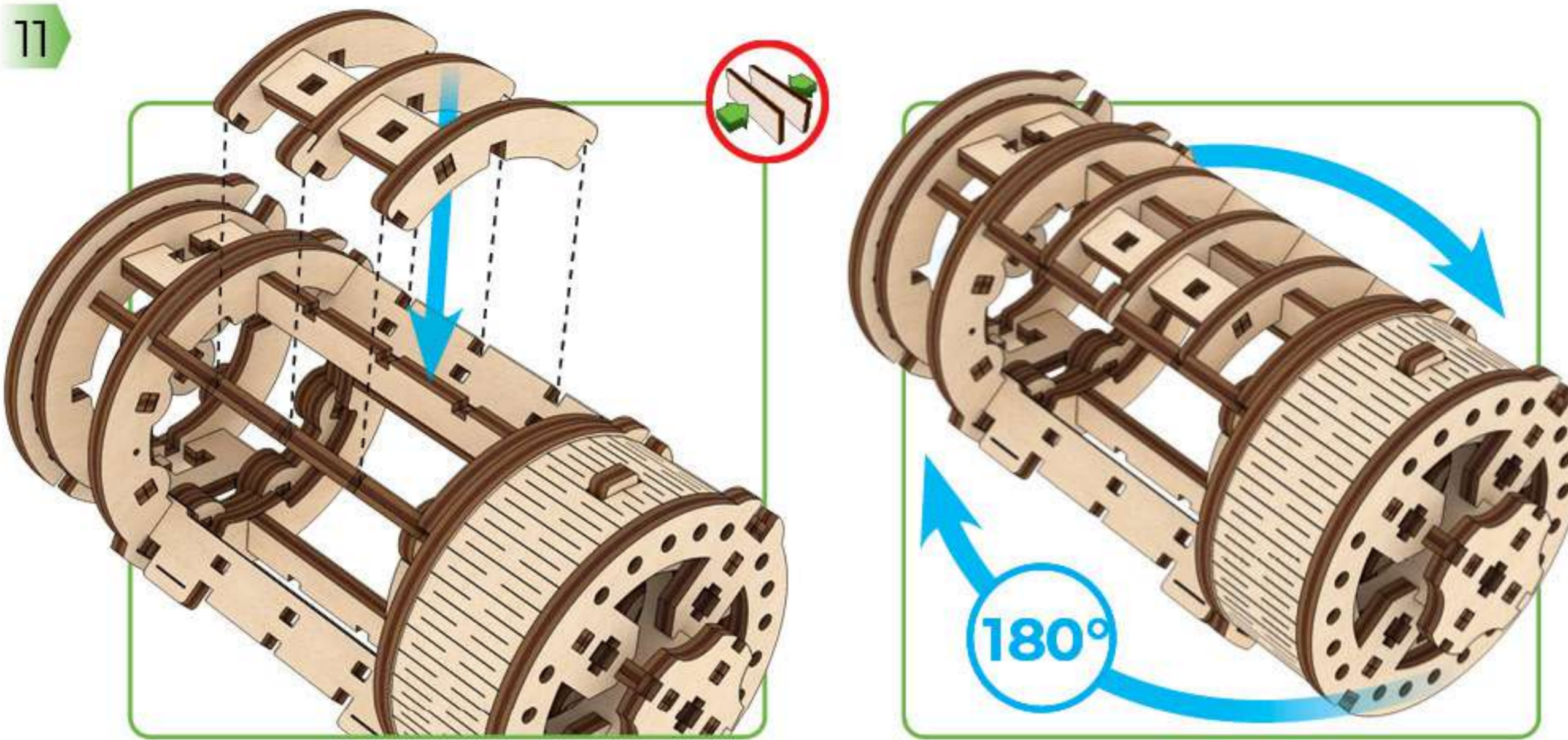

12

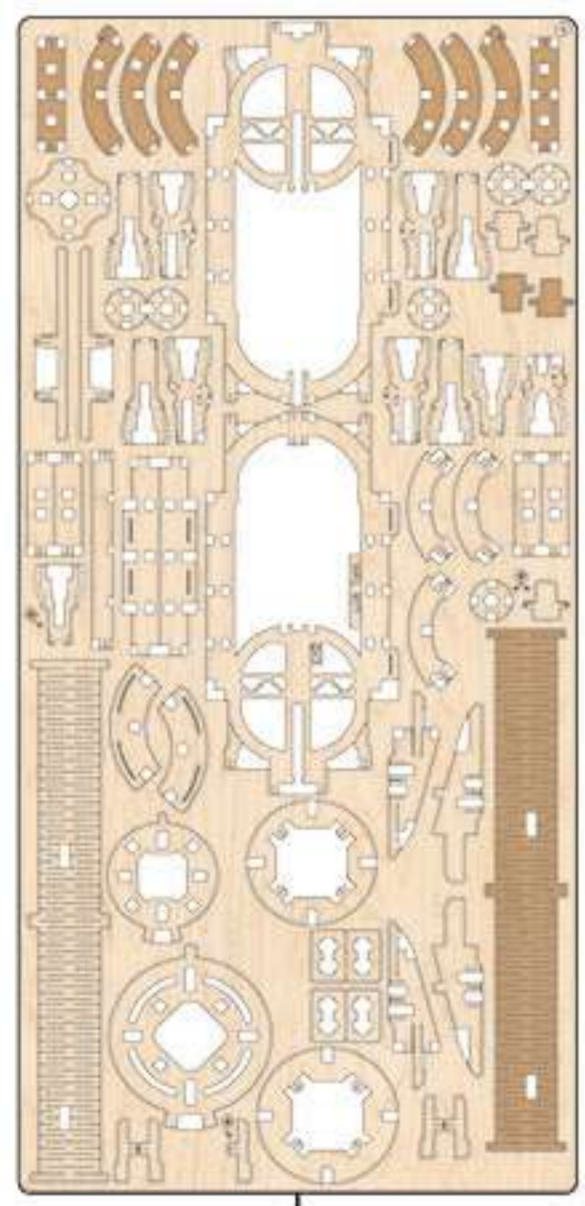
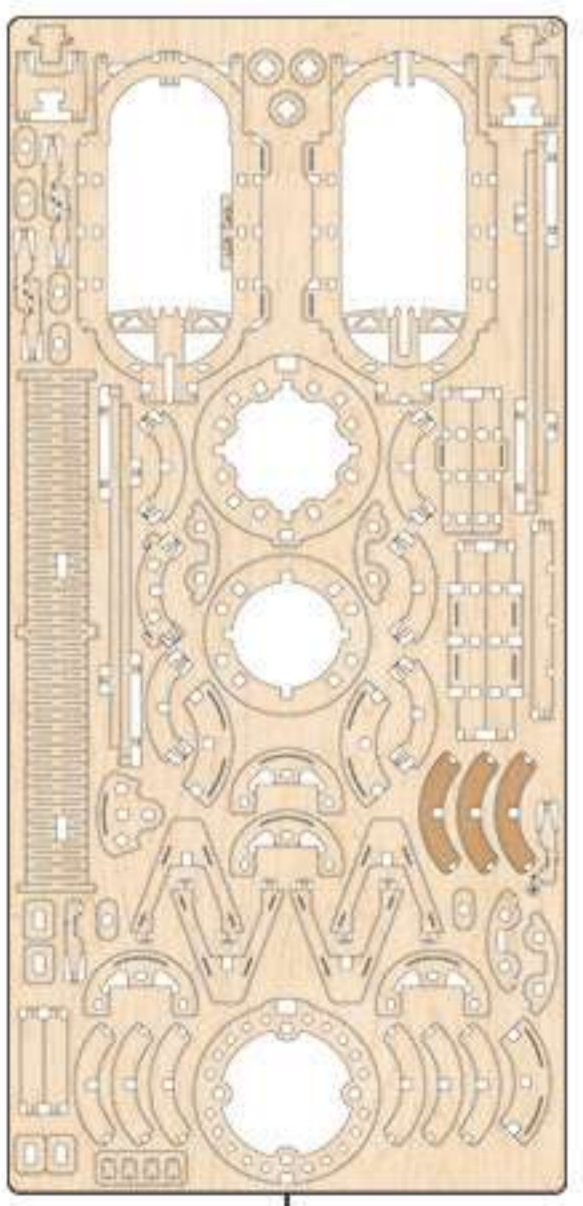
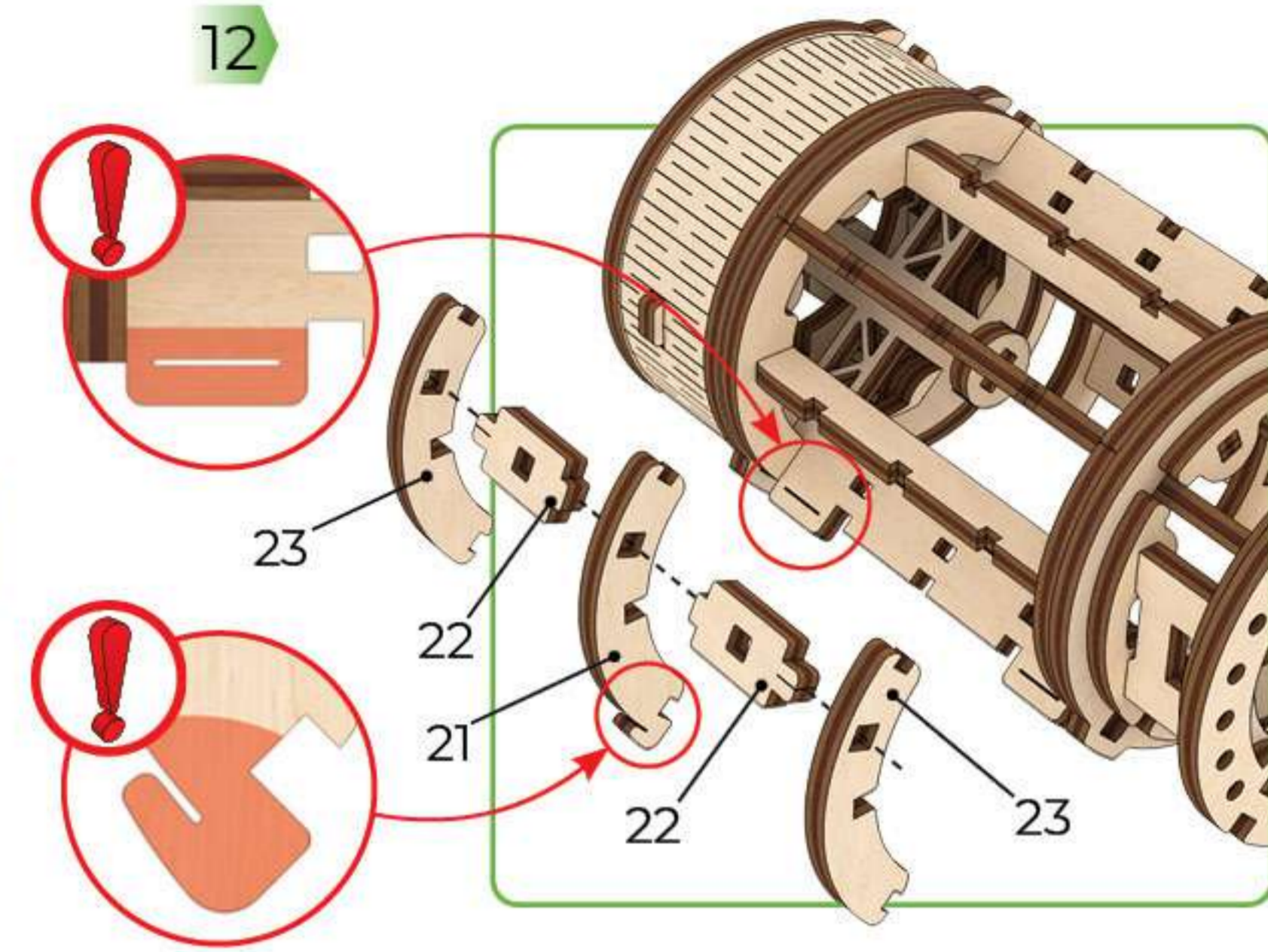

13

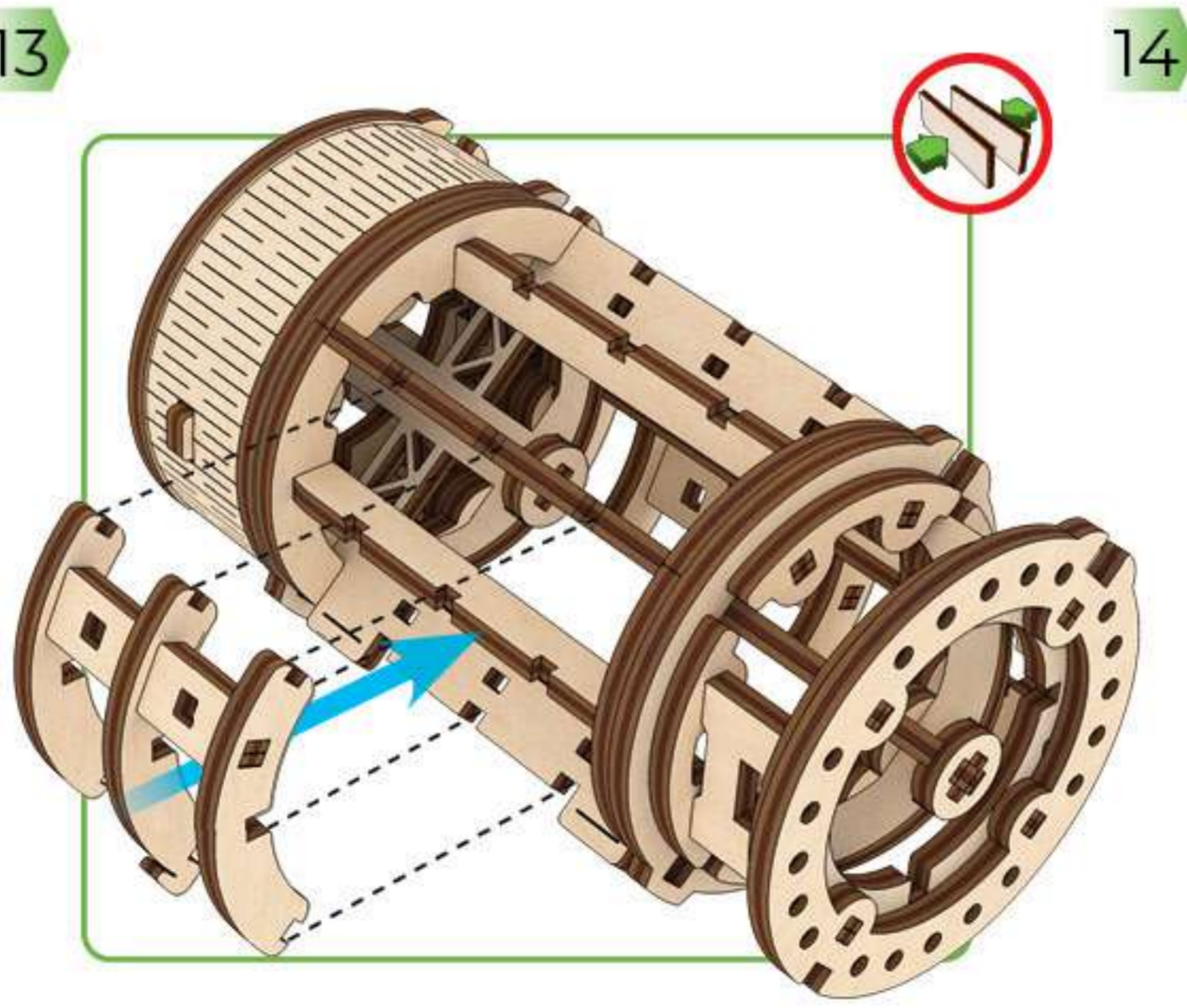

14

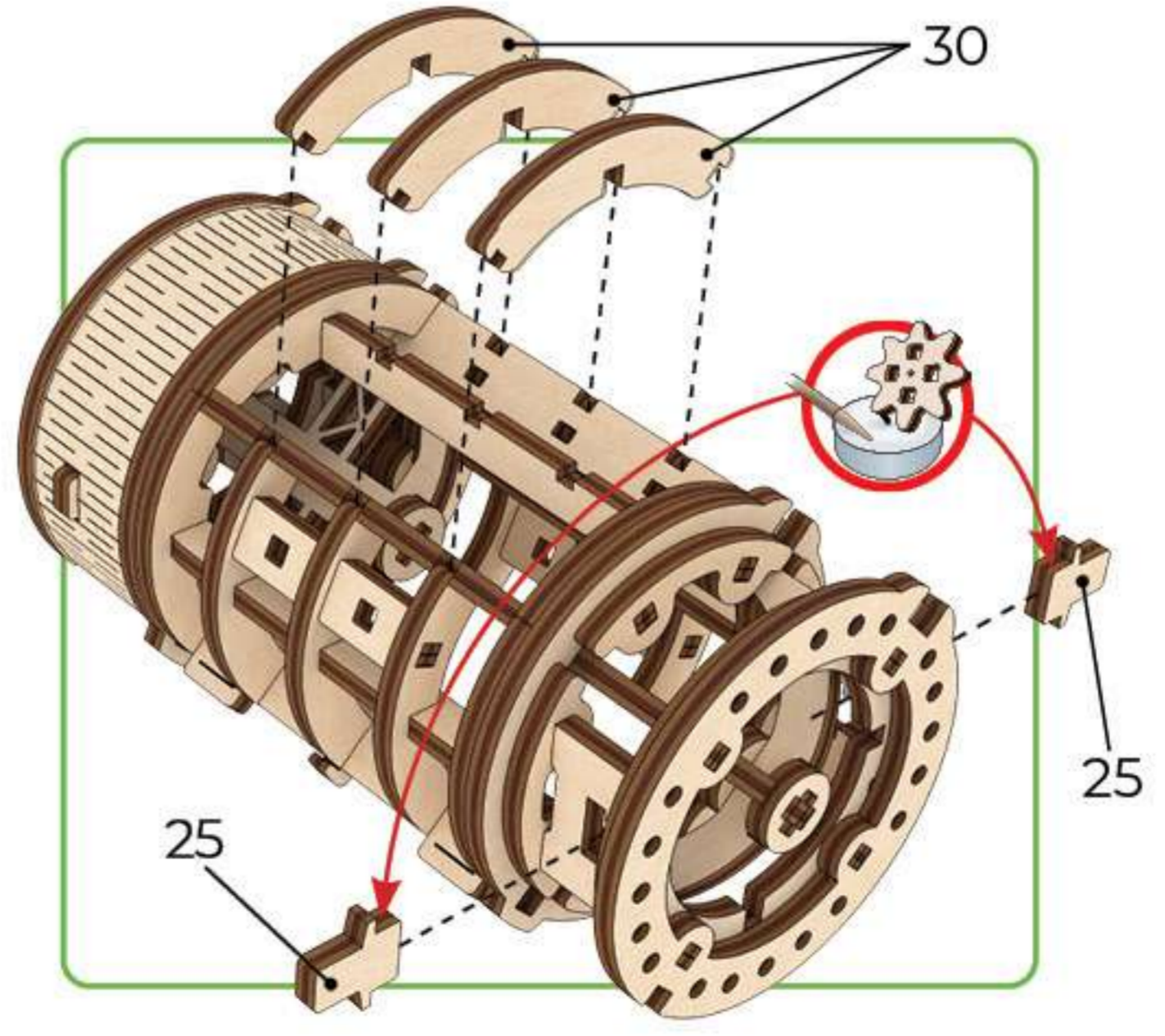

15

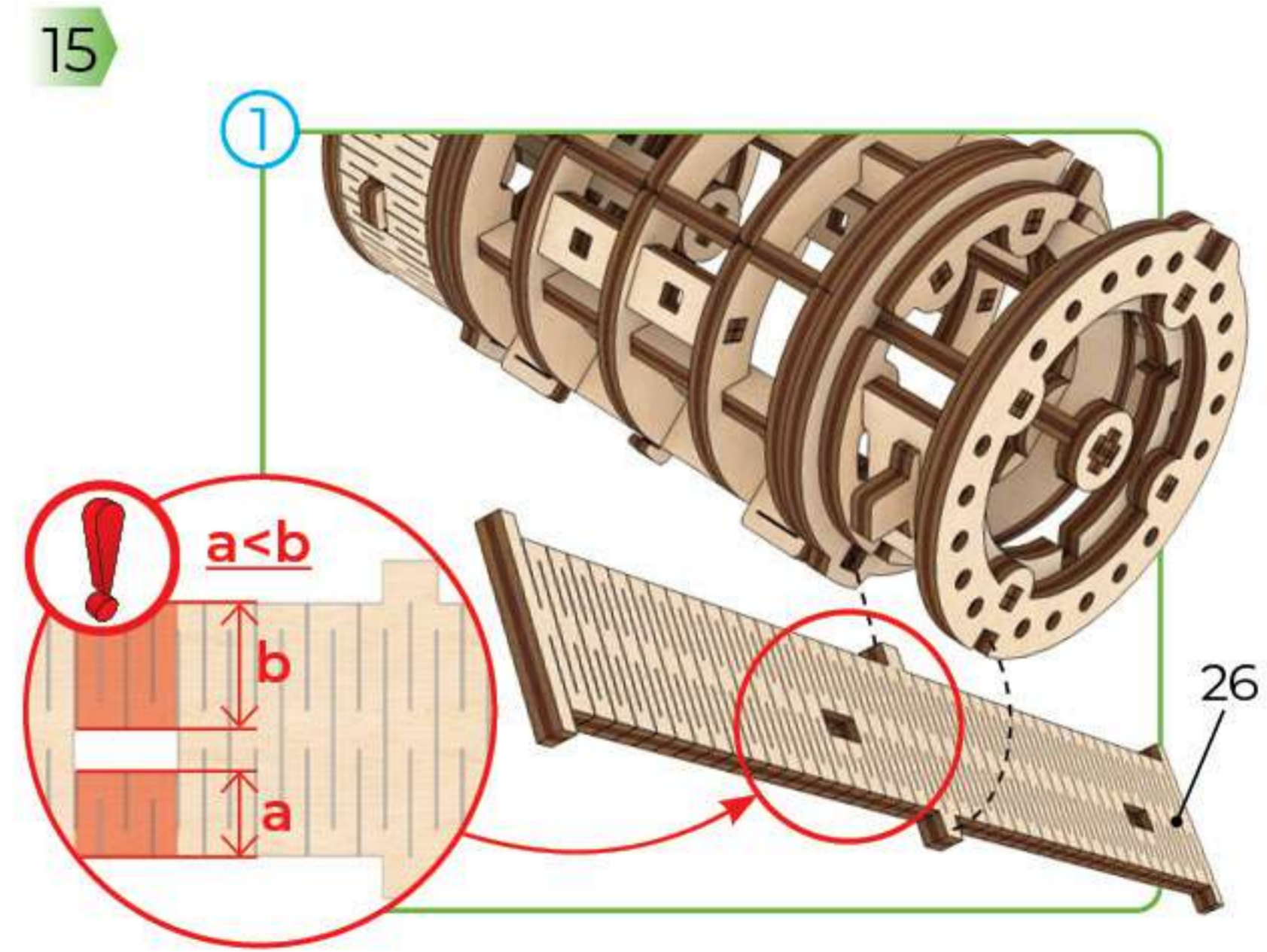

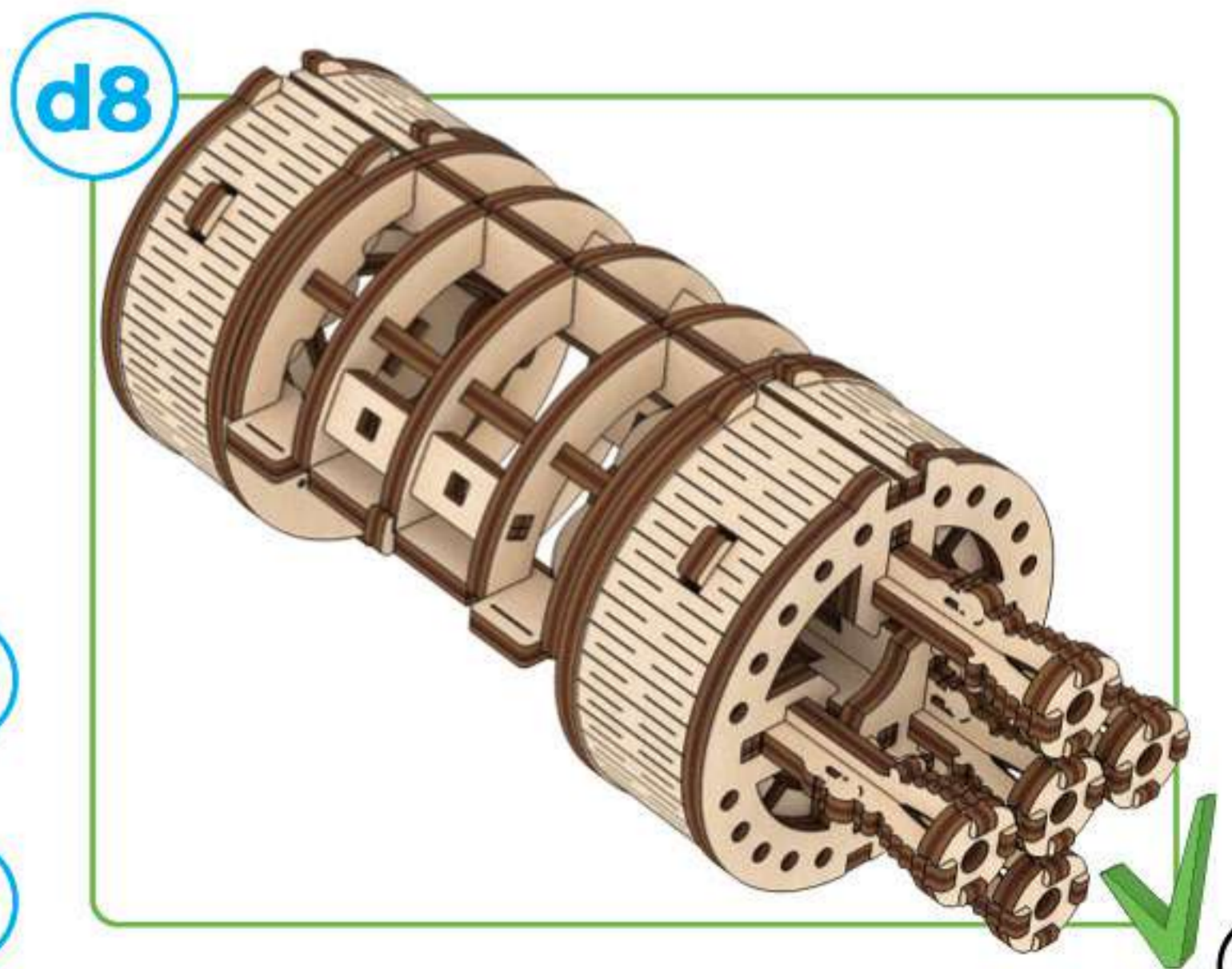
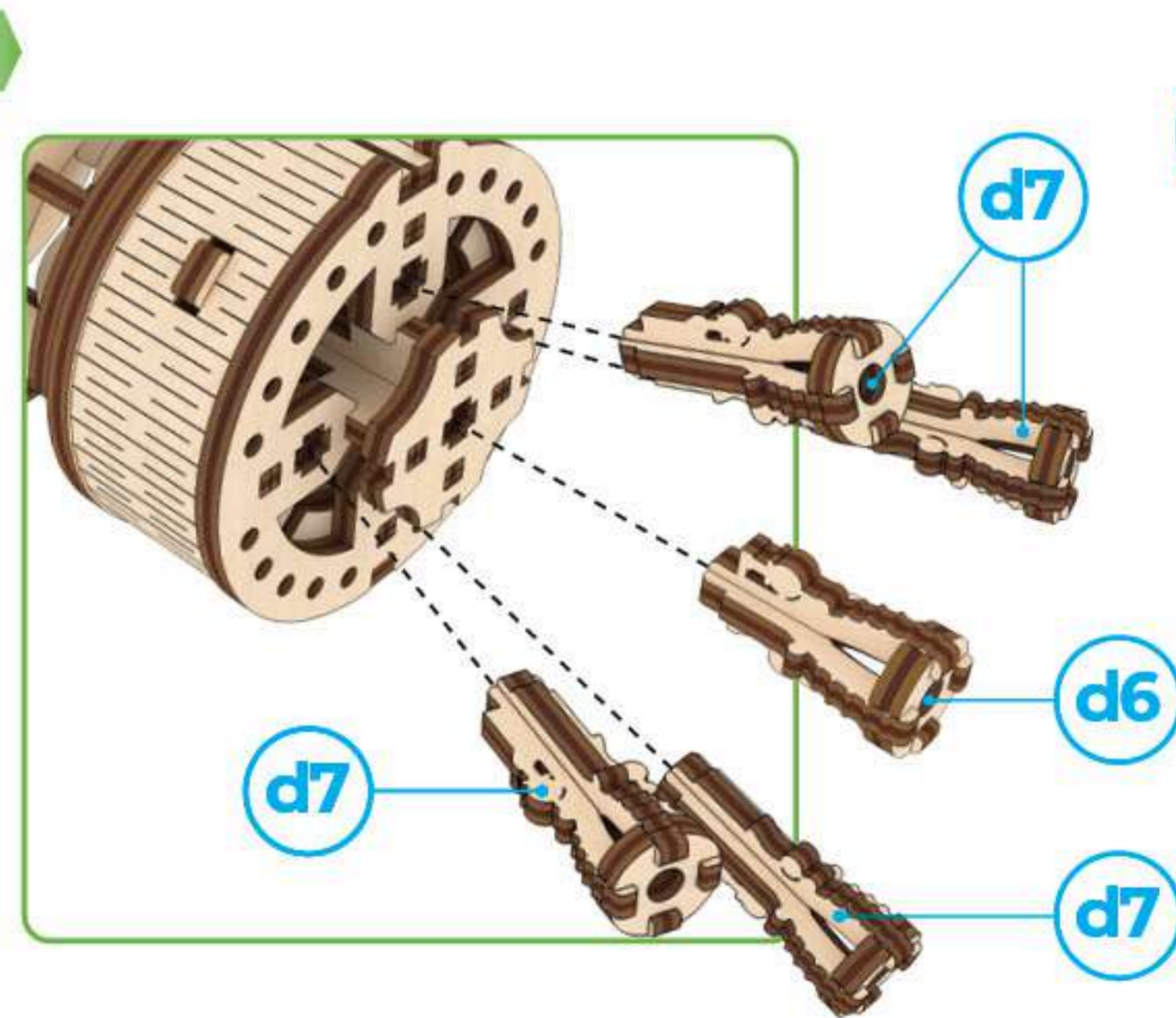
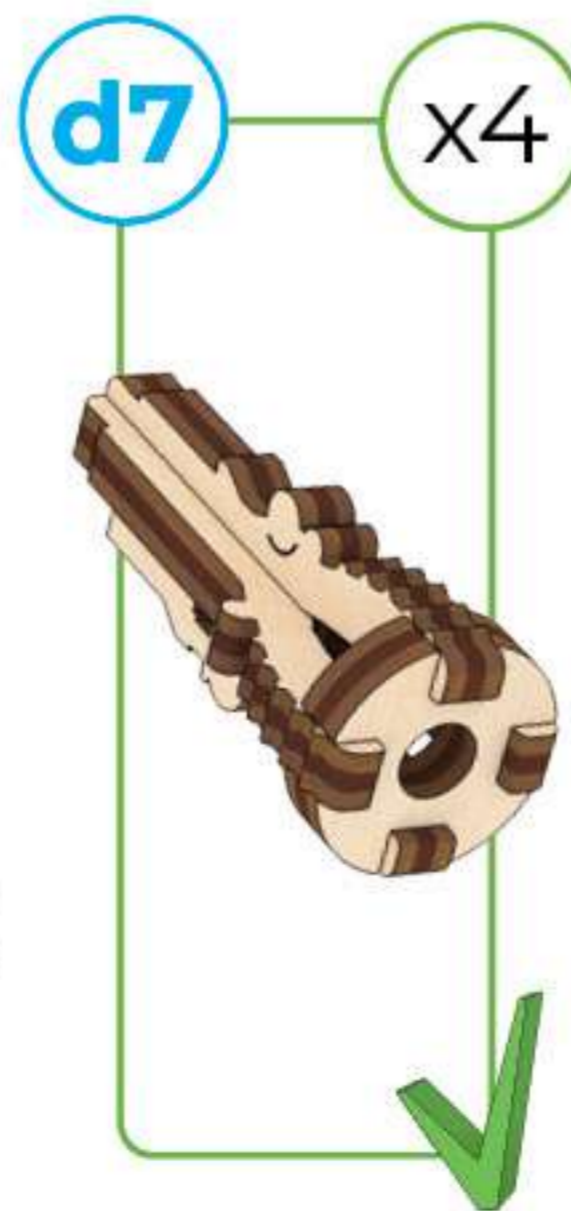
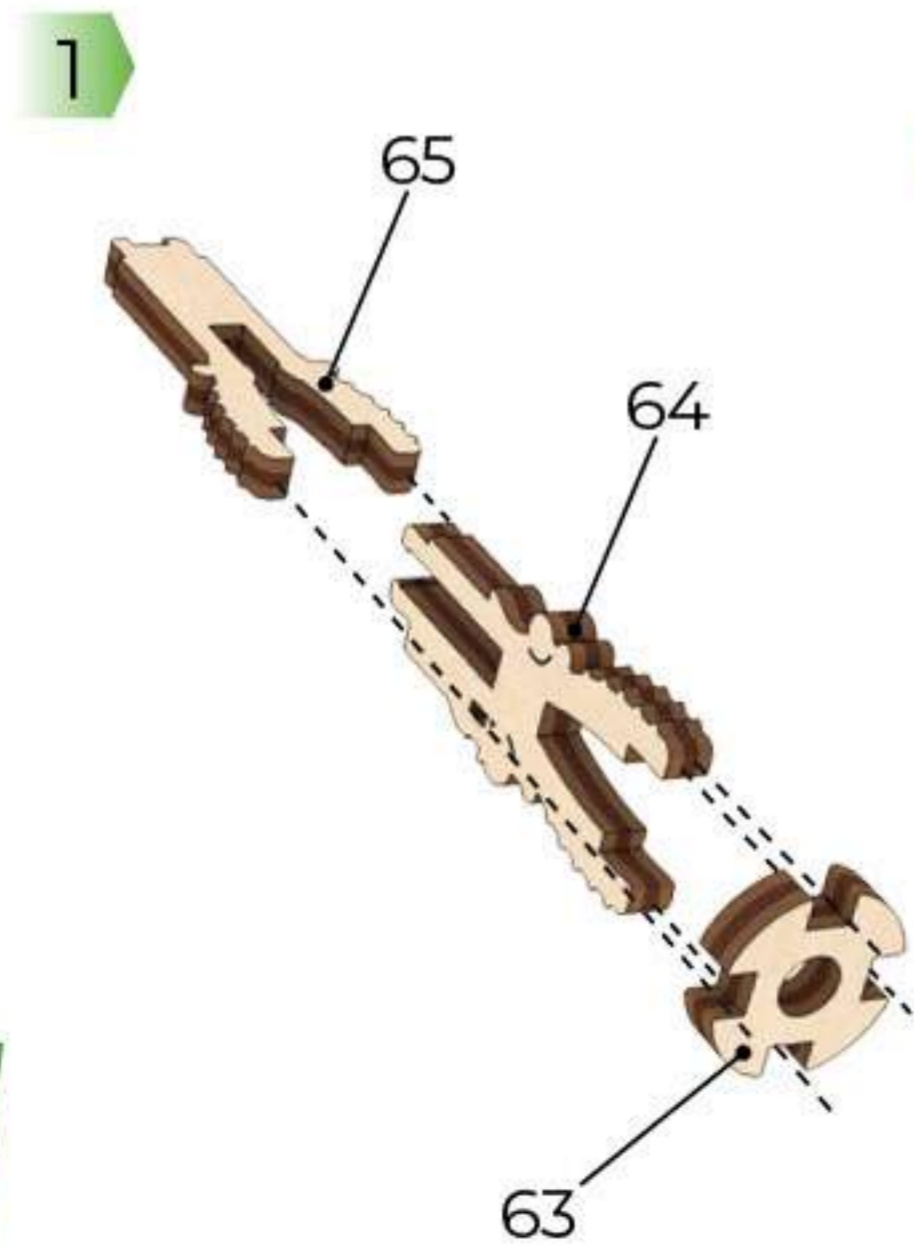
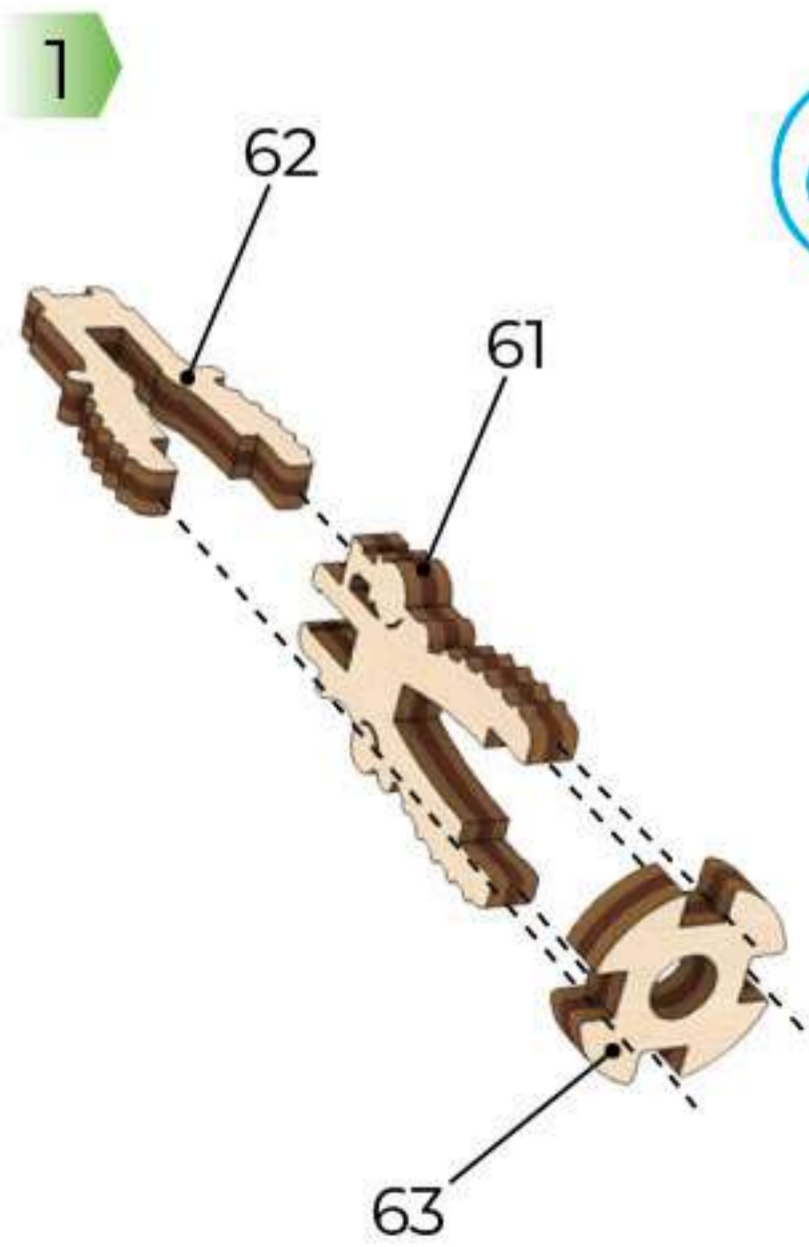
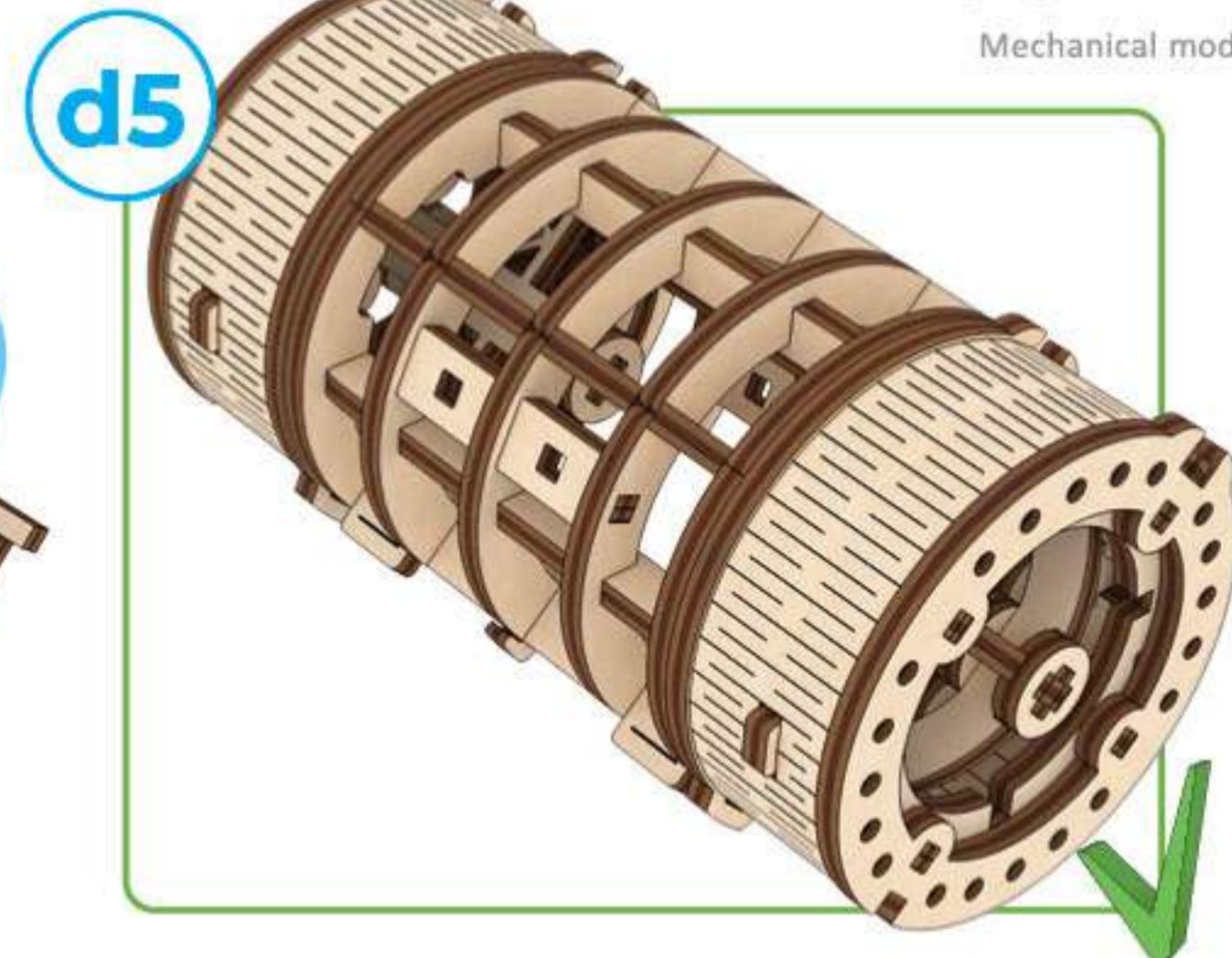
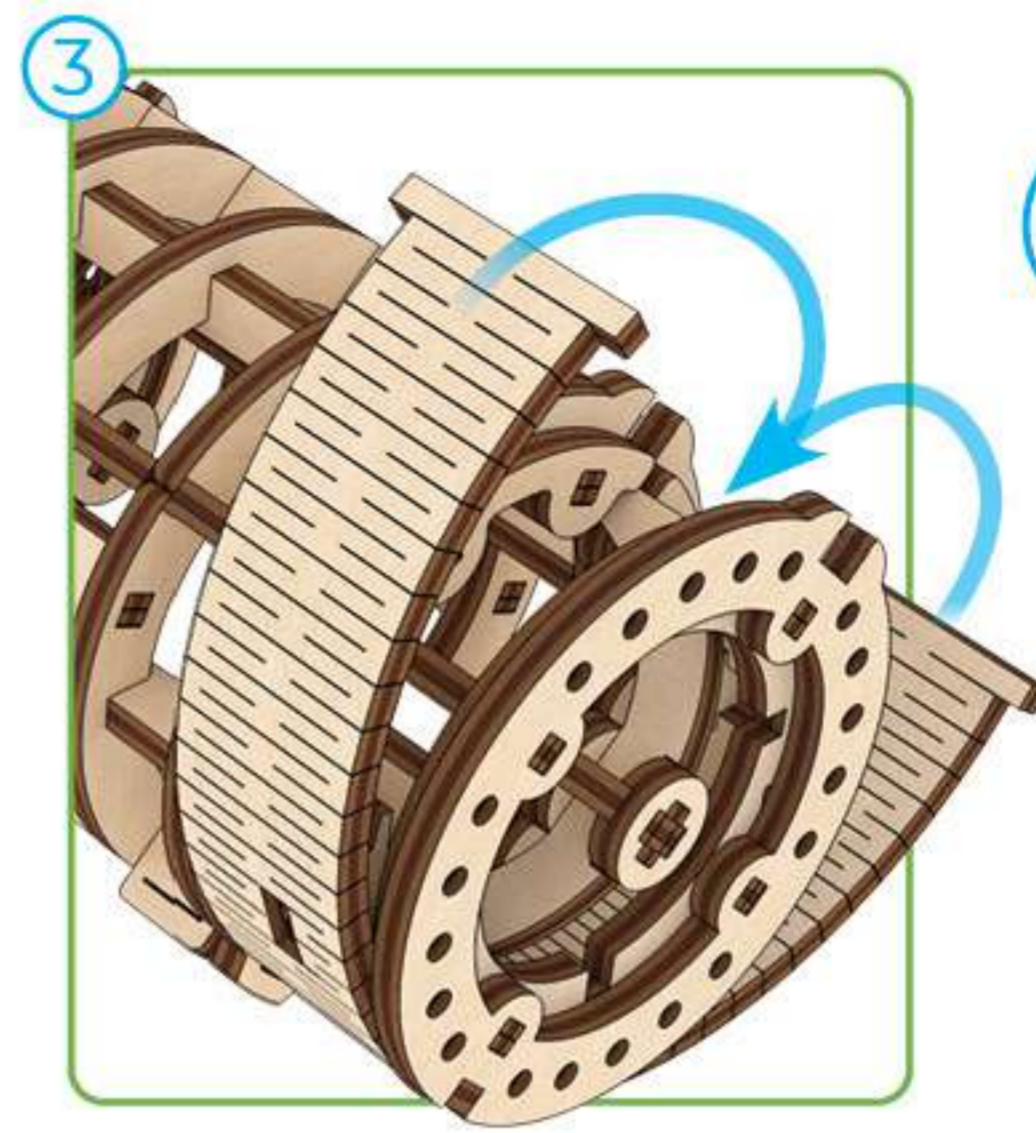
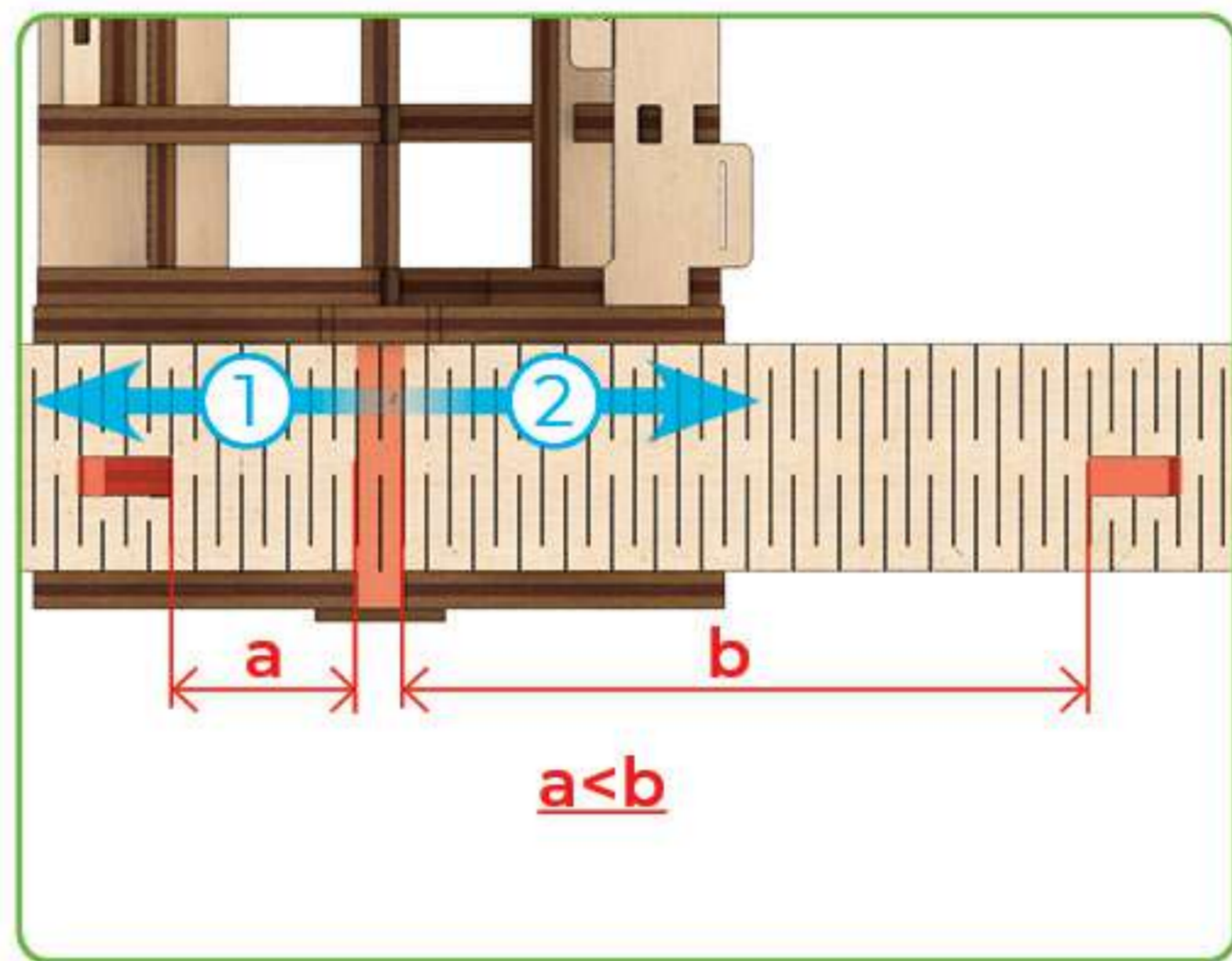
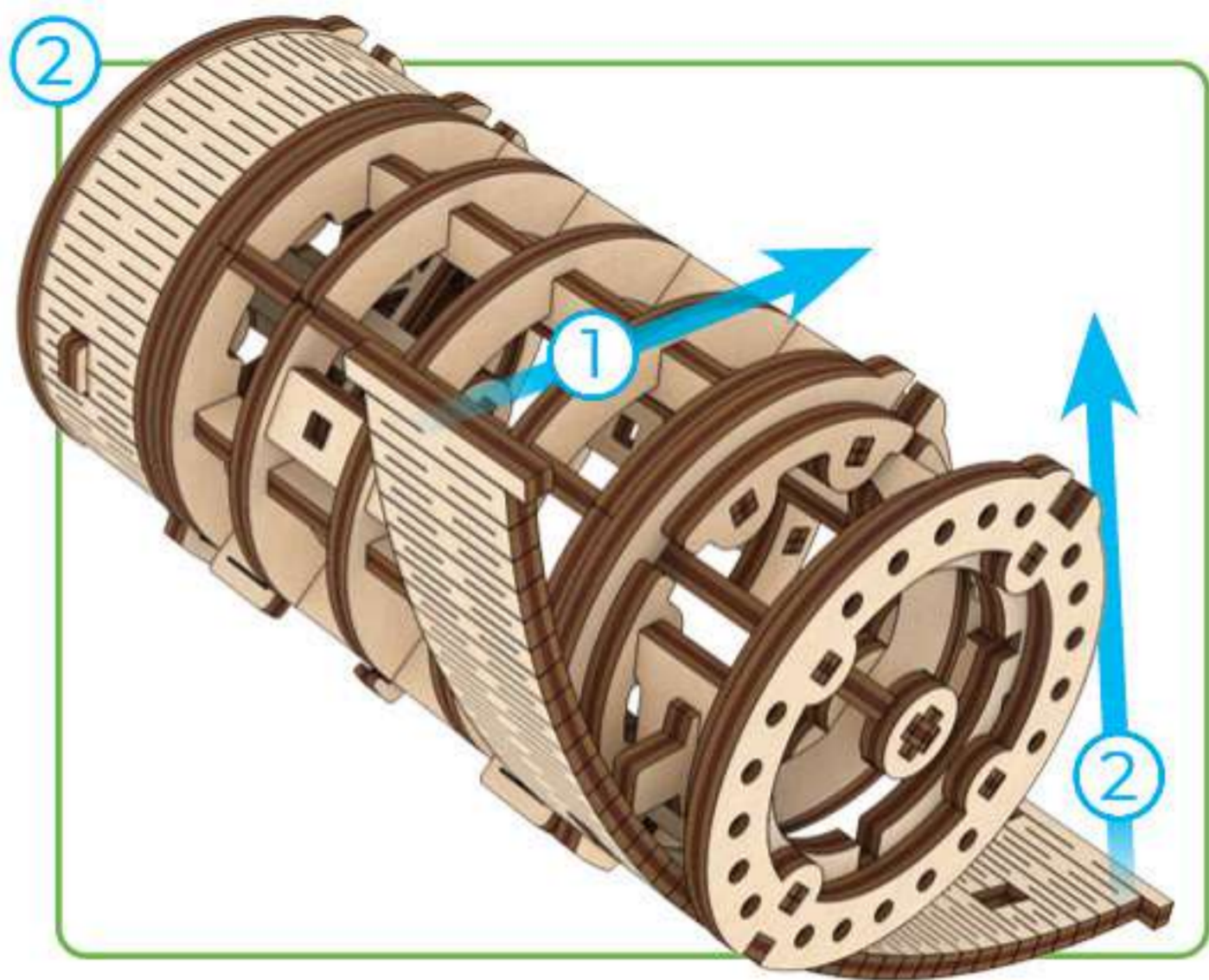
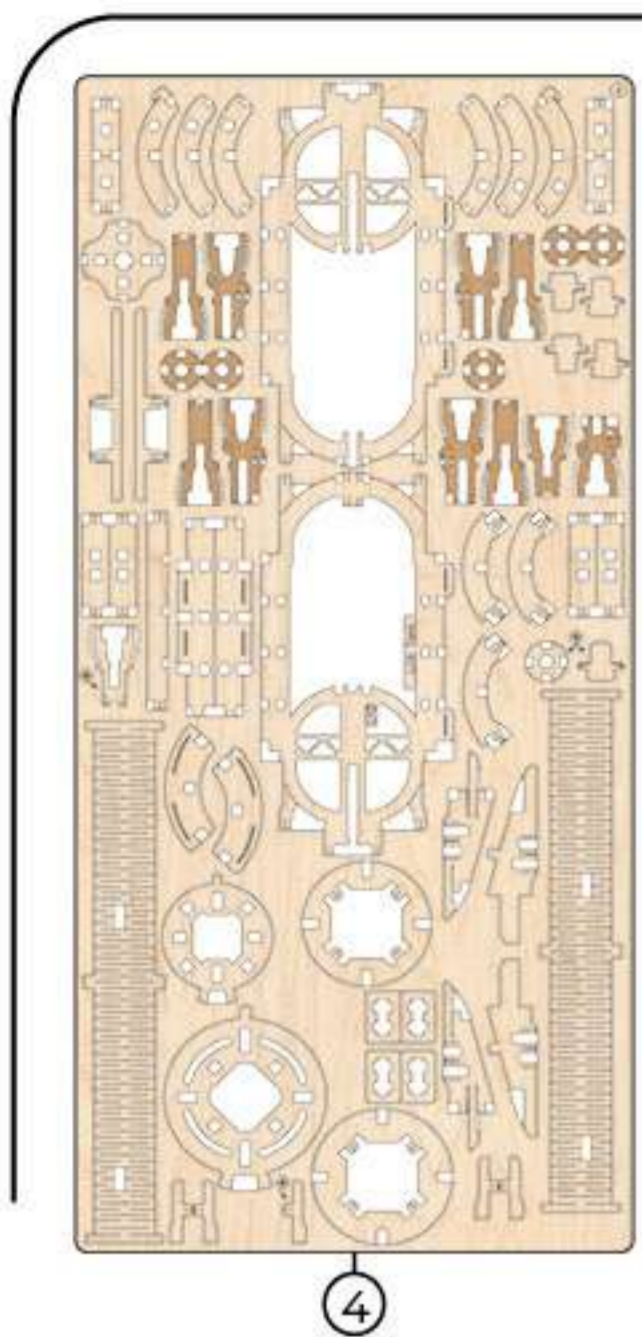

Mechanical models

1

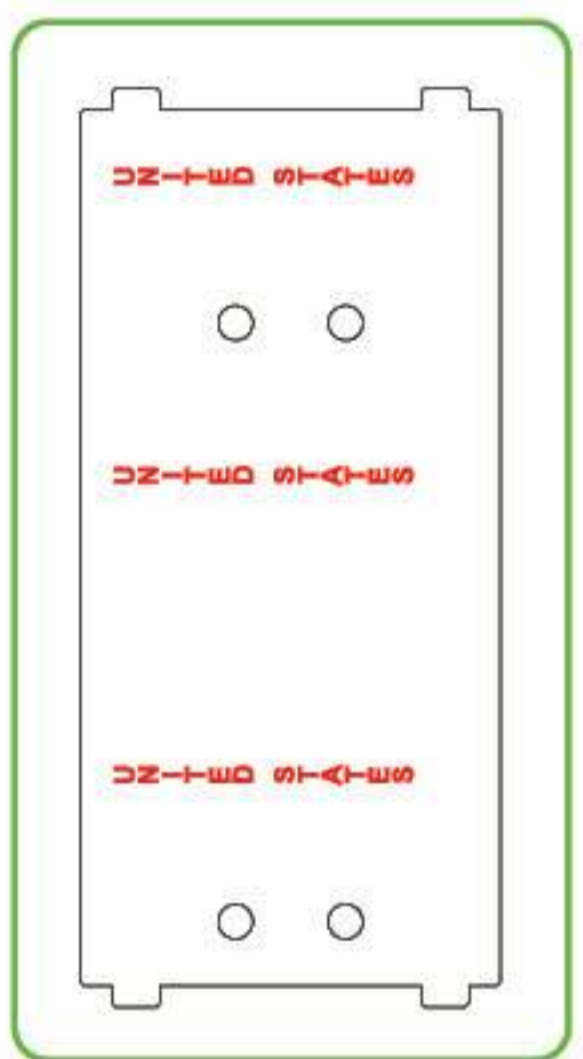

1

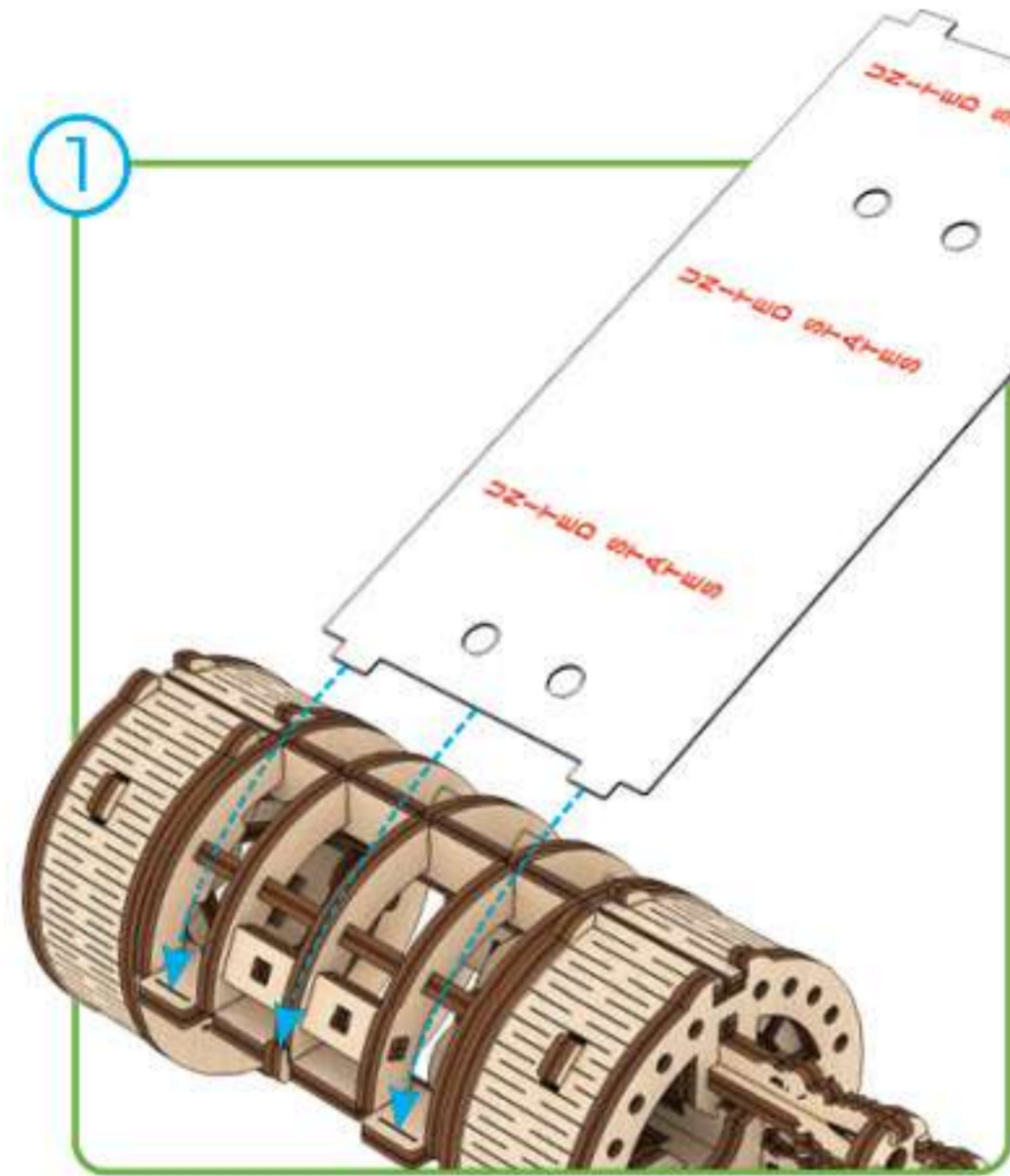

2

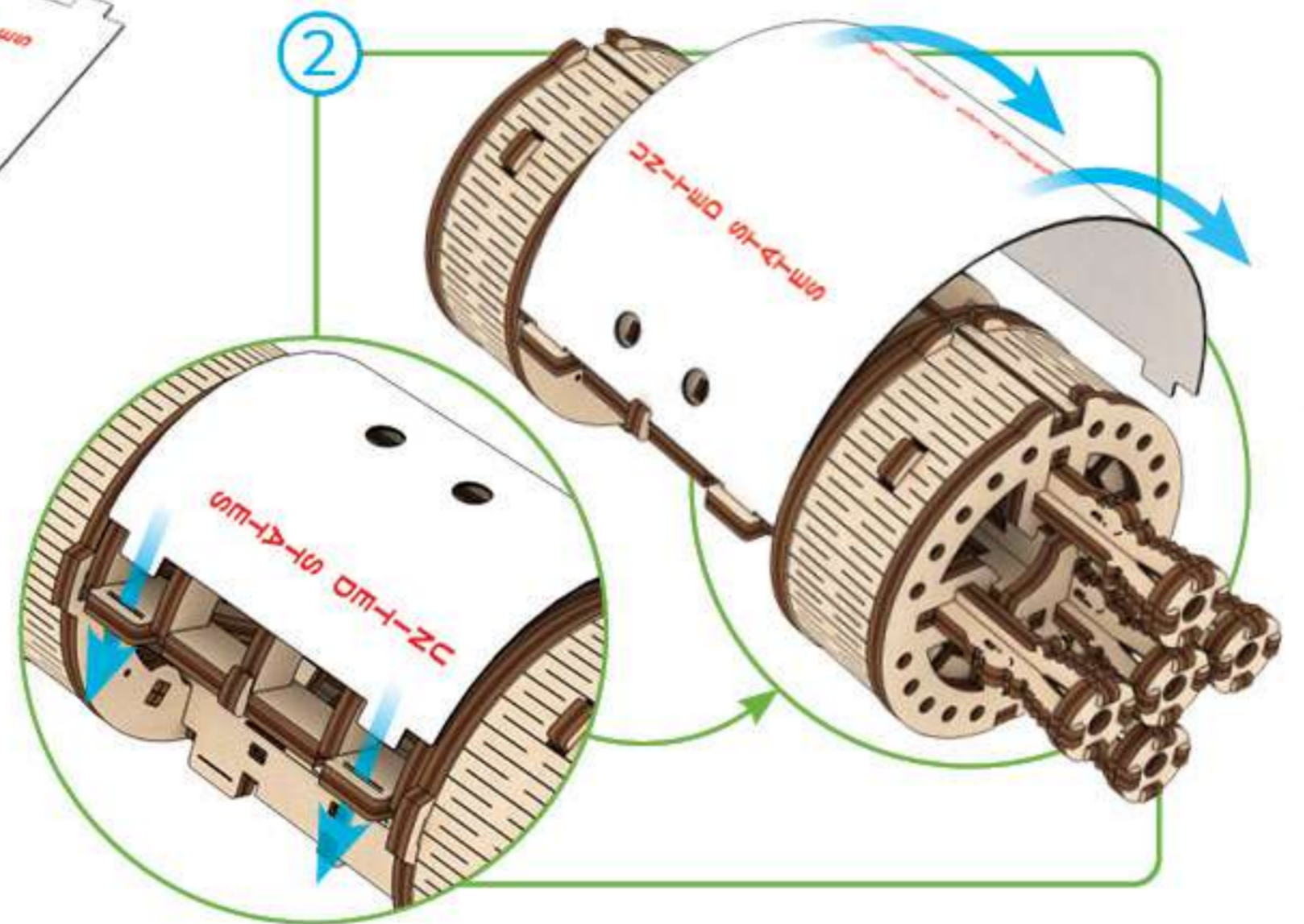

3

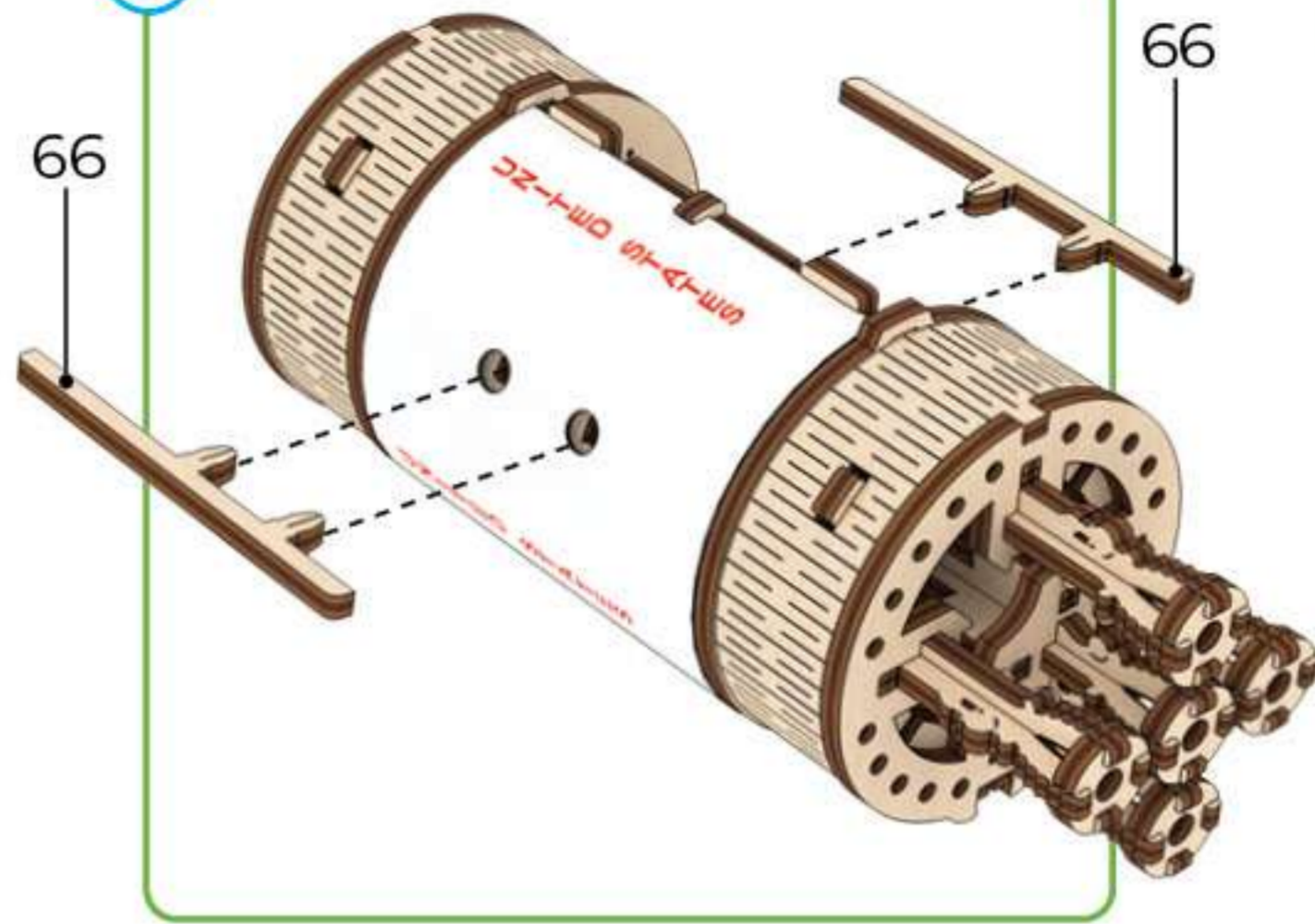

d9

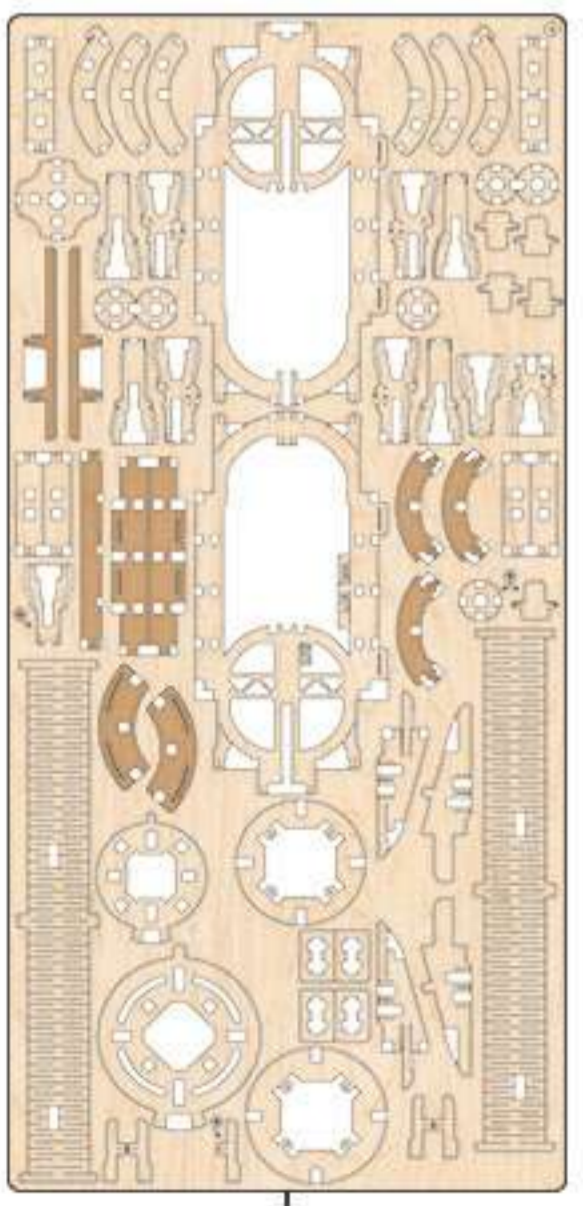
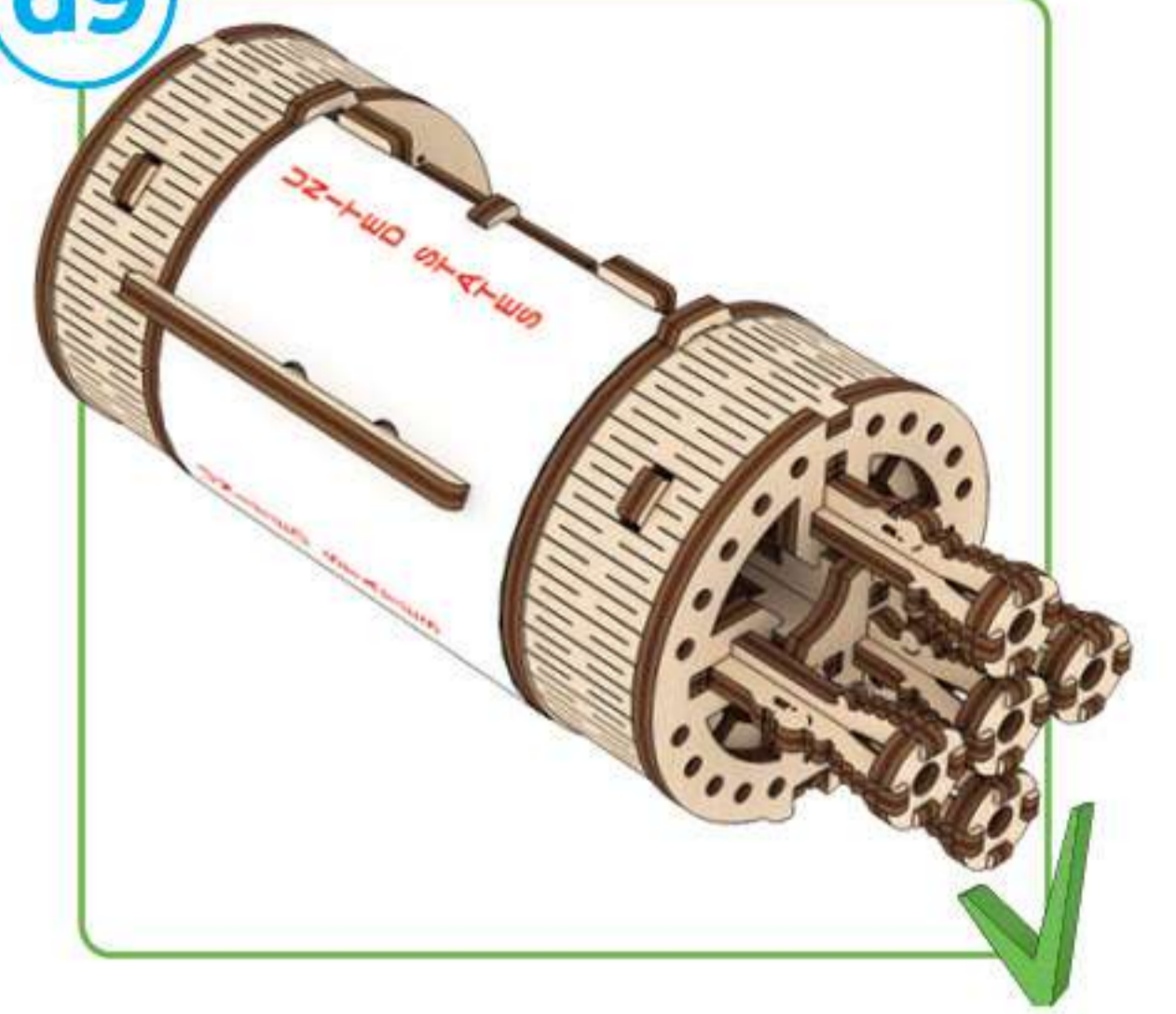

1

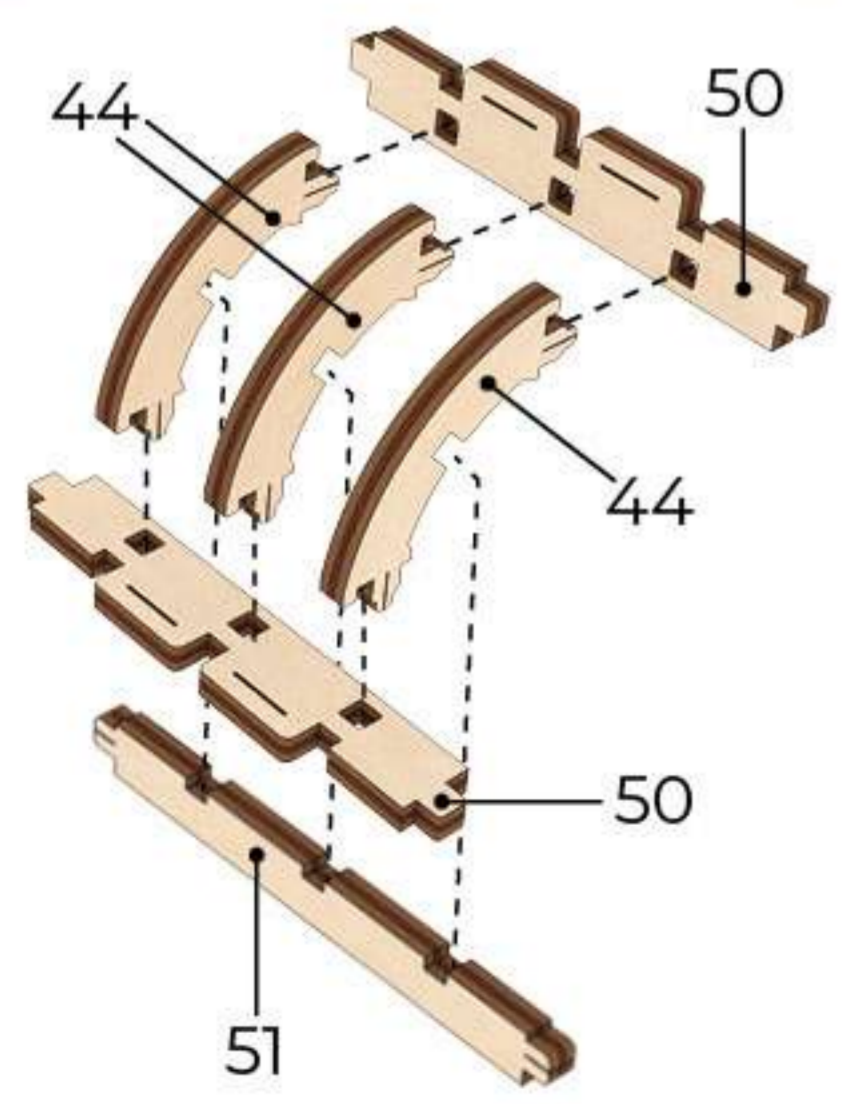

2

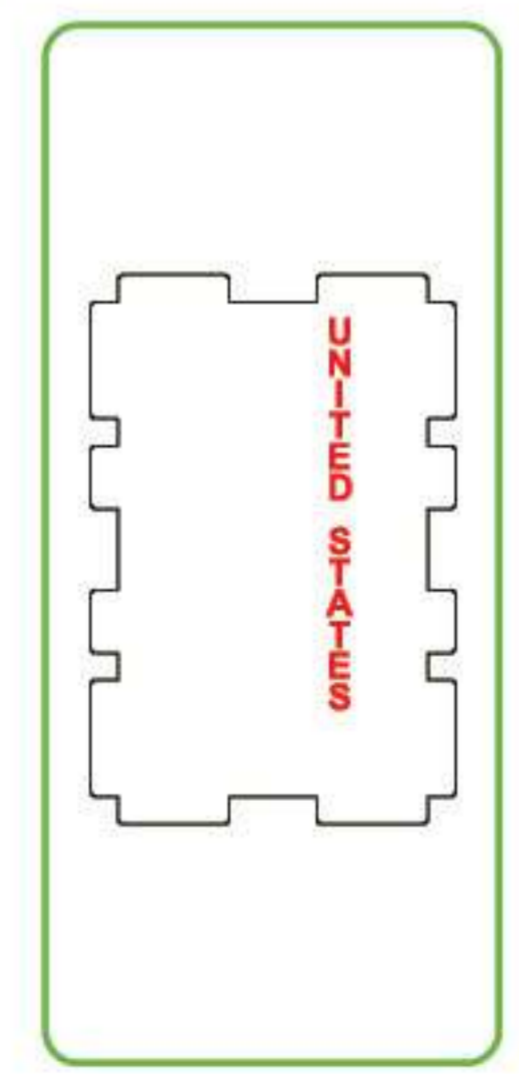

3

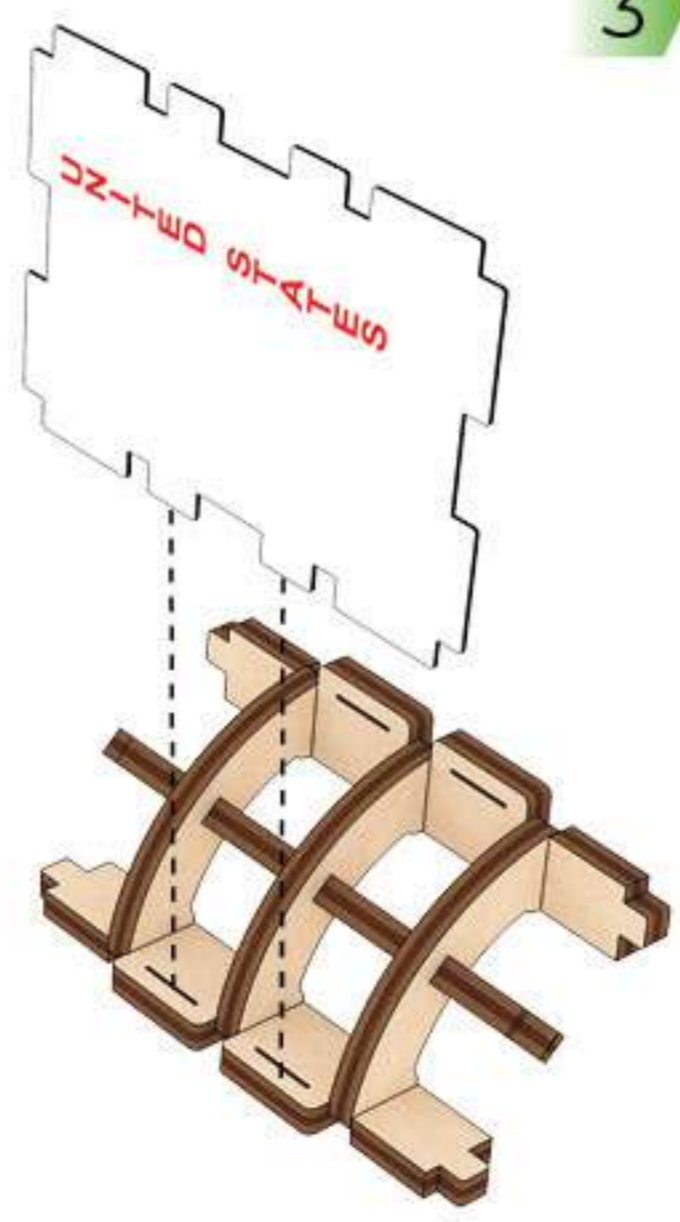

4

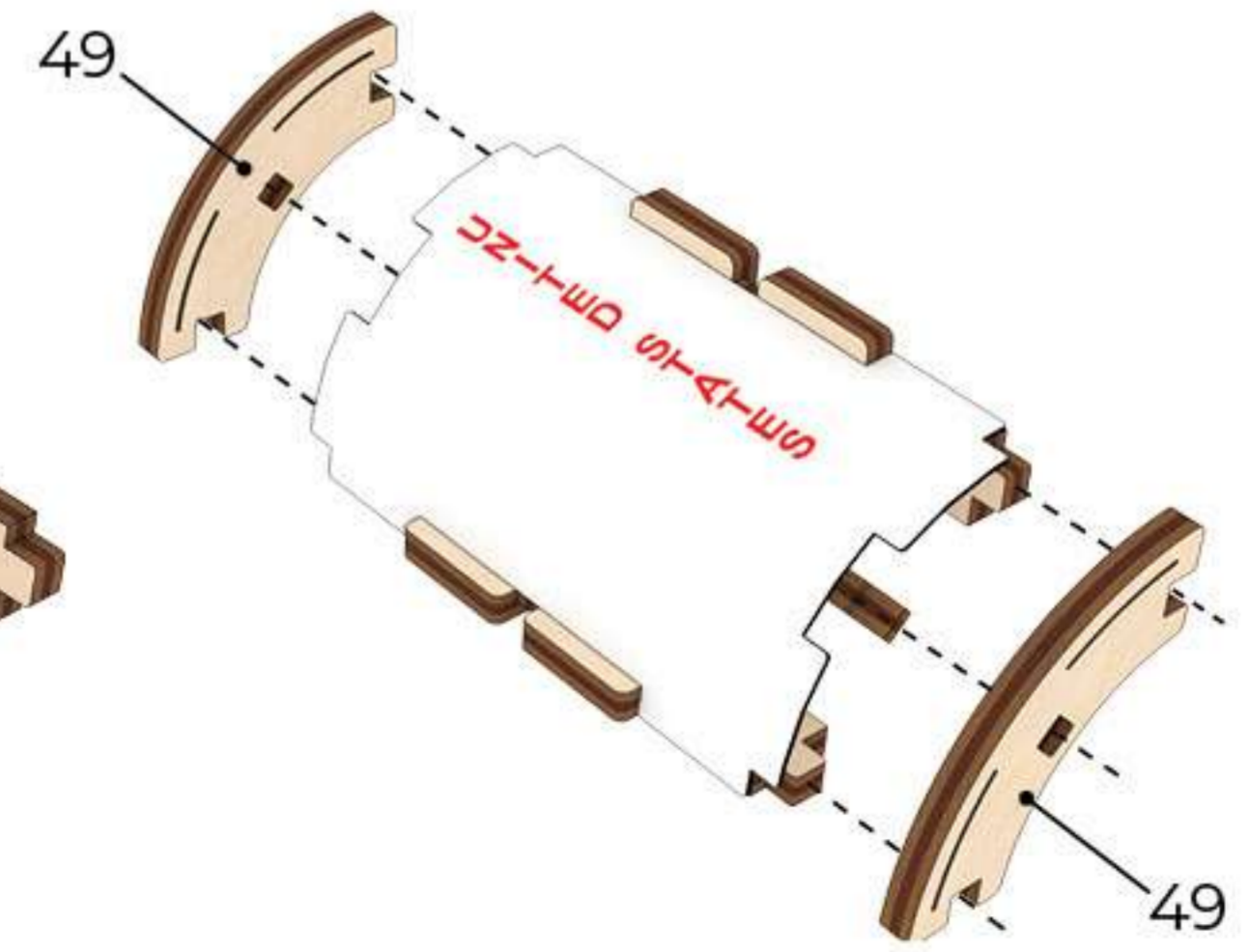

d10

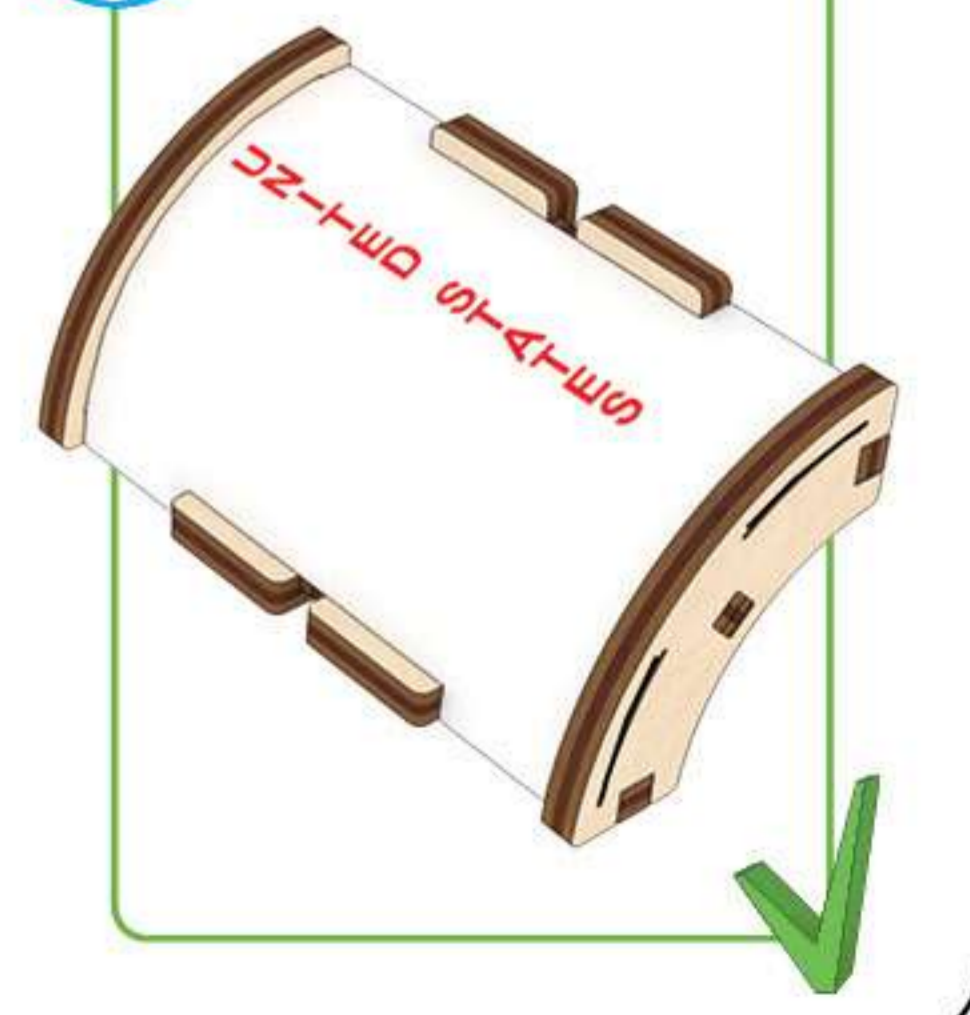

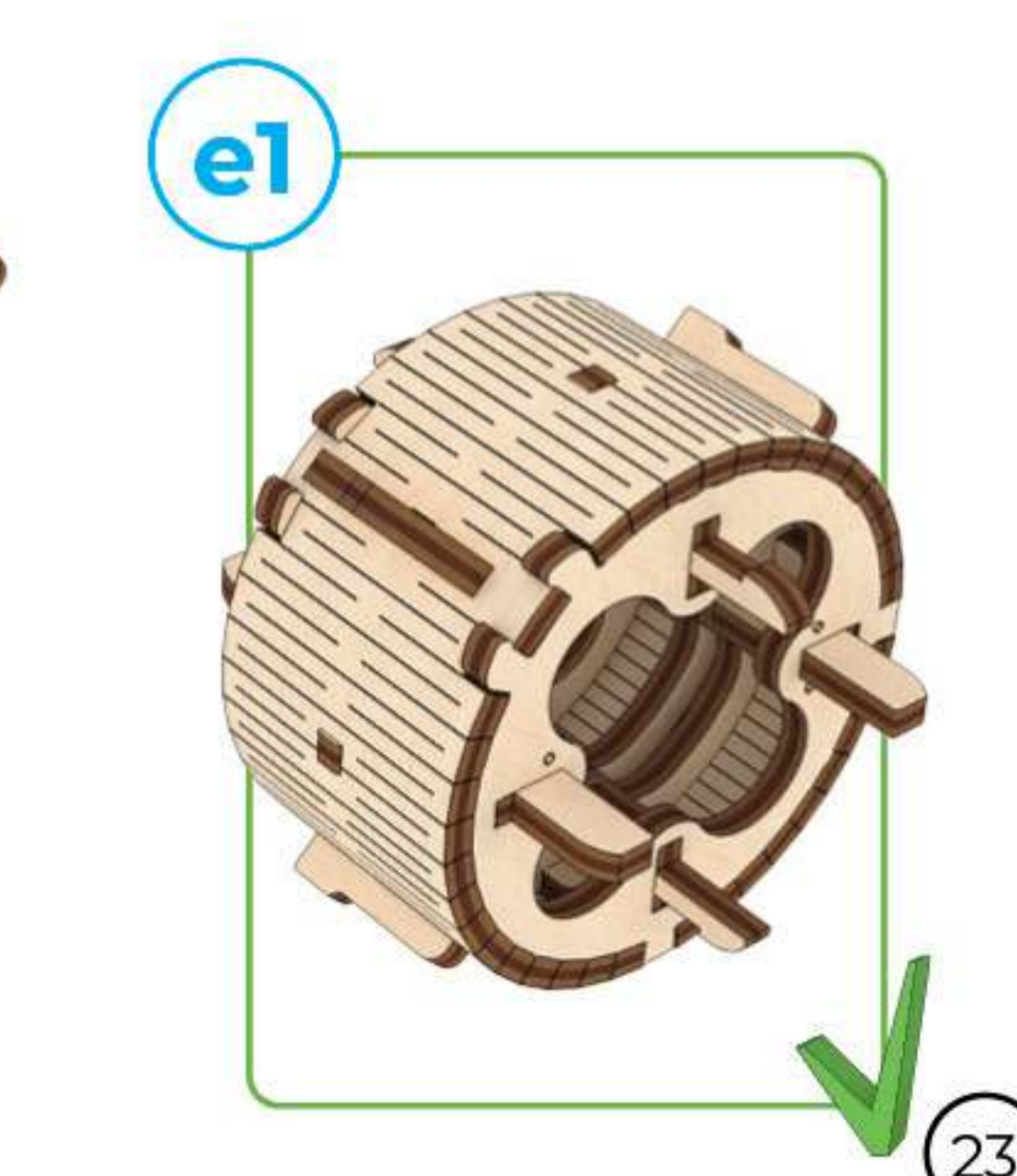
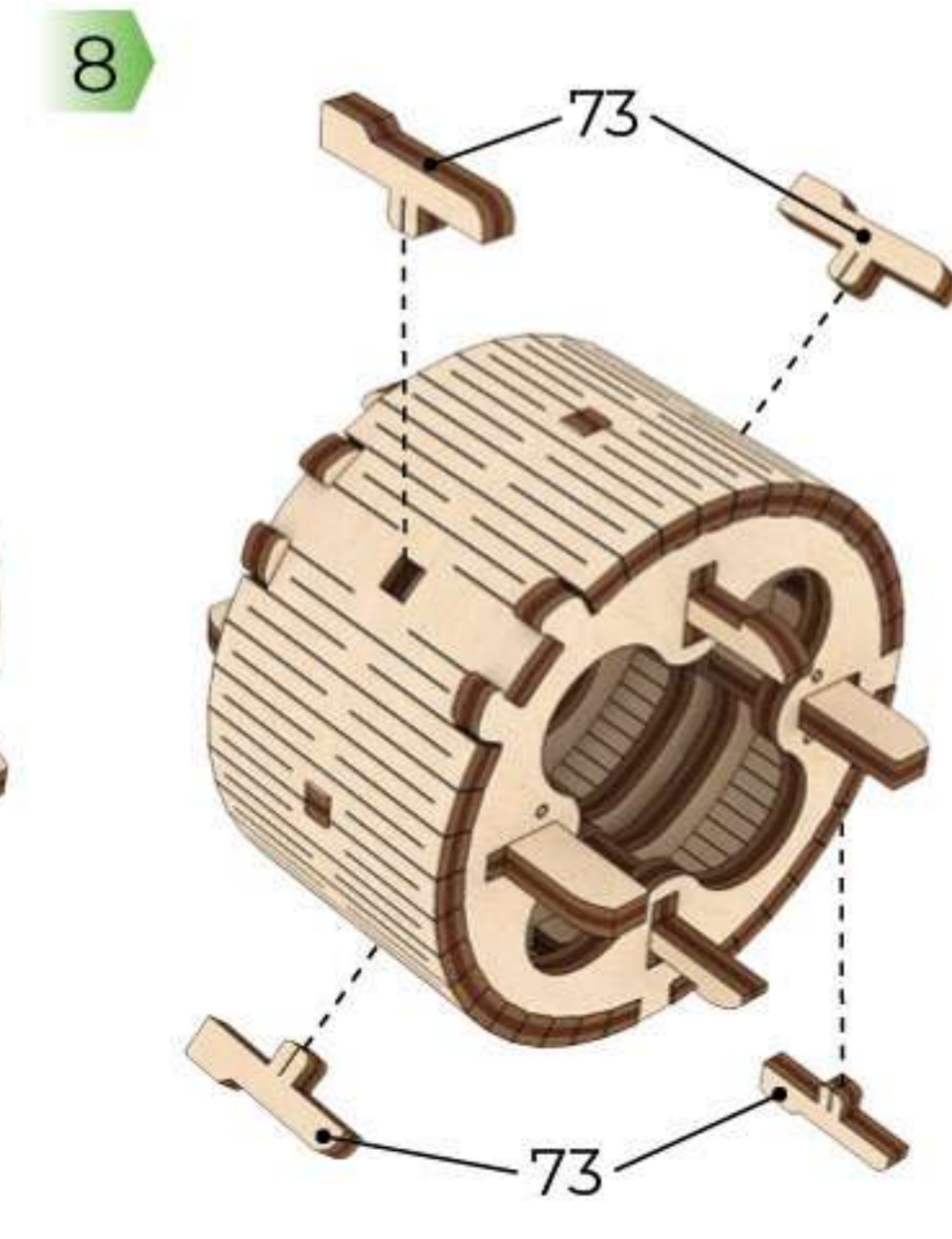
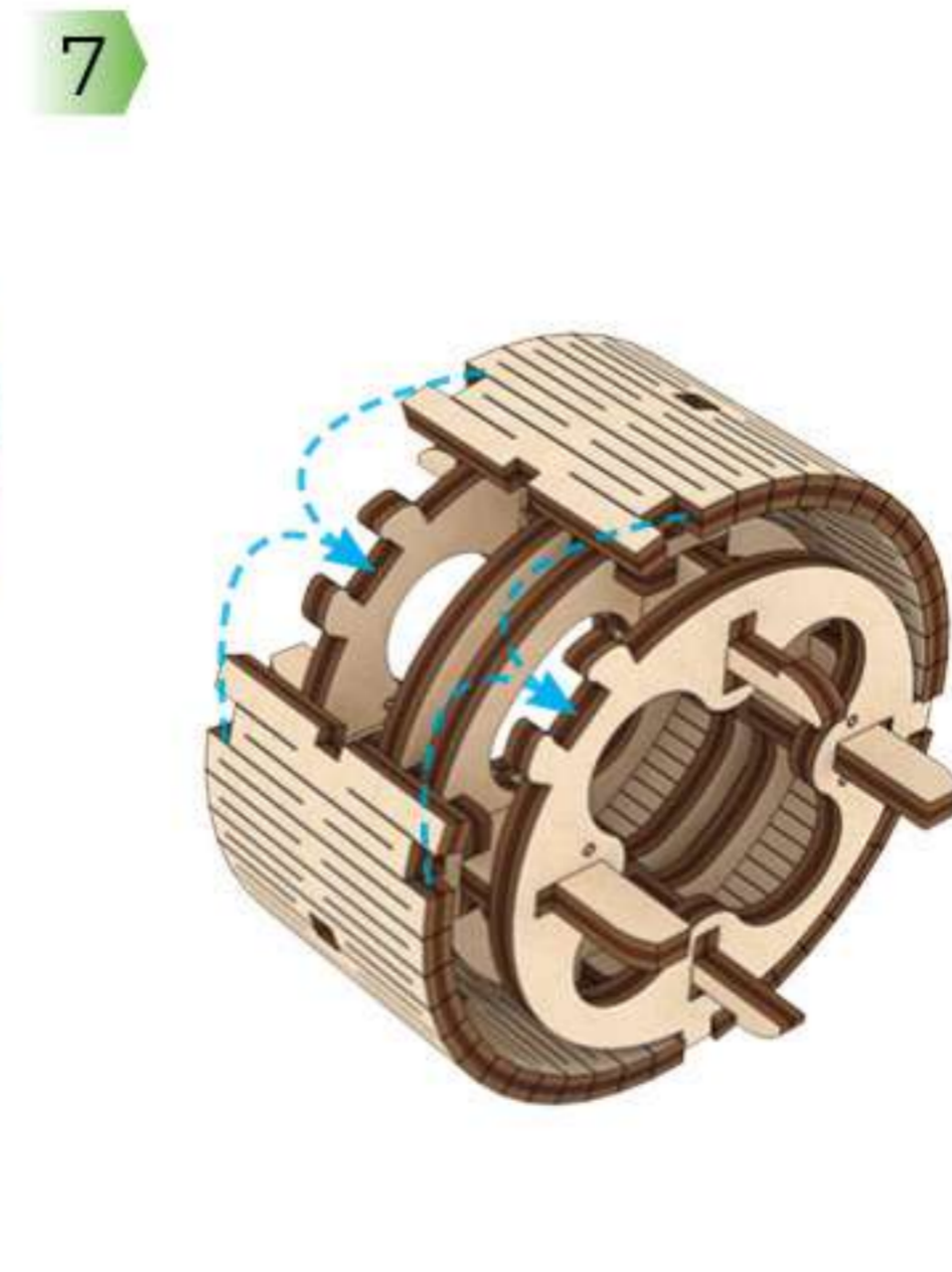
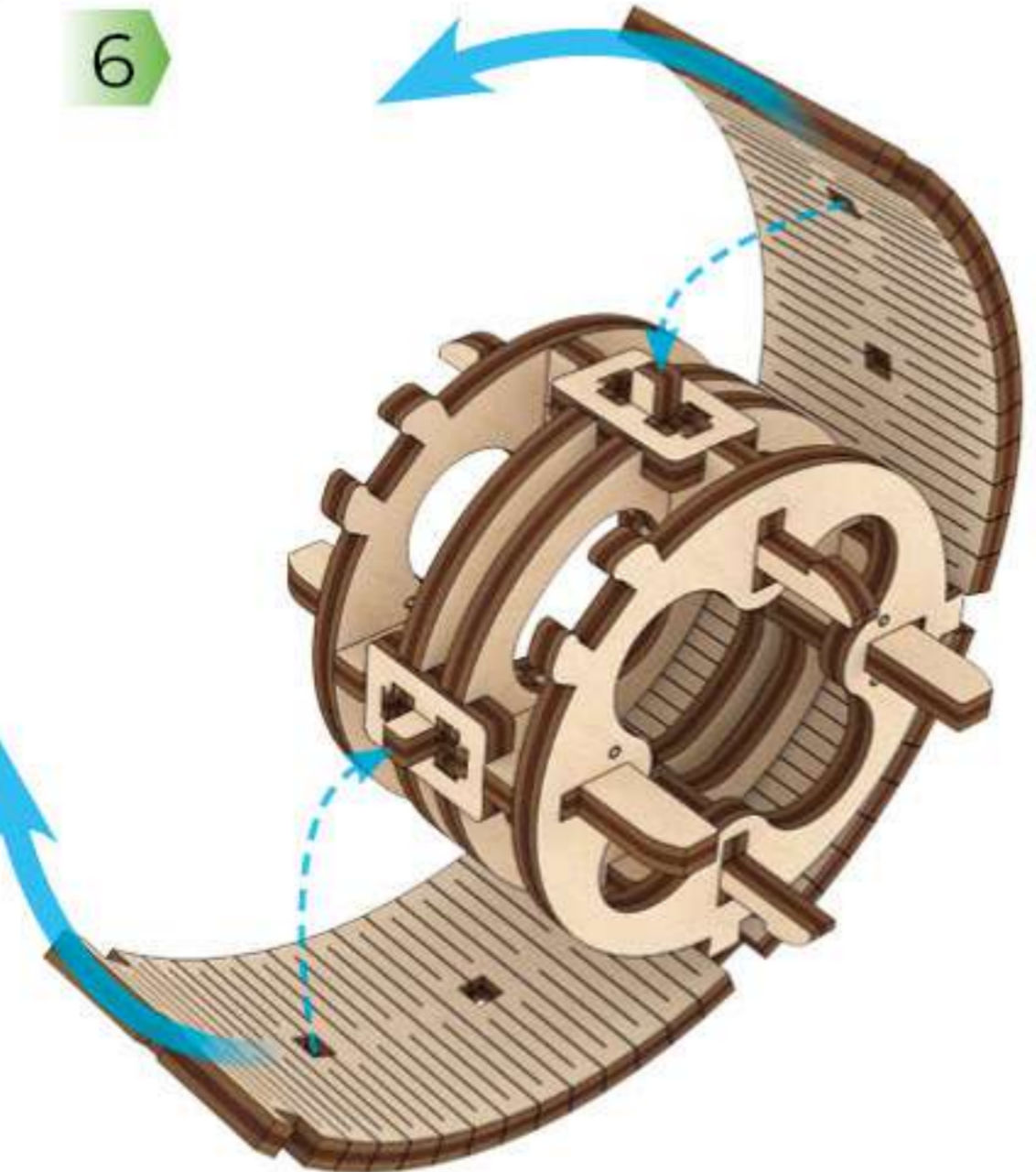
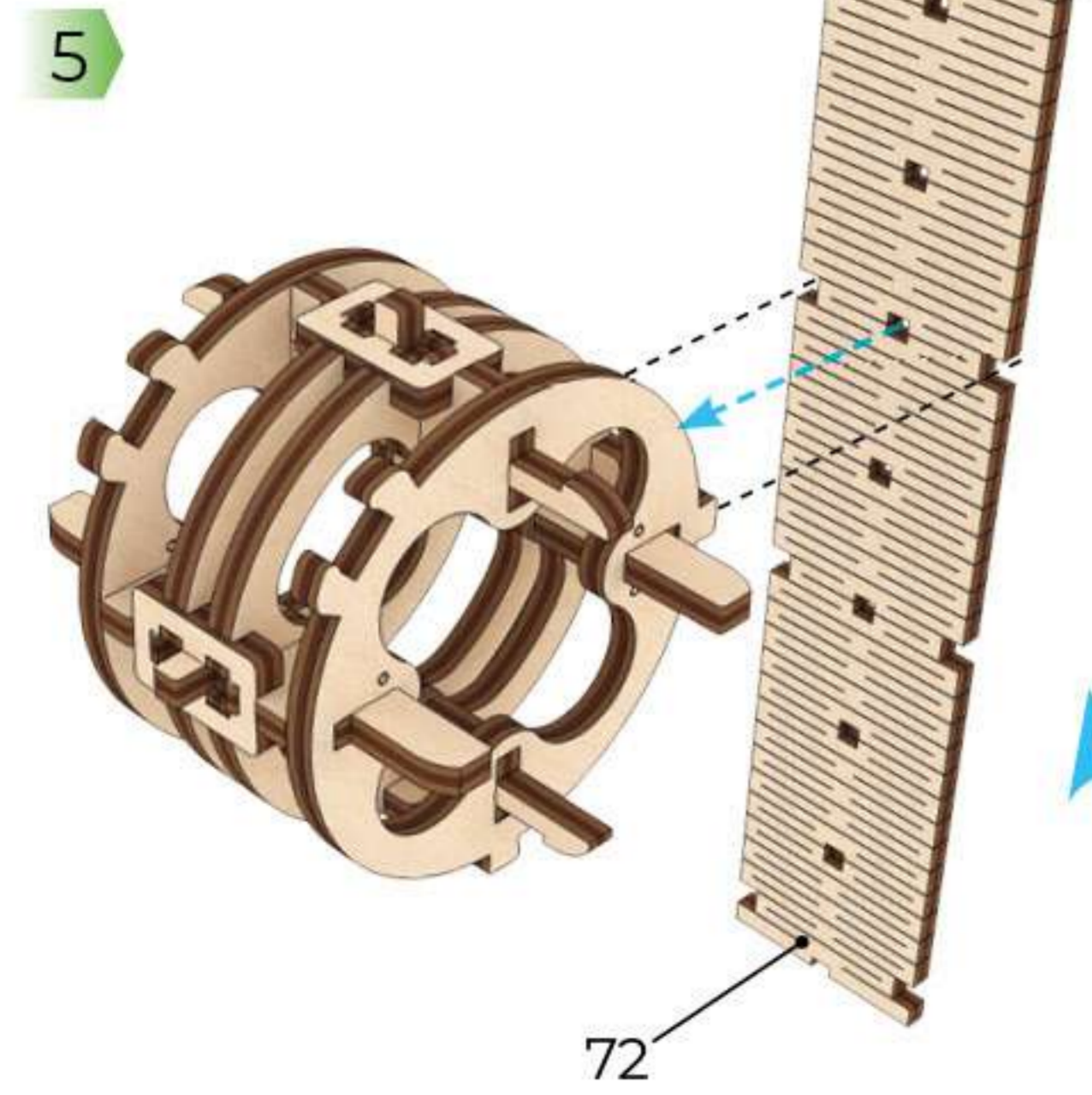
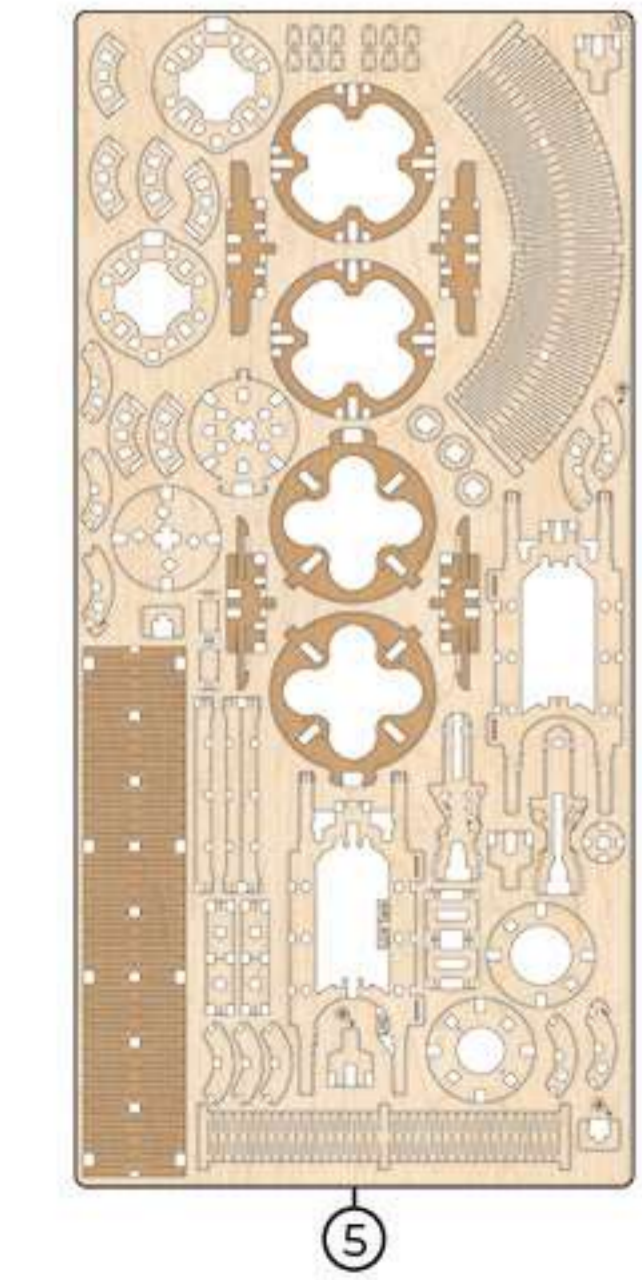
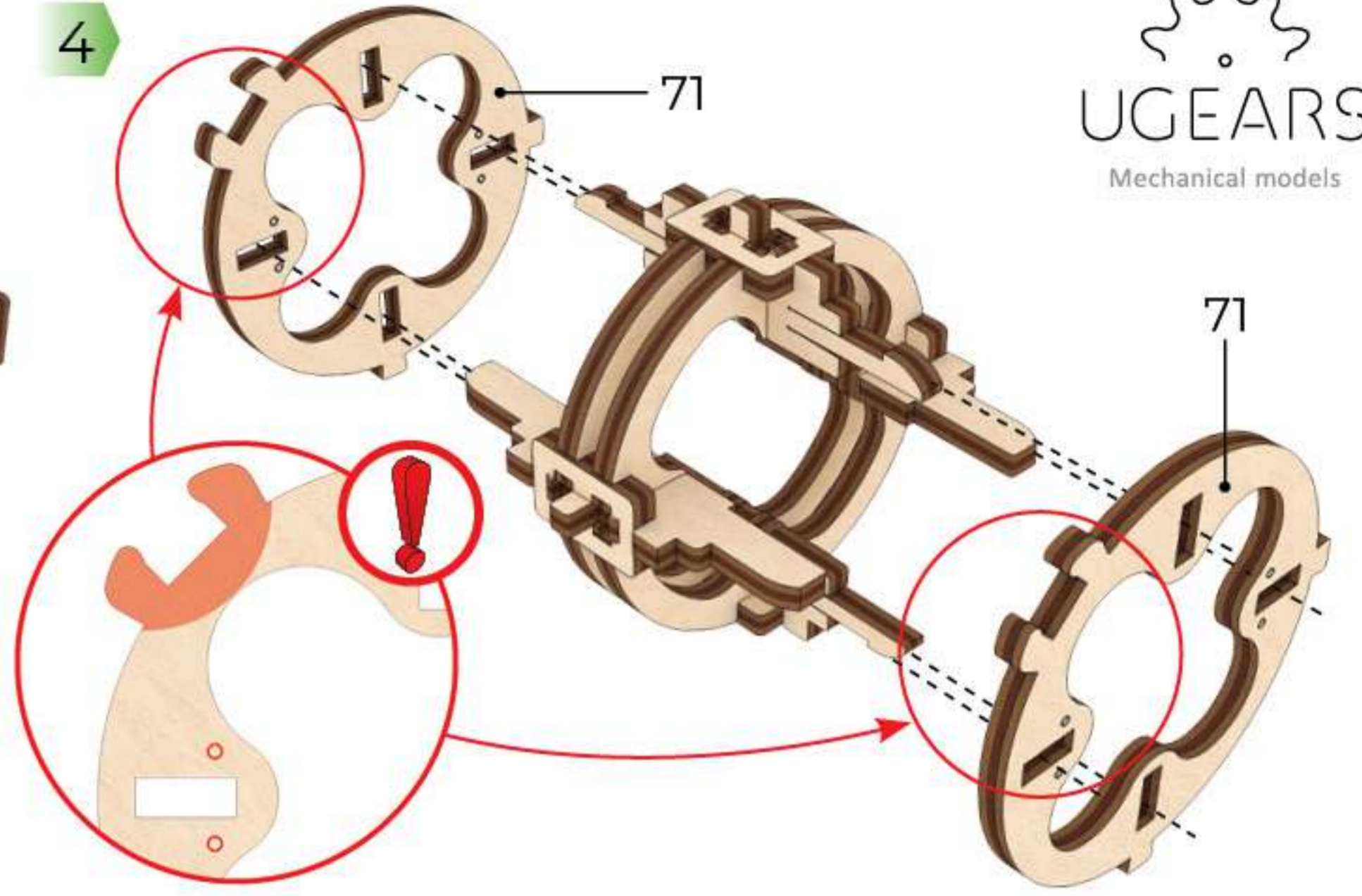
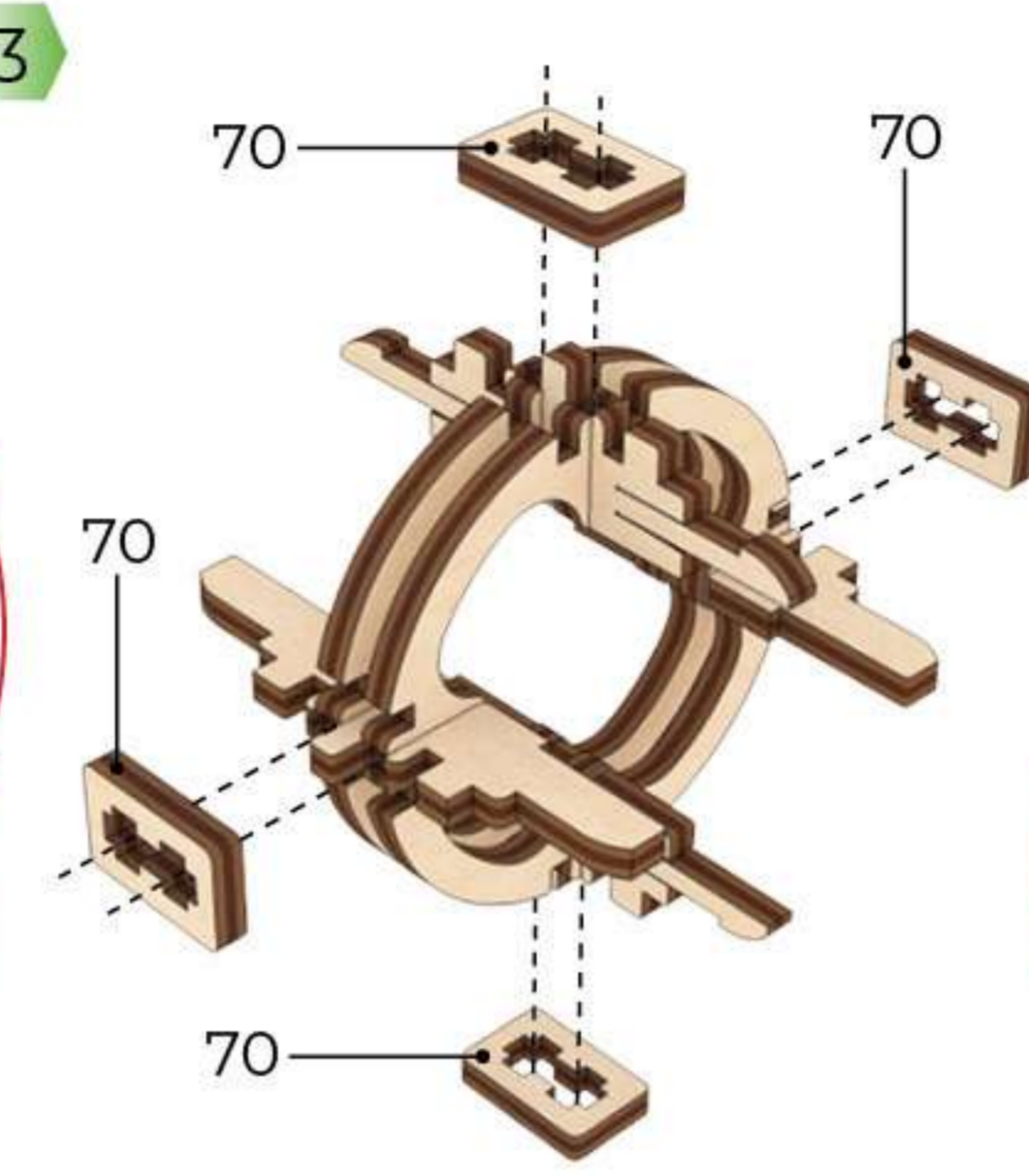
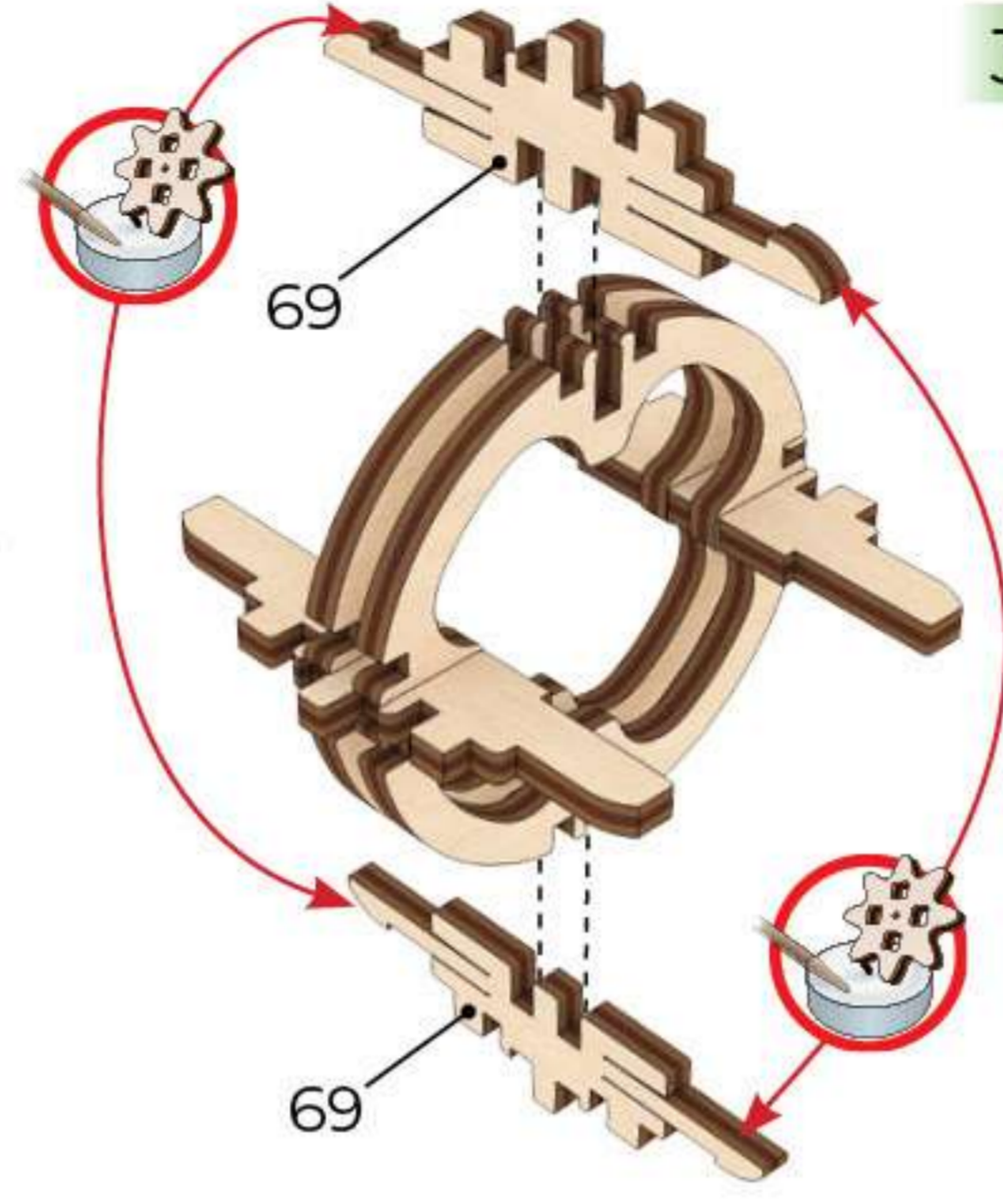
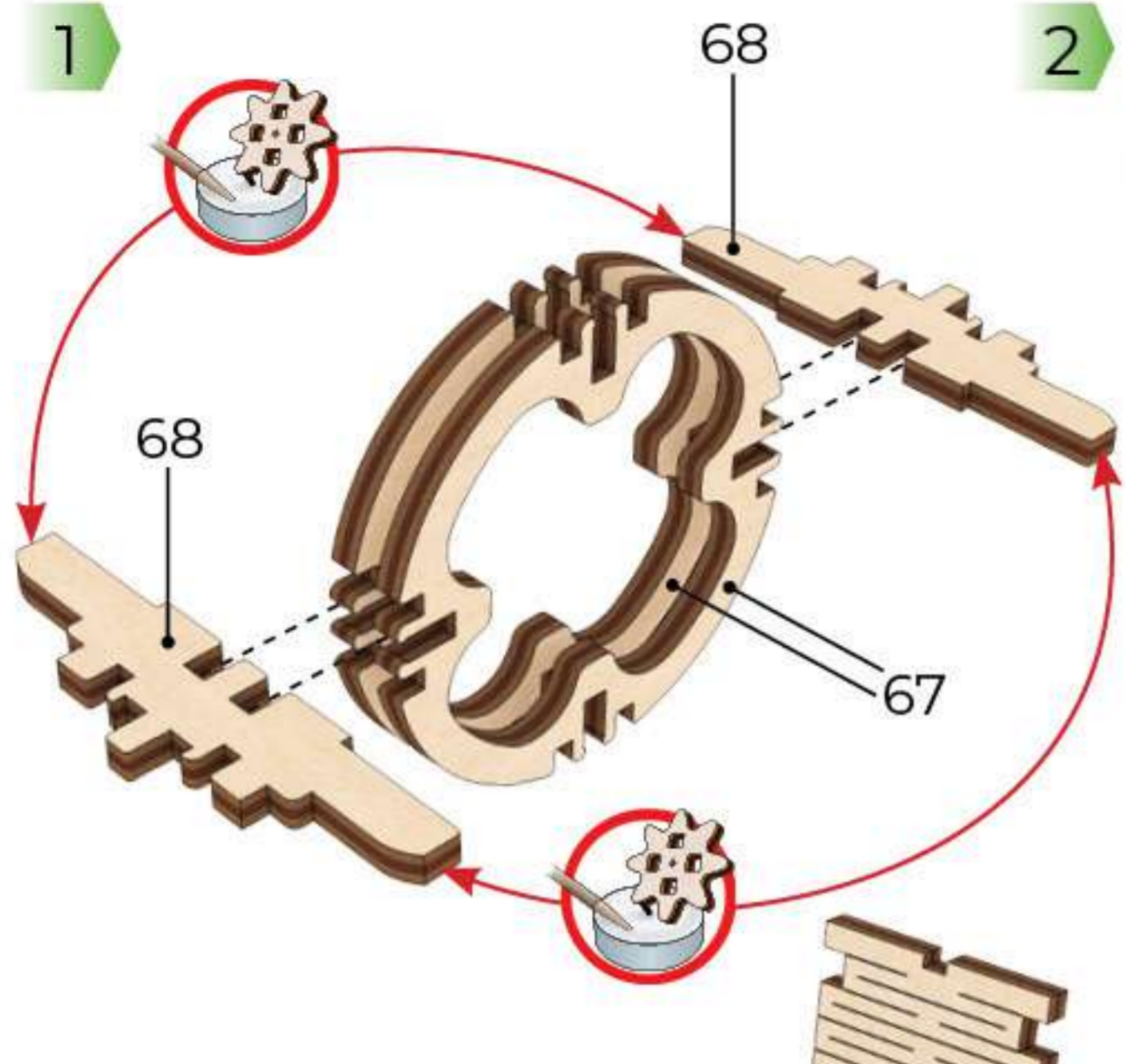
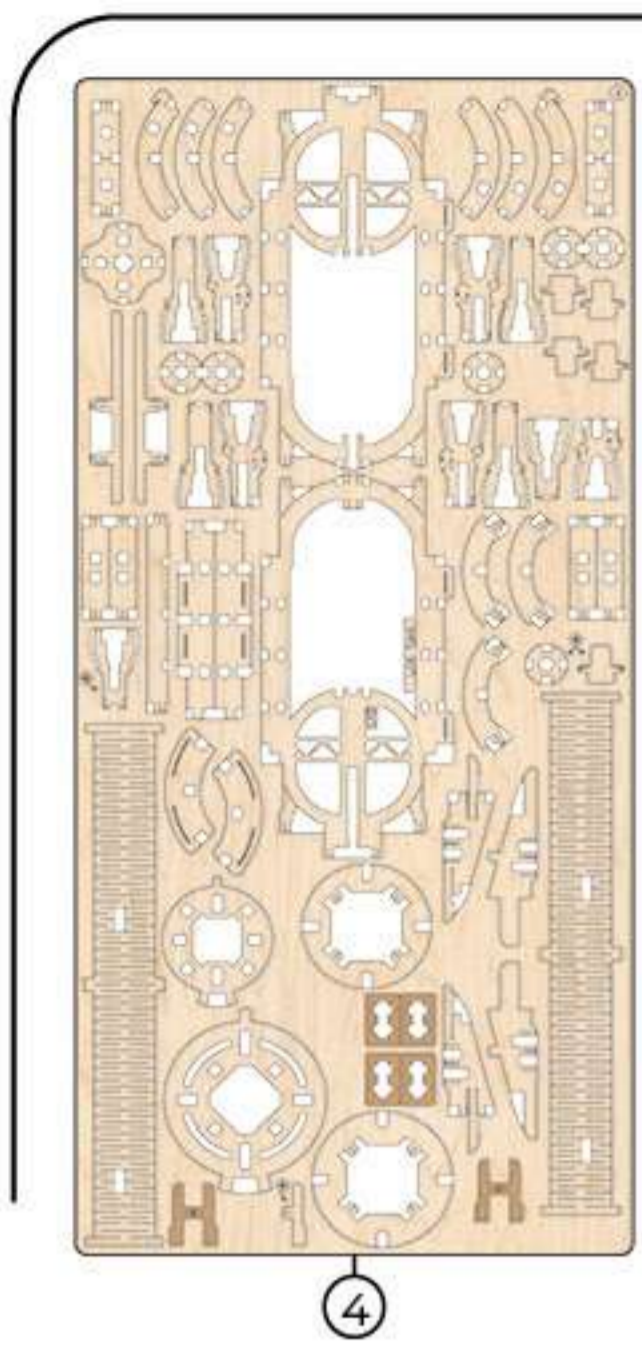

Mechanical models

1

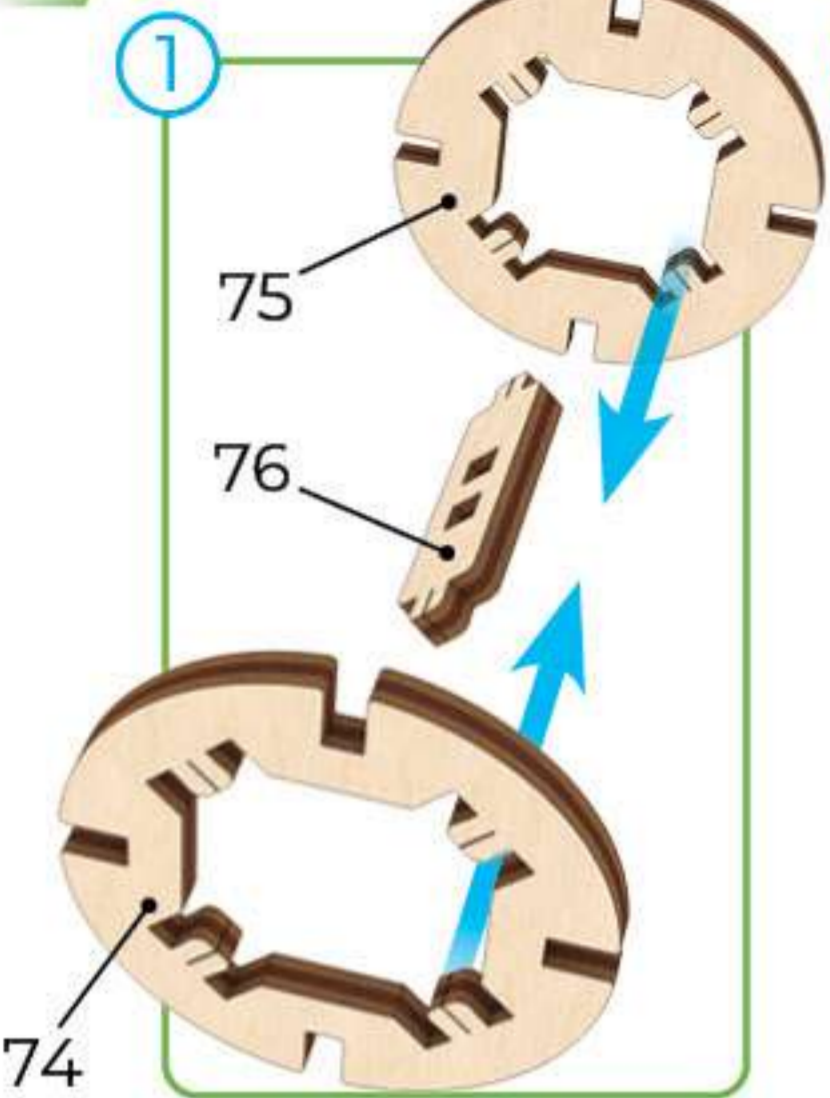

2



3



x4

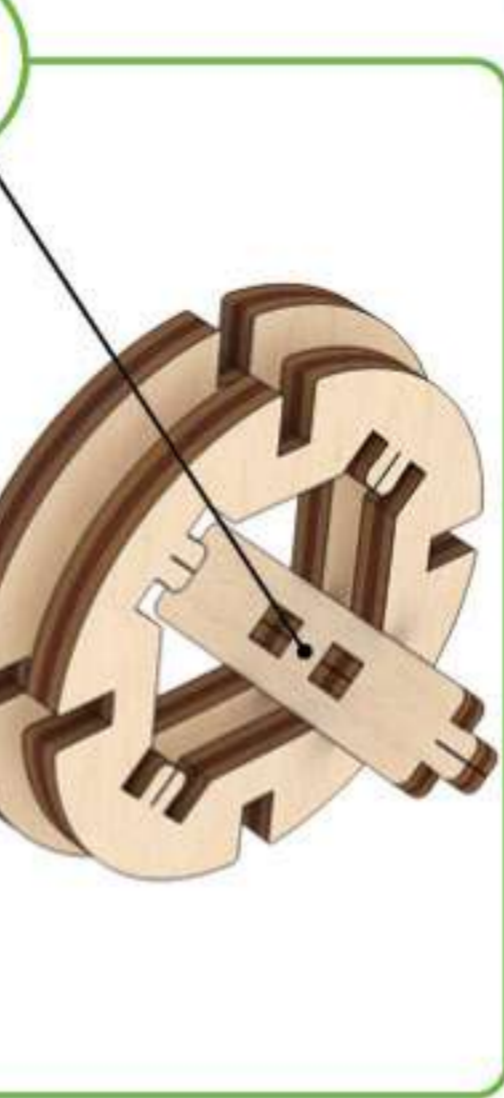

2

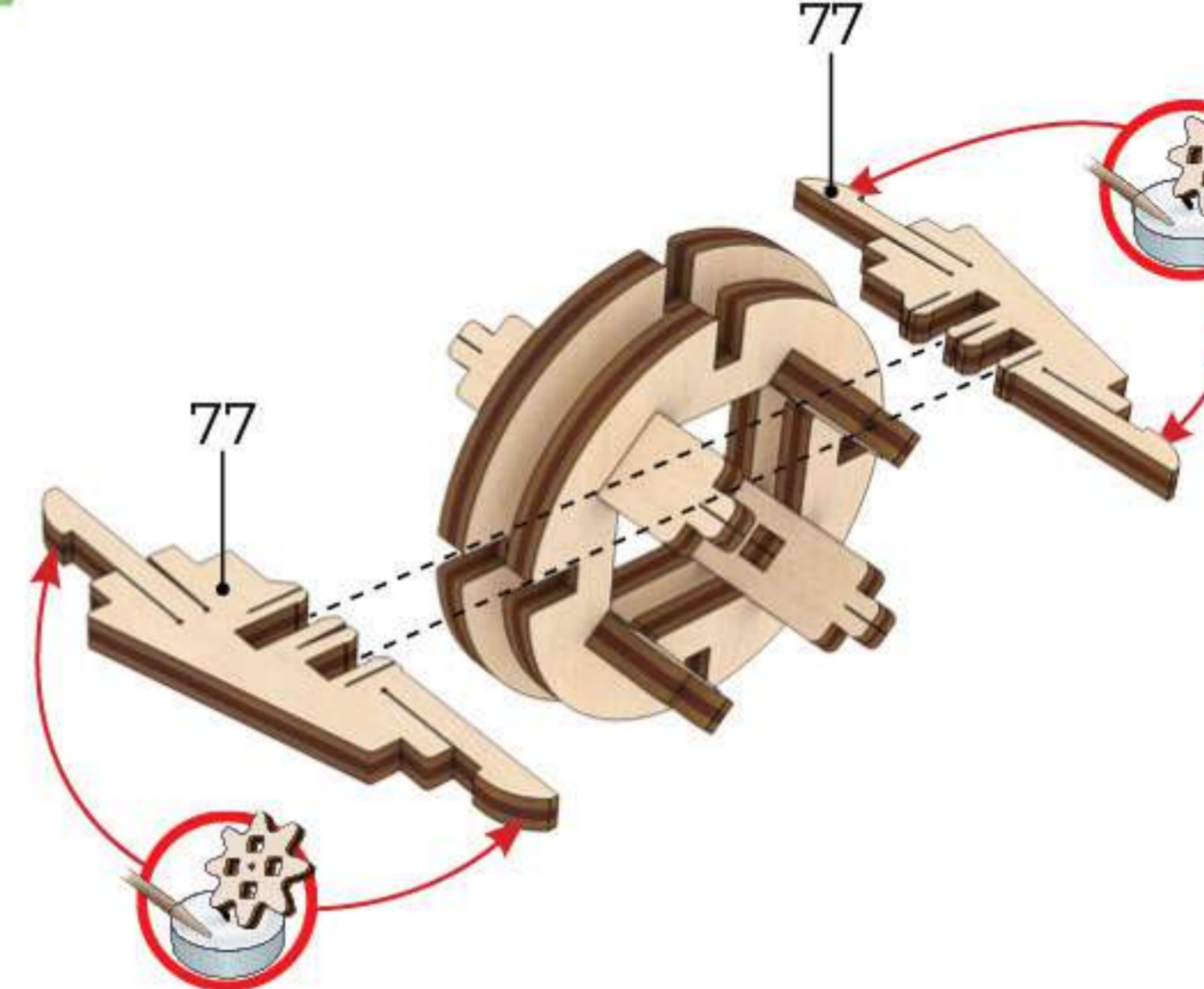

3

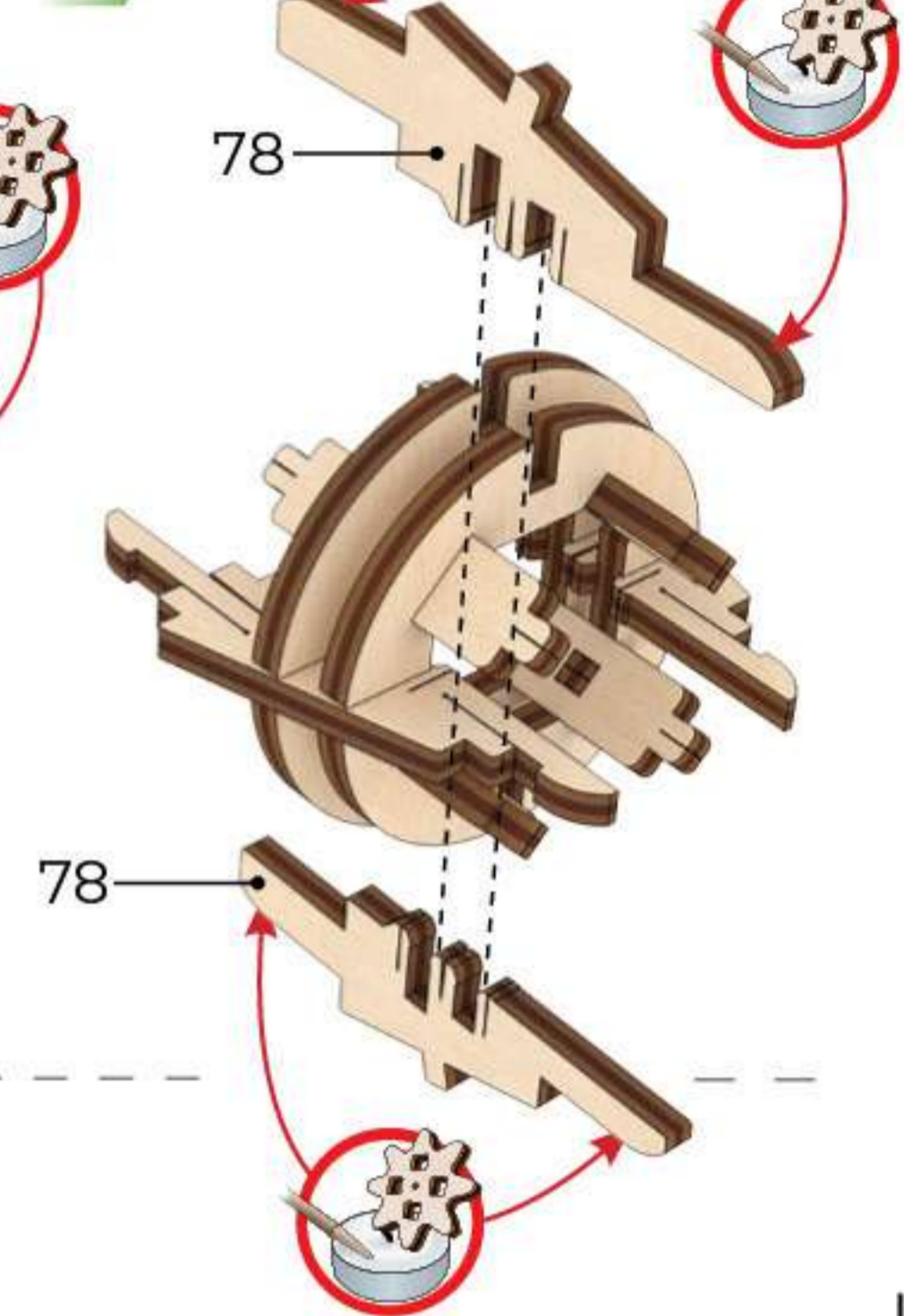

4

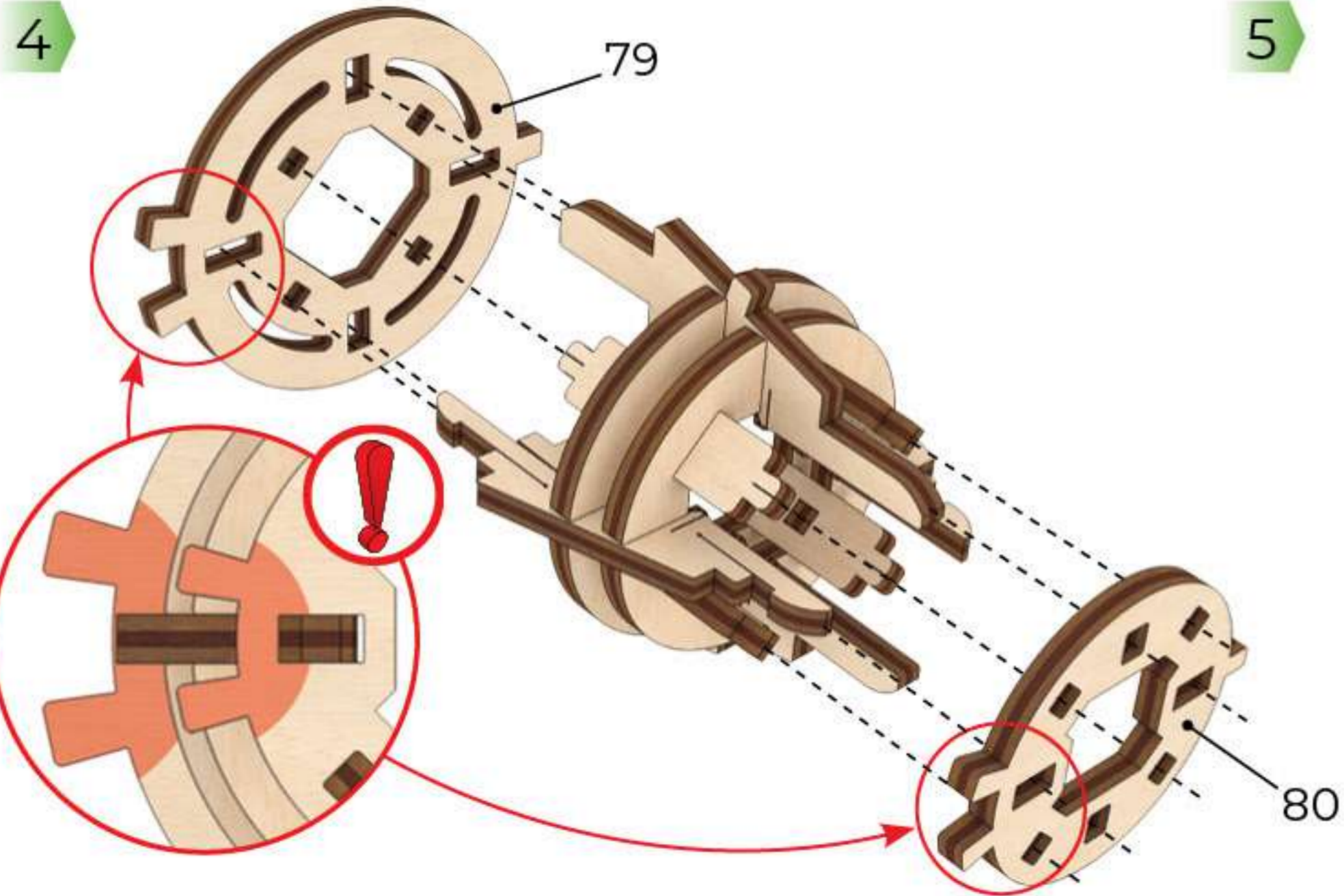

5

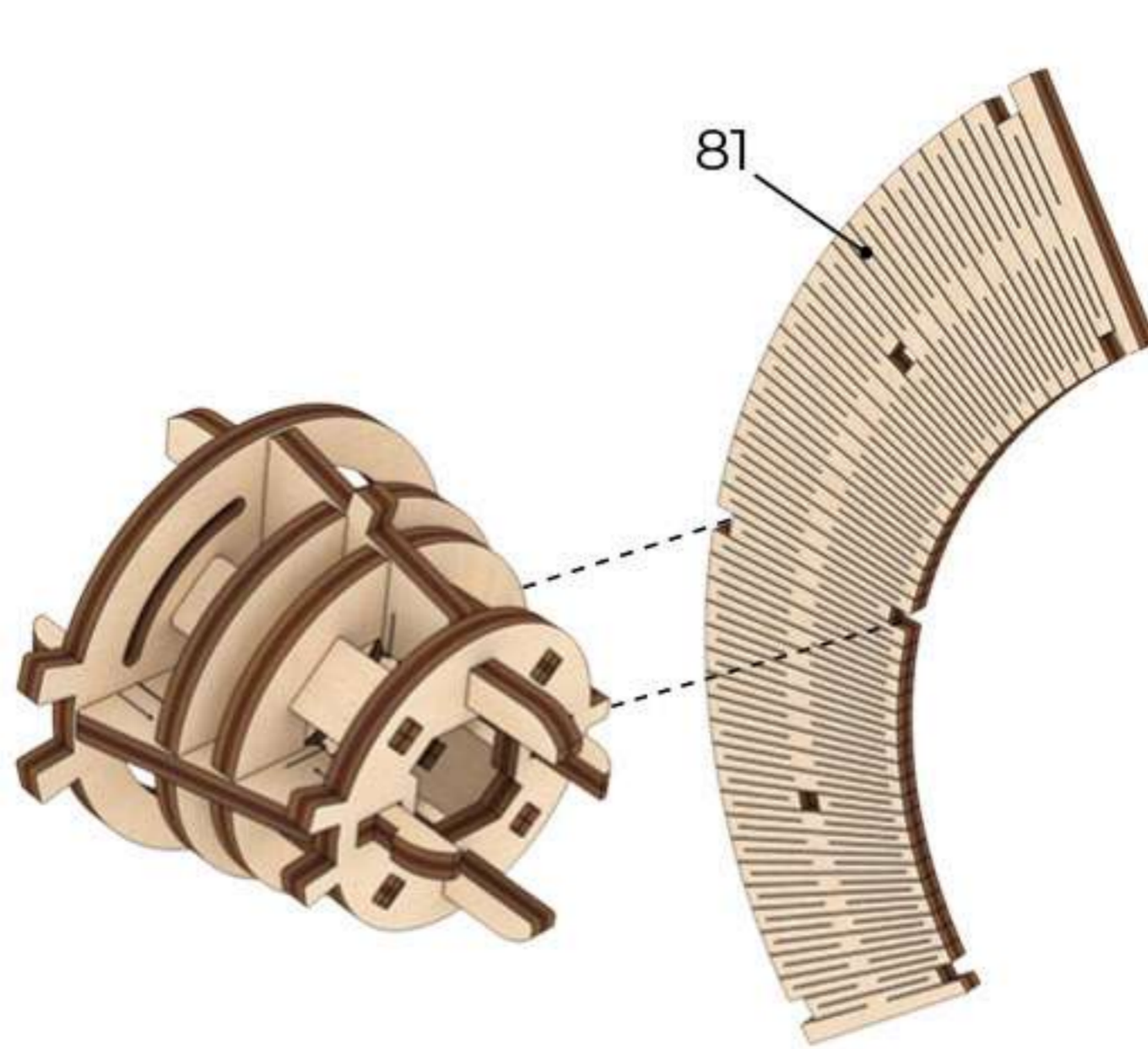

6

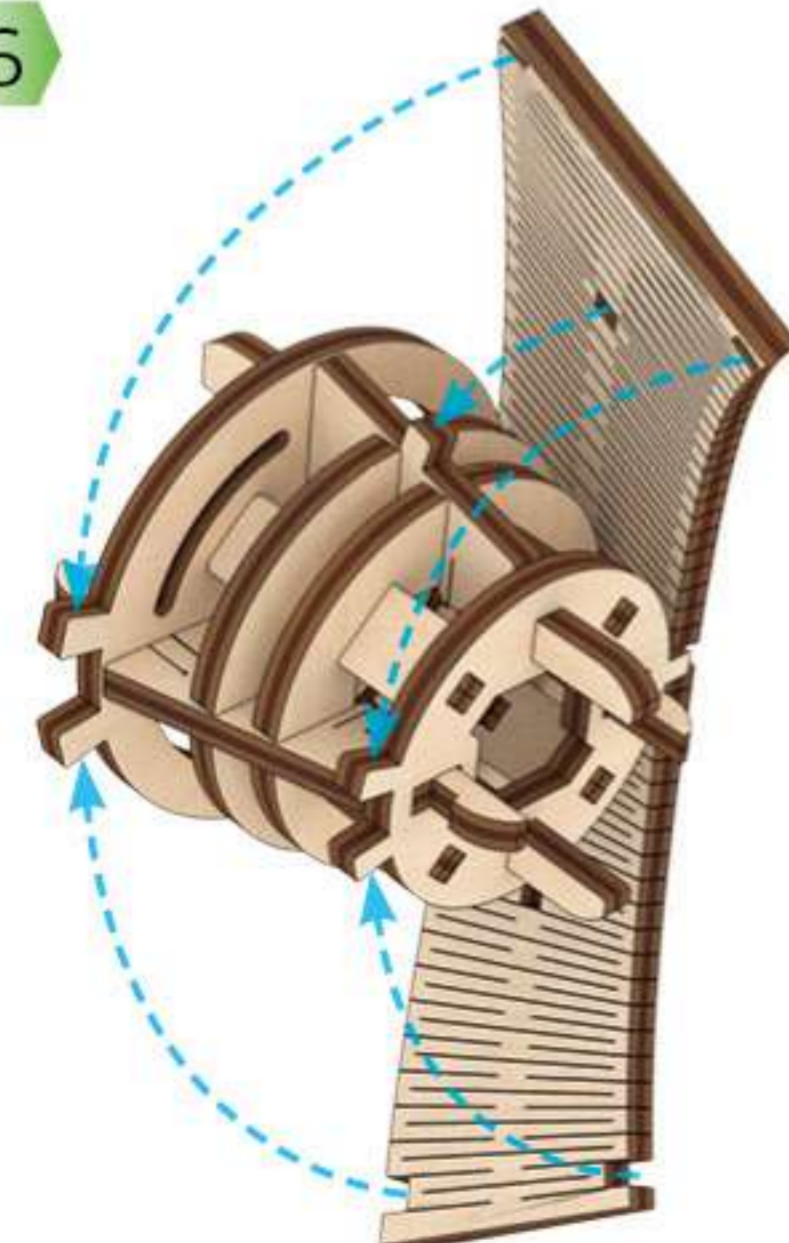

e2

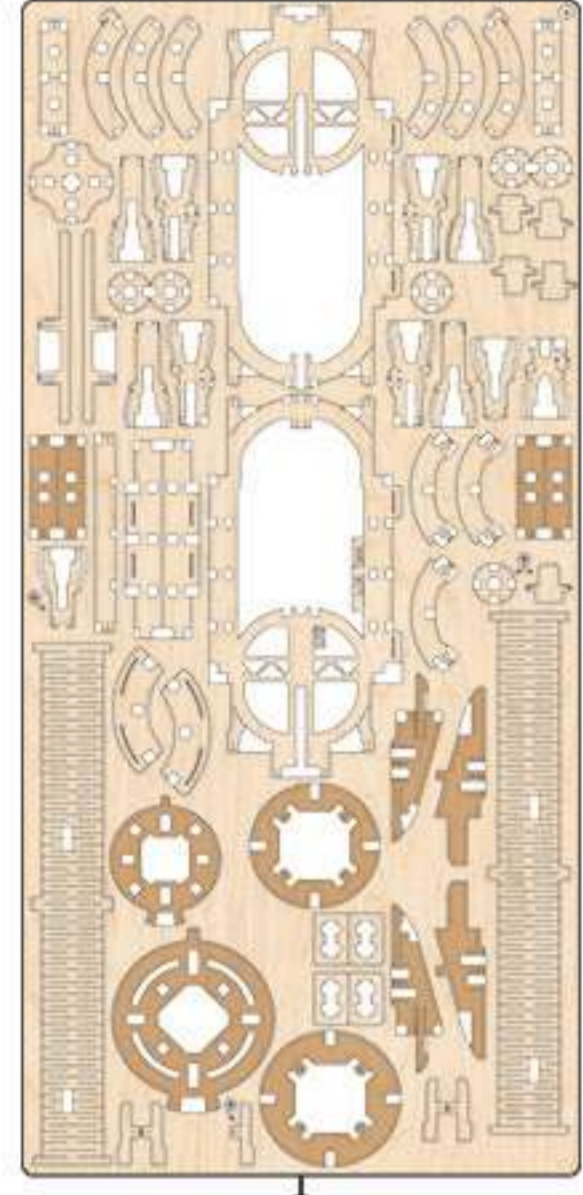

4

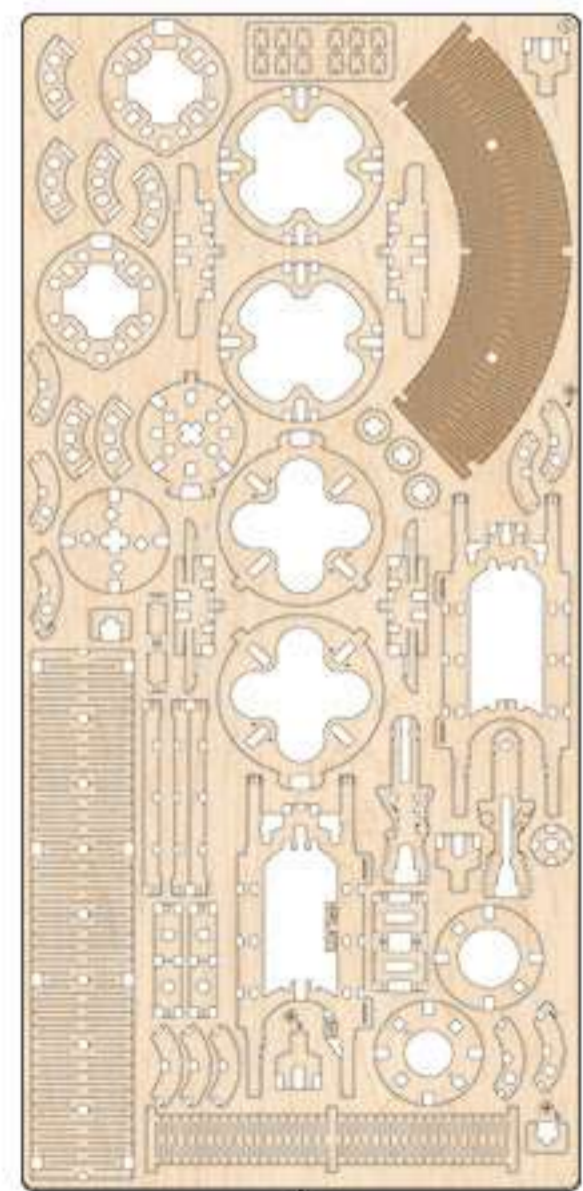

5



1

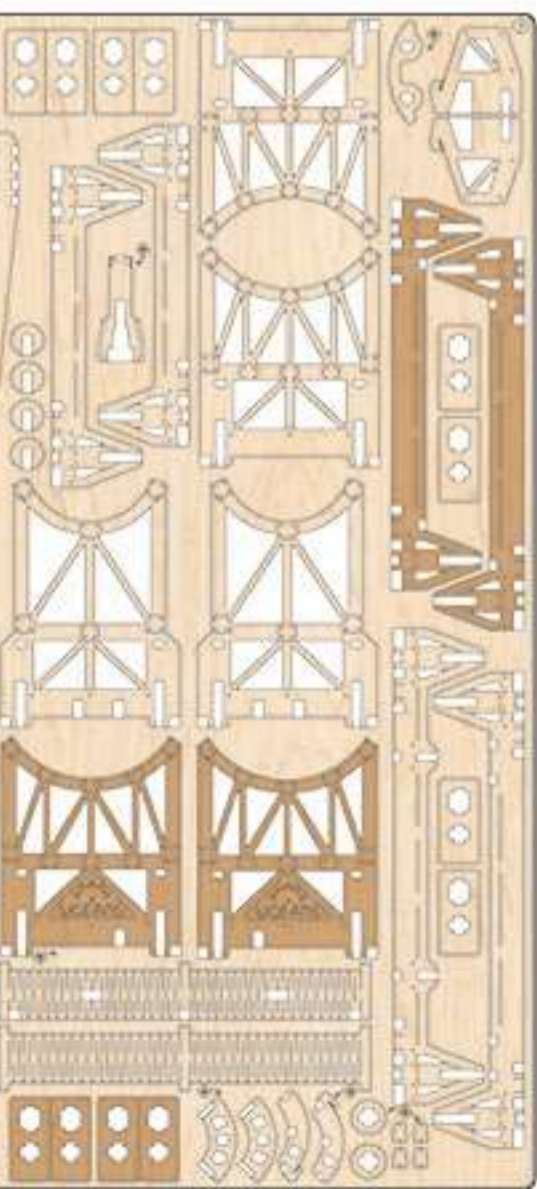
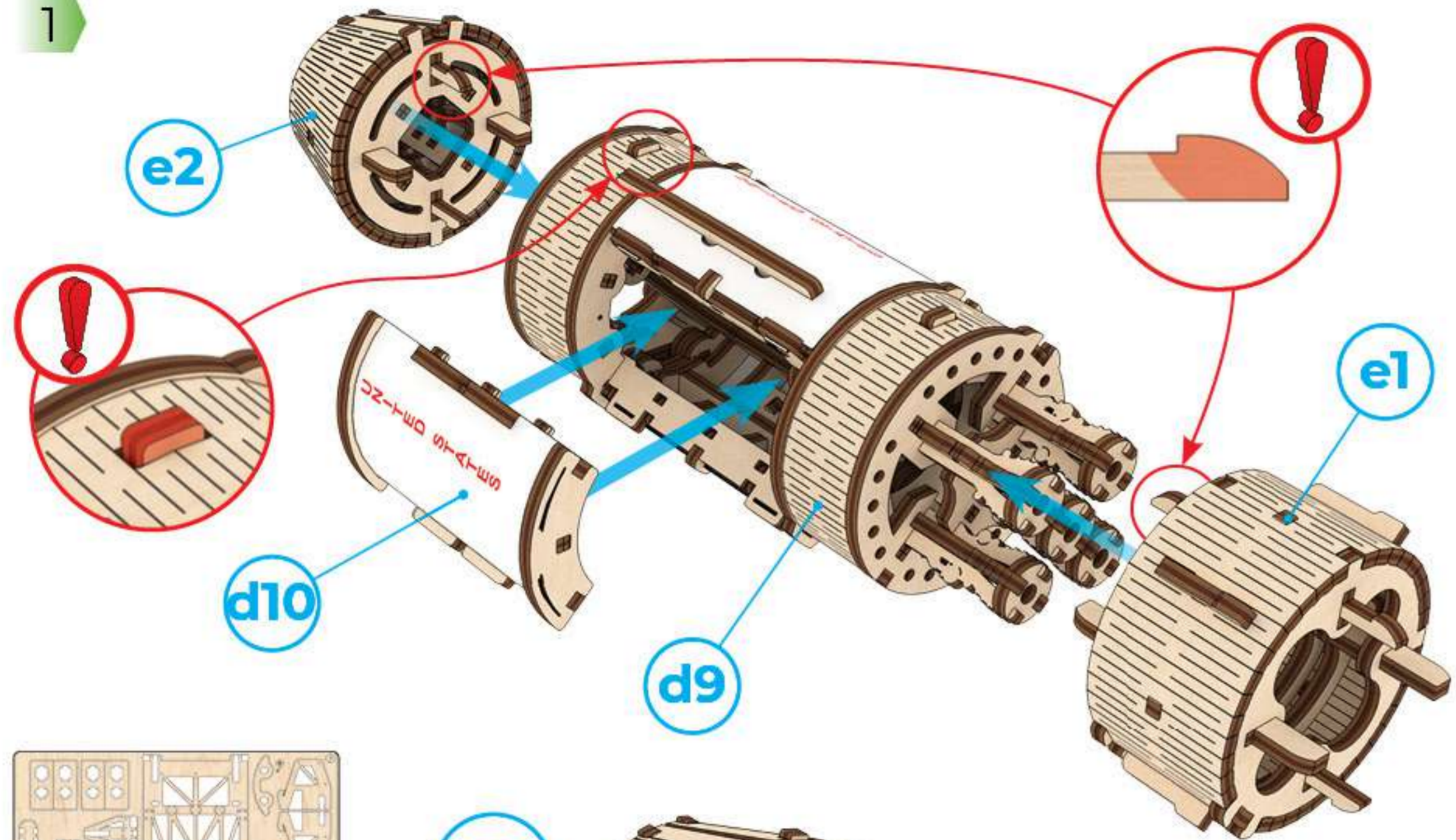

7

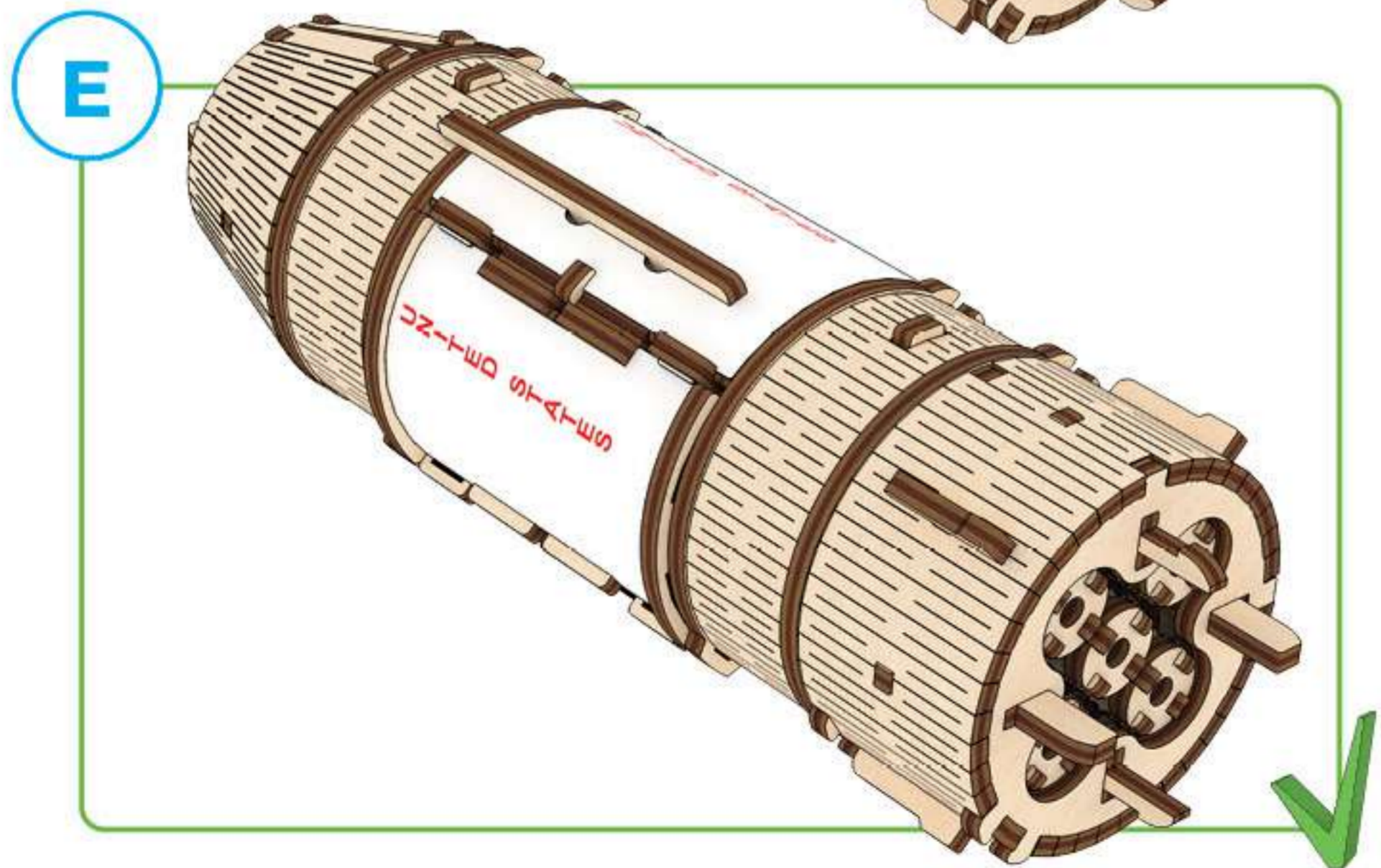

1

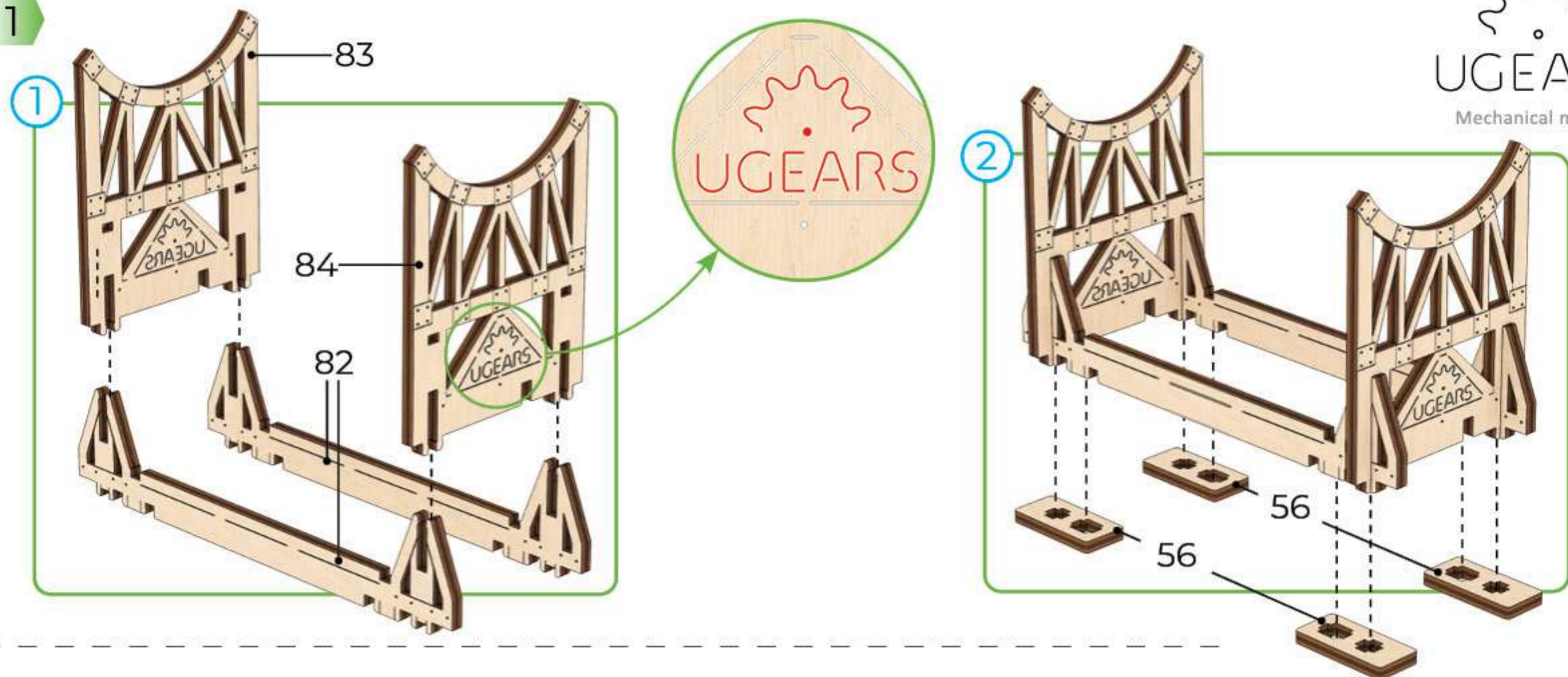

3

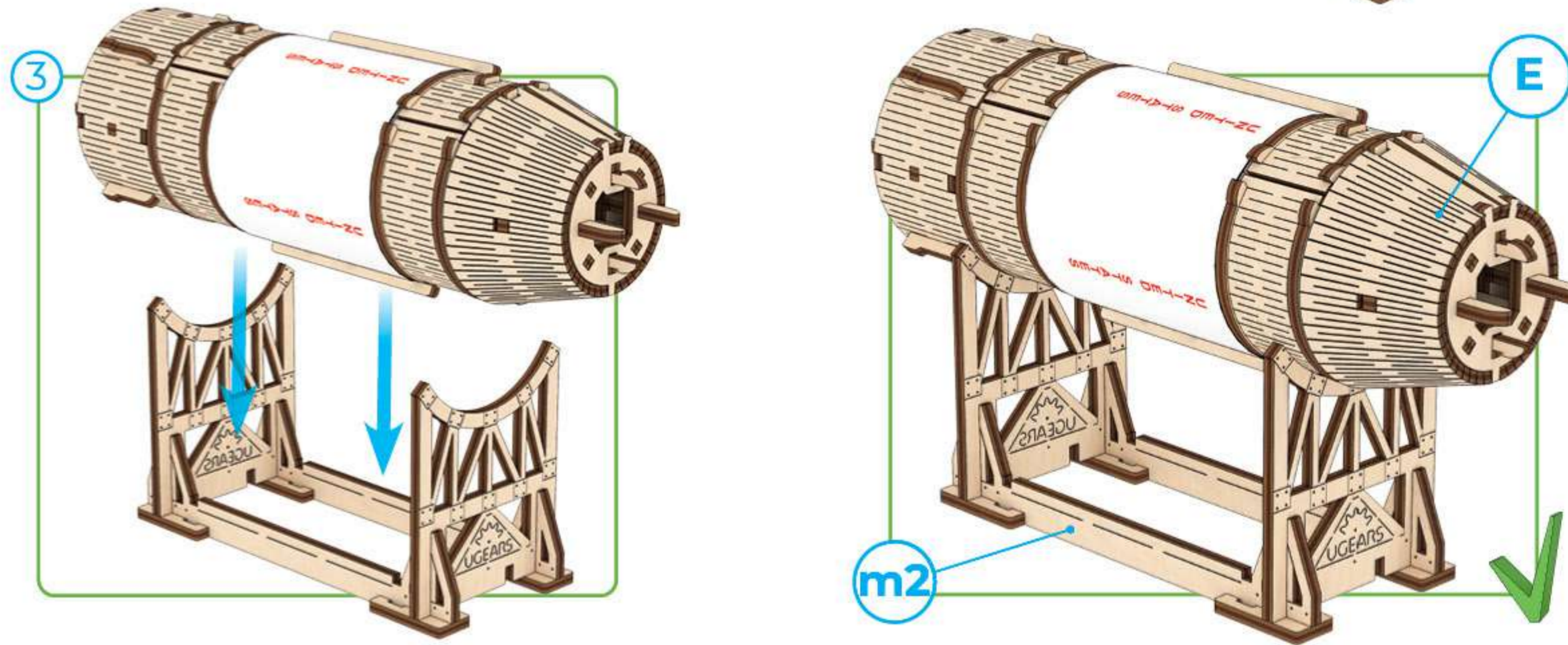

Mechanical models

1

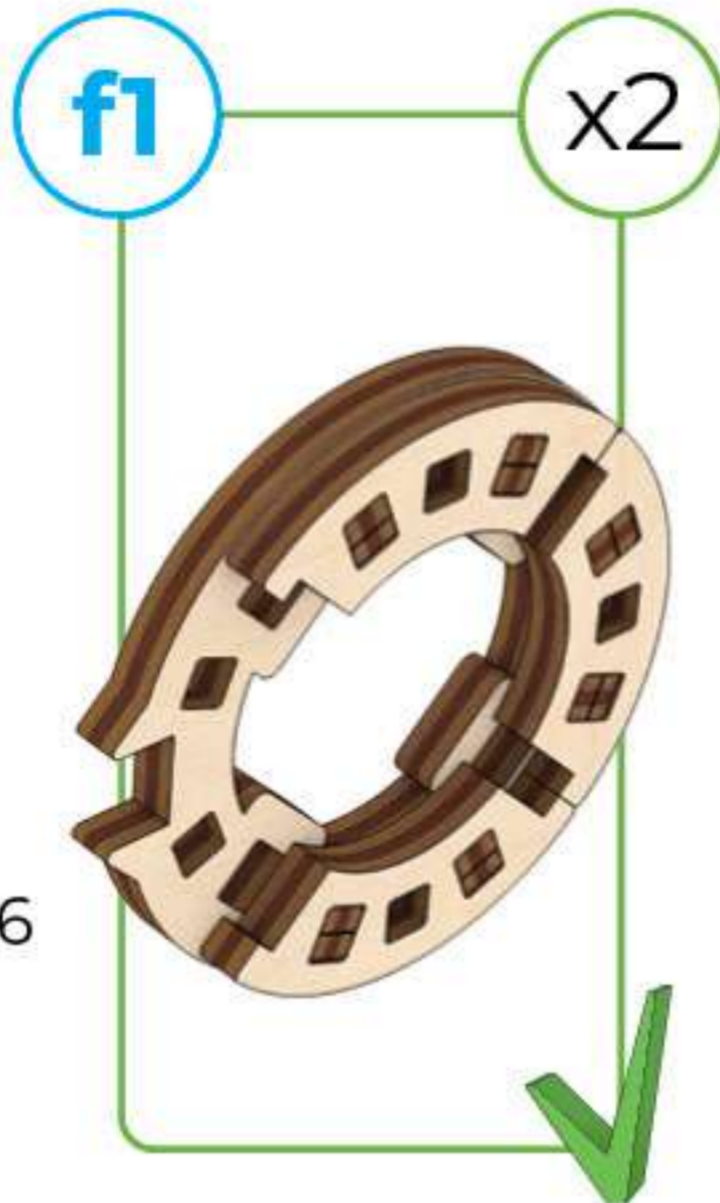
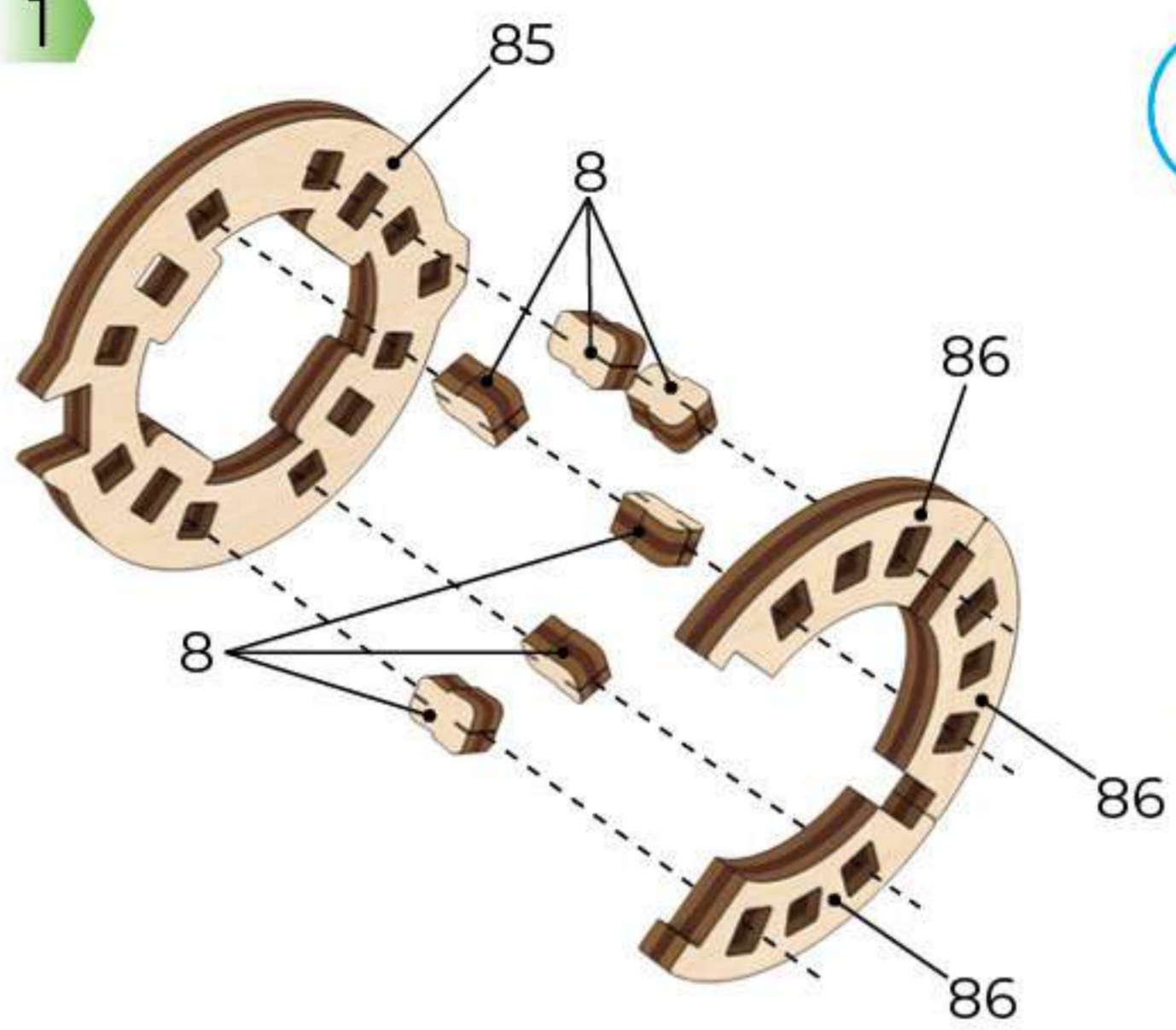

1

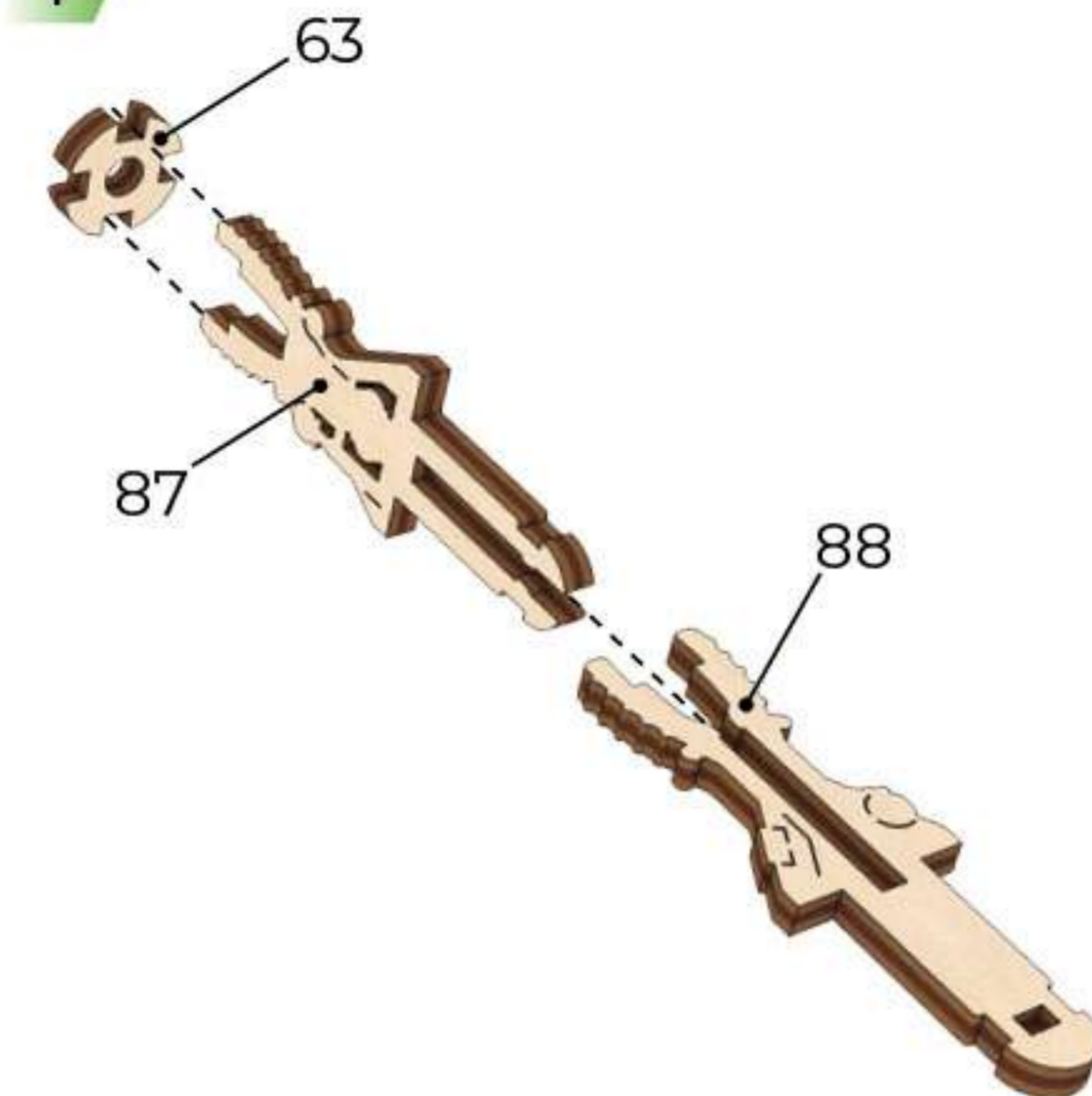

1

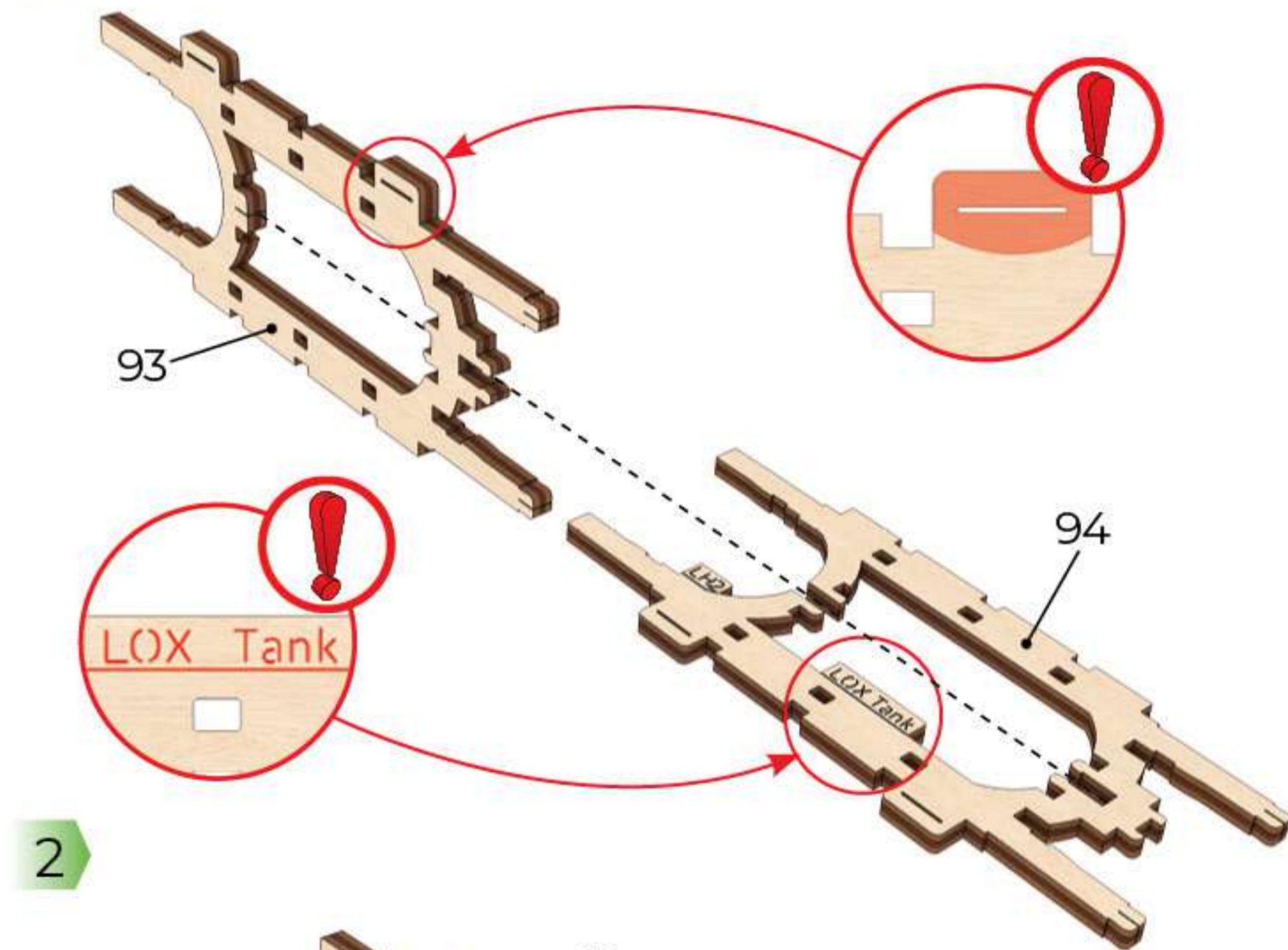

2

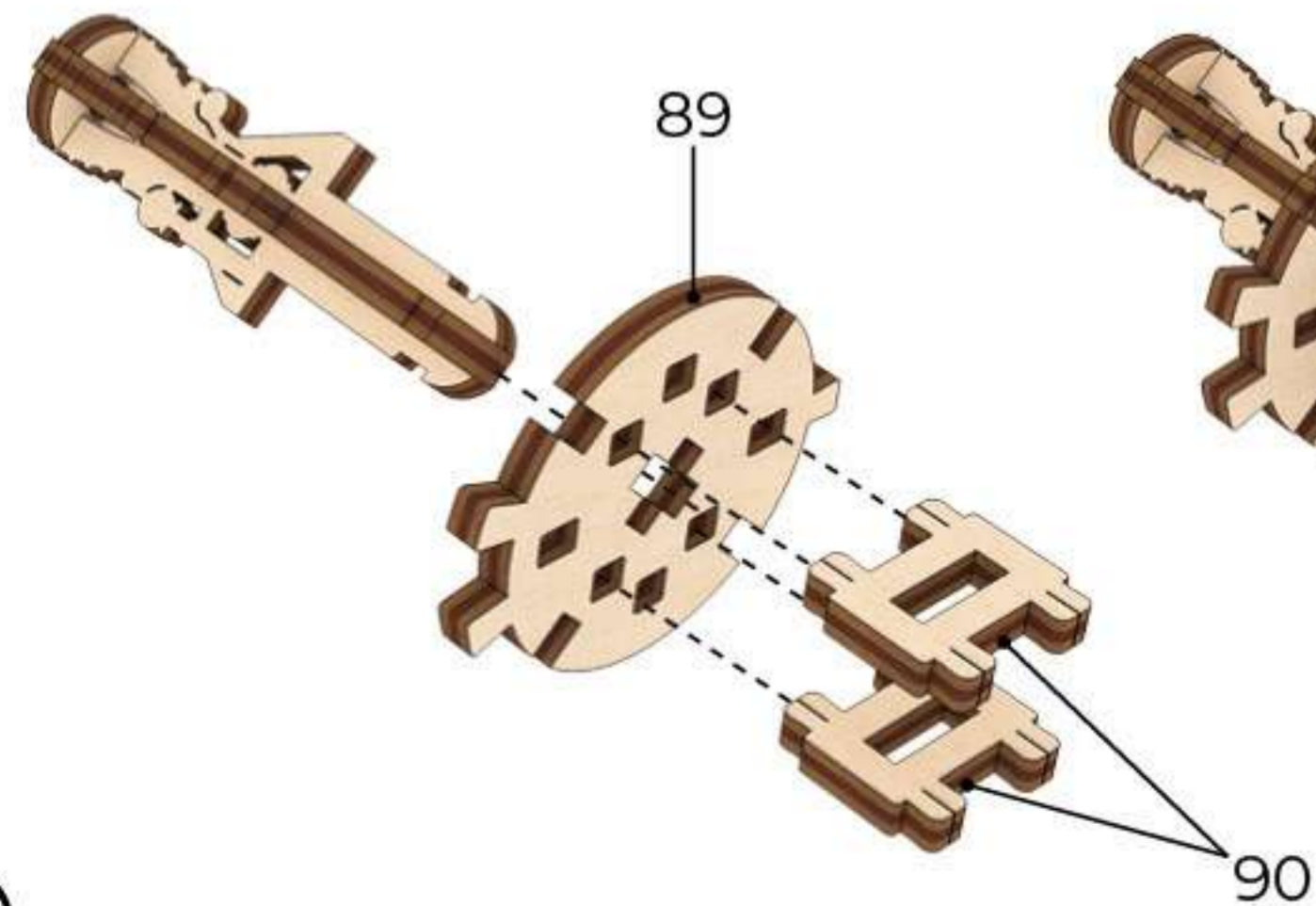

3

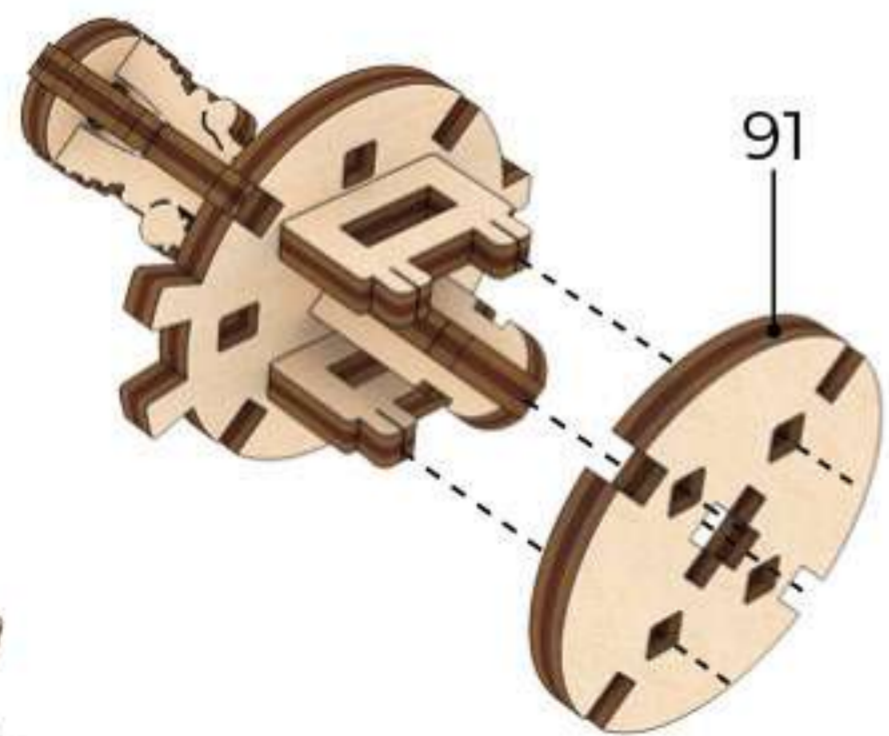

4

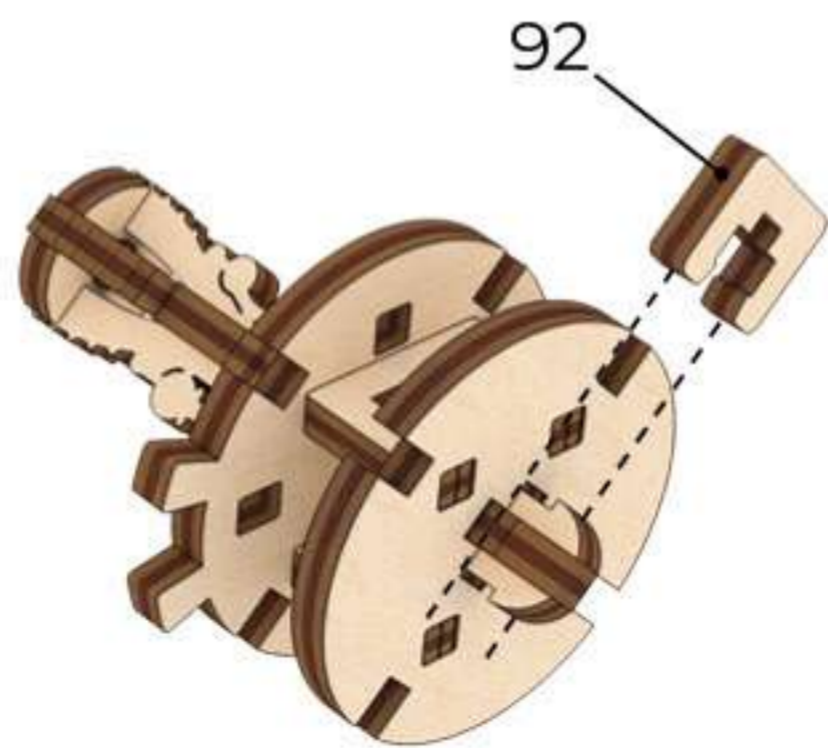

f2

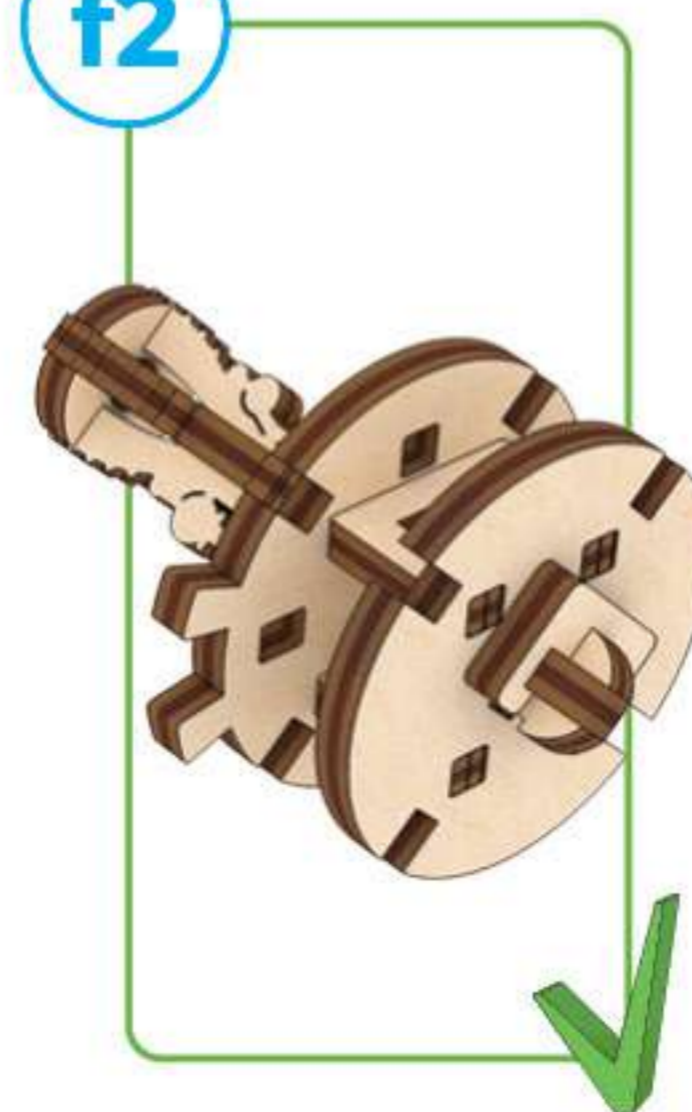

2

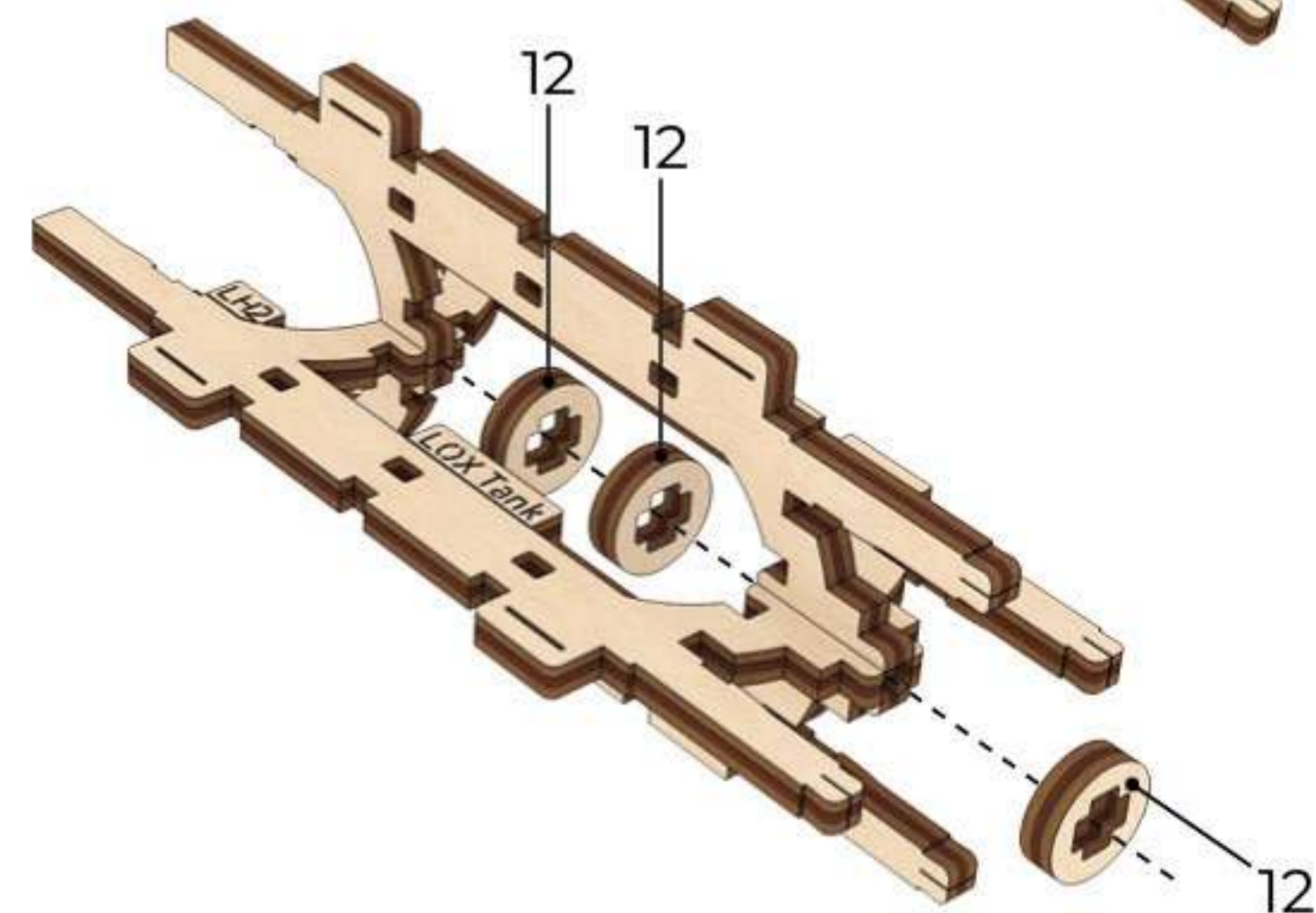

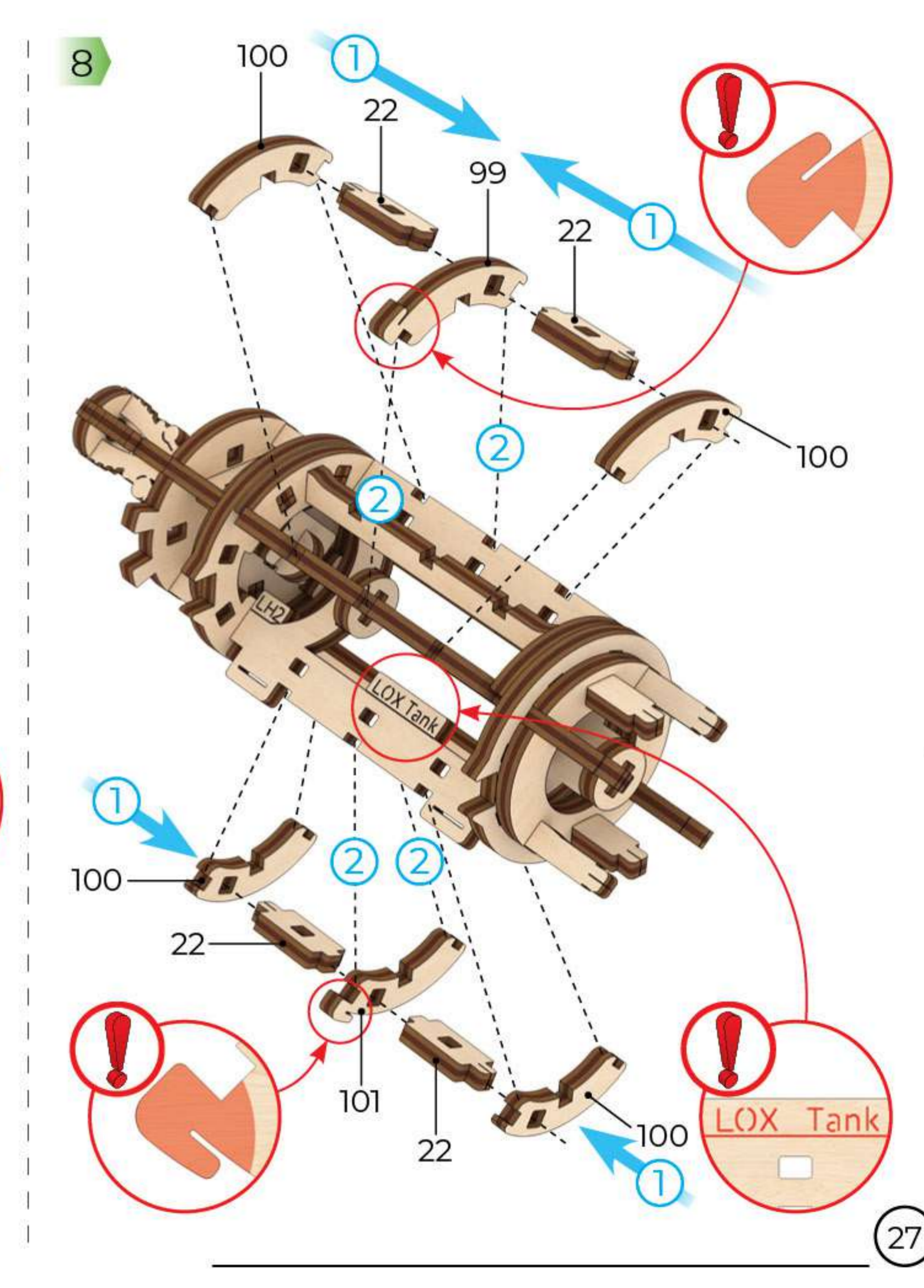
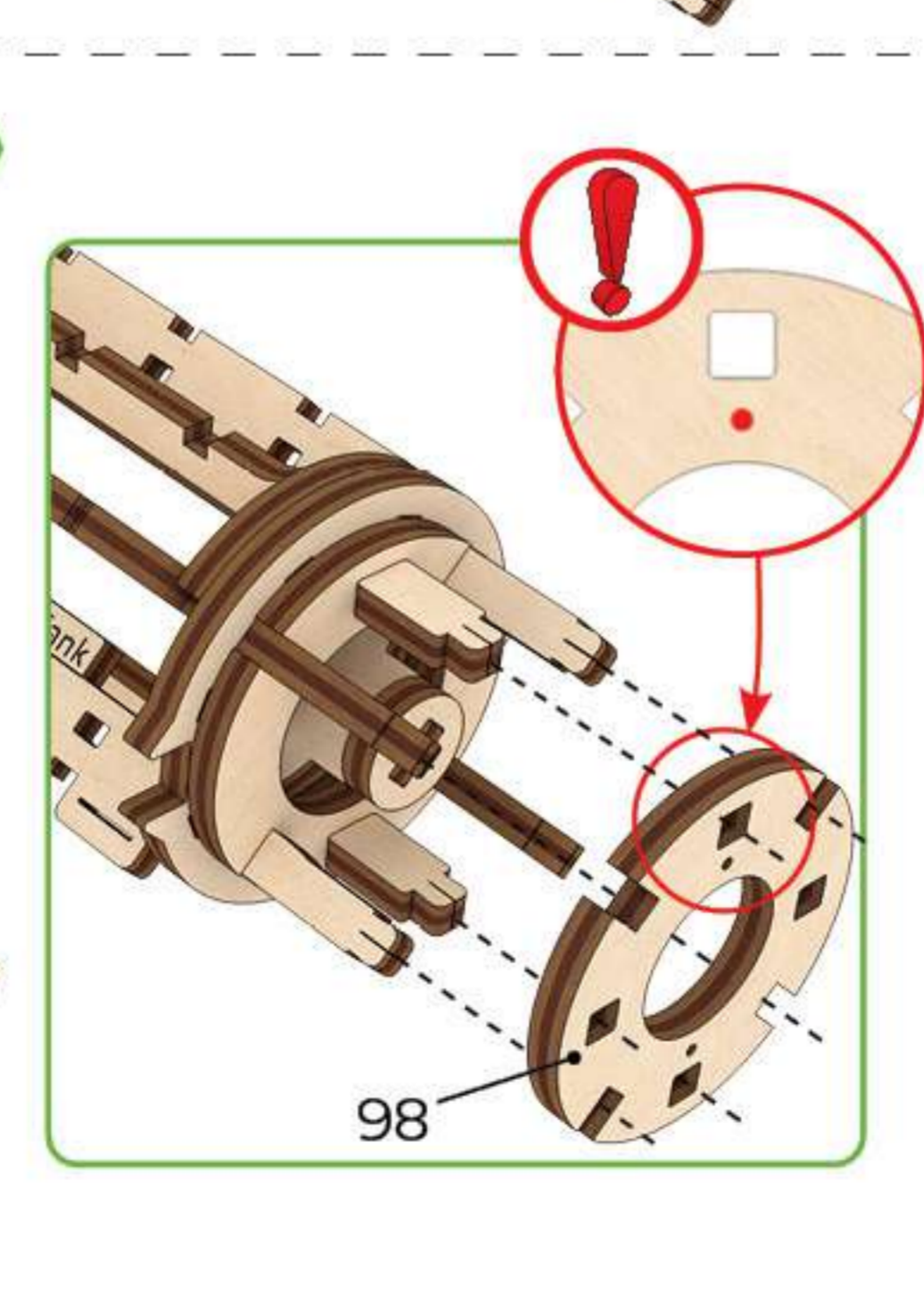
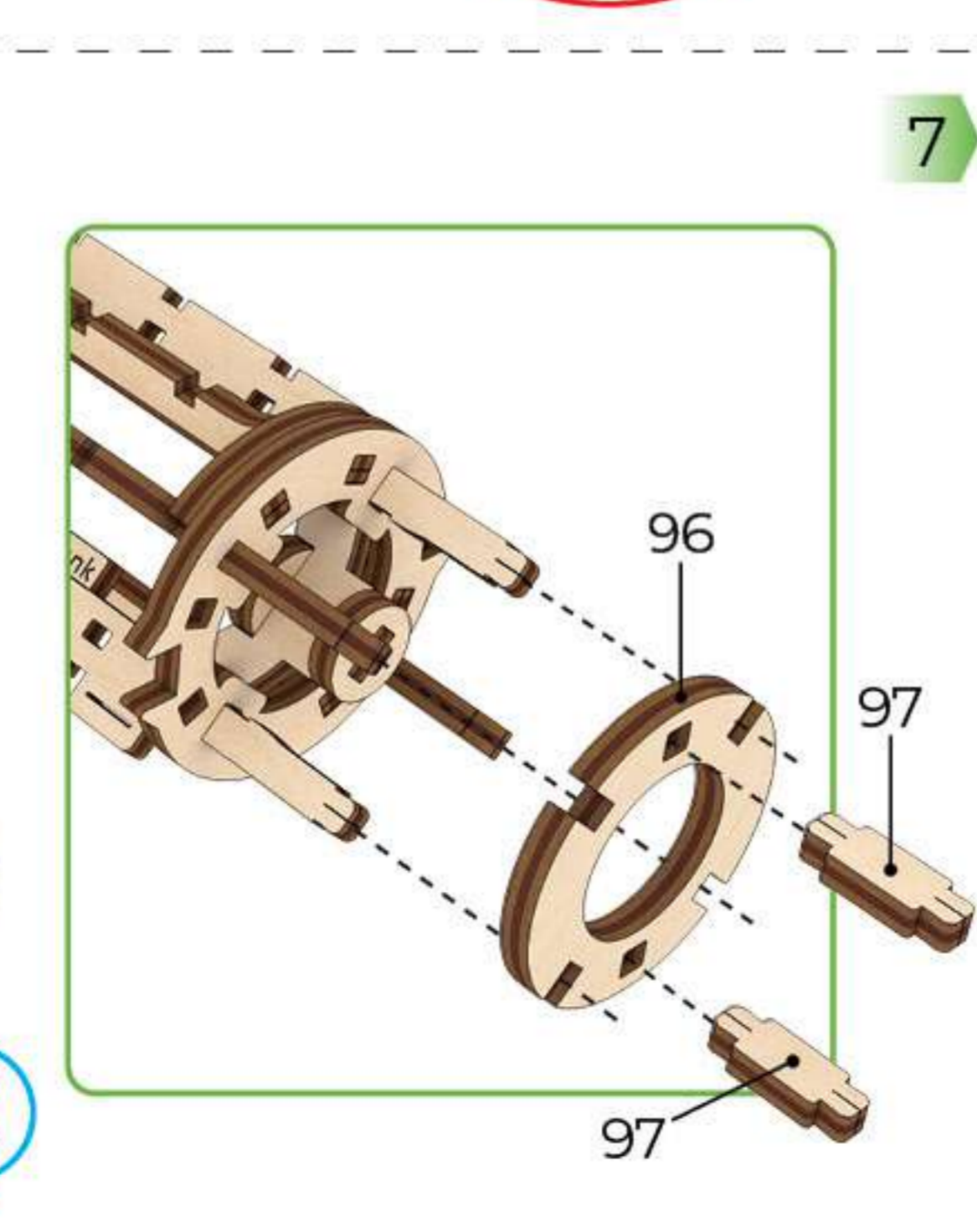
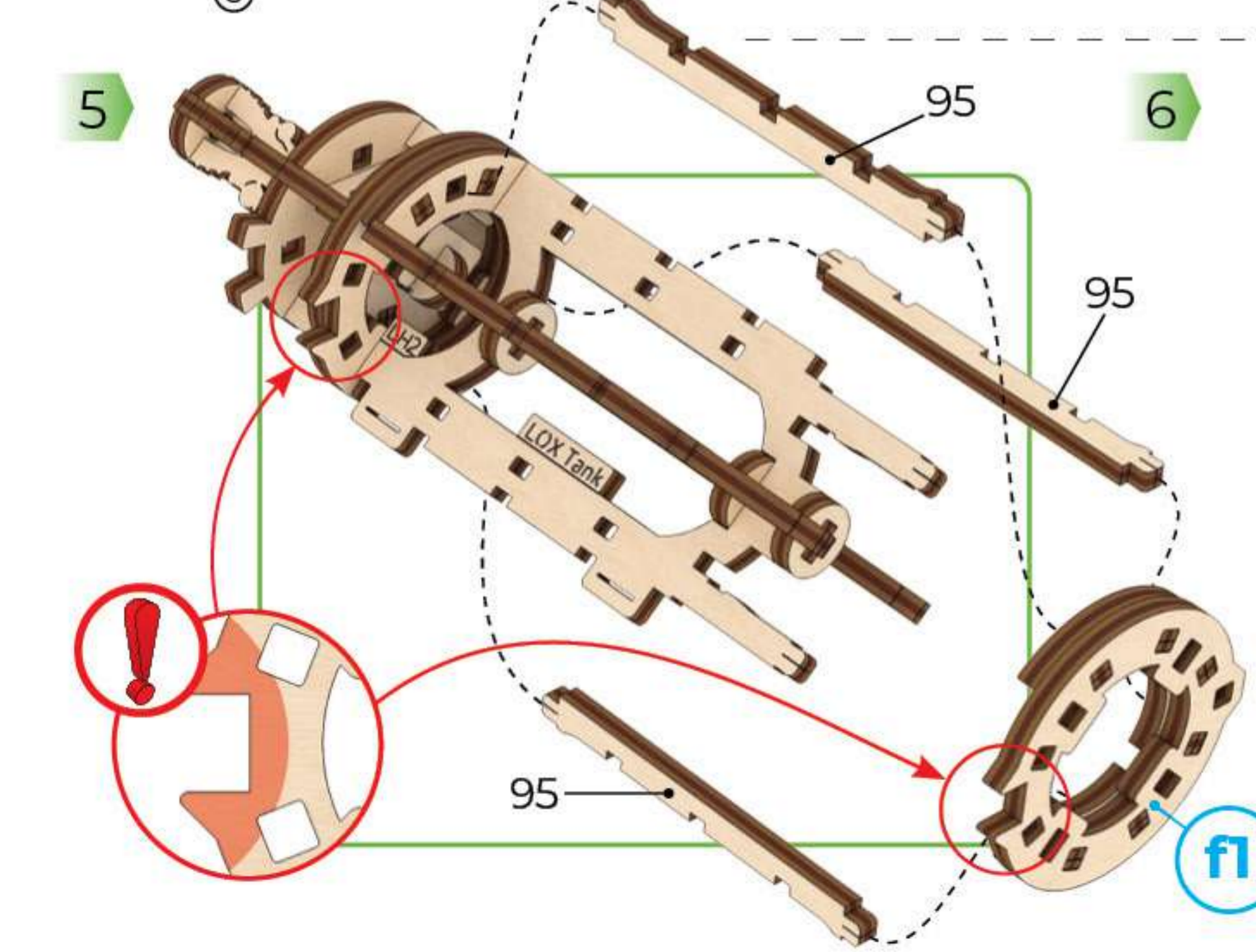
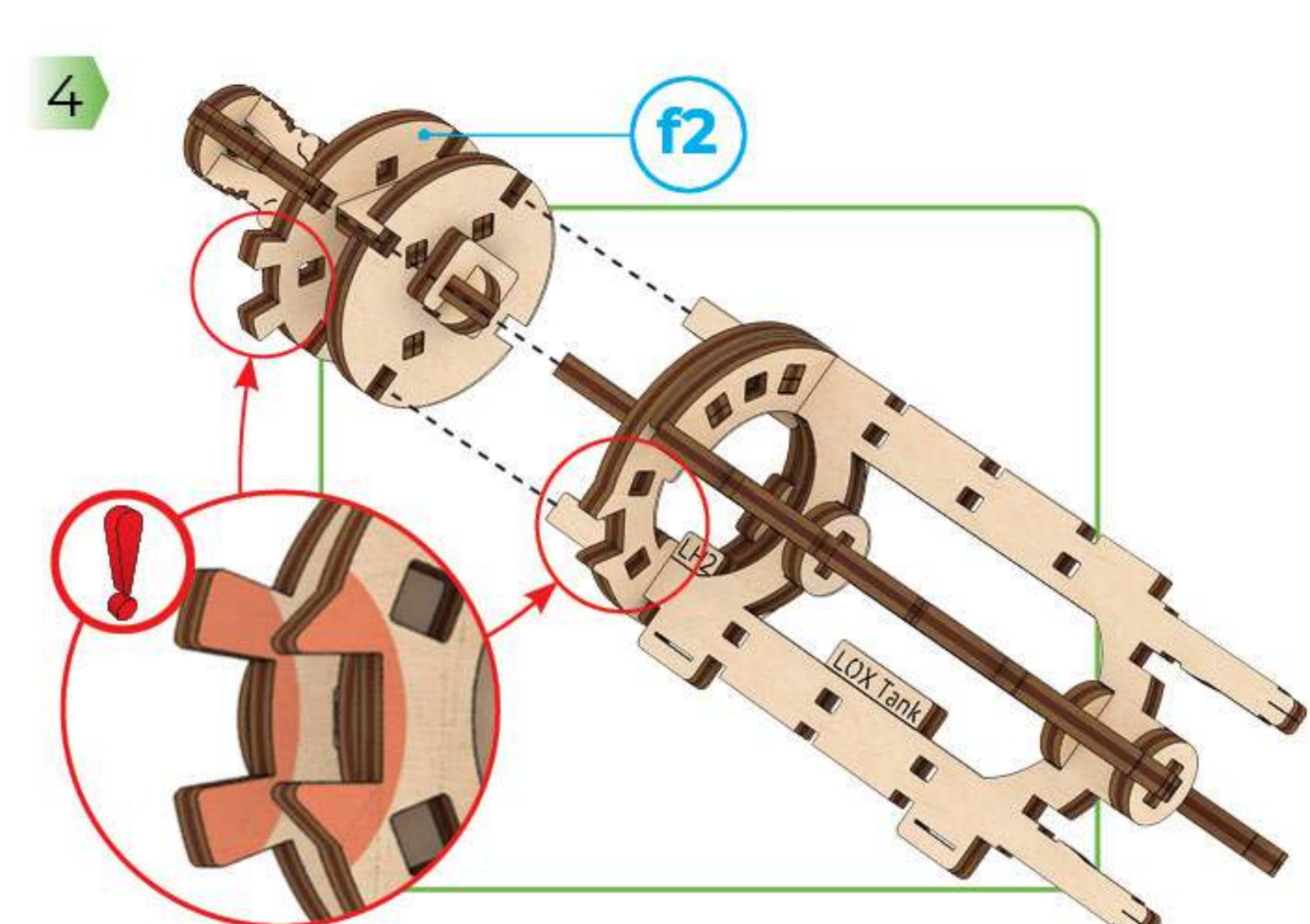
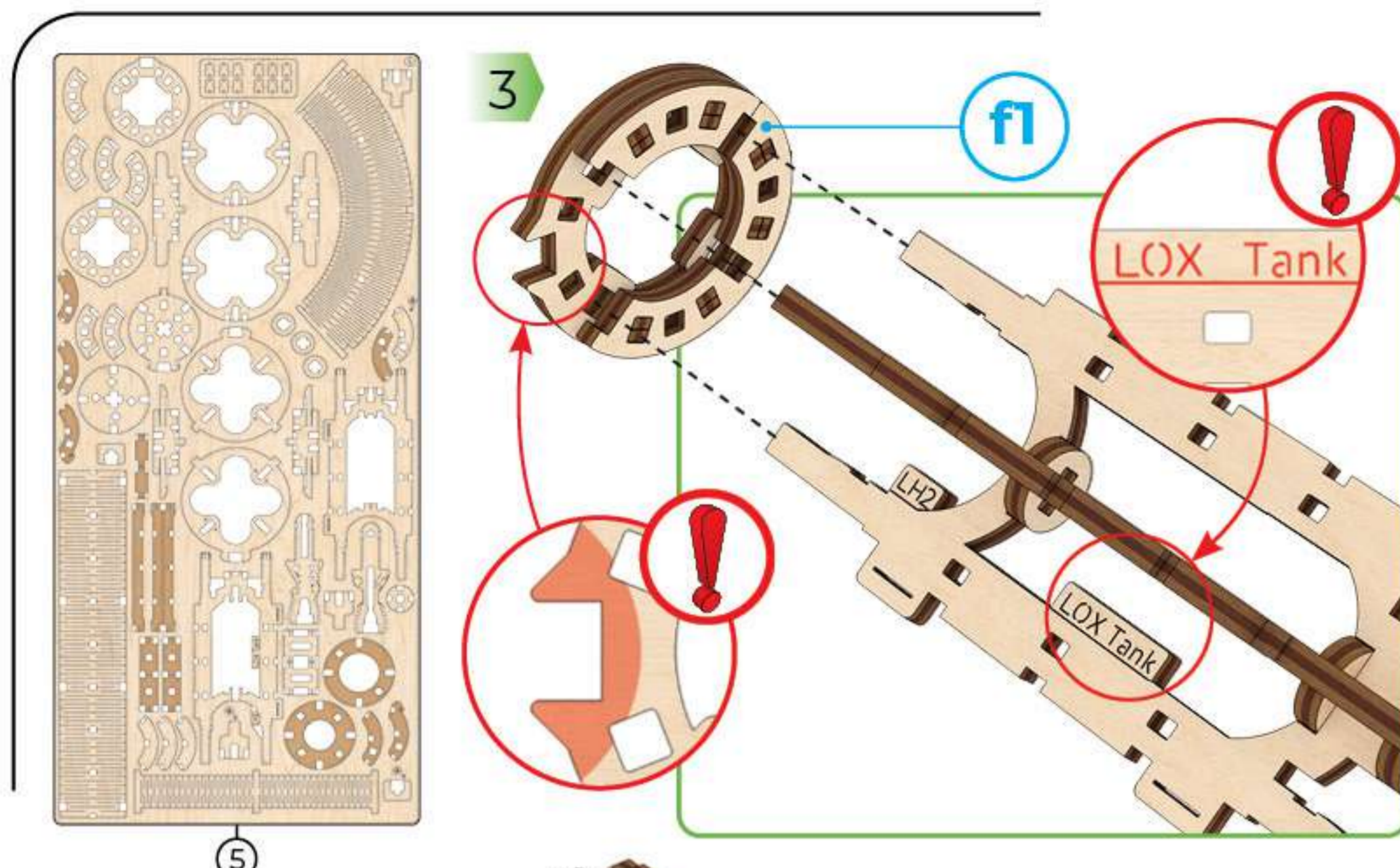

Mechanical models

9

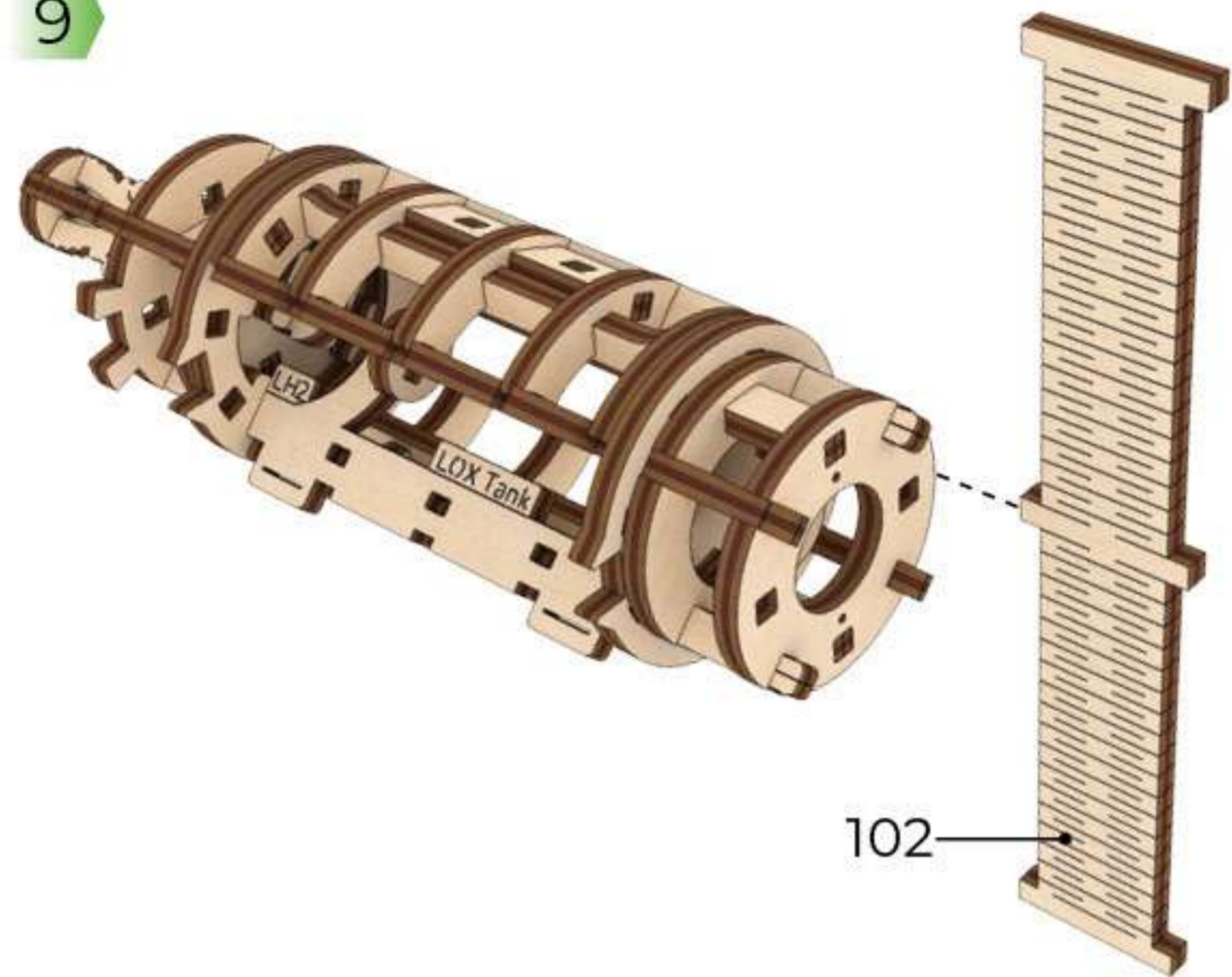

10

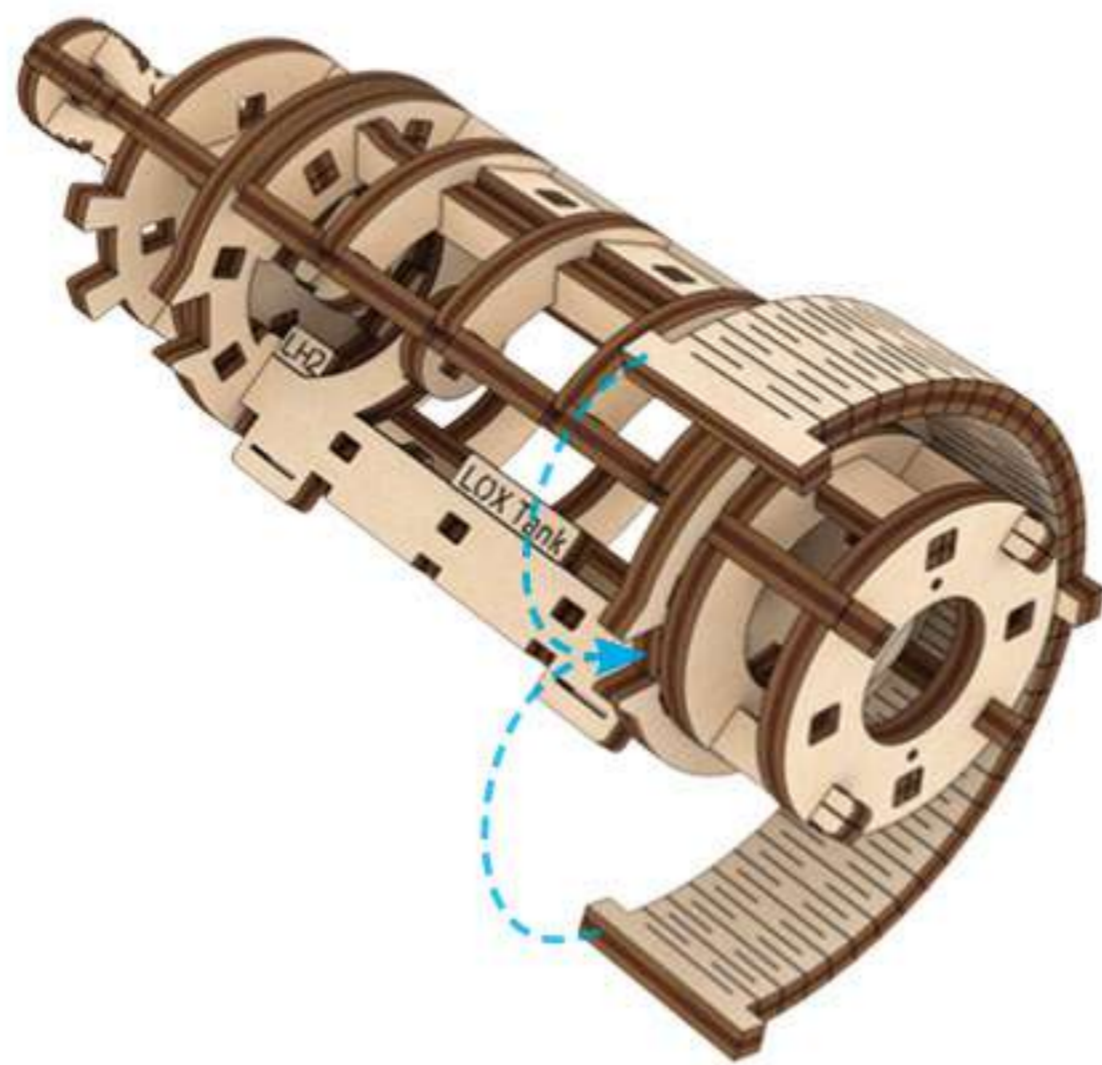

11

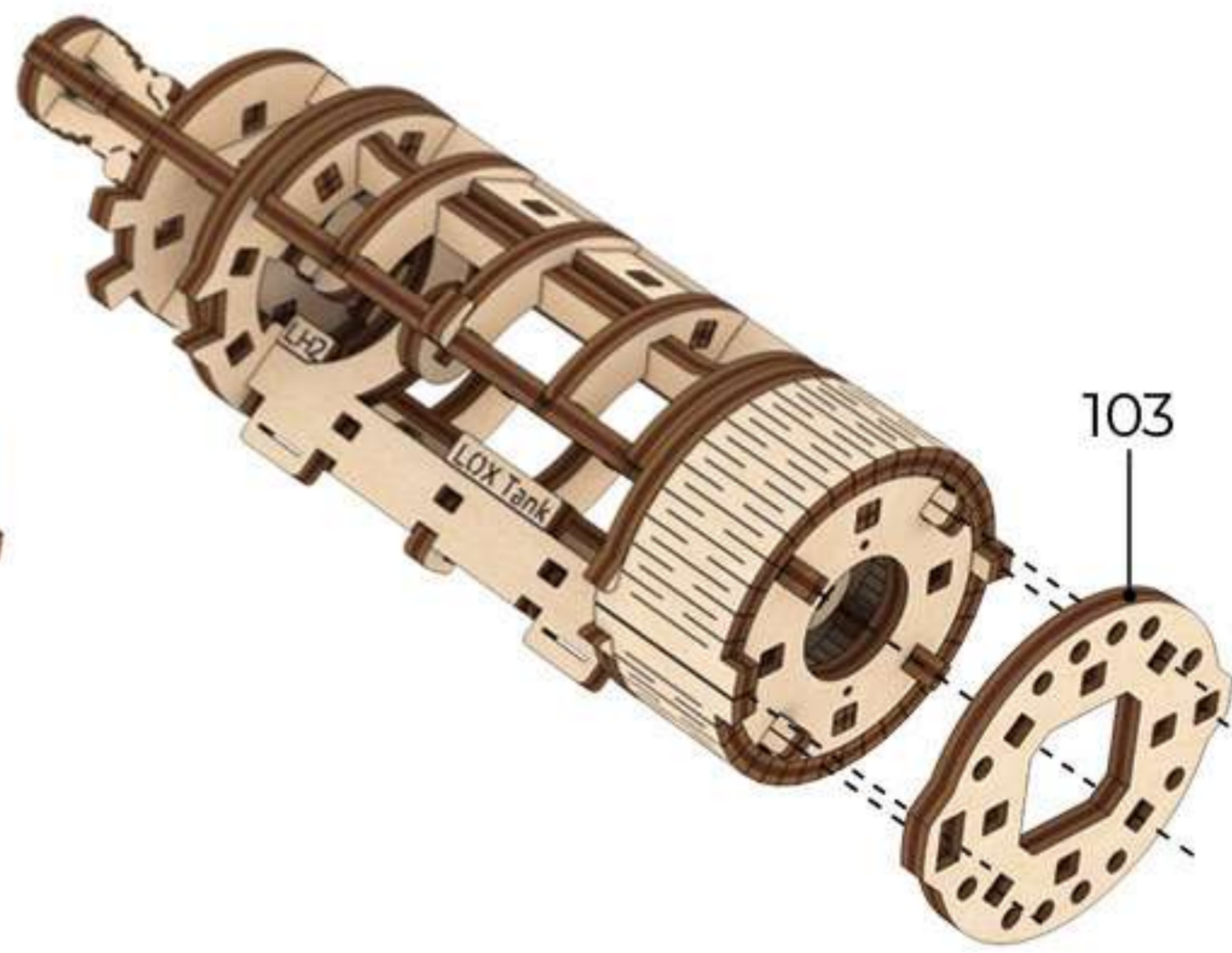

5

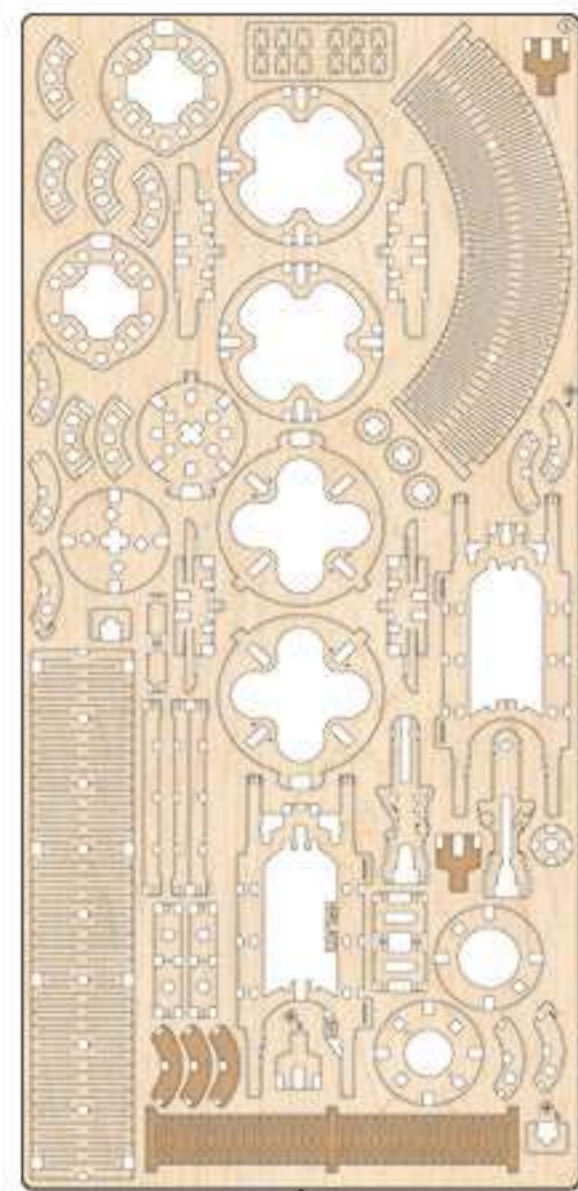

12

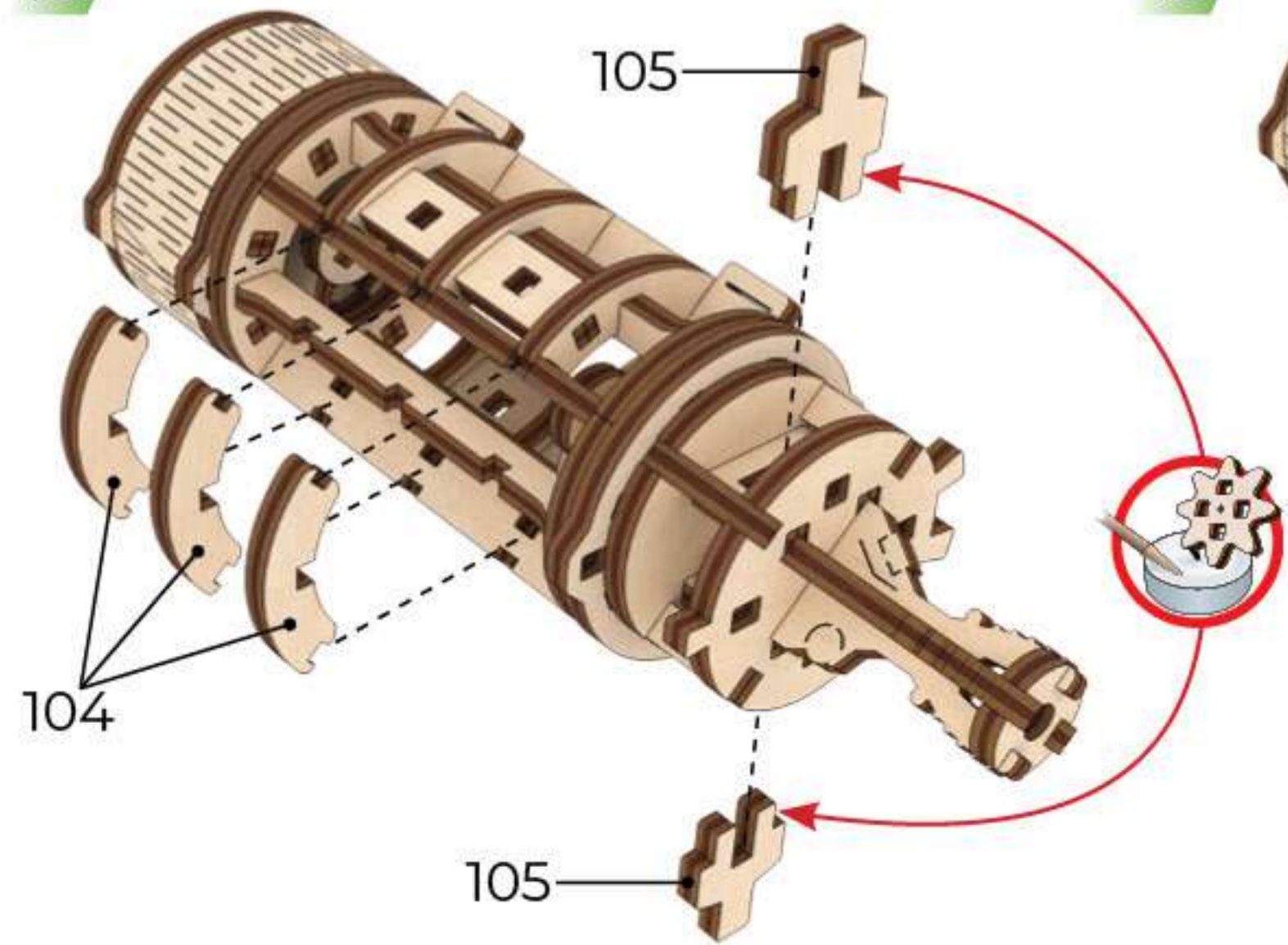

13

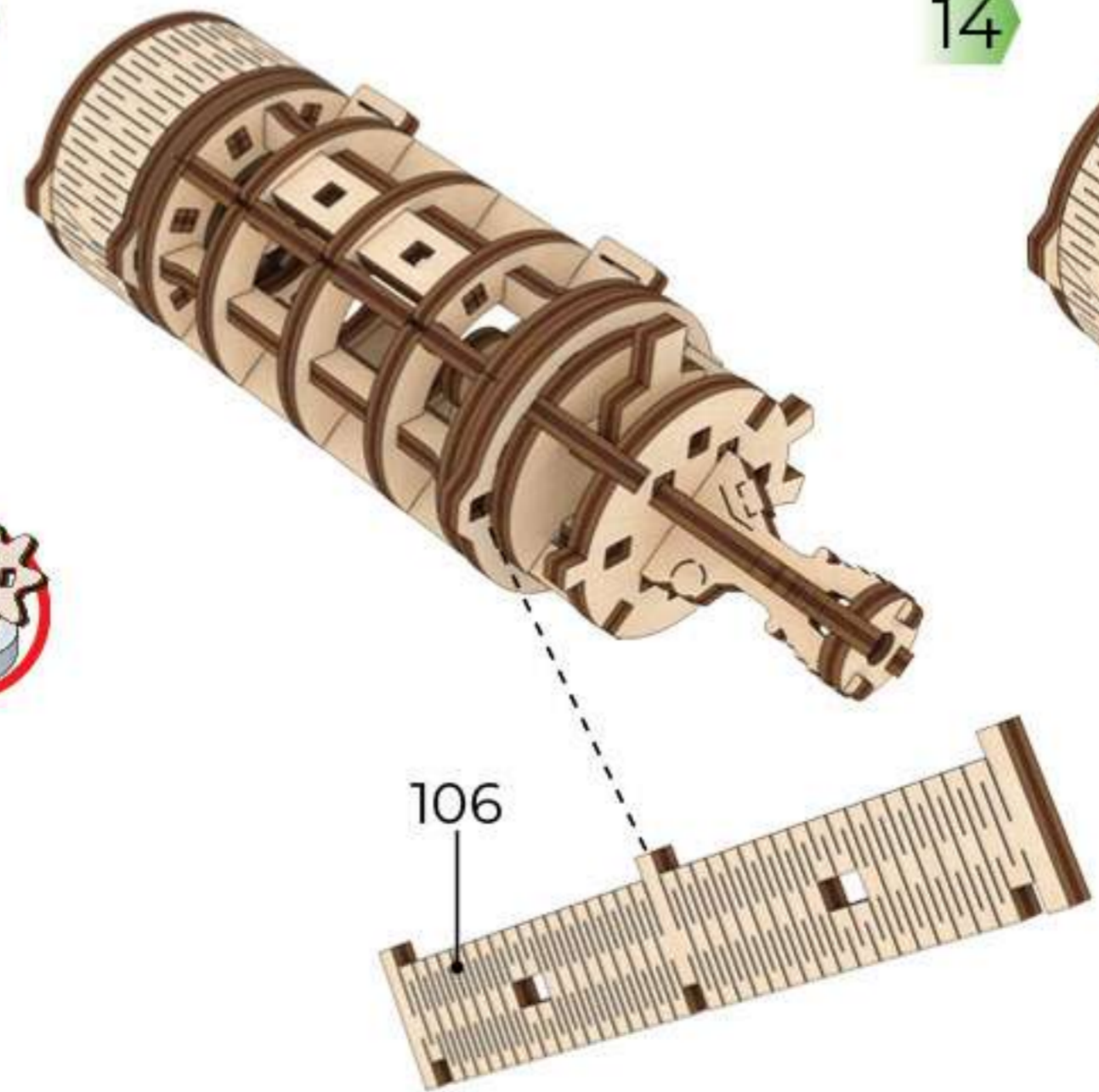

14

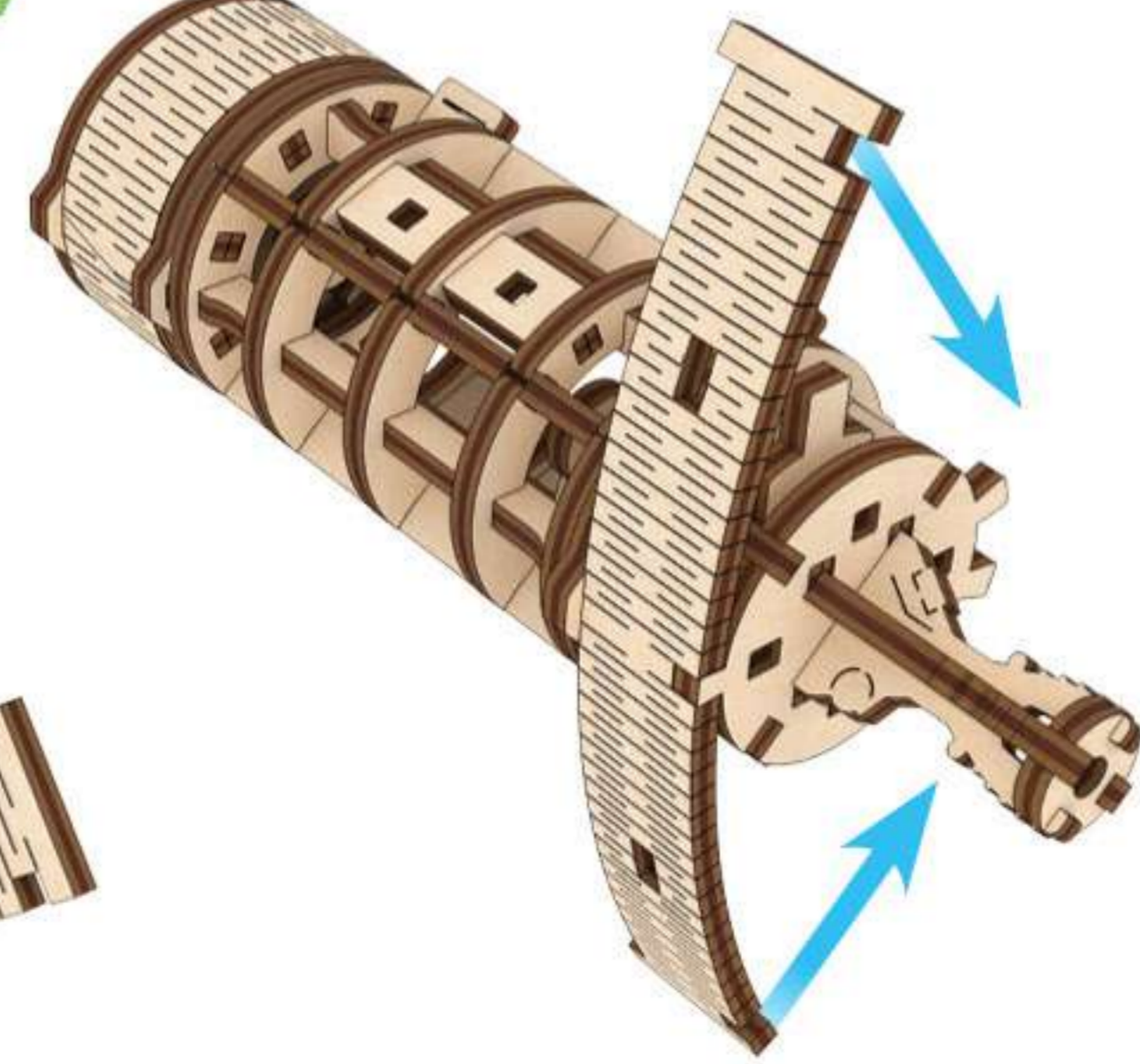

6

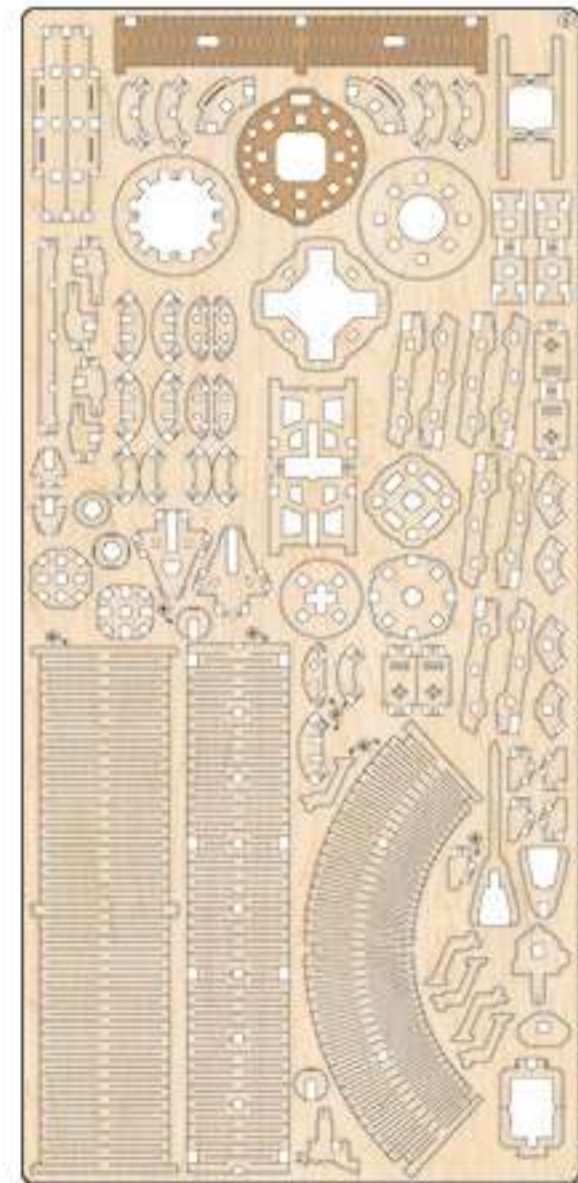

15

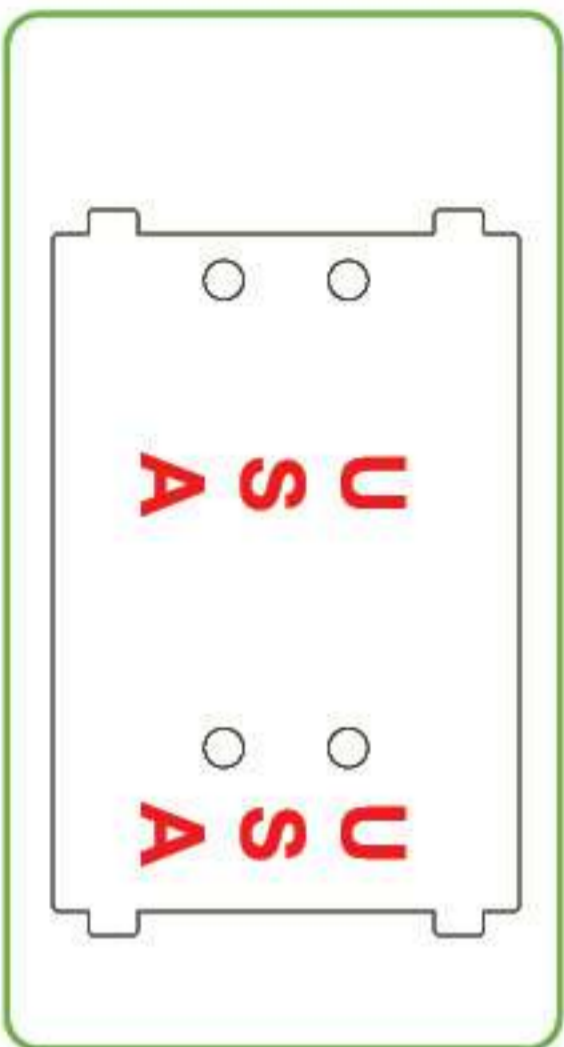

16

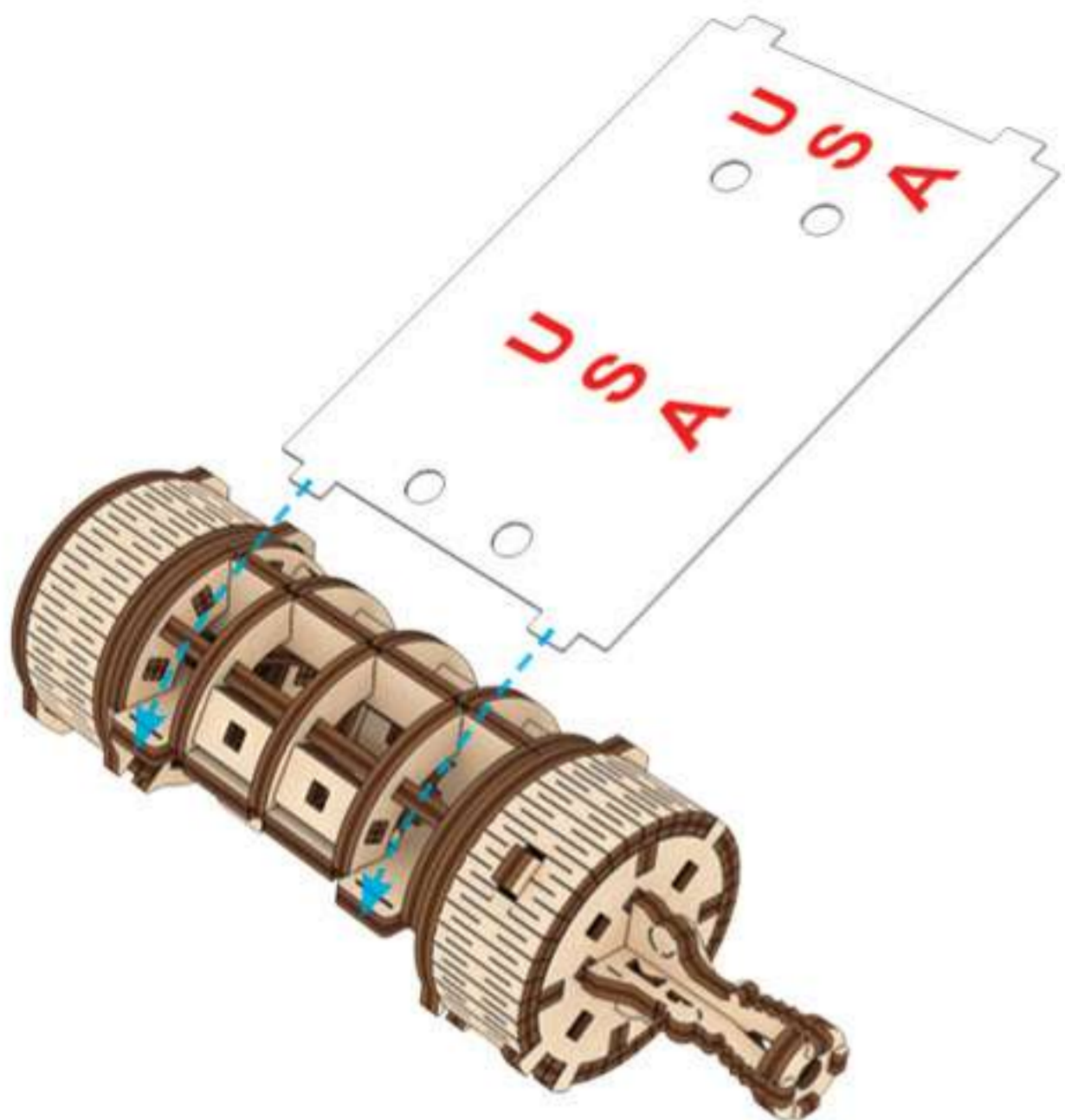

17

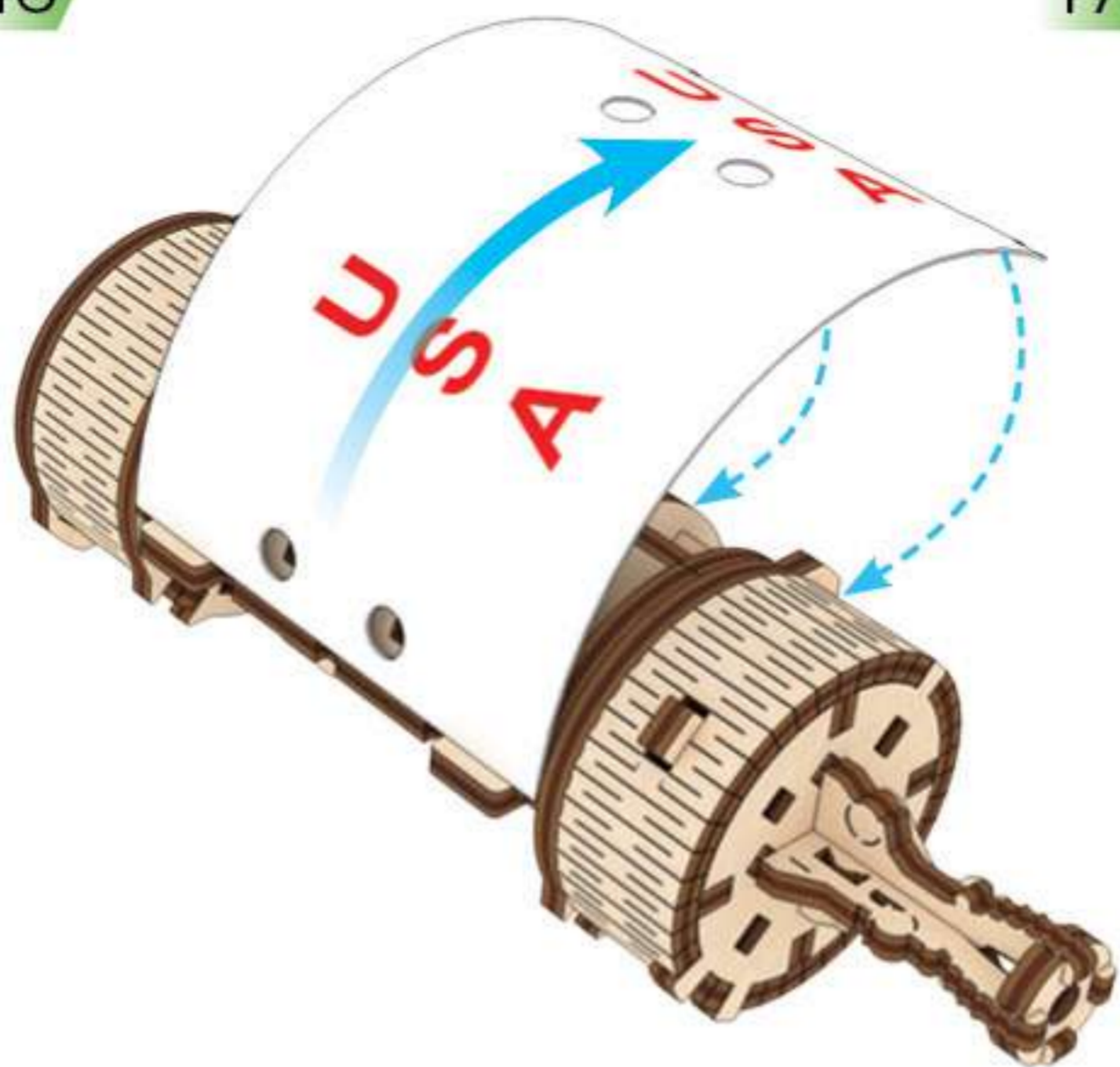

107

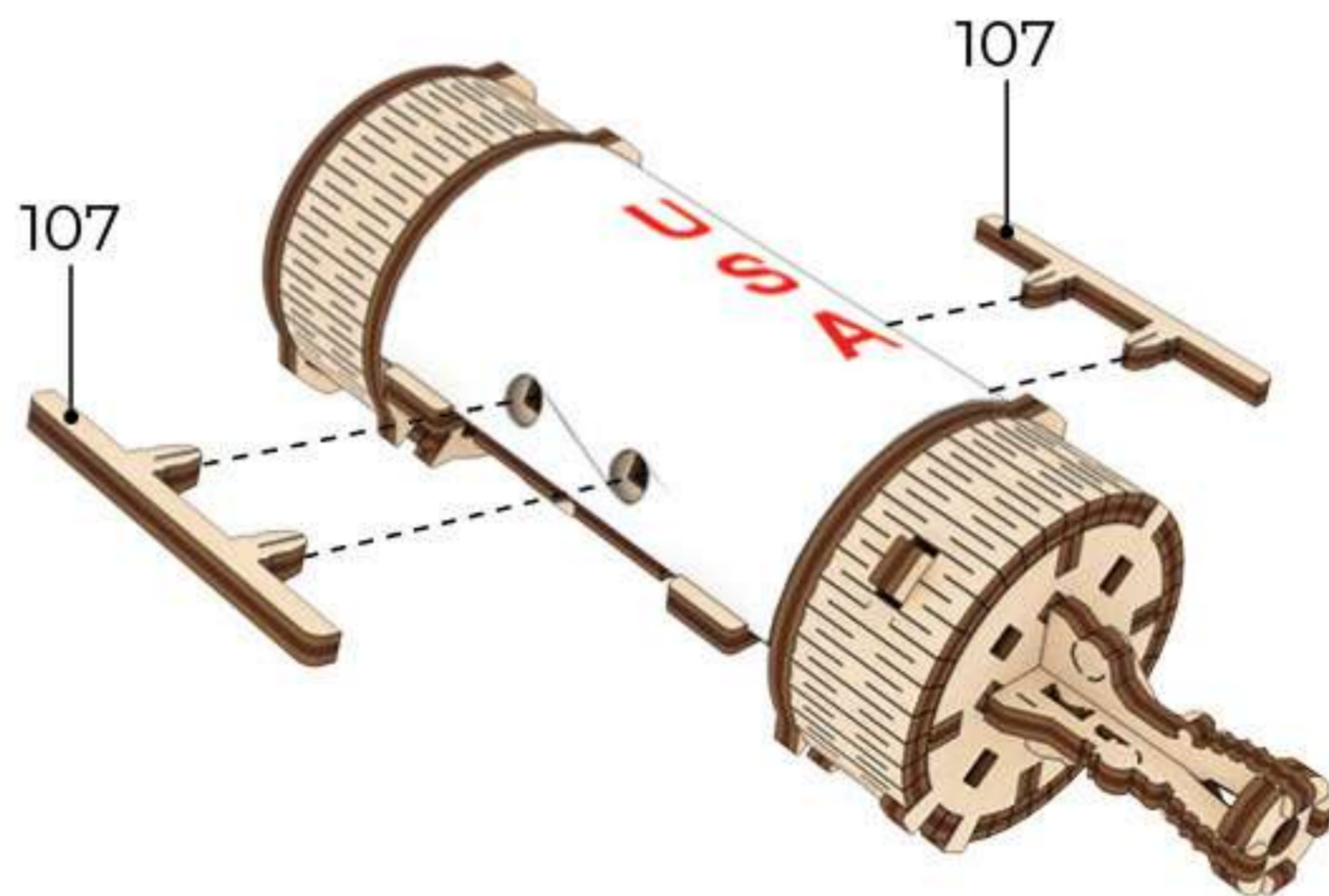

f3

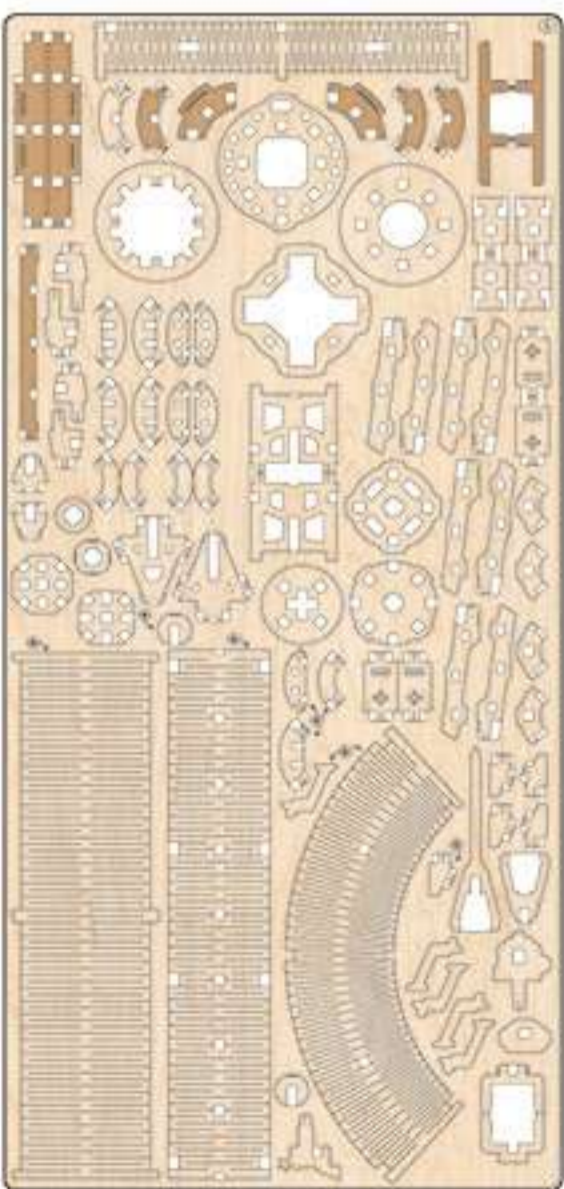

6

1

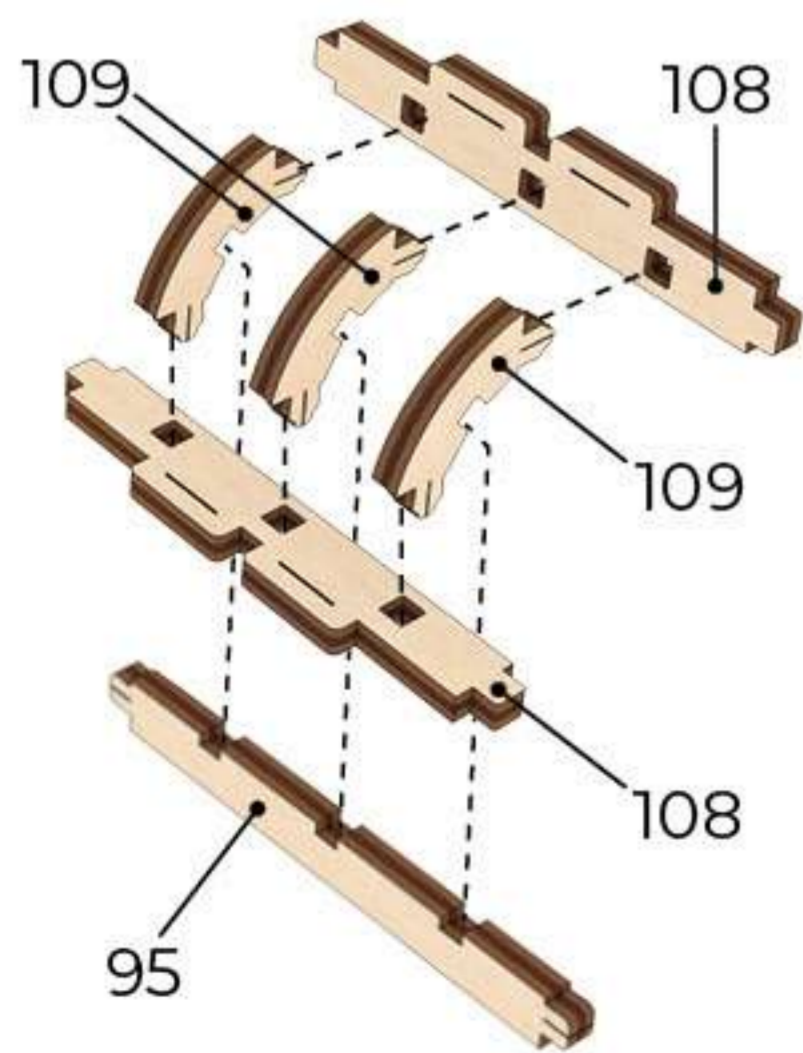

2

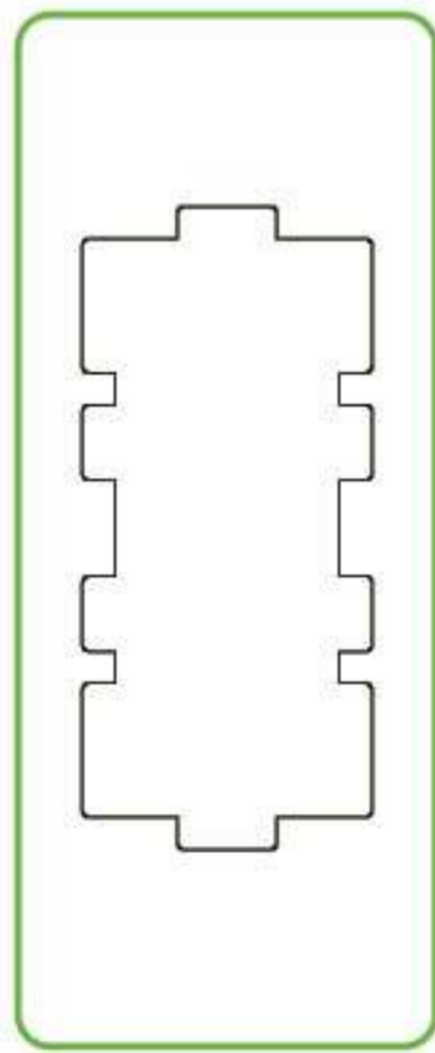

3

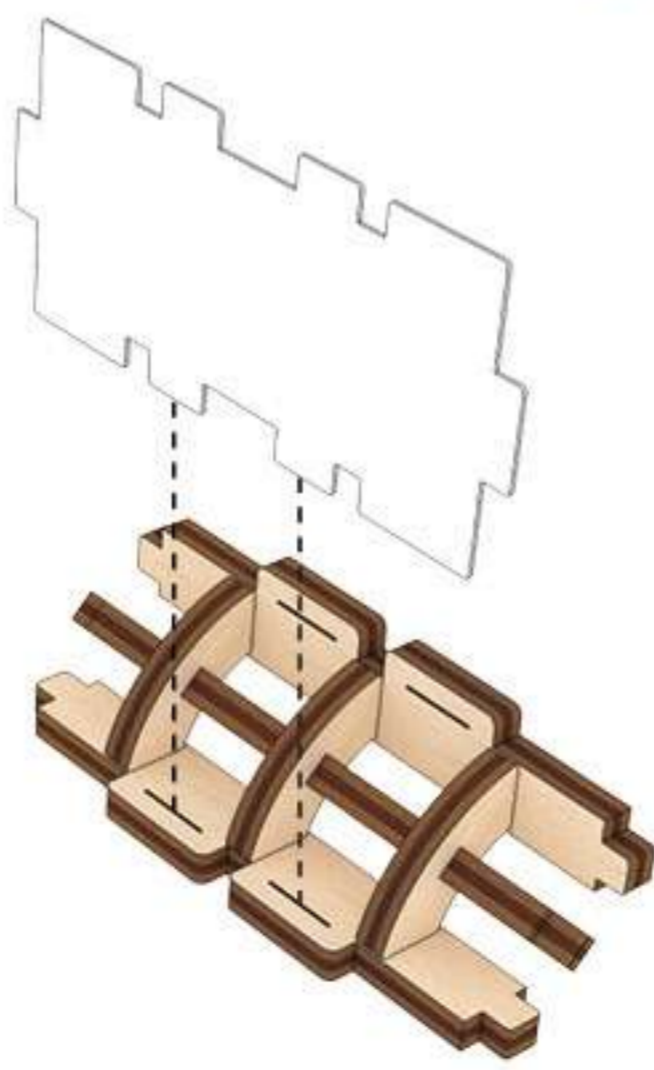

4

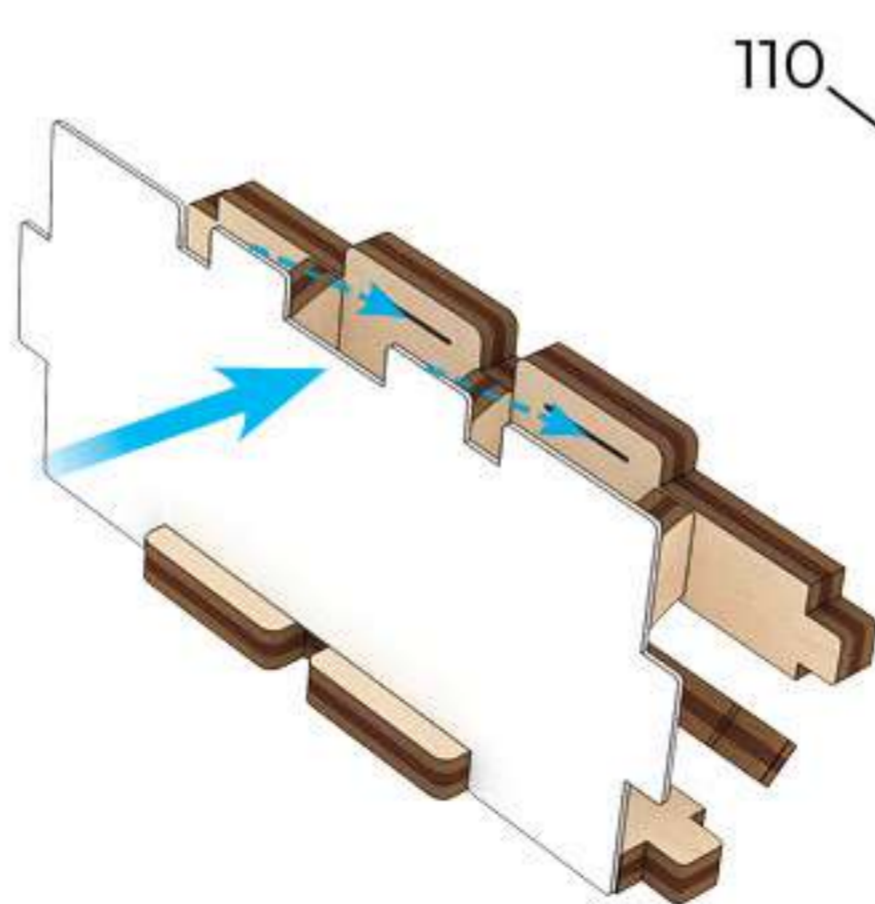

110

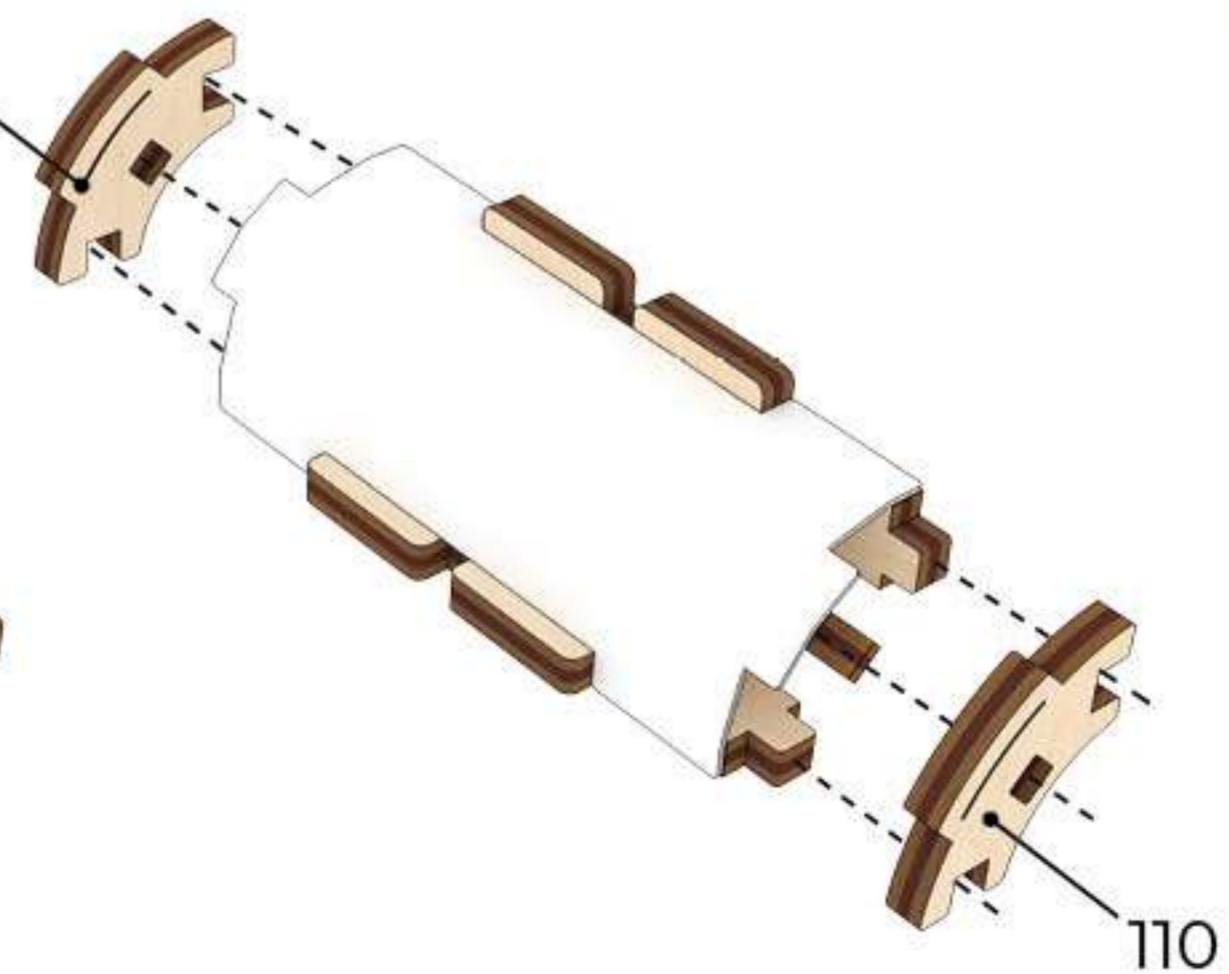

f4

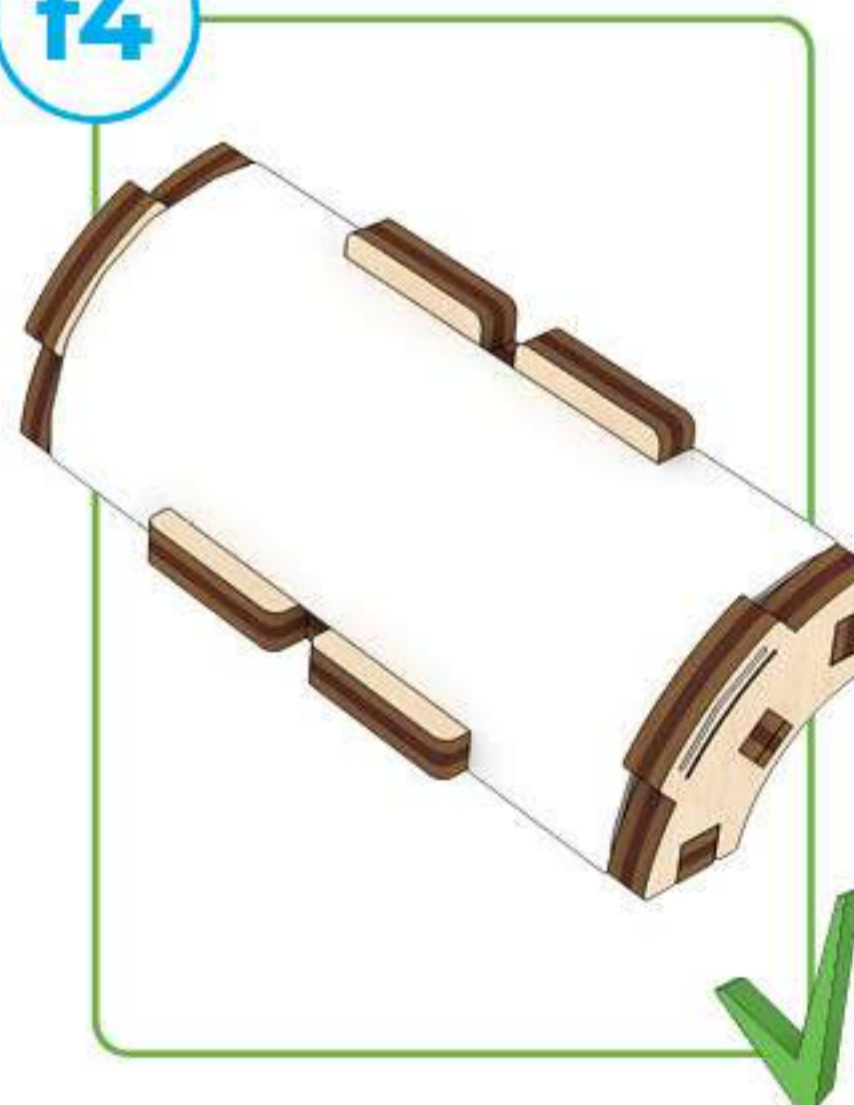

1

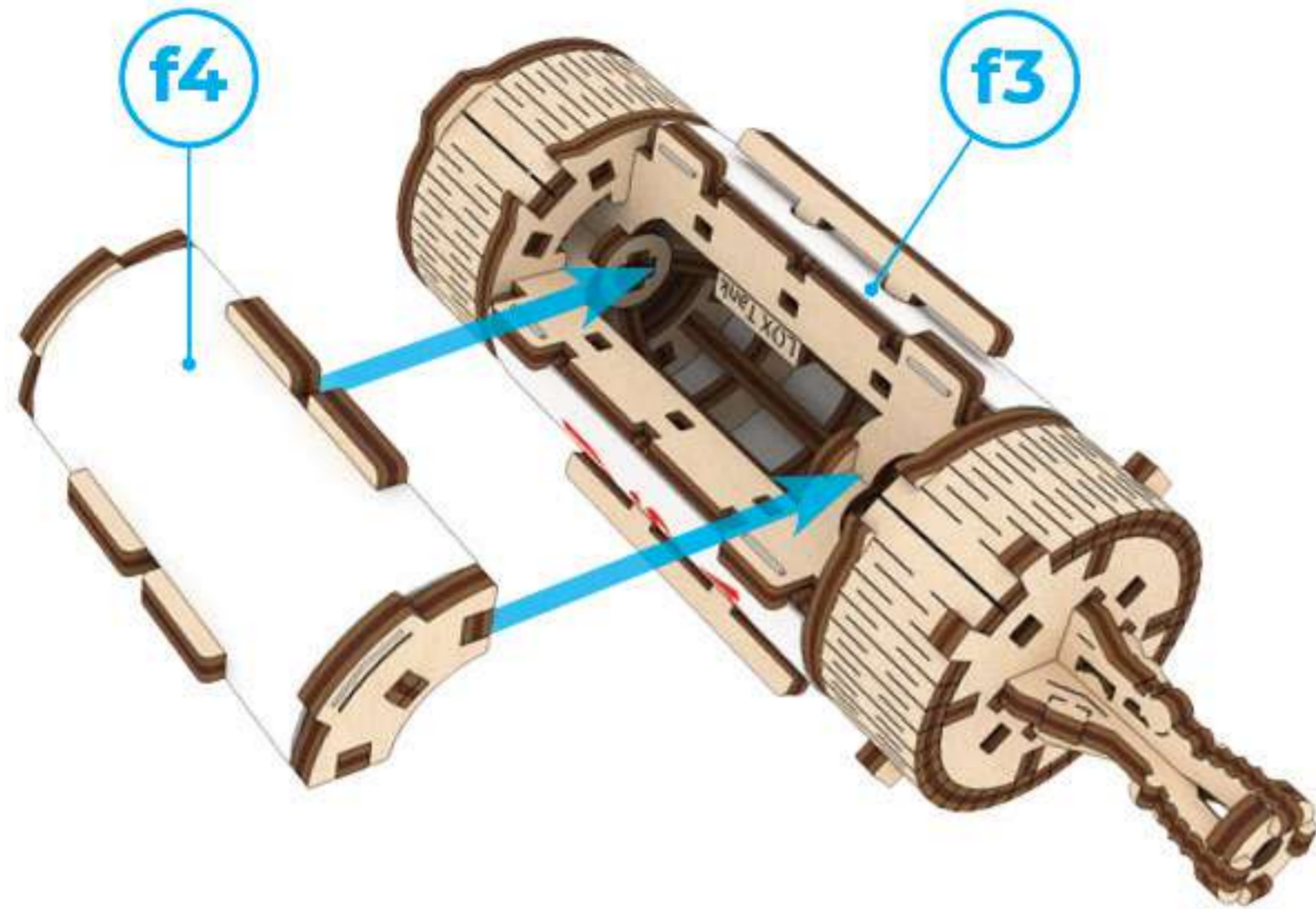

F

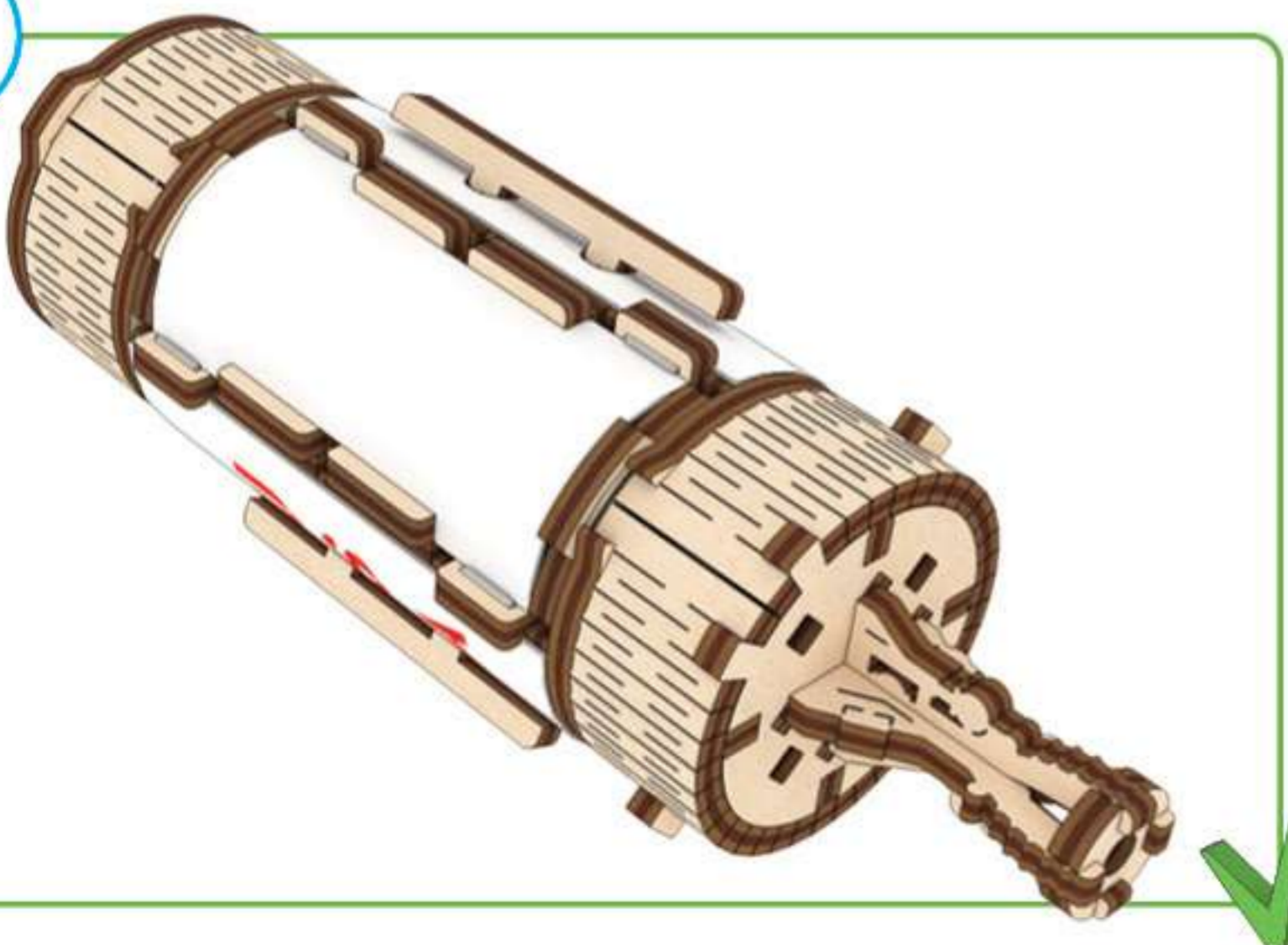

1

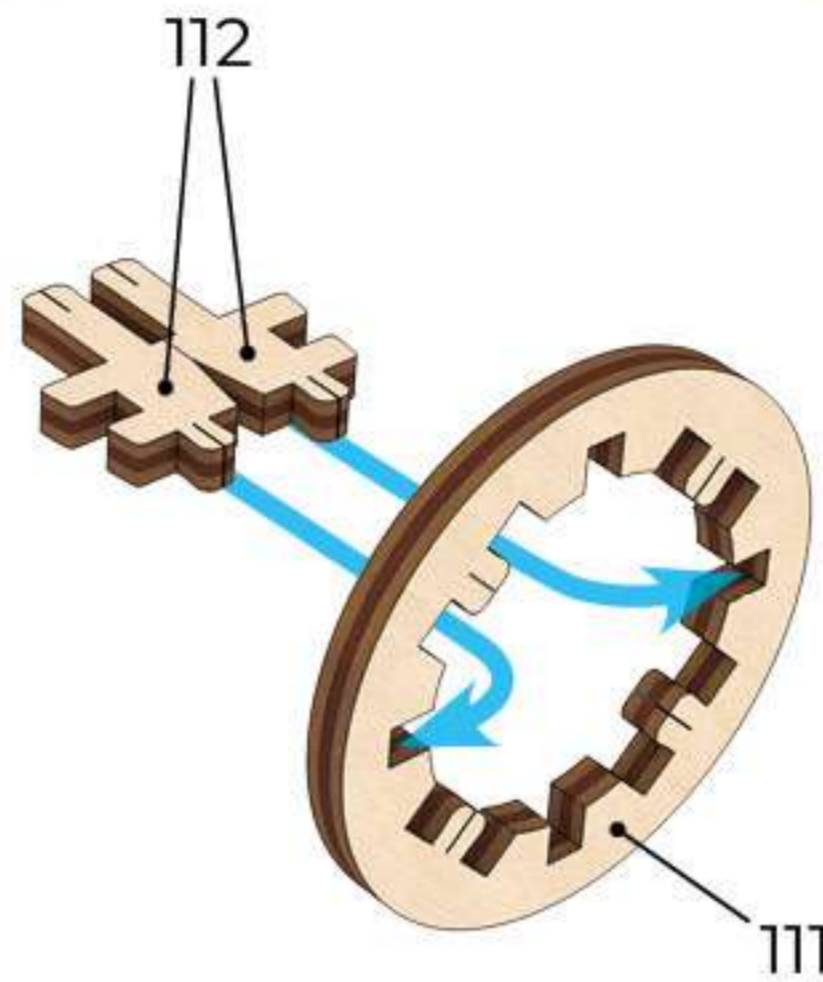

2

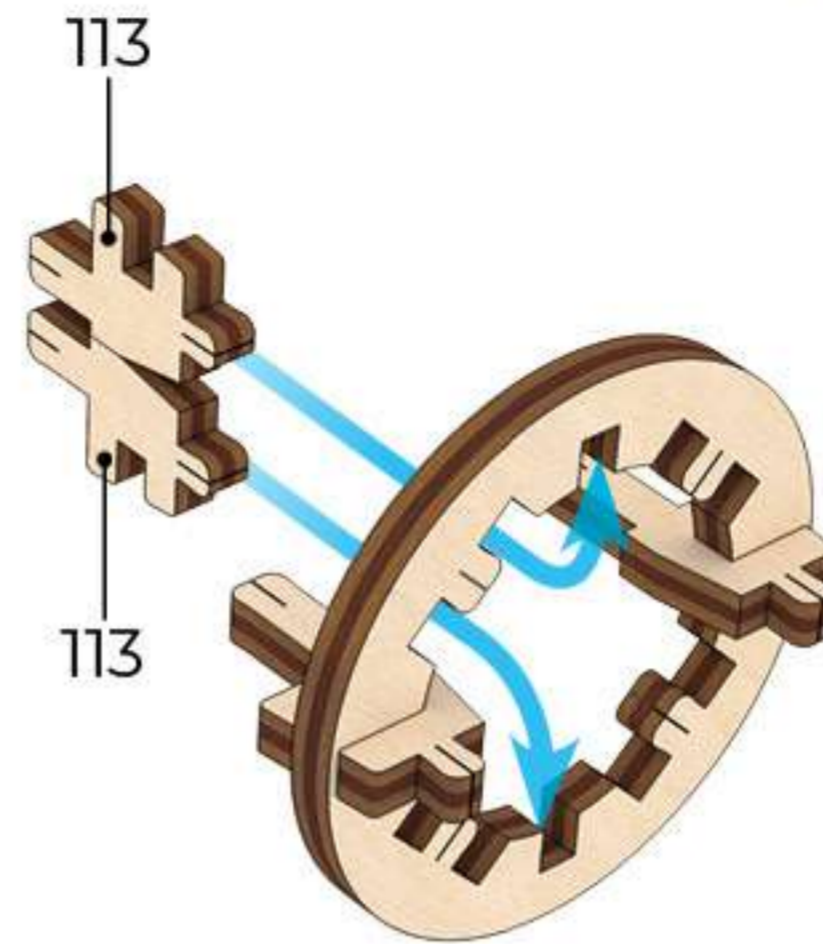

3

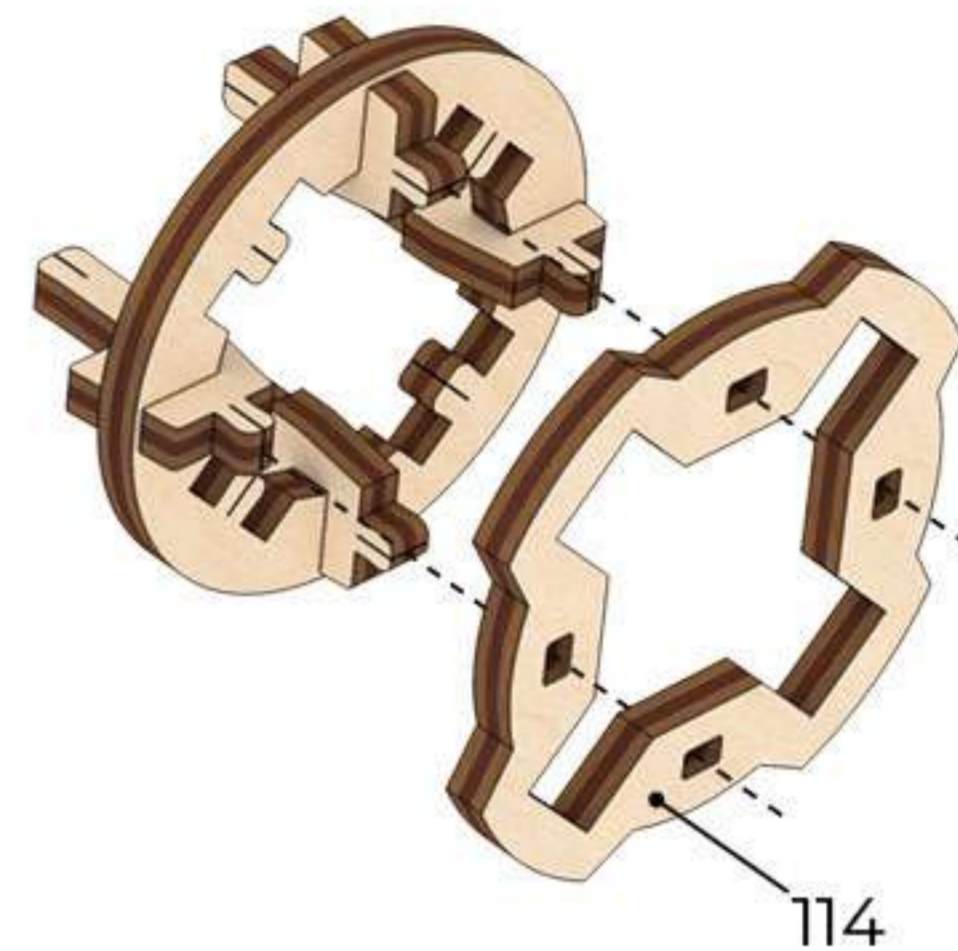

g1

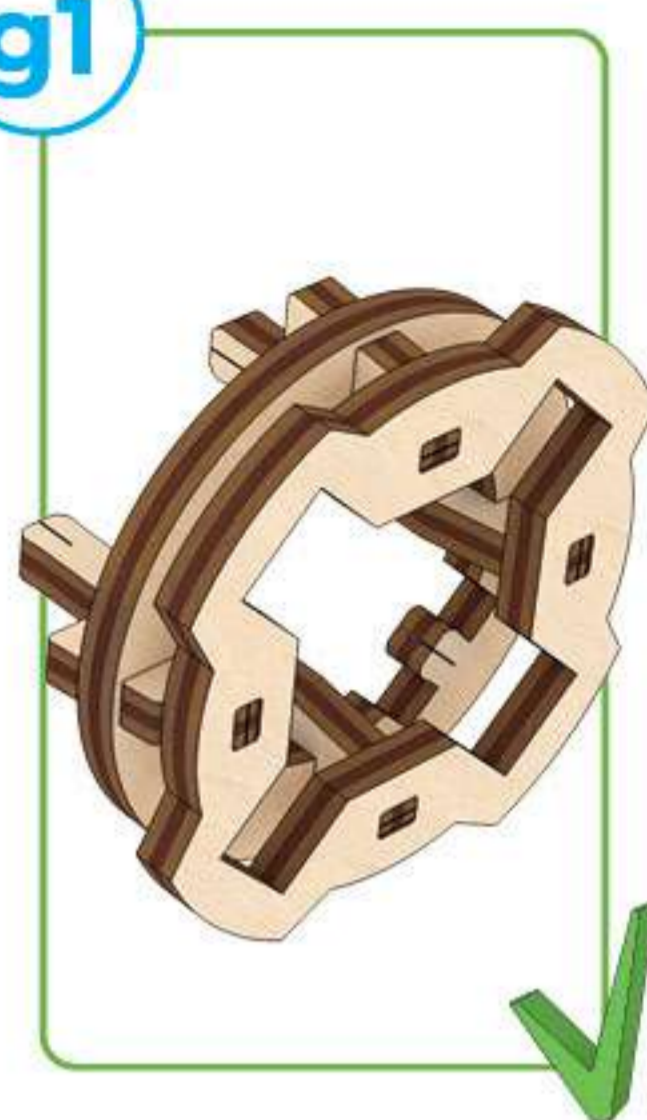

1

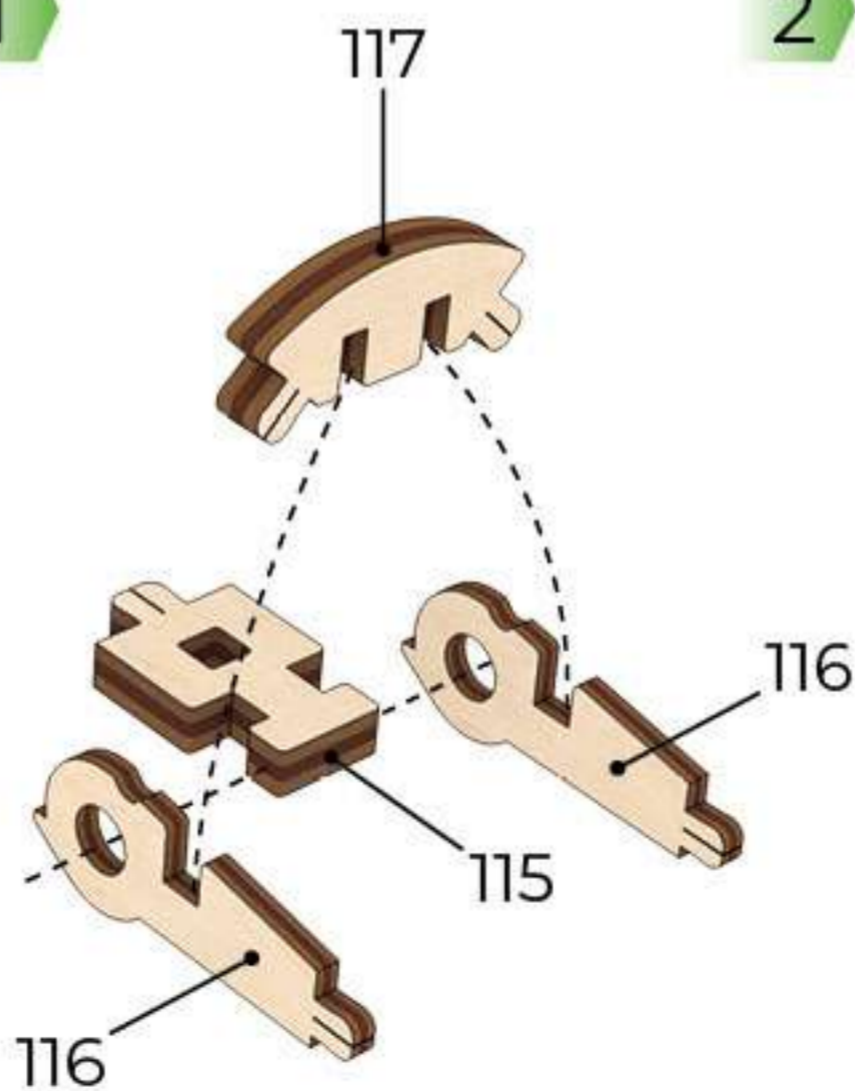

2

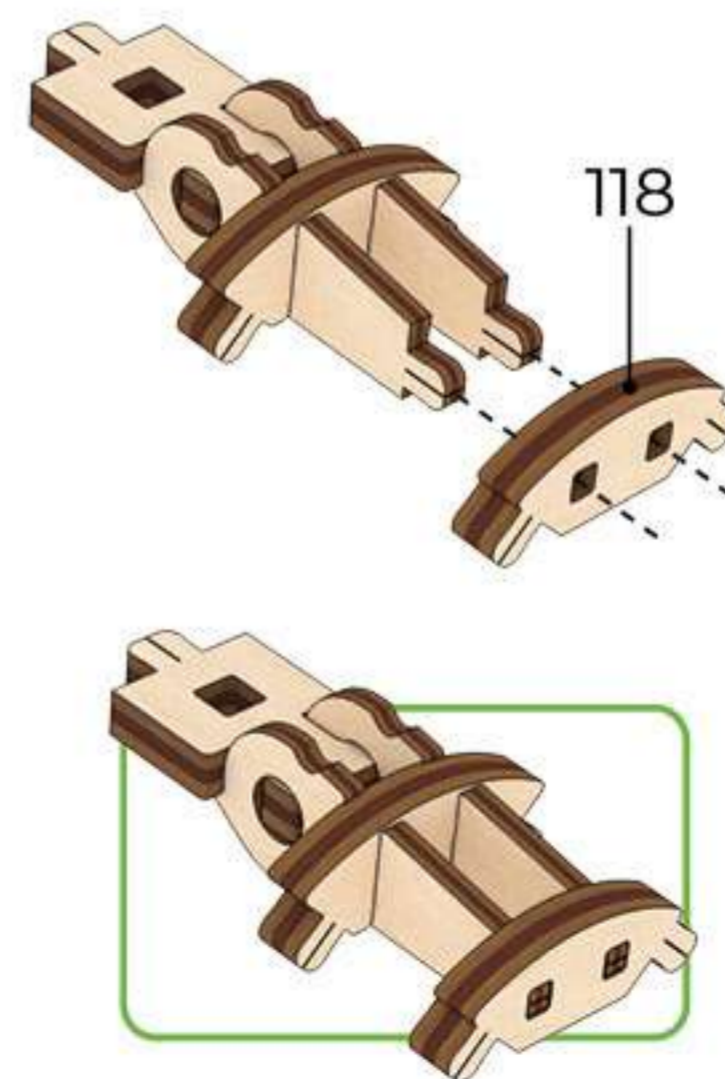

3

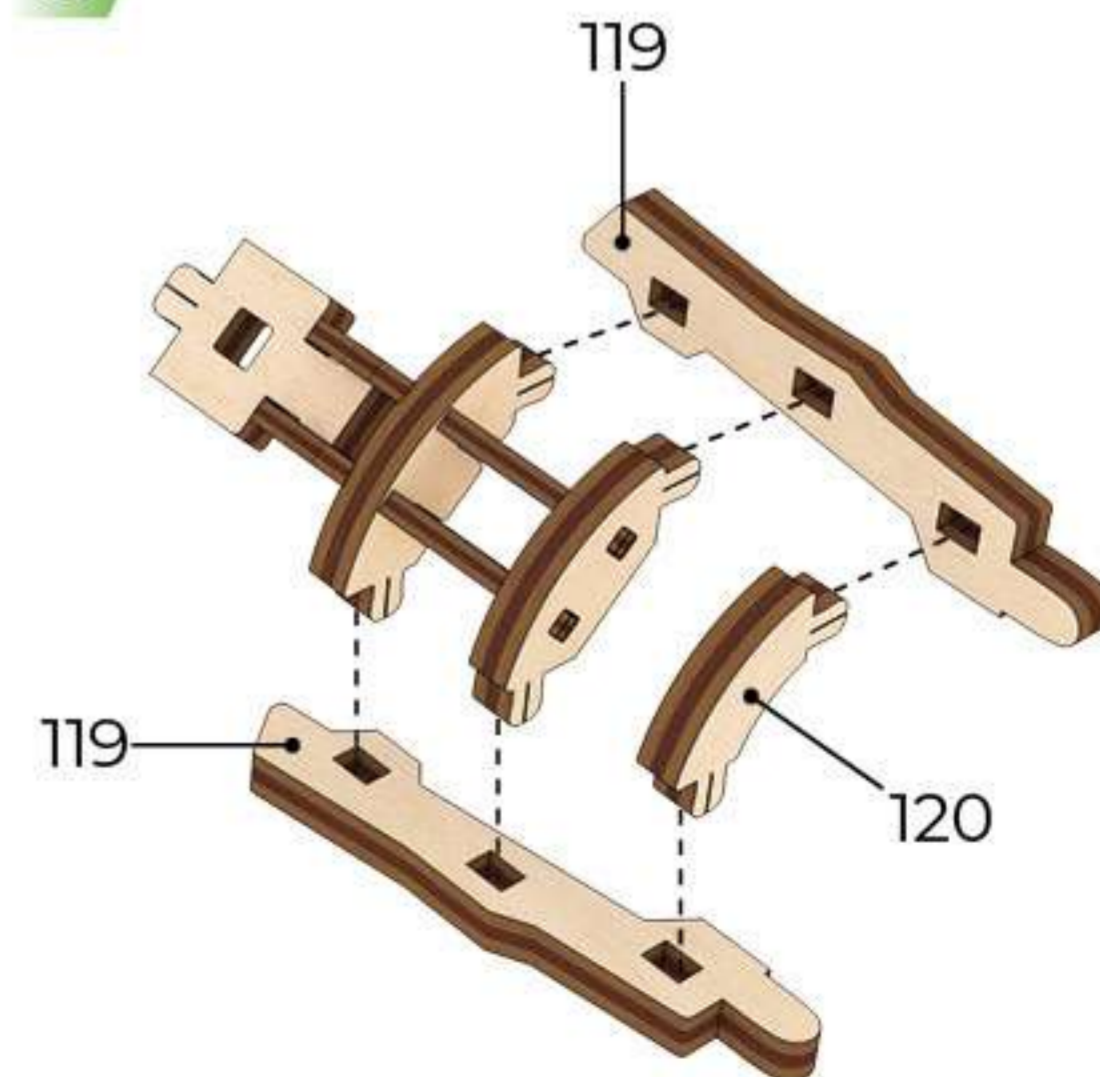

g2

x4

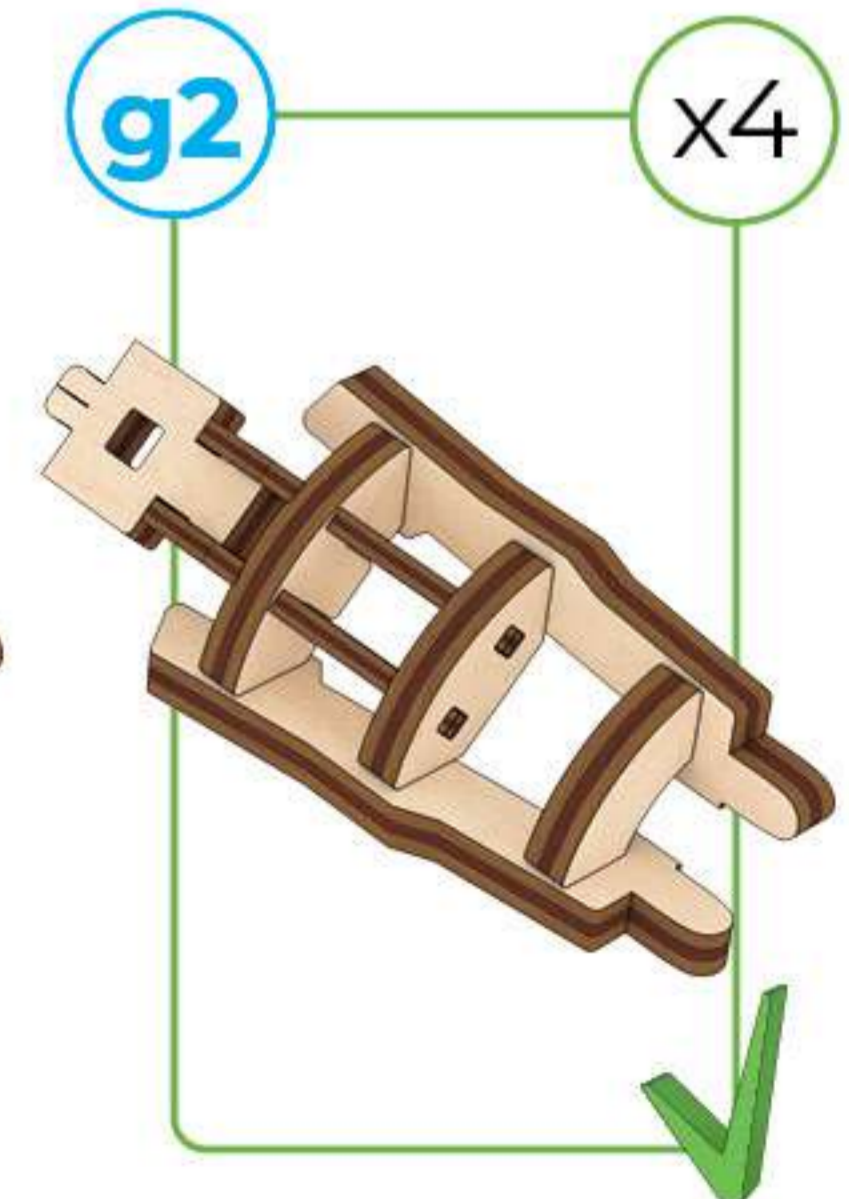

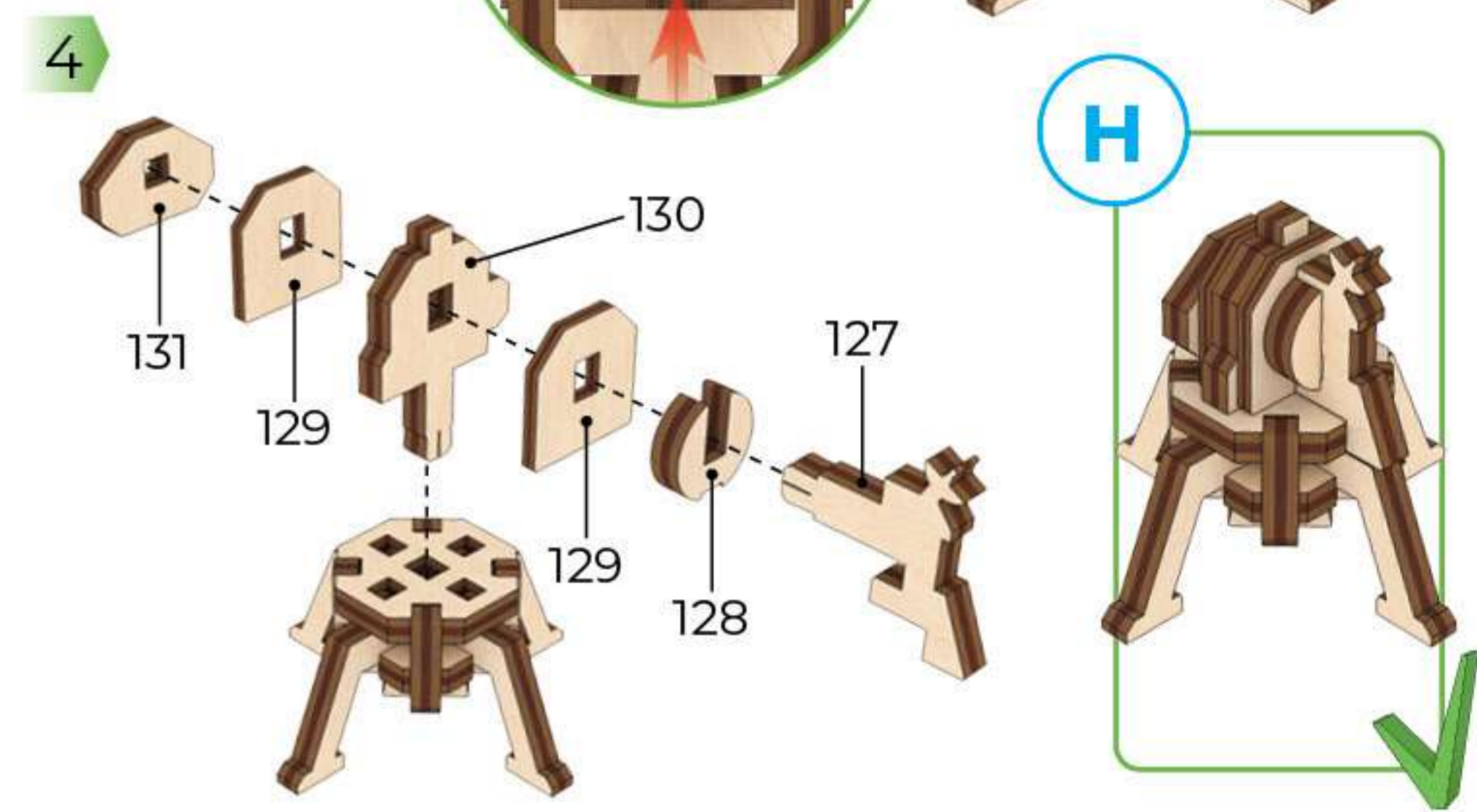
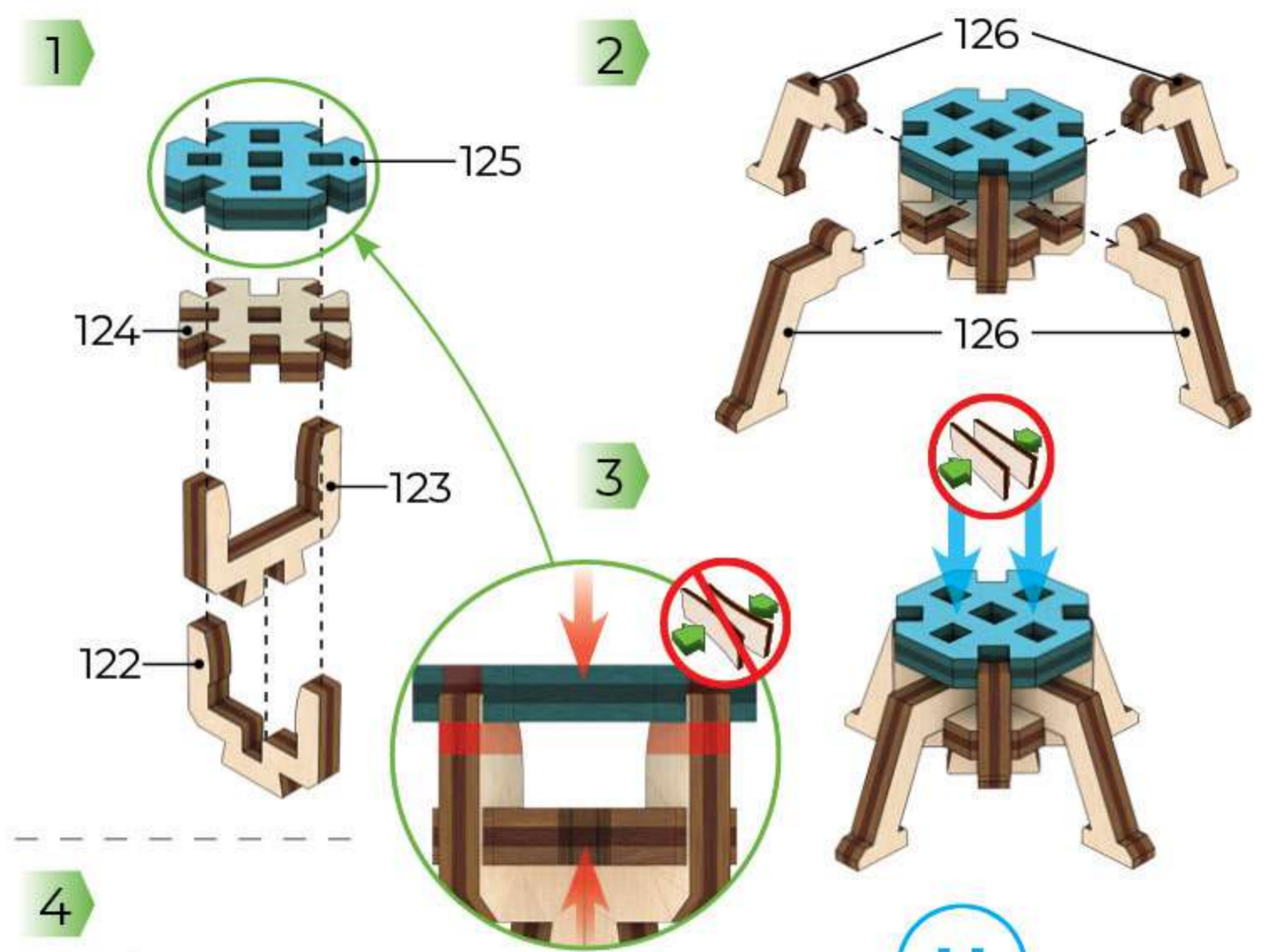
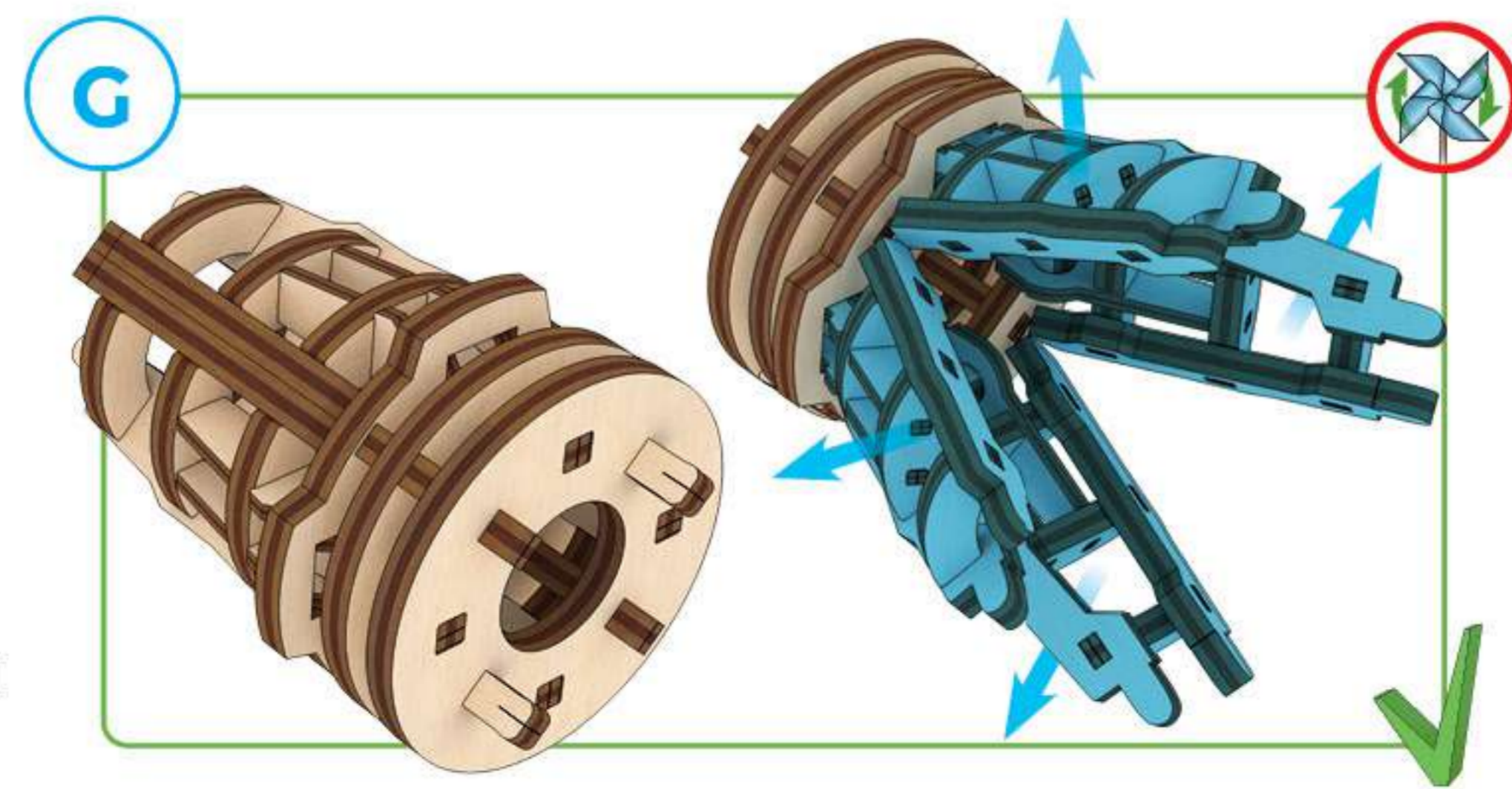
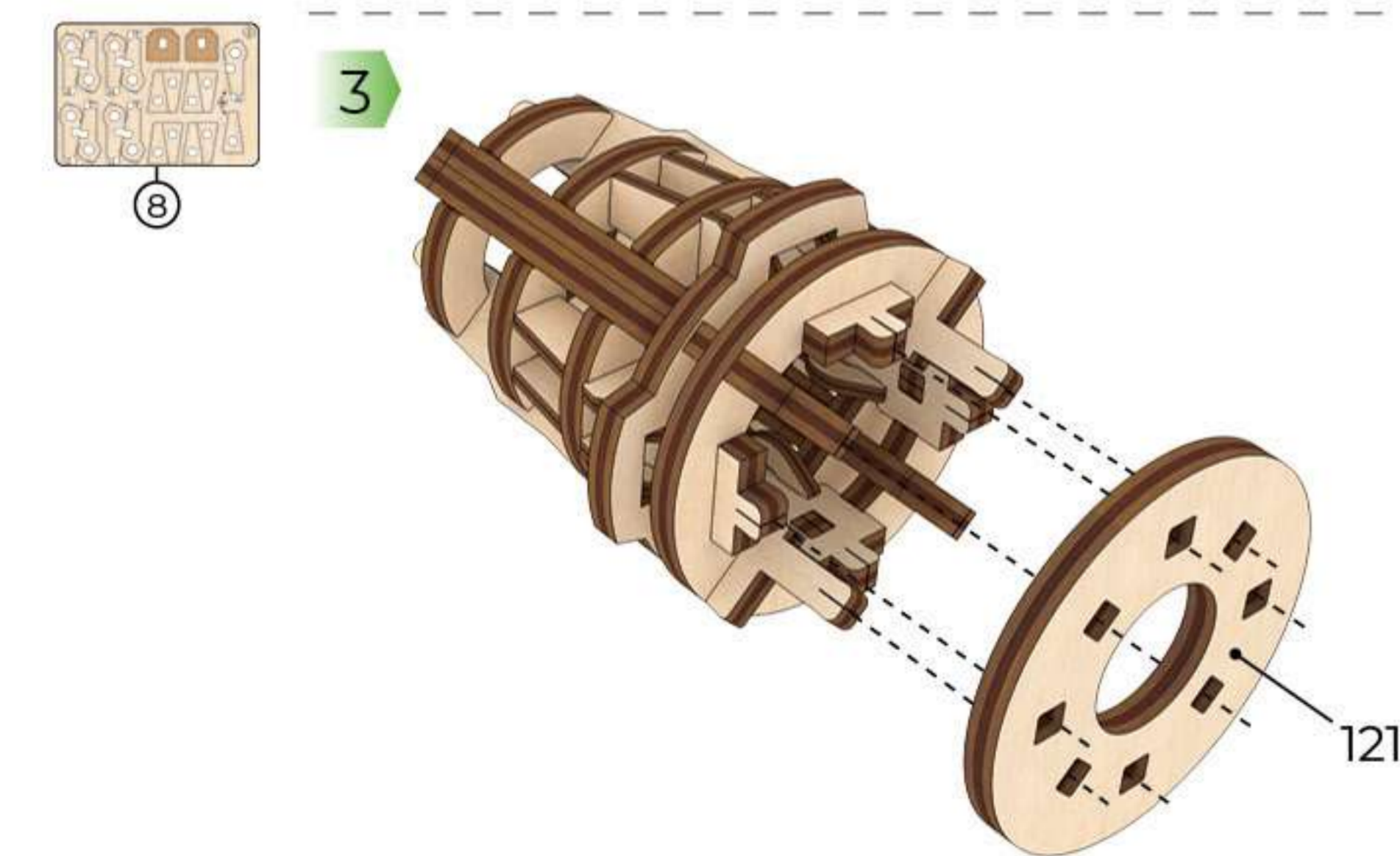
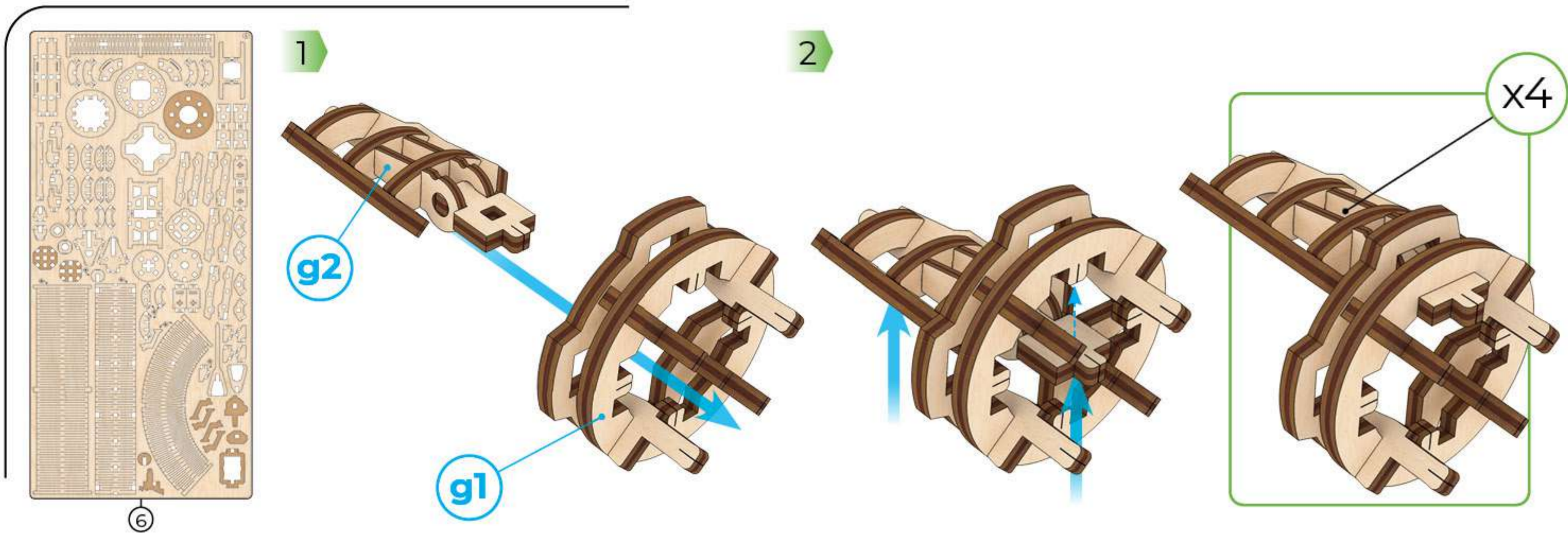

**ENG** The part should be easily rotated (moved). **UKR** Деталь повинна легко крутитися (рухатися). **FRA** La pièce doit tourner (se déplacer) aisément. **DEU** Der Teil soll leicht gedreht (bewegt) werden. **SPA** La pieza debe ser fácil de girar (mover). **ITA** Il componente deve girare (muoversi) facilmente. **JPN** 部品はしつかりと動かなければなりません。 **CHI** 此部件必须容易的旋转 (移动) **POL** Element powinien łatwo się kręcić (poruszać się). **POR** A peça deve ser facilmente girada (movida). **KOR** 활하게 움직일 수 있어야합니다.

1

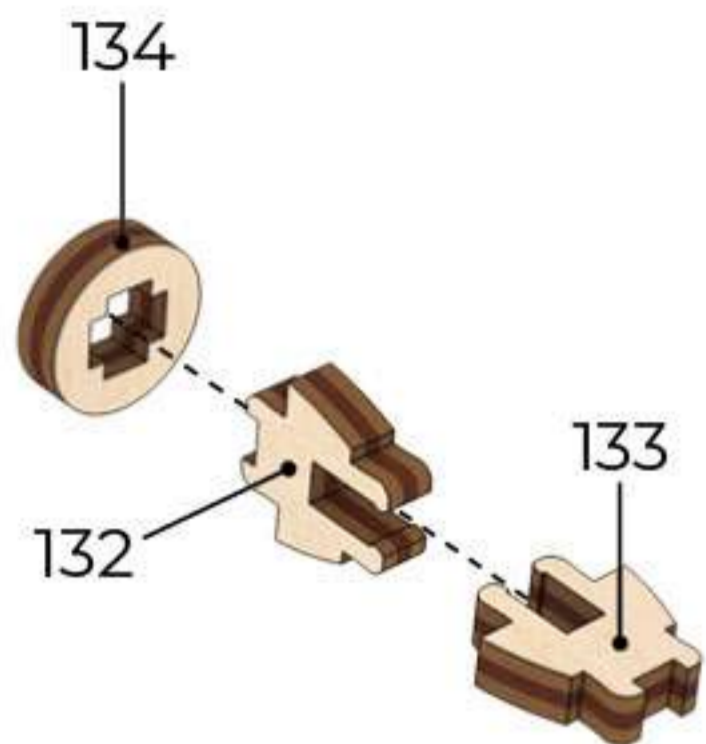

i1



1

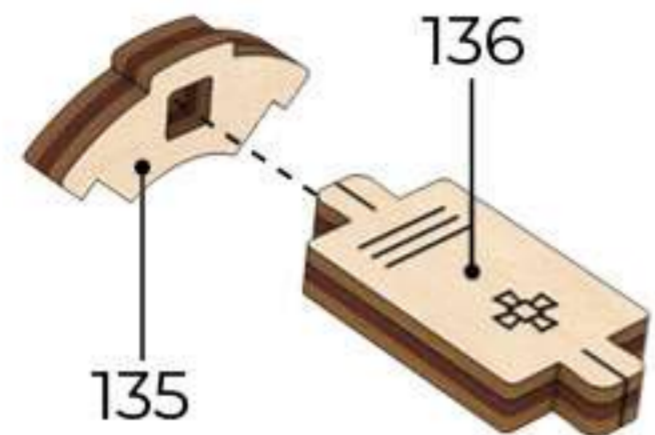

i2



x4

1

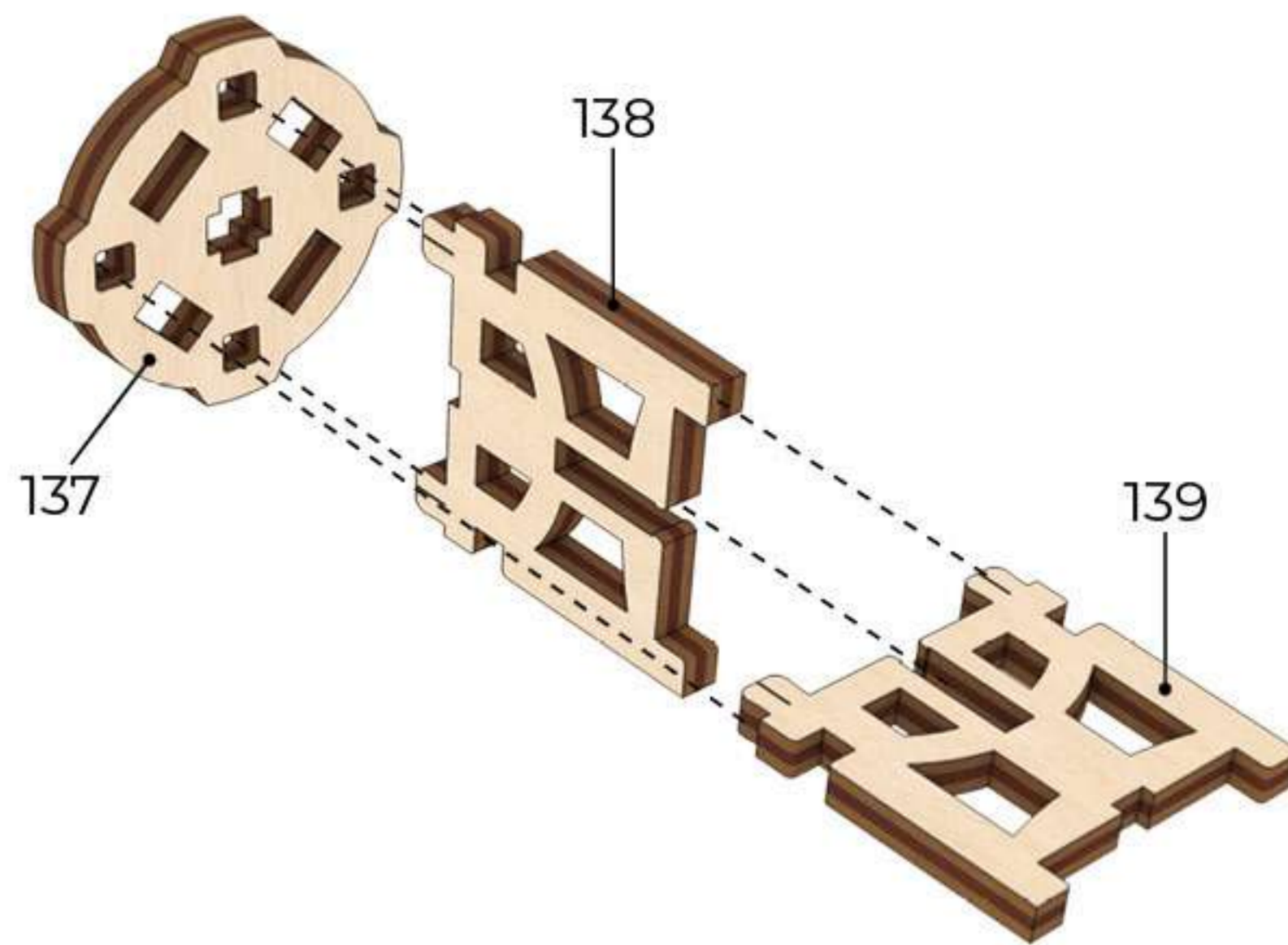

i3

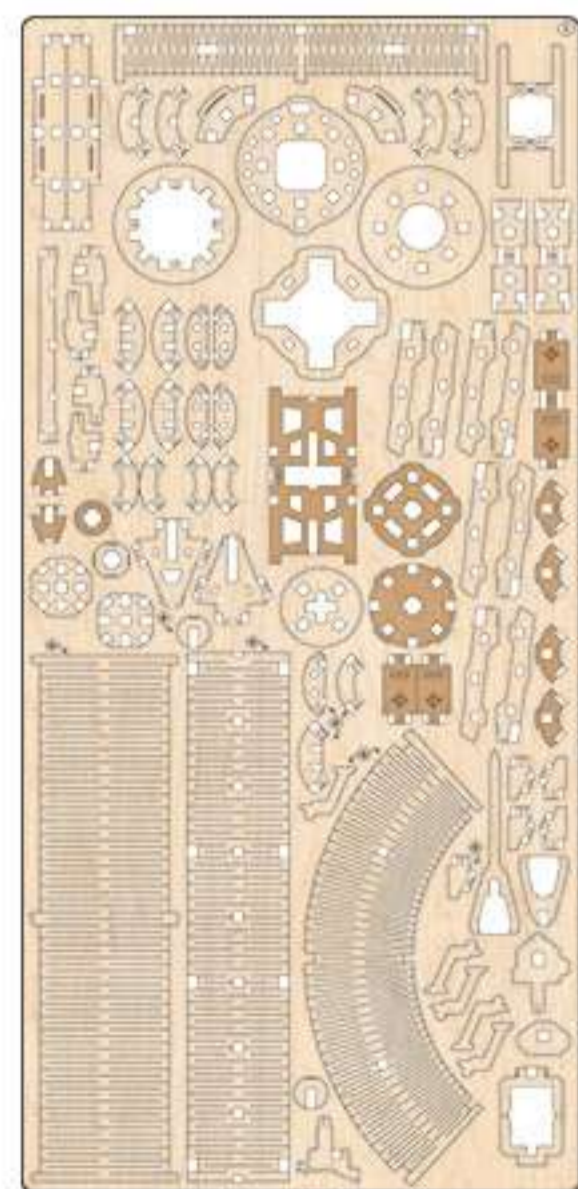
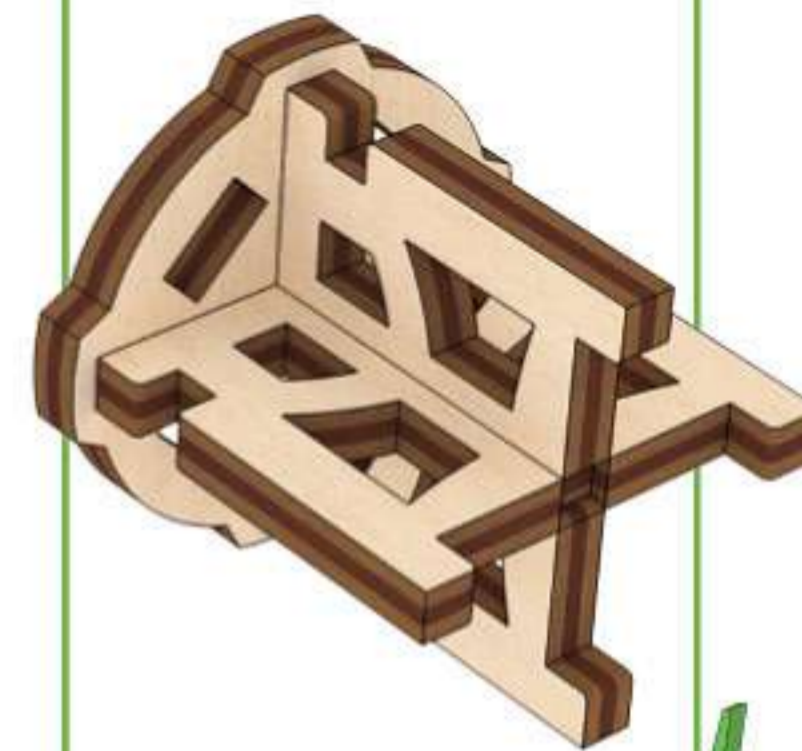

1

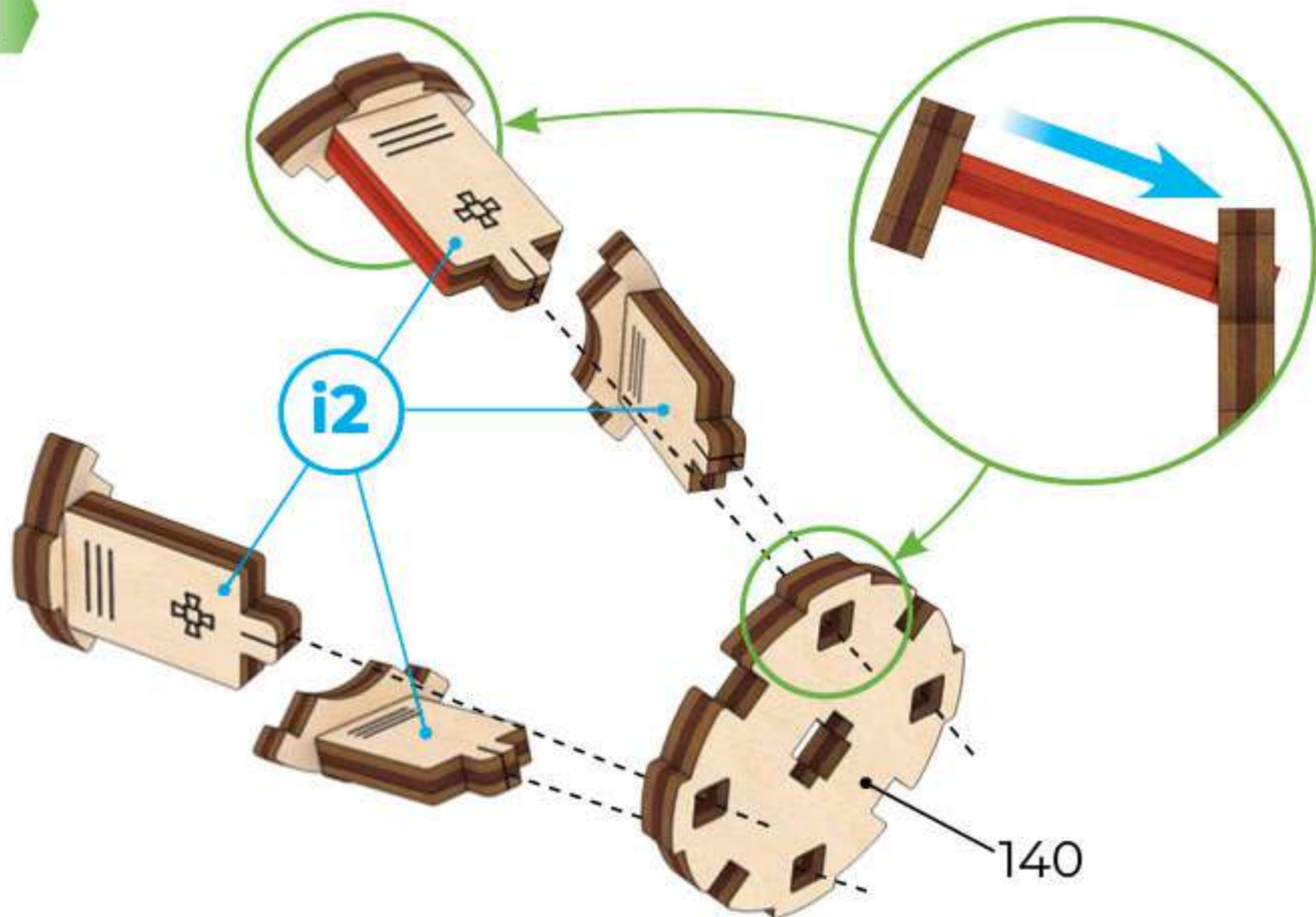

2

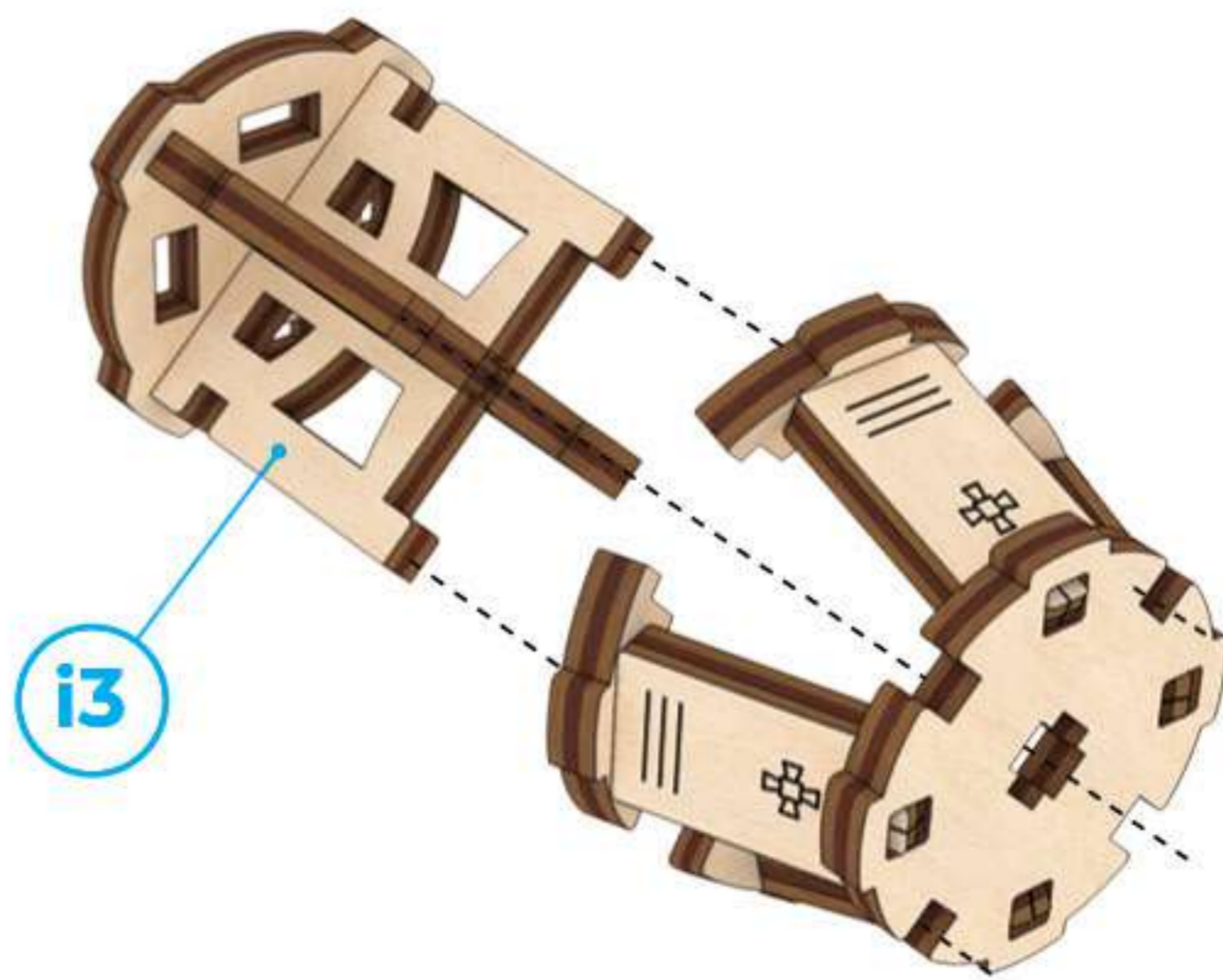

3

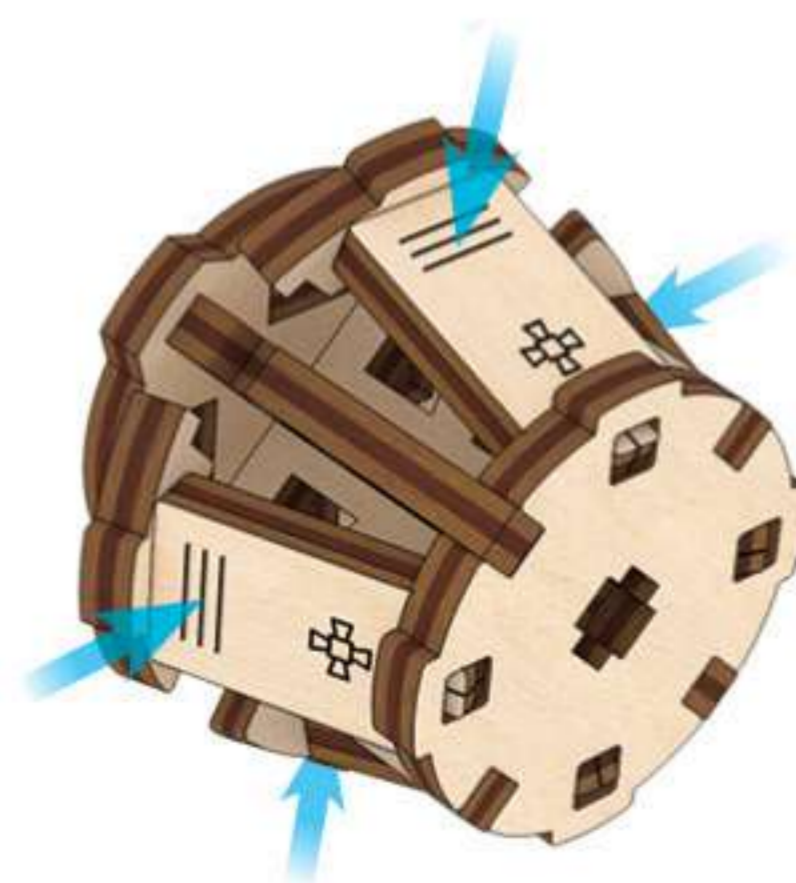

i4

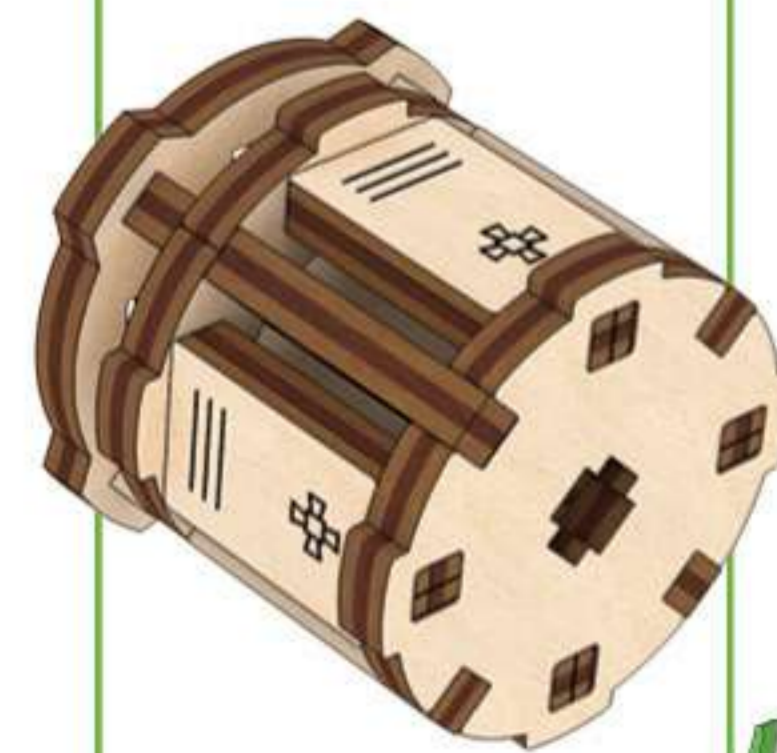



1

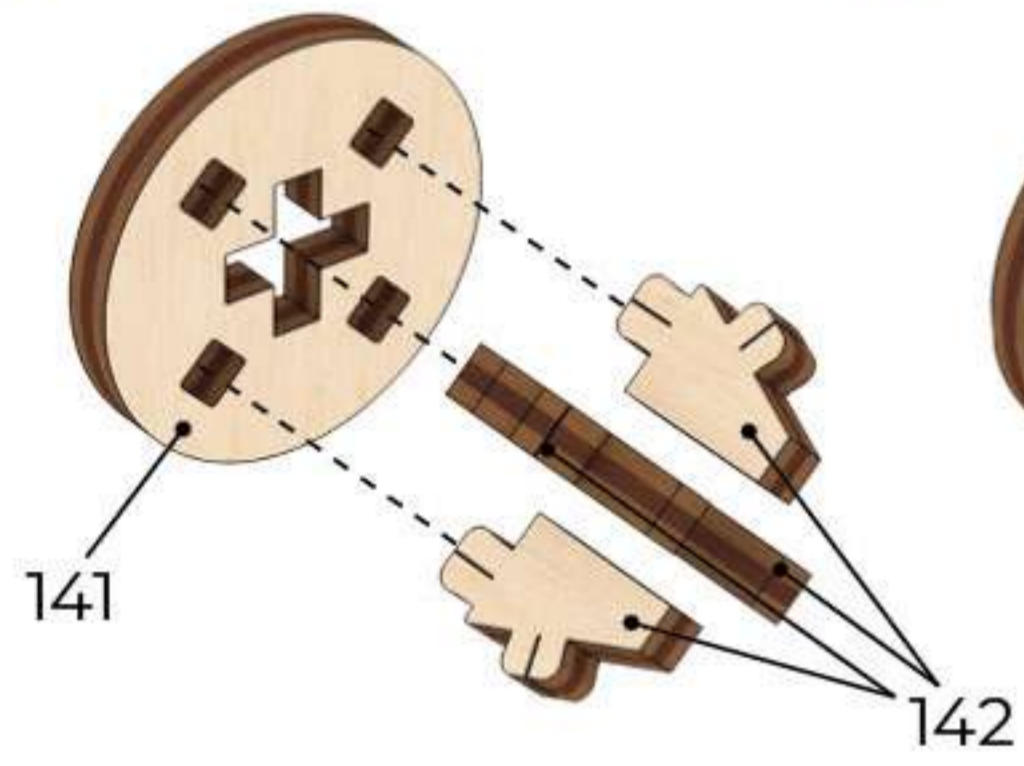

2

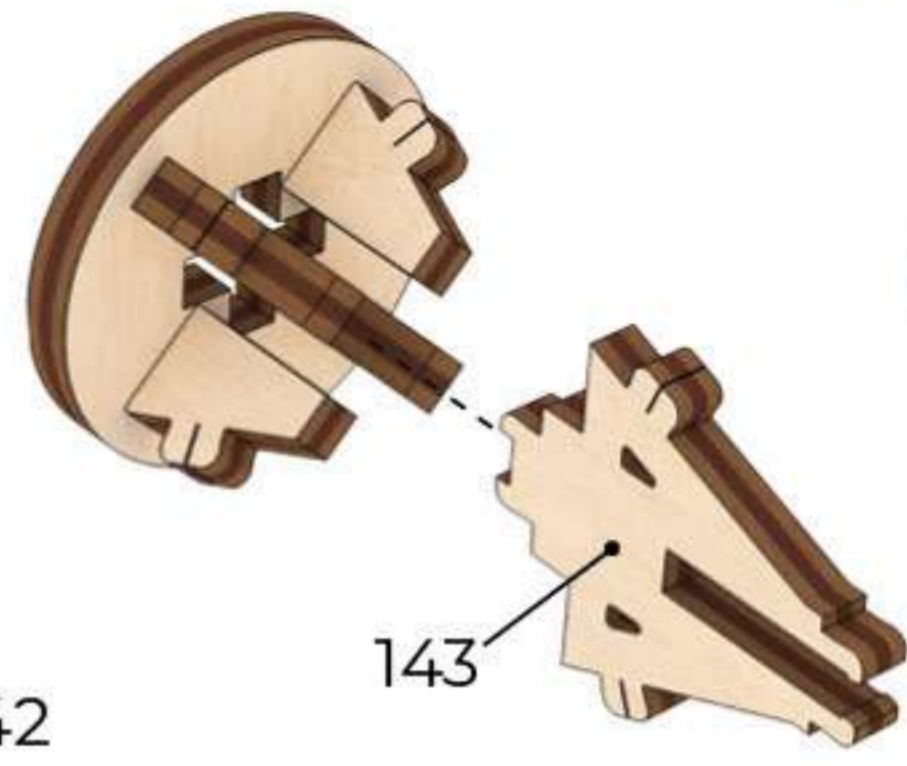

3

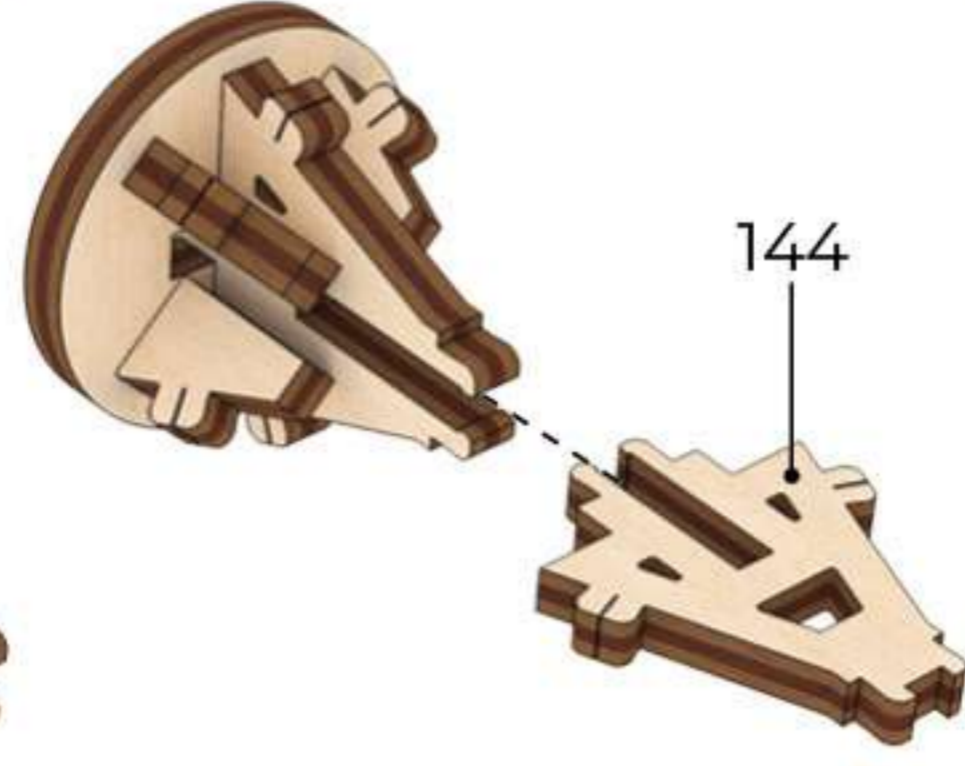

4

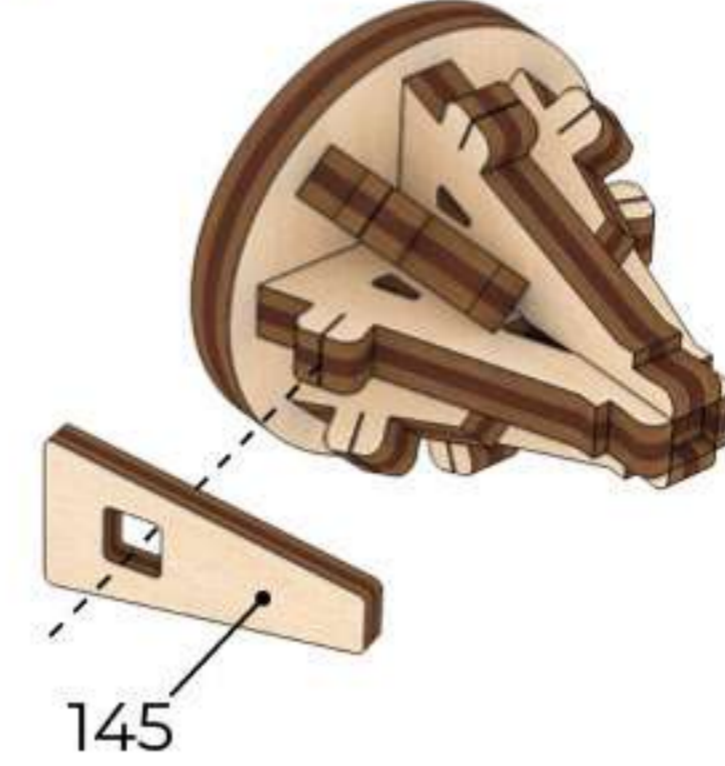

5

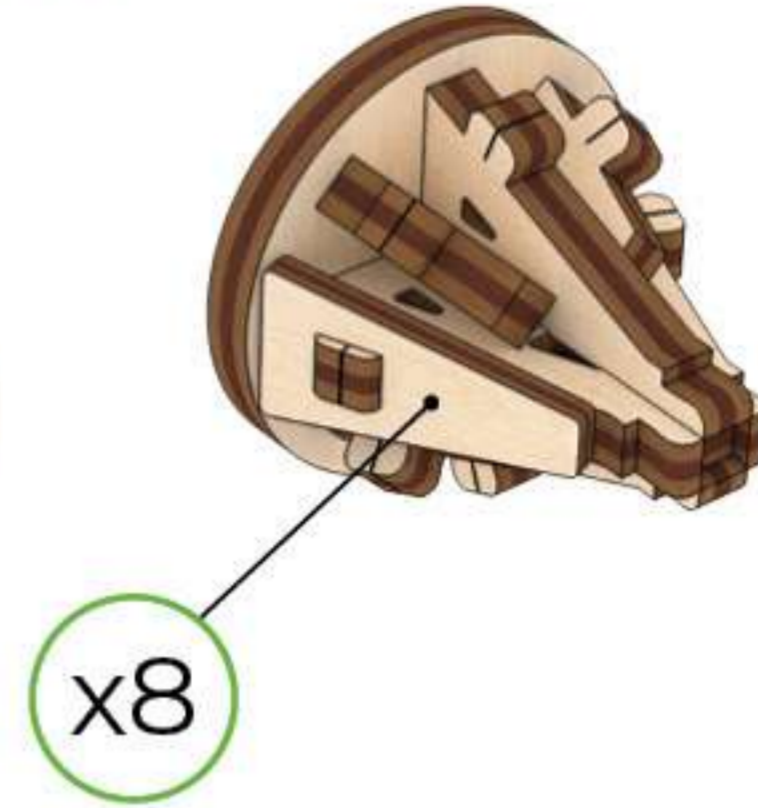

6



7

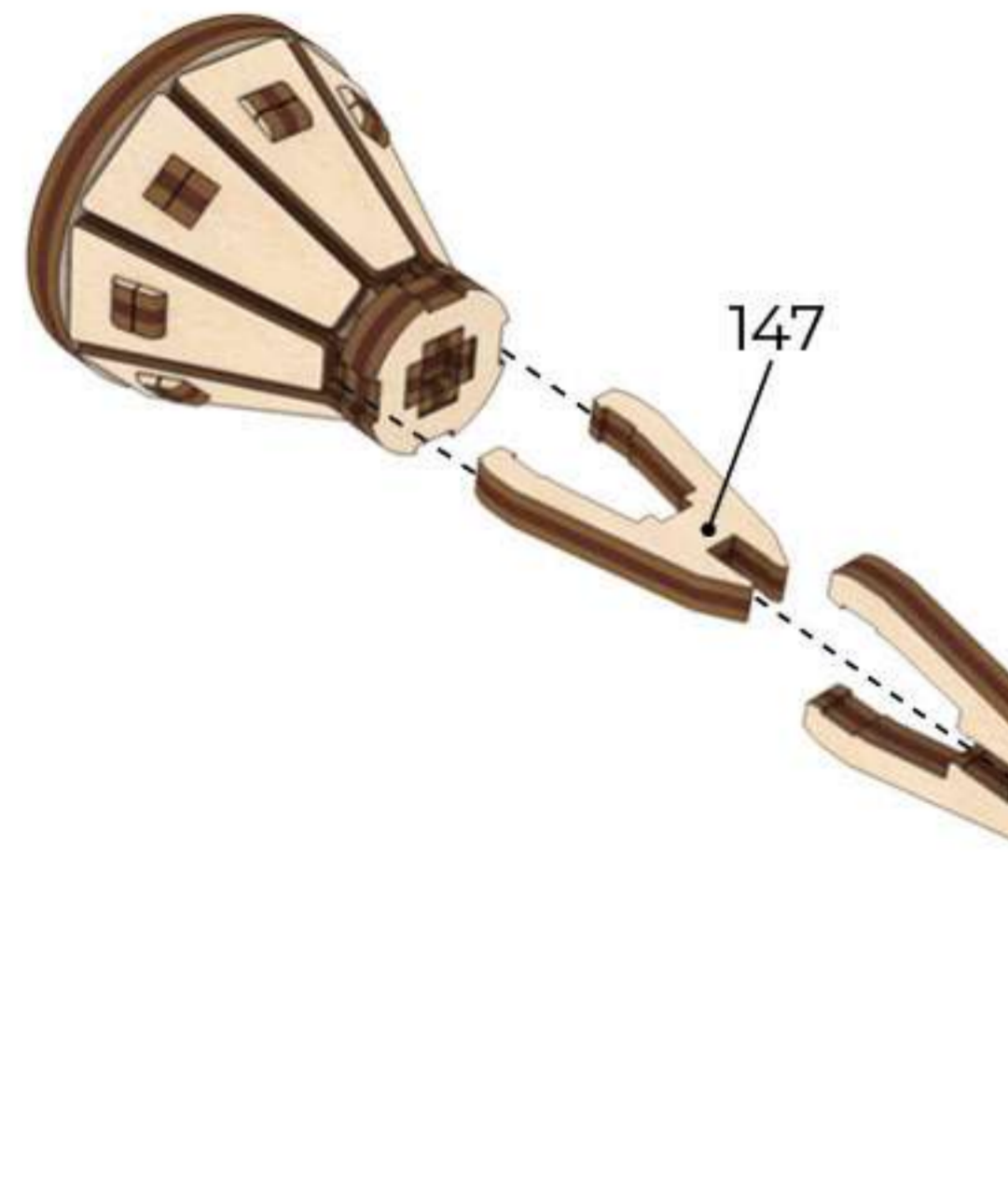

8

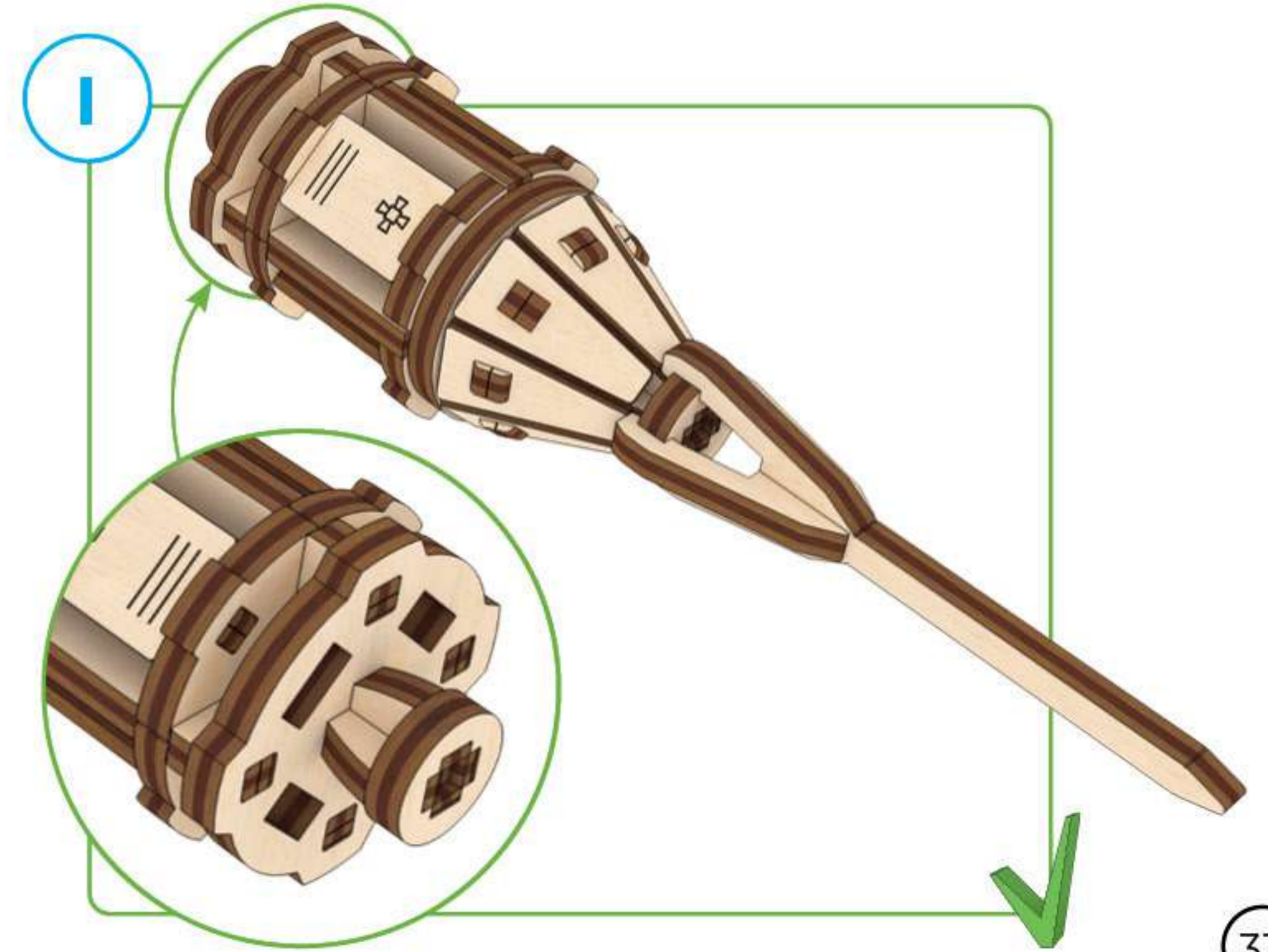
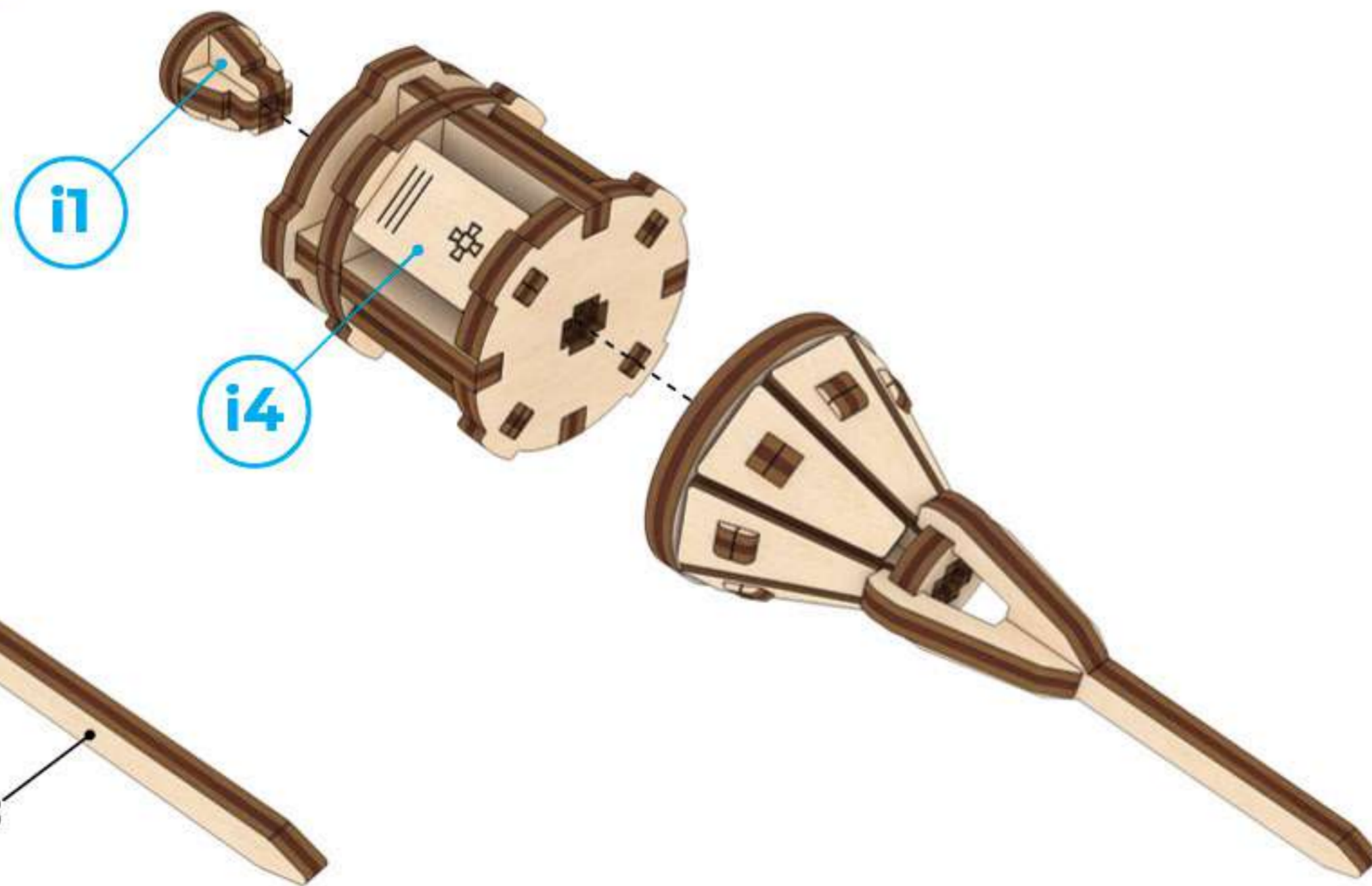

1

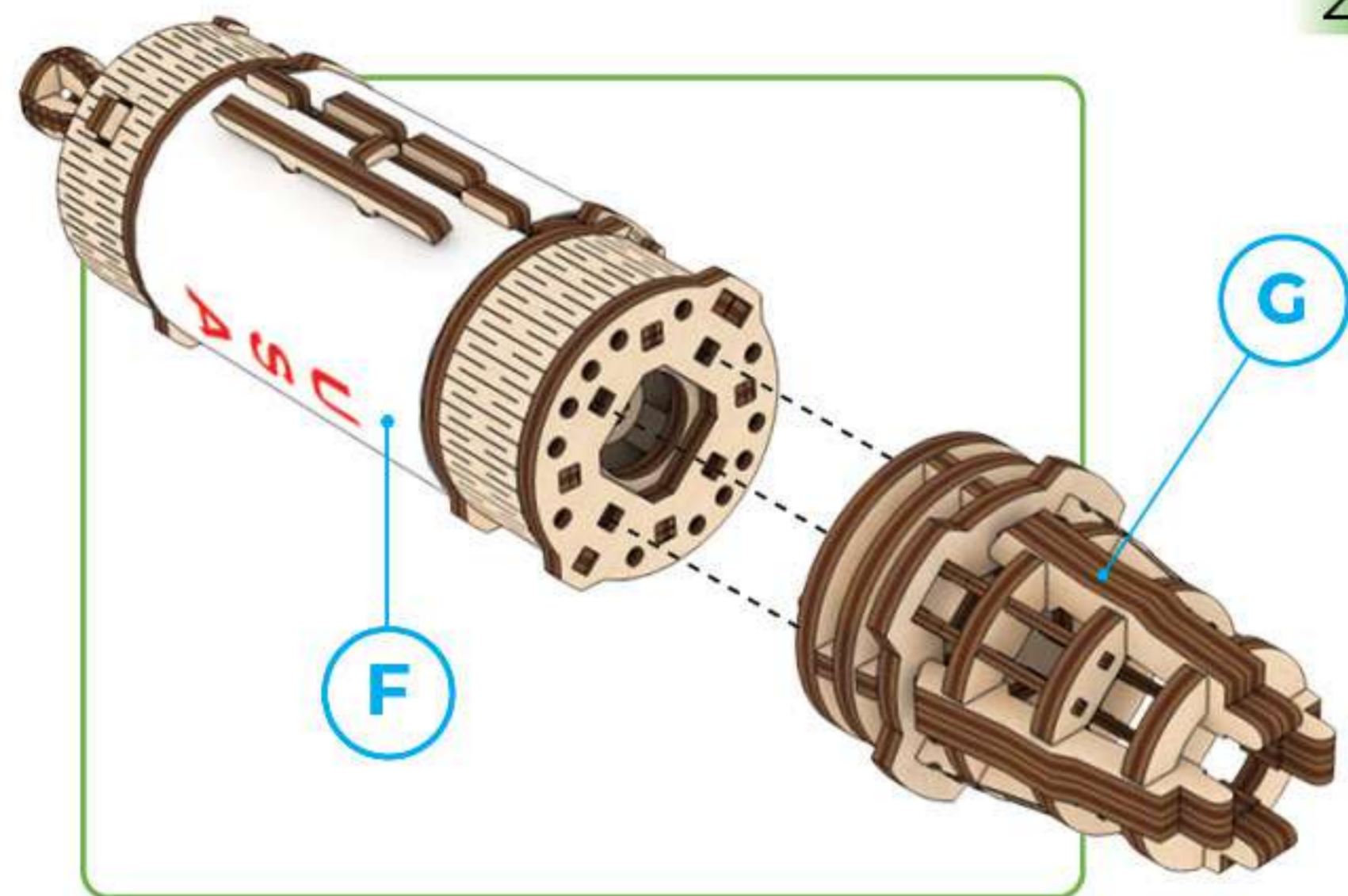

2

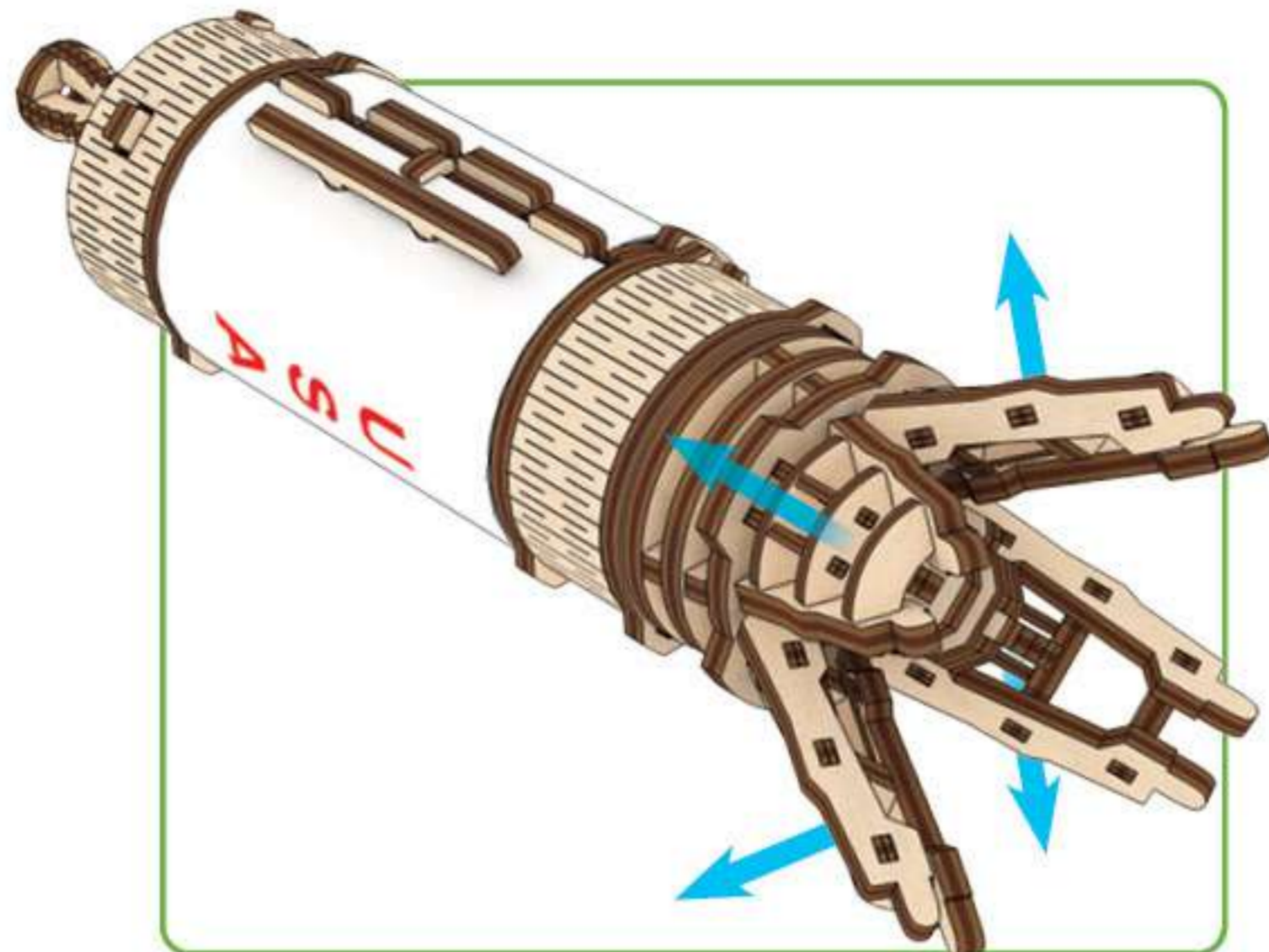

3

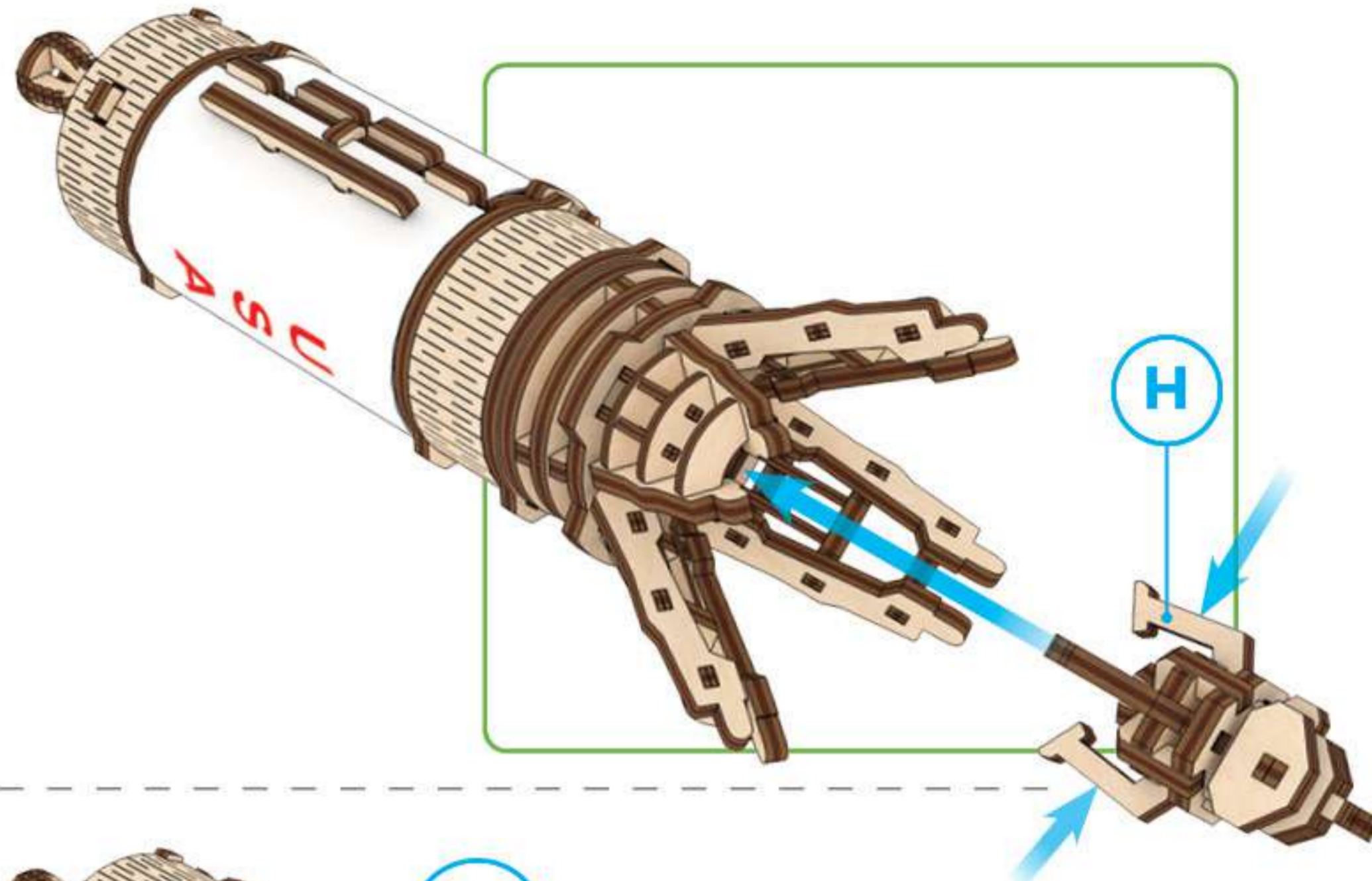

4

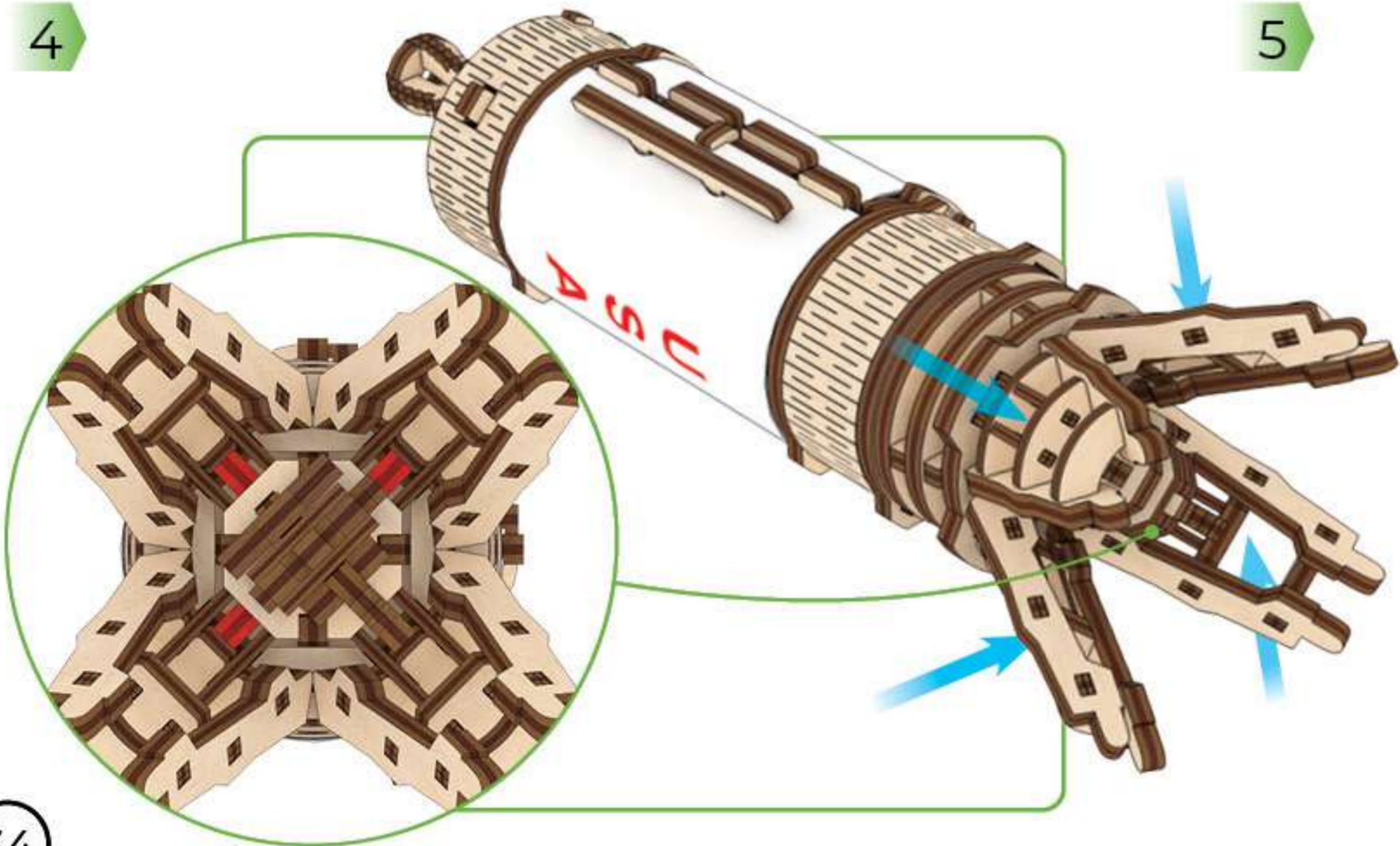

5

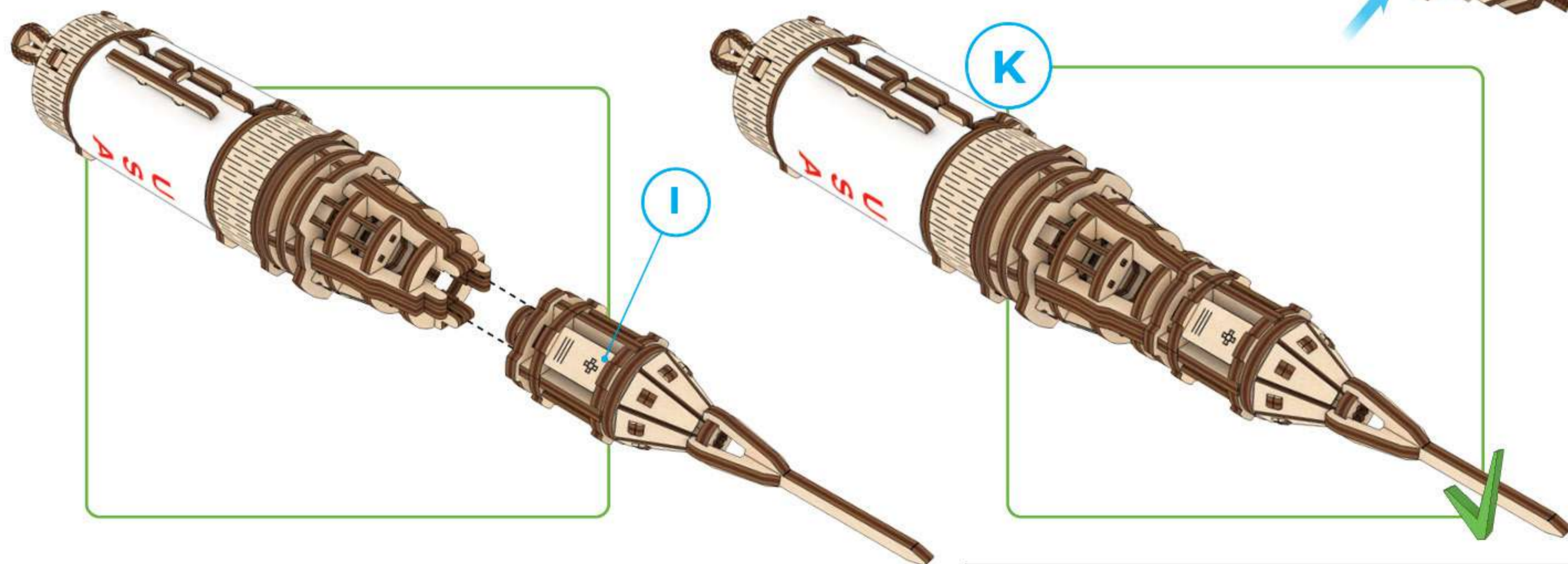

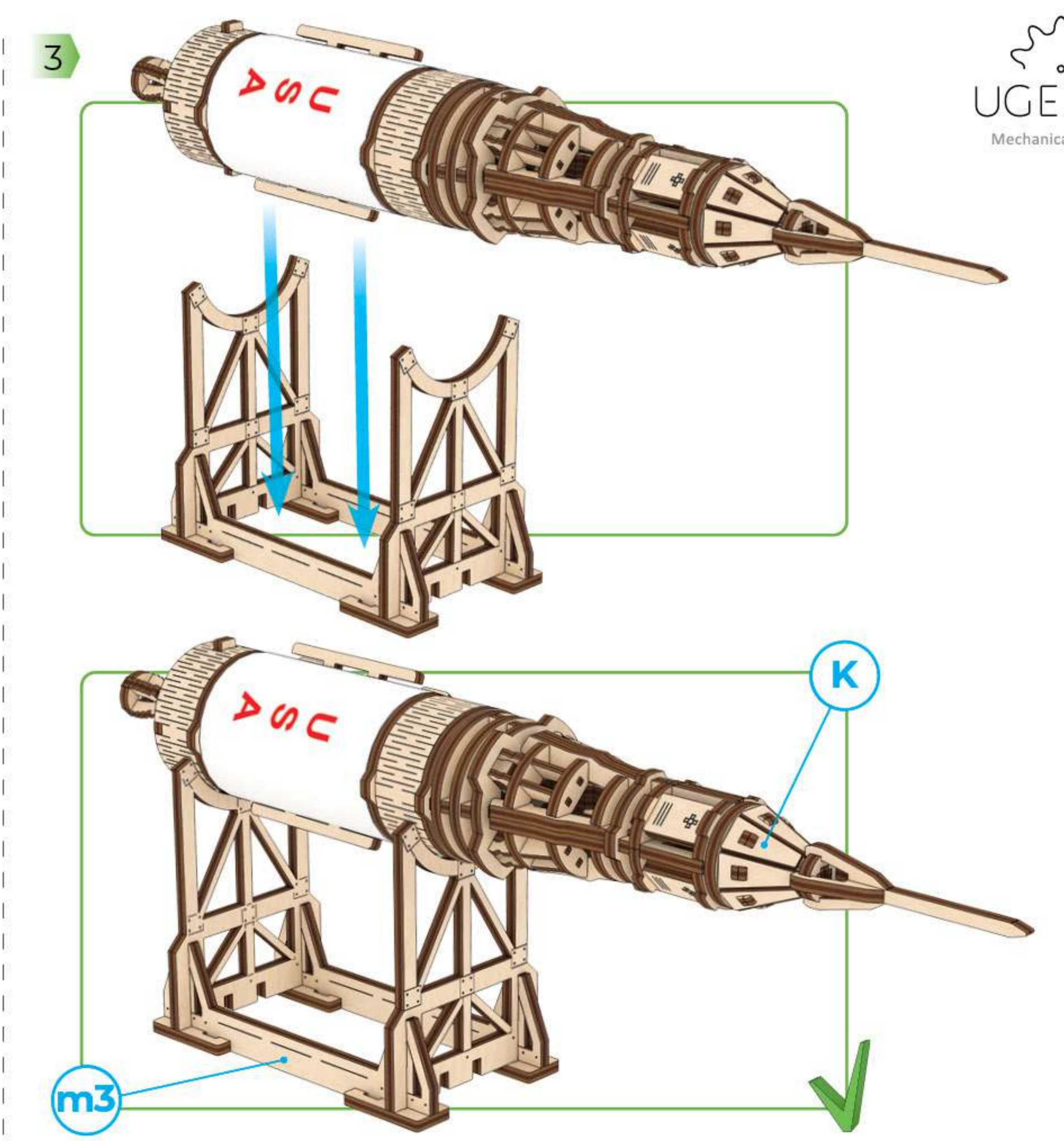
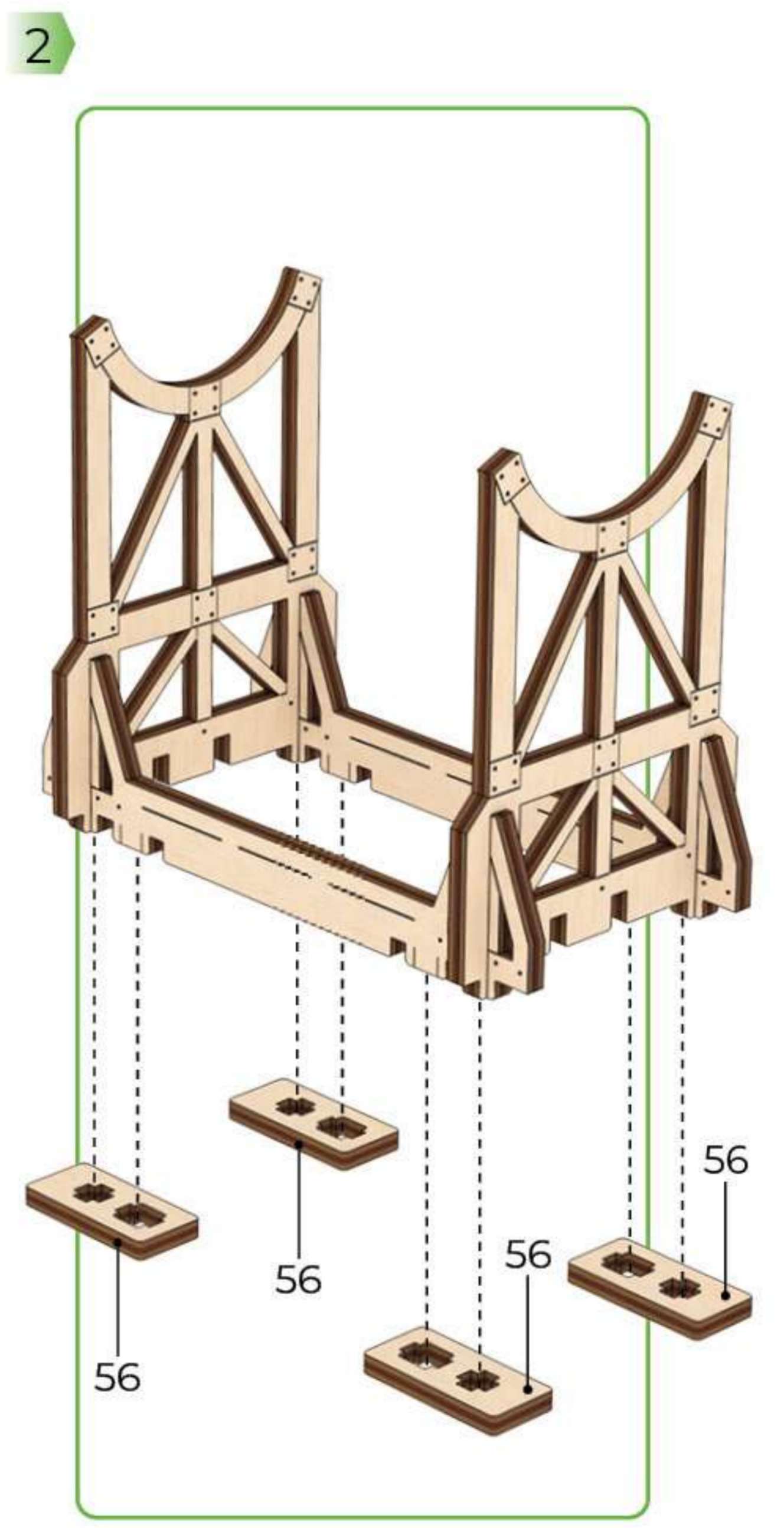
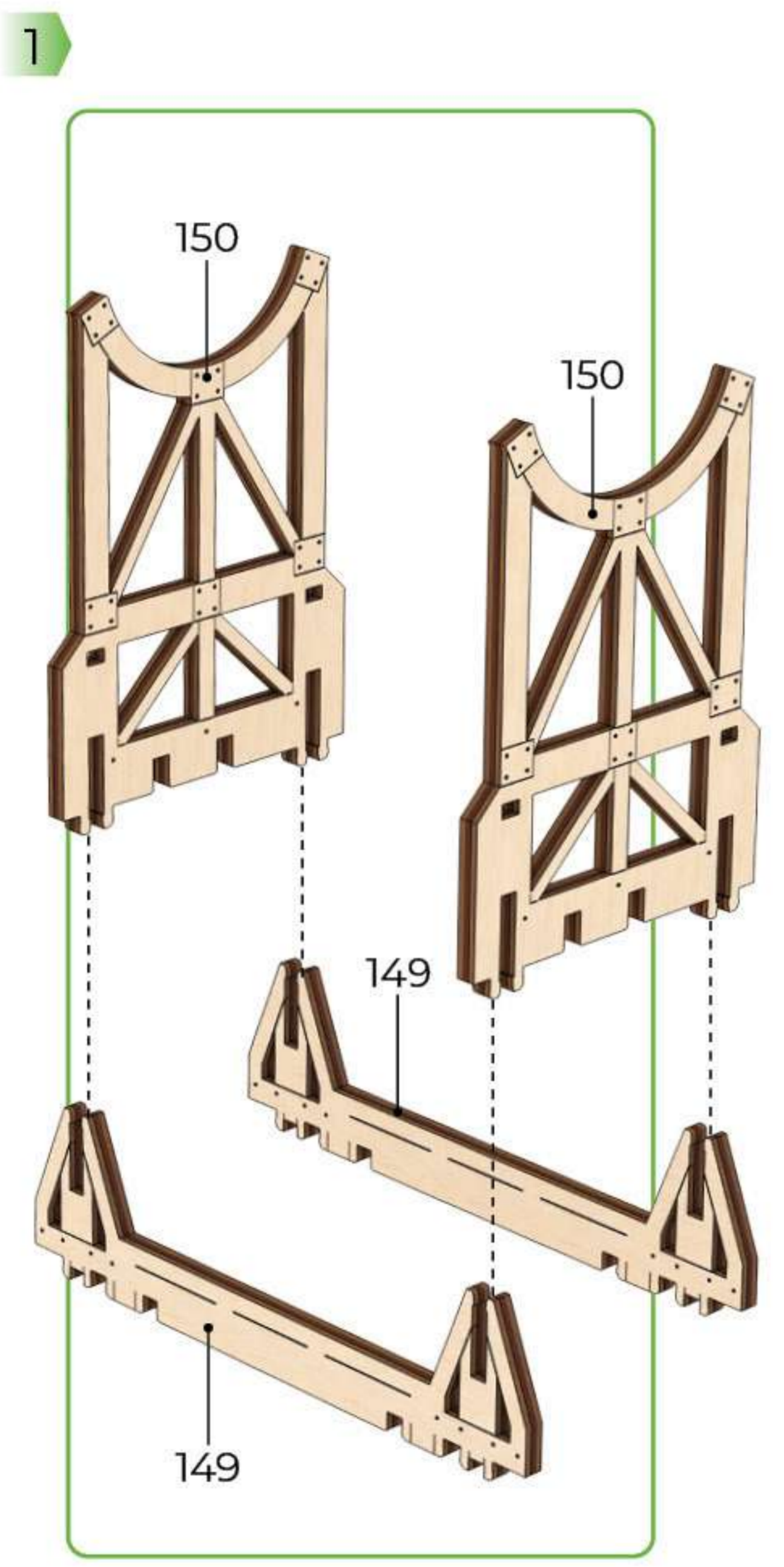
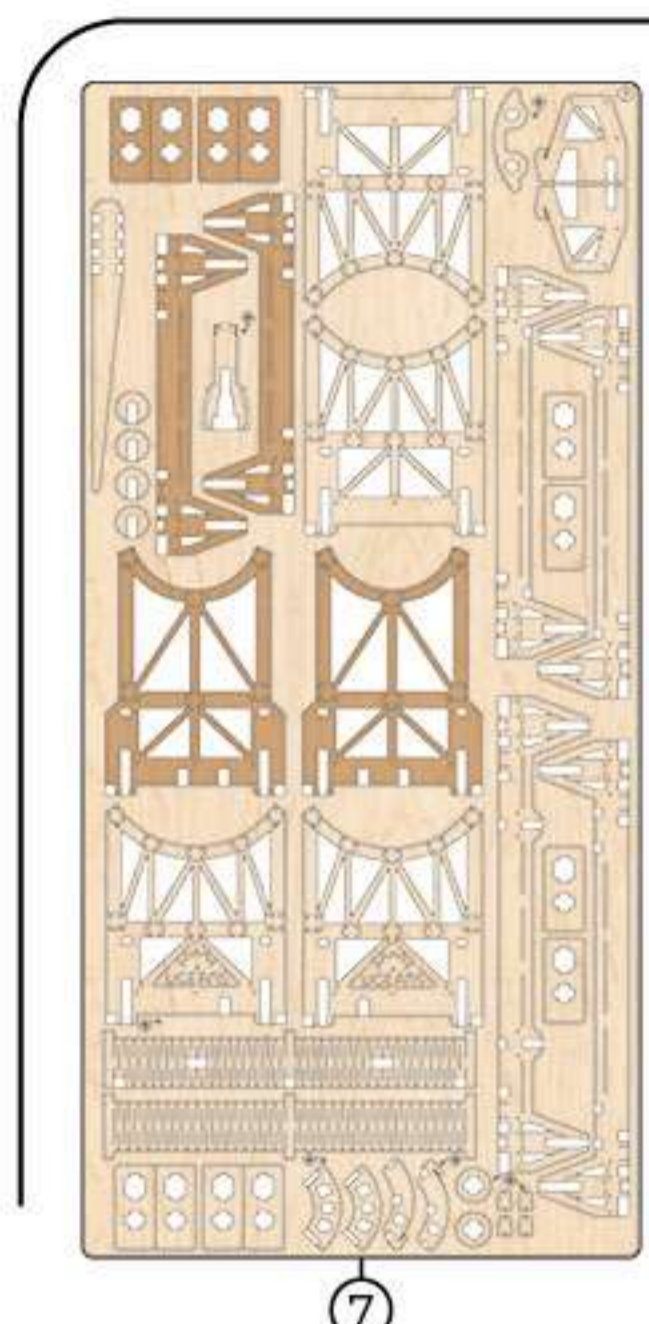

Mechanical models

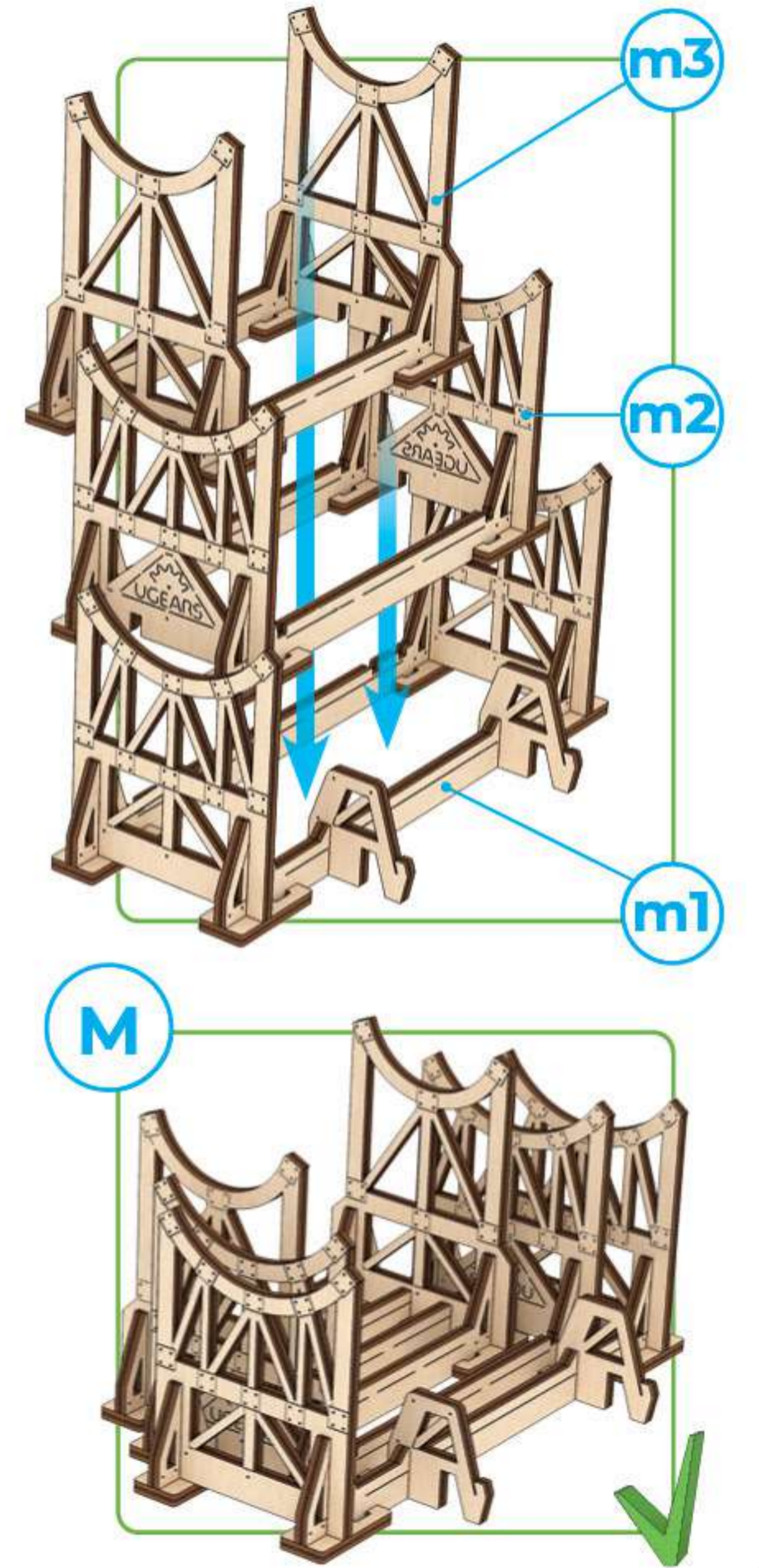
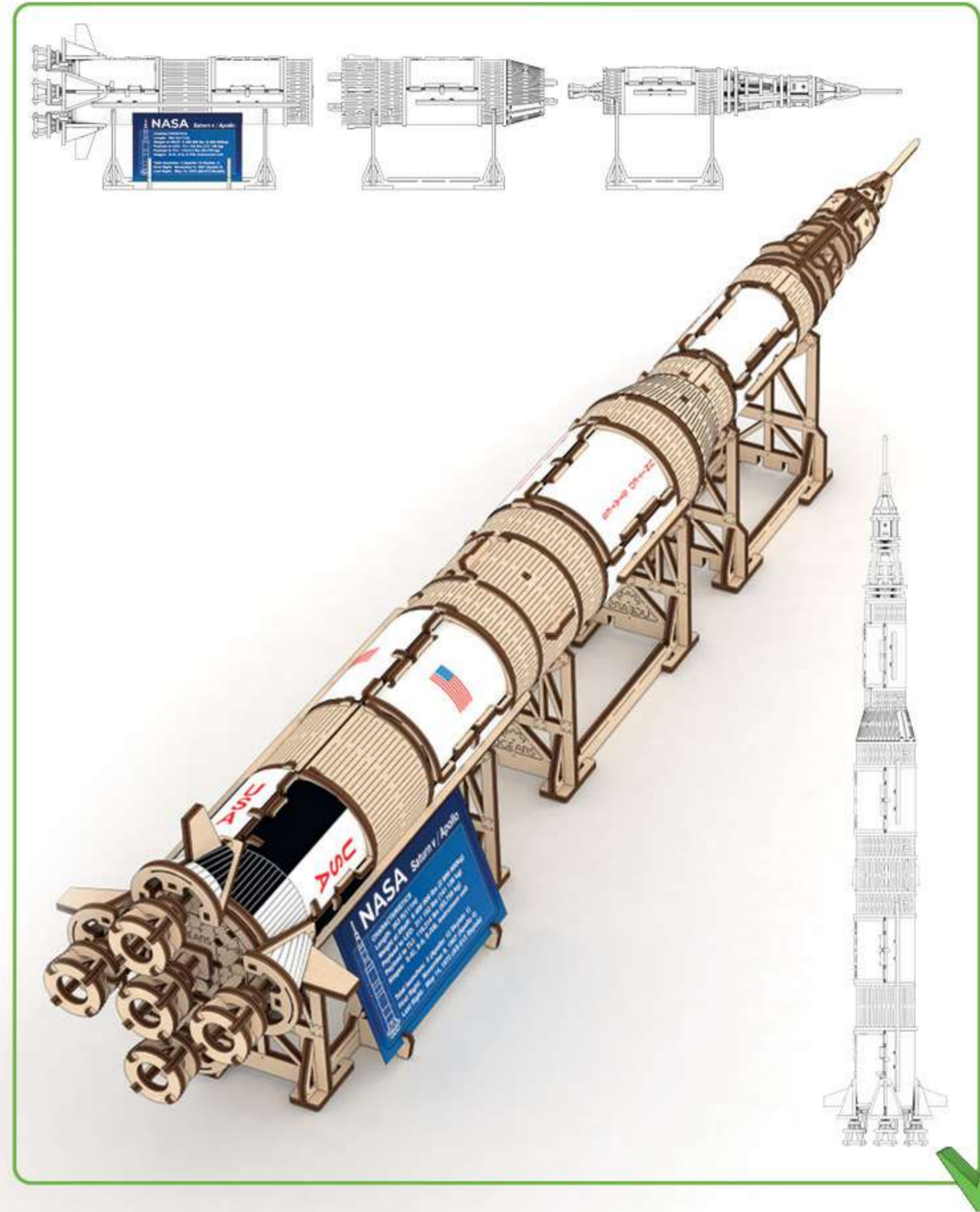
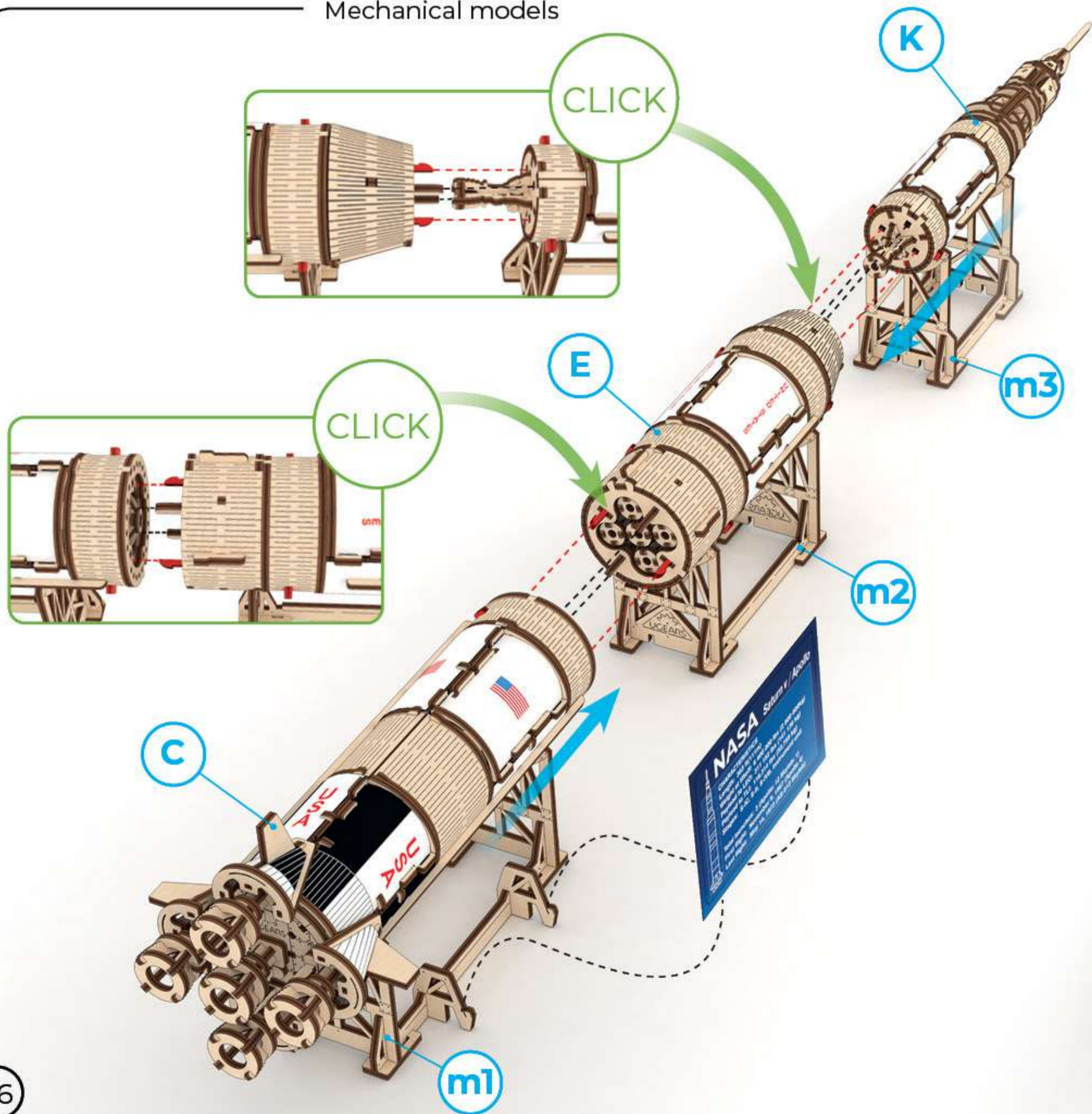

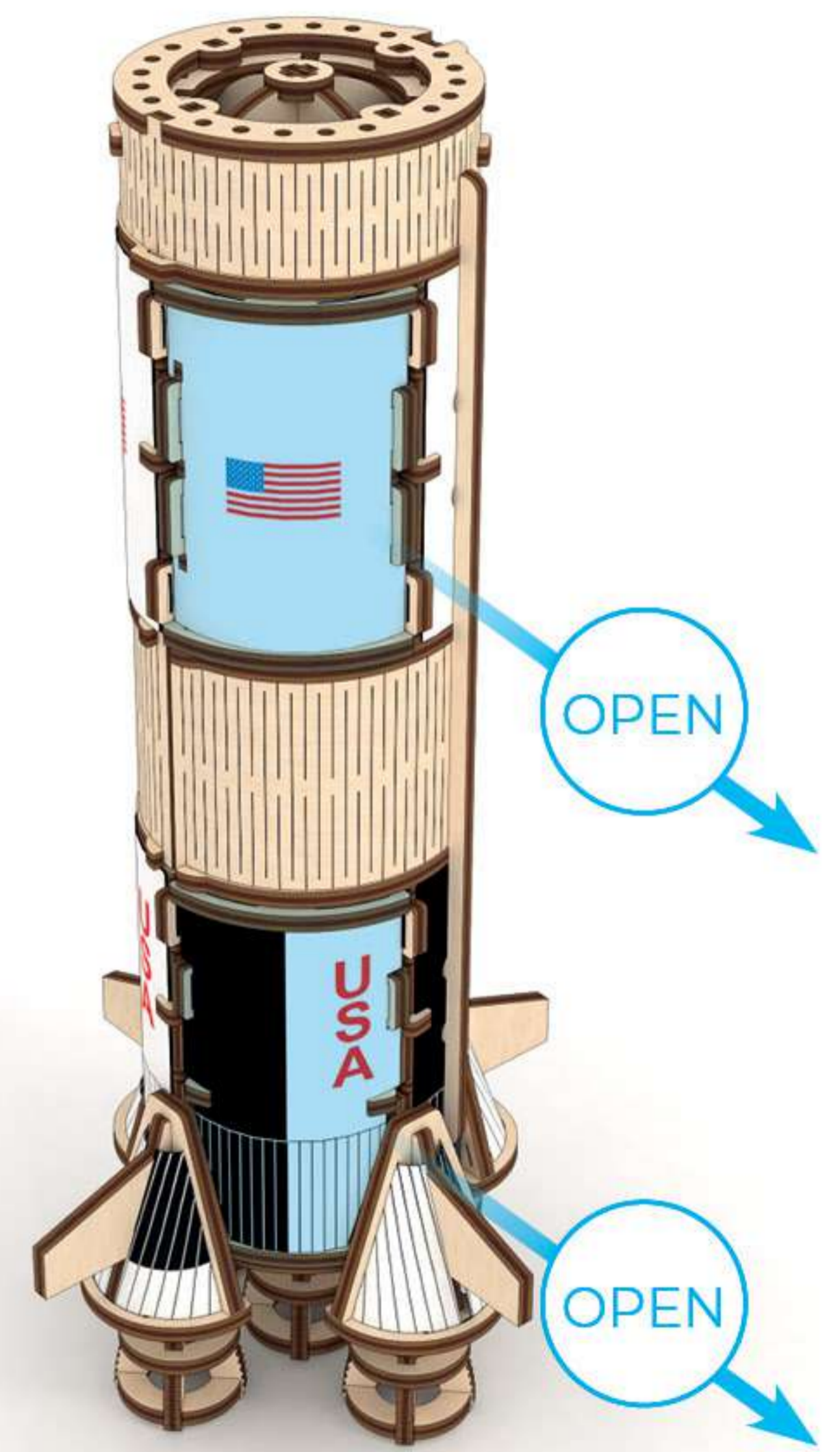
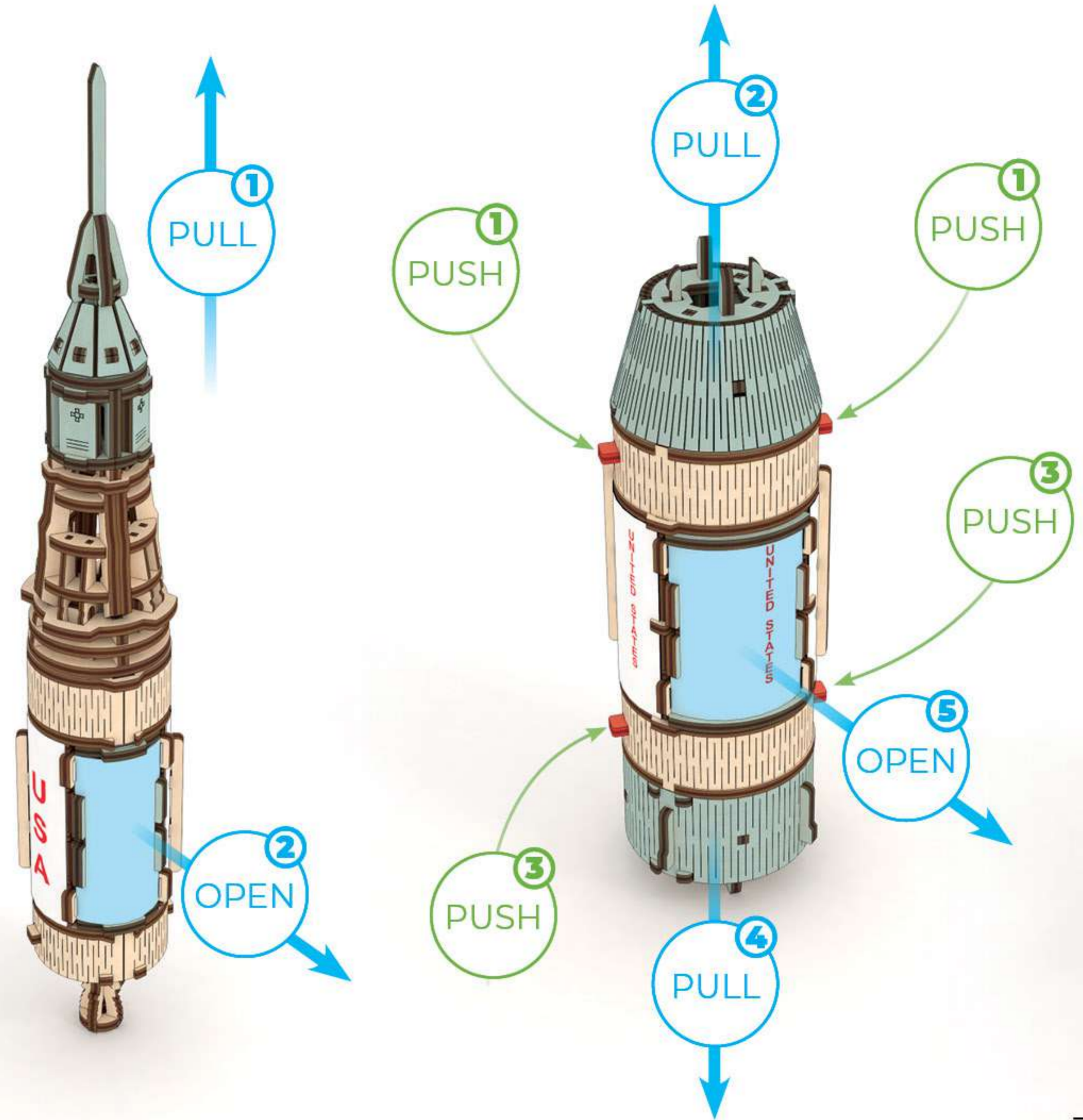
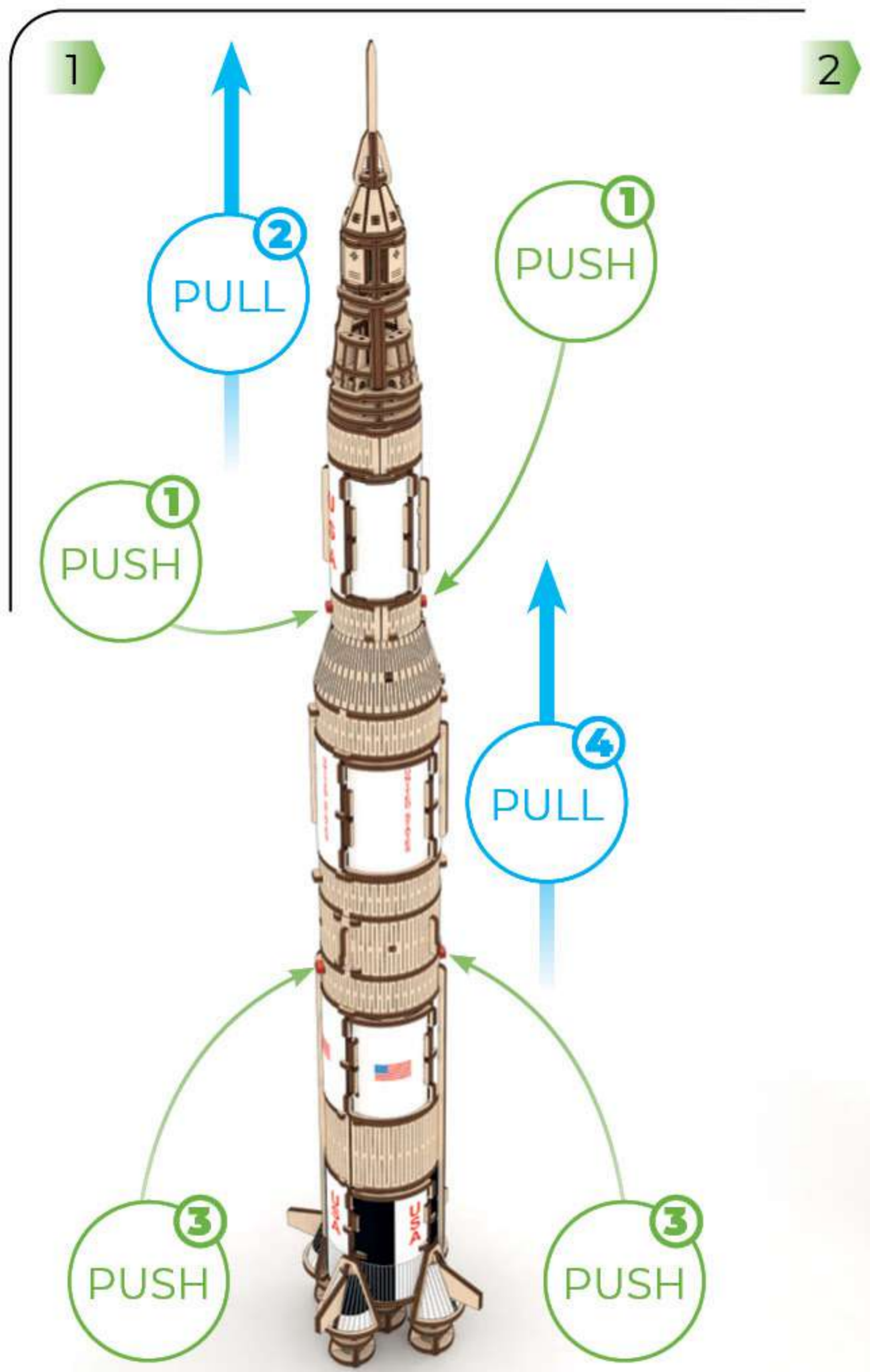

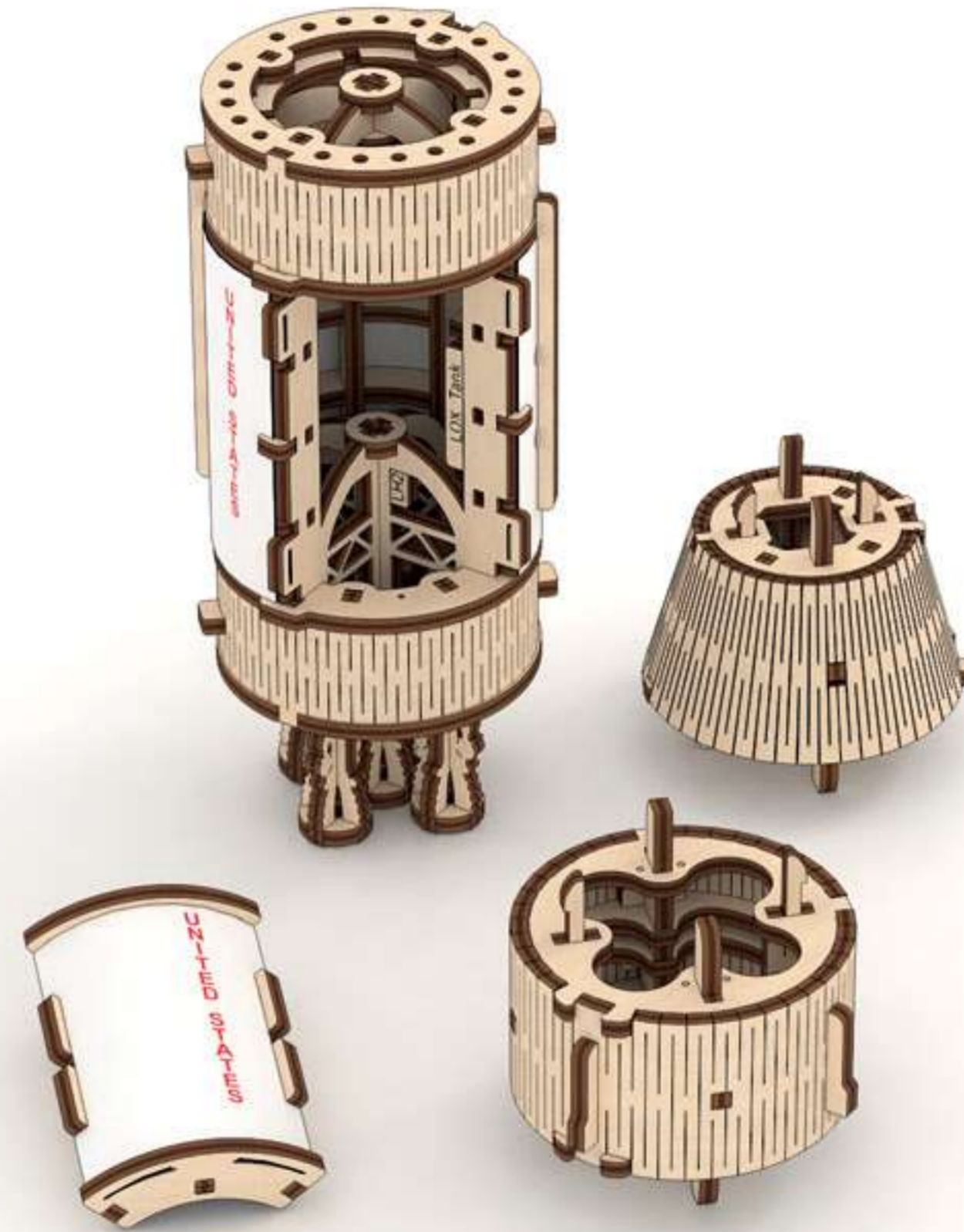

# YOU MAY ALSO LIKE

## NASA Lunar Rover



319 PARTS

8 HOURS ASSEMBLY TIME

ADVANCED LEVEL



## Manned Mars Rover

Explore the Red Planet with me!



562 PARTS

8 HOURS ASSEMBLY TIME

ADVANCED LEVEL



## NASA Space Shuttle Discovery



315 PARTS

6 HOURS ASSEMBLY TIME

ADVANCED LEVEL



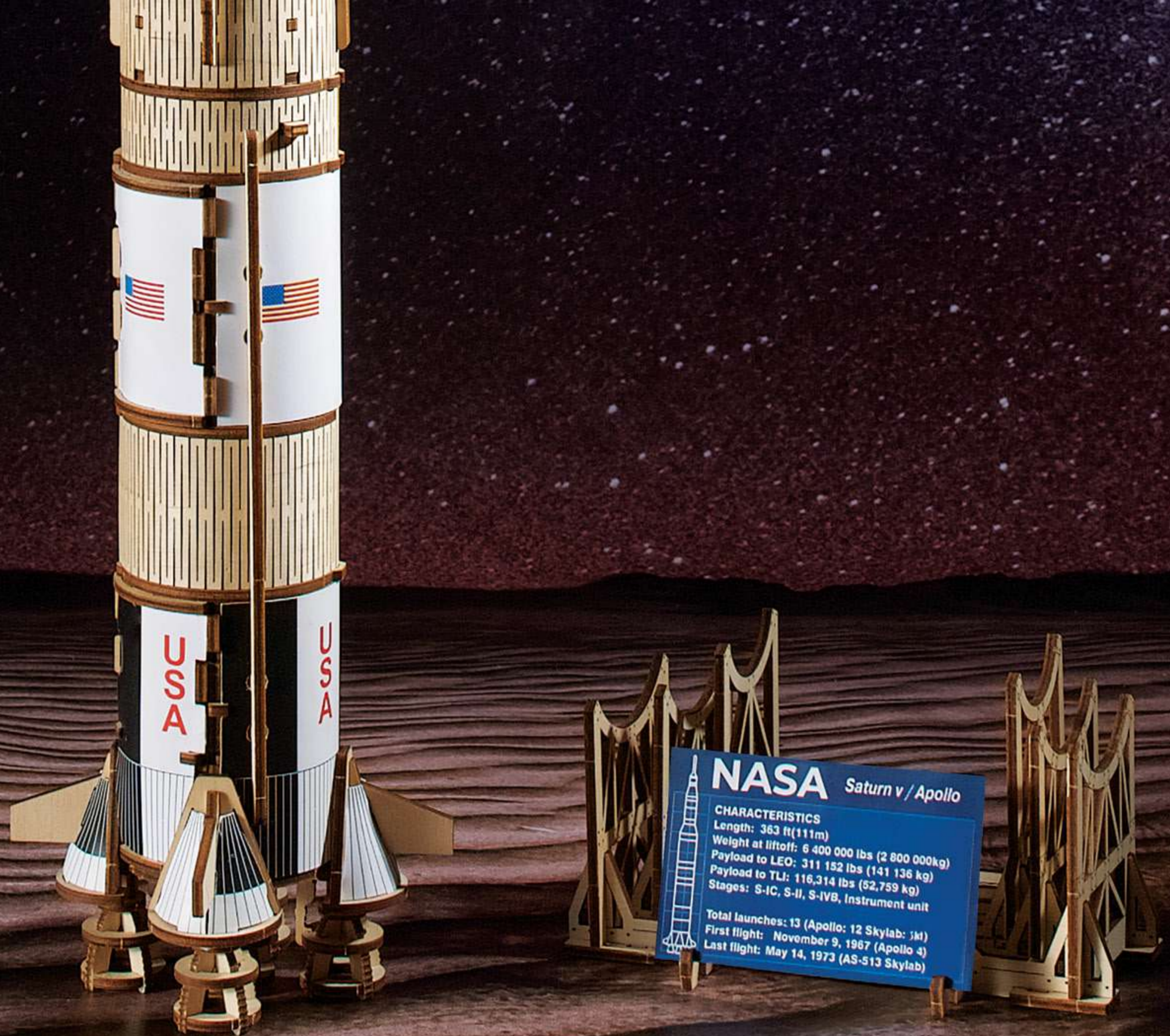

Watch the VIDEO

# UGEARS

Mechanical models

**ENG** Thanks for following along on this journey with us.

**UKR** Дякуємо, що ви пройшли цей шлях з нами.

**FRA** Merci denous avoir accompagnés tout au long de ces étapes.

**DEU** Vielen Dank, dass Sie diesen Weg mit uns gegangen sind.

**SPA** Gracias por haber recorrido el camino con nosotros.

**ITA** Grazie per aver fatto uesto percorso con noi.

**JPN** UGEARSをご利用いただきありがとうございます

**CHI** 感谢您参与有趣的模型拼装过程。

**POR** Obrigado por seguir nesta jornada conosco.

**POL** Dziękujemy, że razem z nami pokonałeś tę drogę!

**KOR** UGEARS 와 함께해 주셔서 감사합니다.

[ugearsmodels.com](http://ugearsmodels.com)

**ENG** Customer support **UKR** Служба підтримки

**FRA** Service client **DEU** Kundendienst

**SPA** Servicio al cliente **ITA** Servizio di supporto

**JPN** お客様窓口 **CHI** 客户支持 **POR** Atendimento ao cliente

**POL** Wsparcie klienta **KOR** 고객지원

[customerservice@ugearsmodels.com](mailto:customerservice@ugearsmodels.com)



FR  
DONNEZ  
OU  
RECYCLEZ



ASSOCIATION



MAGASIN



LIVRAISON



DÉCHÈTERIE

Adresses sur [quefairedemesdechets.fr](http://quefairedemesdechets.fr)