

# BLK BOX

## WALL MOUNTED PULL UP BAR

21-0225-0C-SK

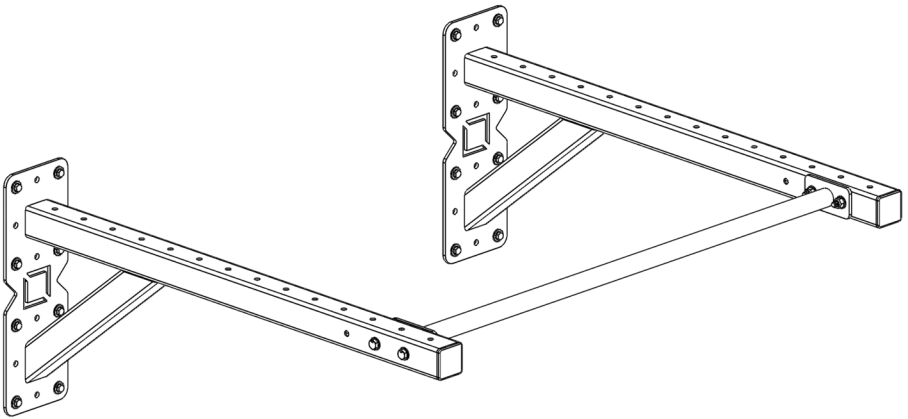

### OWNERS MANUAL & QUICK START GUIDE

NOTE : PLEASE READ ALL THE INSTRUCTIONS CAREFULLY BEFORE ASSEMBLING THIS PRODUCT.

### PRODUCT SPECIFICATION

PRODUCT WEIGHT	-	24.5kg
MAX WEIGHT	-	300kg
DIMENSIONS	-	1080mm x 1300mm x 470mm
SAFE WORKING ZONE	-	2080mm x 1300mm x 2970mm

# WARNING

SERIOUS OR FATAL INJURIES MAY OCCUR FROM INCORRECTLY ASSEMBLED EQUIPMENT. ALWAYS ENSURE BOLTS ARE TIGHTENED CORRECTLY AND ALL PARTS ARE LEVEL AND PLUMB. TO FURTHER REDUCE RISK OF INJURIES OR DEATH PLEASE USE OUR SUGGESTED TOOLS AND PERSONAL PROTECTIVE EQUIPMENT (PPE). WE SUGGEST THAT A MINIMUM OF THREE PEOPLE ARE INVOLVED IN THE ASSEMBLY OF THIS PRODUCT. EACH PERSON SHOULD BE EQUIPPED WITH SAFETY GLASSES, STEEL TOE CAP BOOTS AND EAR PLUGS.

THIS SYMBOL IS AN INDICATION OF THE RECOMMENDED TORQUE EACH BOLT SHOULD BE TIGHTENED TO. THIS VALUE WILL BE DEPENDENT ON THE BOLT TYPE. PLEASE HAND TIGHTEN ALL BOLTS UNTIL YOU SEE THIS SYMBOL.



## TOOLS REQUIRED



HAMMER 17MM SPANNER X2 VACUUM

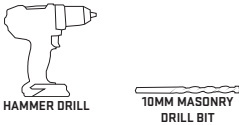

HAMMER DRILL 10MM MASONRY DRILL BIT

ITEM NO.	PART NUMBER	DESCRIPTION	QTY.
1	1.2 WM ARM	21-0107-0C	2
2	1.2 SINGLE BAR CM DNA60	21-0015-0A	1
3	M10X90 HEX HEAD BOLT	10-0008	4
4	M10 WASHER	10-0019	24
5	M10 NYLOCK NUT	10-0024	4
6	M10 SLEEVE ANCHOR BOLT	10-0031	16

## PARTS & ATTACHMENTS

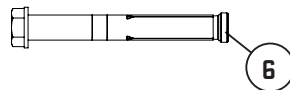
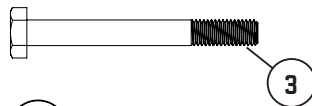
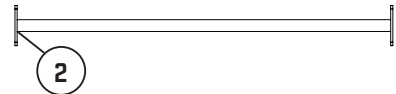
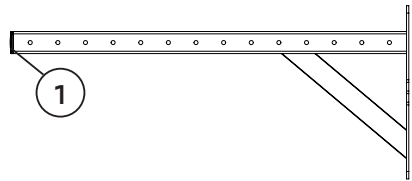

# INSTALLATION

1

BOLT 1QTY 1.2 BAR (21-0015-0A) BETWEEN 2QTY WALL MOUNTED PULL UP ARMS (21-0226-0A) ENSURE ALL BOLTS ARE FACING INWARDS.

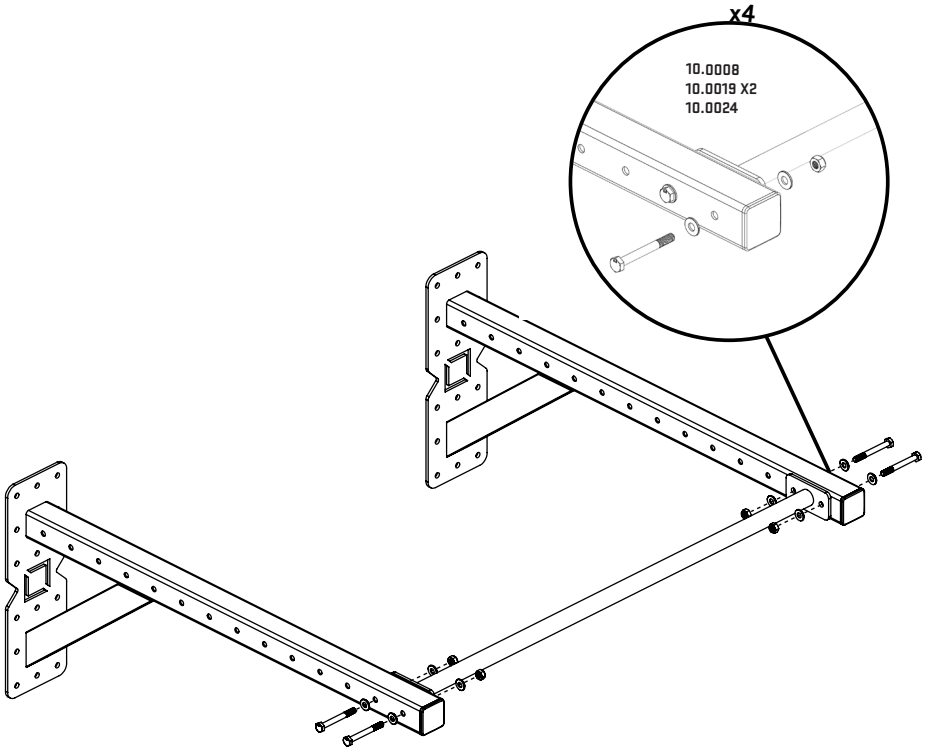

2

BOLT ASSEMBLY TO WALL USING 16 QTY SLEEVE ANCHOR BOLTS (10.0031) AND 16QTY M10 WASHERS (10-0024) DRILL HOLES AND MOUNT USING GUIDE AS SHOWN BELOW, TIGHTEN ALL BOLTS TO SPESIFIED TORQUE.

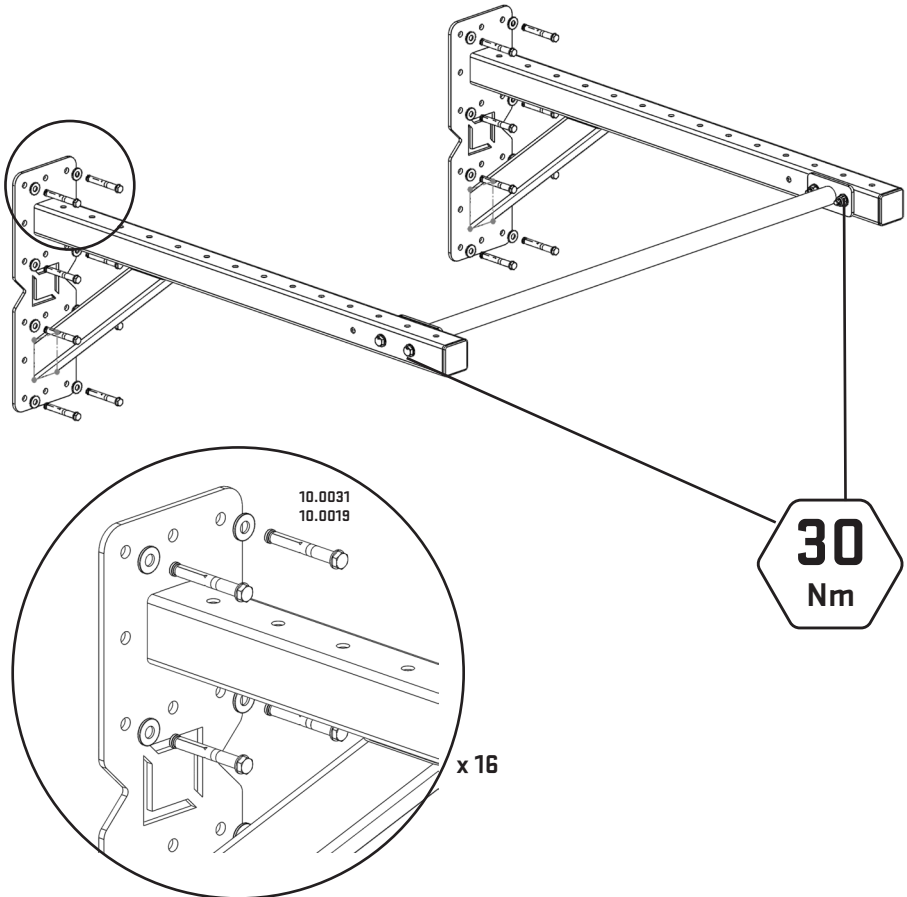

SLEEVE ANCHOR BOLT FITTING

- DRILL 10MM HOLE IN WALL, 90MM DEEP USING PLATE AS A GUIDE.
- VACUUM OUT THE DUST.
- HAMMER SLEEVE ANCHOR INTO THE HOLE.
- TIGHTEN SLEEVE ANCHOR TO SPECIFIED TORQUE USING 13MM SPANNER.

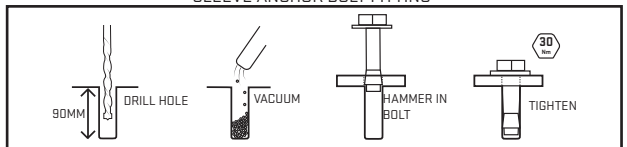

# 1:1 SCALE FASTENERS

M10x80 SLEEVE ANCHOR  
10-0031

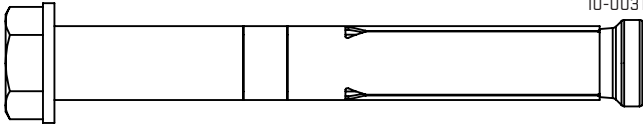

M10x90 BOLT  
10-0008

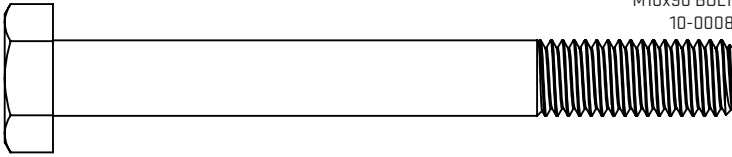

M10 FLAT WASHER  
10-0019

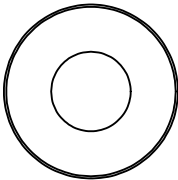

NYLOCK NUT  
10-0024

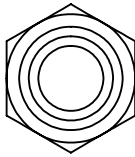

FOR TERMS AND CONDITIONS VISIT OUR WEBSITE AT  
[www.blkboxfitness.com/pages/terms-conditions](http://www.blkboxfitness.com/pages/terms-conditions)

GET IN TOUCH  
TEL: 028 9045 4123  
EMAIL: [info@blkboxfitness.com](mailto:info@blkboxfitness.com)

DISCOVER MORE AT:  
[www.blkboxfitness.com](http://www.blkboxfitness.com)