

BLK BOX SINGLE BARBELL HANGER

21-0168

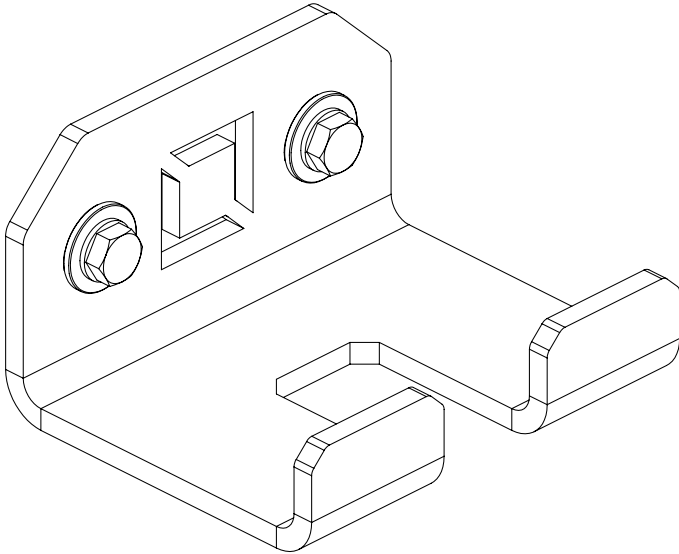

OWNERS MANUAL & QUICK START GUIDE

PRODUCT SPECIFICATION

NOTE : PLEASE READ ALL THE INSTRUCTIONS
CAREFULLY BEFORE ASSEMBLING THIS PRODUCT.

PRODUCT WEIGHT	-	2kg
DIMENSIONS	-	125mm x 104mm x 71mm

WARNING

SERIOUS OR FATAL INJURIES MAY OCCUR FROM INCORRECTLY ASSEMBLED EQUIPMENT. ALWAYS ENSURE BOLTS ARE TIGHTENED CORRECTLY AND ALL PARTS ARE LEVEL AND PLUMB. TO FURTHER REDUCE RISK OF INJURIES OR DEATH PLEASE USE OUR SUGGESTED TOOLS AND PERSONAL PROTECTIVE EQUIPMENT (PPE). WE SUGGEST THAT A MINIMUM OF THREE PEOPLE ARE INVOLVED IN THE ASSEMBLY OF THIS PRODUCT. EACH PERSON SHOULD BE EQUIPPED WITH SAFETY GLASSES, STEEL TOE CAP BOOTS AND EAR PLUGS.

THIS SYMBOL IS AN INDICATION OF THE RECOMMENDED TORQUE EACH BOLT SHOULD BE TIGHTENED TO. THIS VALUE WILL BE DEPENDENT ON THE BOLT TYPE. PLEASE HAND TIGHTEN ALL BOLTS UNTIL YOU SEE THIS SYMBOL.



TOOLS REQUIRED



HAMMER DRILL

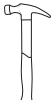

HAMMER



17MM SPANNER X2



10MM MASONRY DRILL BIT

No.	Name	SKU	QTY
1	SINGLE BARBELL HOLDER	20-0070	1
2	M10X80 SLEEVE ANCHOR	10-0031	2
3	M10 FLAT WASHER	10-0019	2

PARTS & ATTACHMENTS

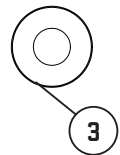
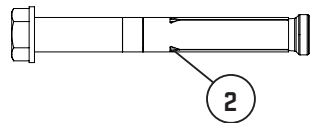
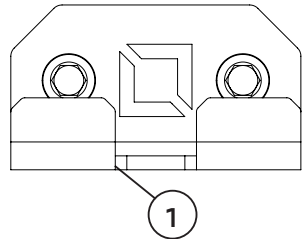

INSTALLATION

1

MEASURE, MARK AND DRILL HOLES USING GUIDES PROVIDED.

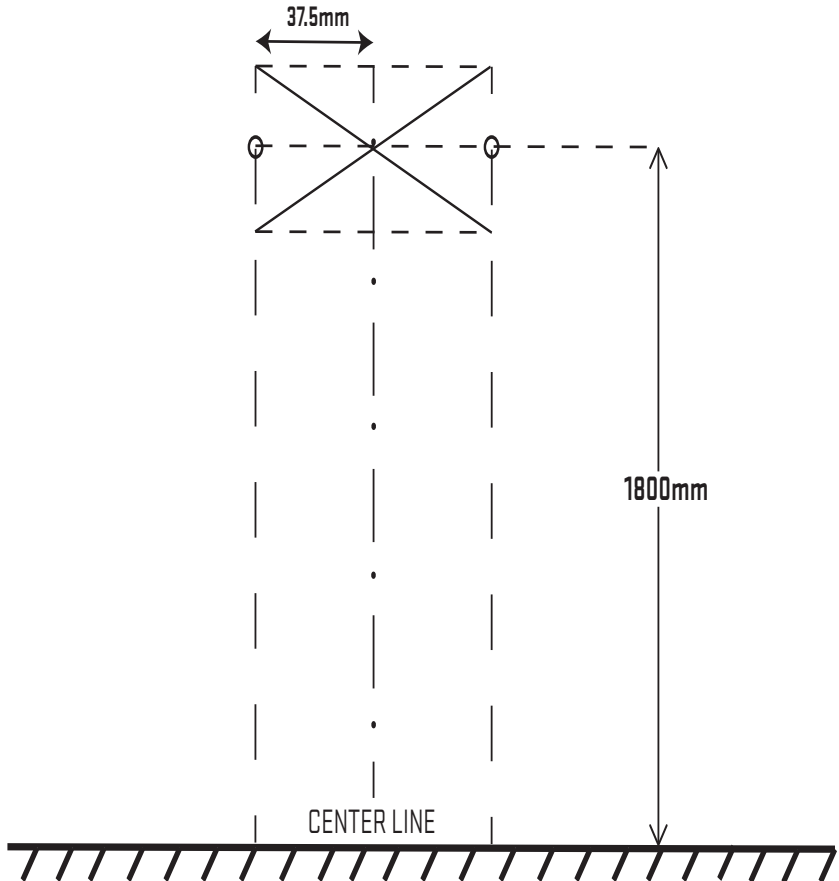

- DRILL 10MM HOLE INTO THE WALL, 90MM DEEP
- VACUUM OUT THE DUST.

SLEEVE ANCHOR BOLT FITTING

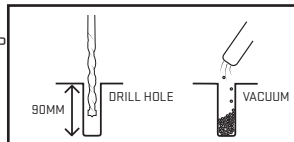

2

MOUNT THE SINGLE BARBELL HOLDER (20-0070) TO THE WALL USING SLEEVE ANCHORS (10-0031) AND WASHERS (10-0019) AS SHOWN IN THE GUIDE BELOW. TIGHTEN BOLTS TO SPECIFIED TORQUE.

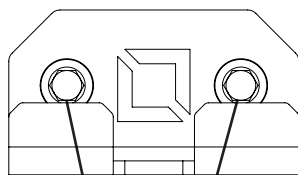
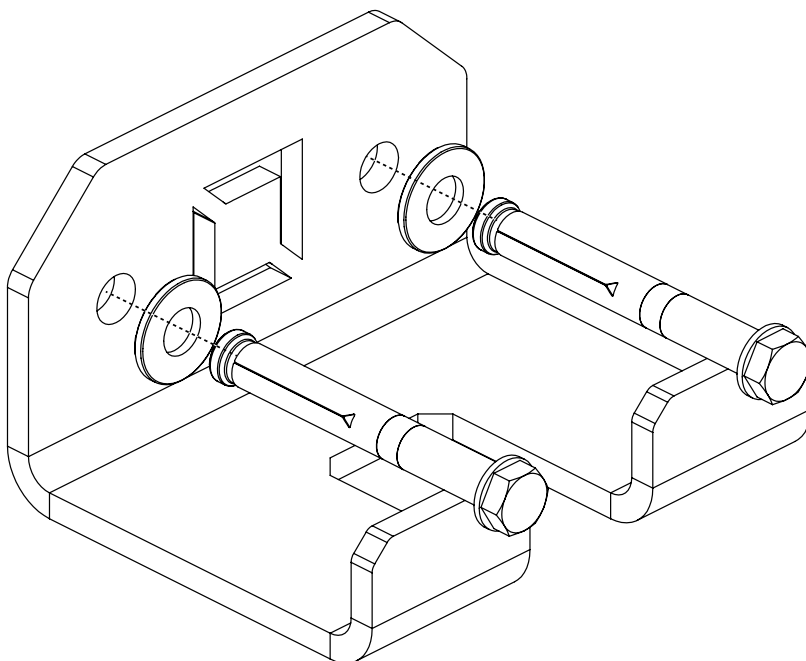

x2
30
Nm

- HAMMER SLEEVE ANCHOR INTO THE HOLE.
- TIGHTEN SLEEVE ANCHOR TO SPECIFIED TORQUE USING 13MM SPANNER.

SLEEVE ANCHOR BOLT FITTING

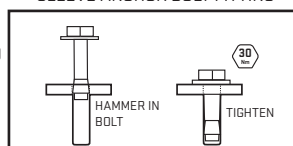

1:1 SCALE FASTENERS

M10x80 SLEEVE ANCHOR
10-0031

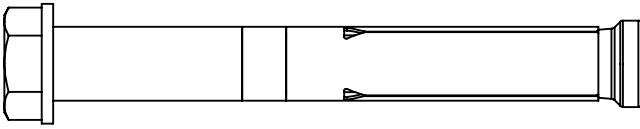

M10 FLAT WASHER
10-0019

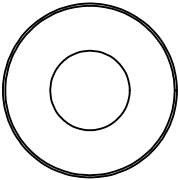

FOR TERMS AND CONDITIONS VISIT OUR WEBSITE AT
www.blkboxfitness.com/pages/terms-conditions

GET IN TOUCH
TEL: 028 9045 4123
EMAIL: info@blkboxfitness.com

DISCOVER MORE AT:
www.blkboxfitness.com