

BLK BOX HARLAND SQUAT STAND

21-0704-0A

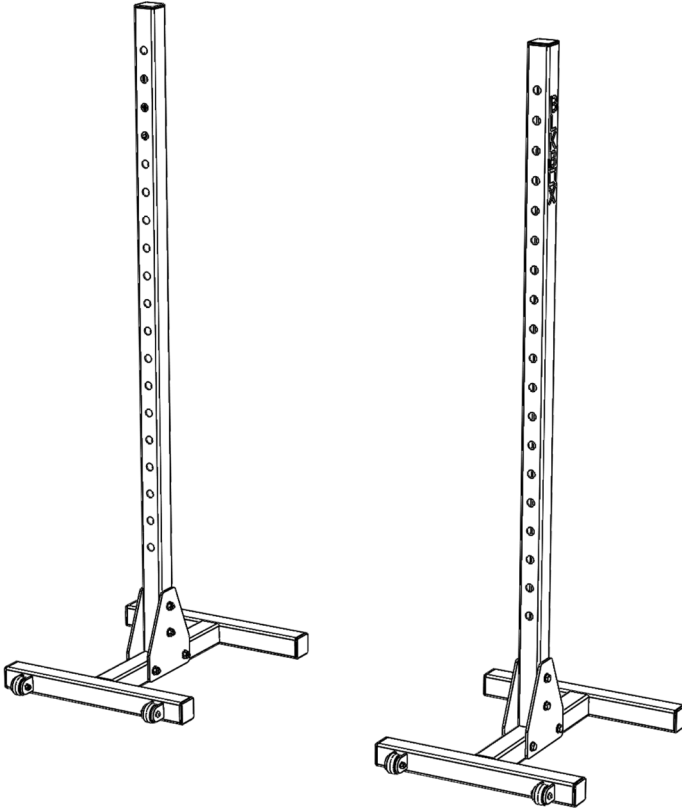

PRODUCT SPECIFICATION

PRODUCT WEIGHT	-	65kg
MAX USER WEIGHT	-	n/a
MAX USER	-	1
MAX TRAINING WEIGHT	-	350kg
DIMENSIONS	-	1700mm x 650mm x 1820mm
SAFE WORKING ZONE	-	2700mm x 1850mm x 2684mm

OWNERS MANUAL & QUICK START GUIDE

NOTE : PLEASE READ ALL THE INSTRUCTIONS CAREFULLY BEFORE ASSEMBLING THIS PRODUCT.

WARNING

SERIOUS OR FATAL INJURIES MAY OCCUR FROM INCORRECTLY ASSEMBLED EQUIPMENT. ALWAYS ENSURE BOLTS ARE TIGHTENED CORRECTLY AND ALL PARTS ARE LEVEL AND PLUMB. TO FURTHER REDUCE RISK OF INJURIES OR DEATH PLEASE USE OUR SUGGESTED TOOLS AND PERSONAL PROTECTIVE EQUIPMENT (PPE). WE SUGGEST THAT A MINIMUM OF THREE PEOPLE ARE INVOLVED IN THE ASSEMBLY OF THIS PRODUCT. EACH PERSON SHOULD BE EQUIPPED WITH SAFETY GLASSES, STEEL TOE CAP BOOTS AND EAR PLUGS.

PLEASE BE AWARE OF THIS SYMBOL AS AN INDICATION TO CHECK THAT A PART IS LEVEL OR PLUMB.



THIS SYMBOL IS AN INDICATION OF THE RECOMMENDED TORQUE EACH BOLT SHOULD BE TIGHTENED TO. THIS VALUE WILL BE DEPENDENT ON THE BOLT TYPE. PLEASE HAND TIGHTEN ALL BOLTS UNTIL YOU SEE THIS SYMBOL.



TOOLS REQUIRED



2x 17MM SPANNER

PARTS & ATTACHMENTS

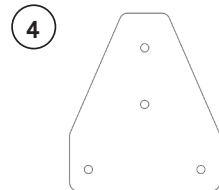
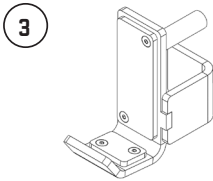
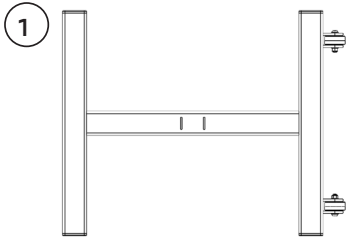

ITEM NO.	PART NUMBER	DESCRIPTION	QTY.
1	HARLAND SQUAT STAND BASE - SA	21-0702-0A	2
2	HARLAND SQUAT STAND UPRIGHT - SA	21-0703-0A	2
3	BASIC J HOOK WELDED WT HOLES		1
4	GOLIATH QUARTER RACK SIDE PLATE	20-0472-0A	4
5	M10X90 HEX HEAD BOLT	10-0008	8
6	M10 WASHER	10-0019	16
7	M10 NYLOCK NUT	10-0024	8

ASSEMBLY

1

PLACE 1QTY OF THE HARLAD SQUAT STAND UPRIGHT (21-0703-0A) INTO 1QTY OF THE HARLAND SQUAT STAND BASE (21-0703-0A) -ENSURING THE TABS OF THE UPRIGHT ALIGN WITH THE HOLES IN THE BASE. PLEASE ALSO ENSURE THE BLK BOX LOGO IF FAC-ING OUTWARDS FROM THE RACK.

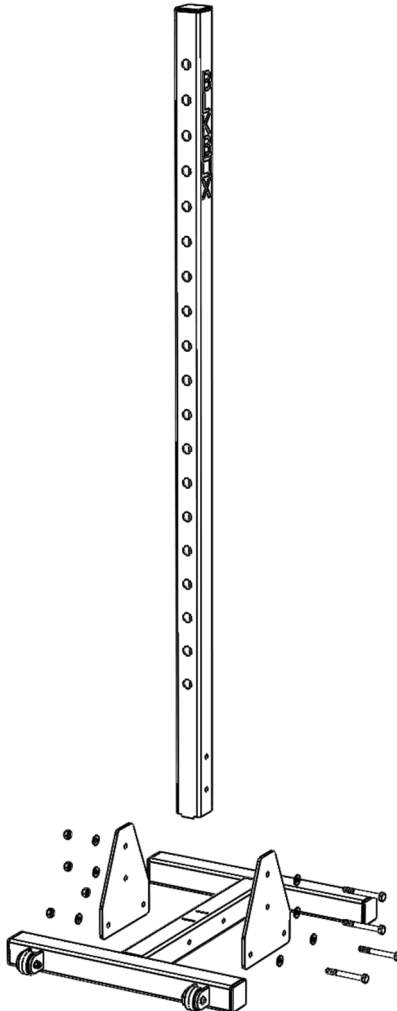

FASTEN THE UPRIGHT IN PLACE BY PLACING 2QTY GOLIATH SIDE PLATES (20-0472-0A) EITHER SIDE OF THE PLATE, AND FASTENING USING 4QTY M10X90 HEX HEAD BOLT (10-0008), 8QTY M10 WASHER (10-0019) AND 4QTY M10 NYLOC NUT (10-0024).

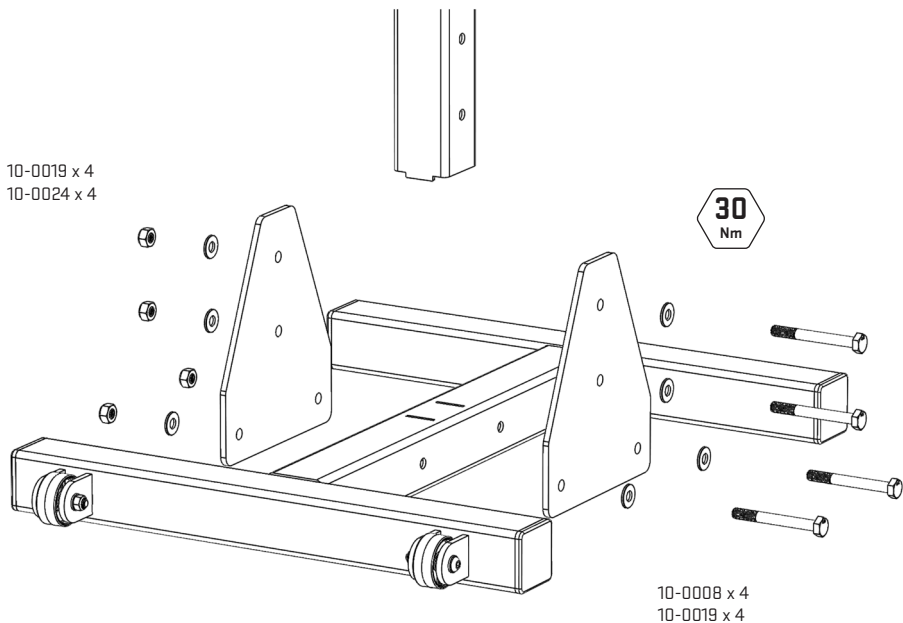

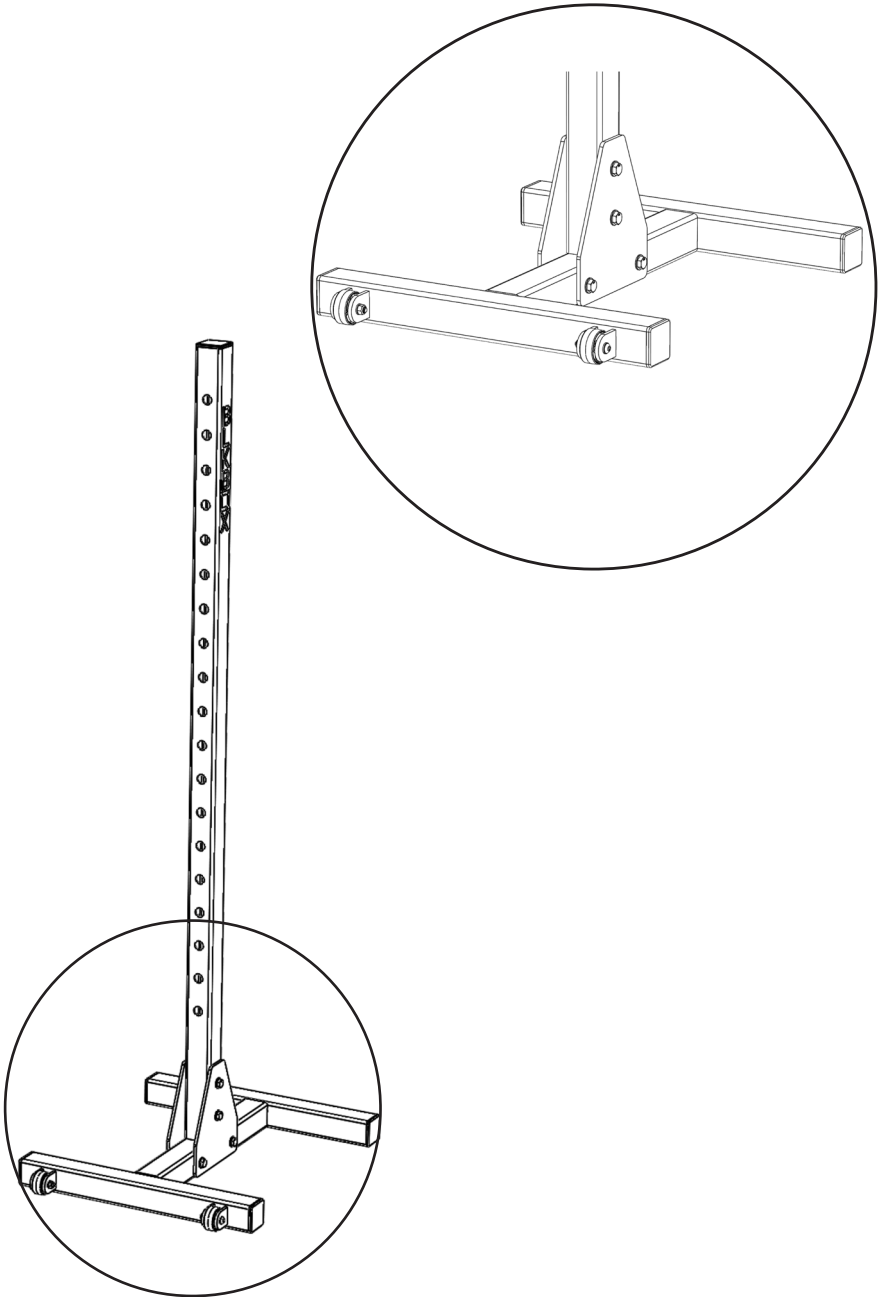

2

ONCE COMPLETED, REPEAT STEP USING OTHER UPRIGHT AND BASE. ONCE AGAIN ENSURE TABS ALIGN WITH SLOTS, AND THE BLK BOX LOGO FACES OUTWARDS FROM THE RACK.

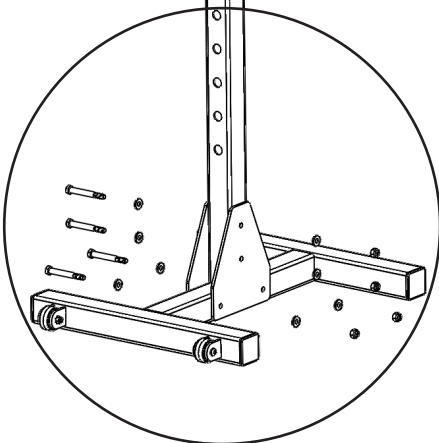
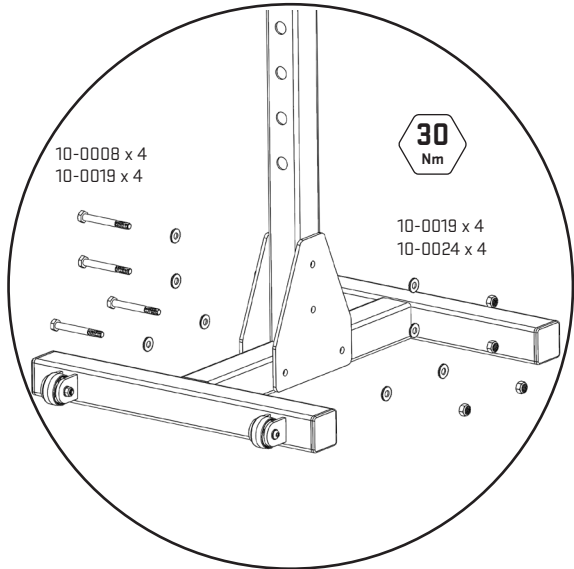

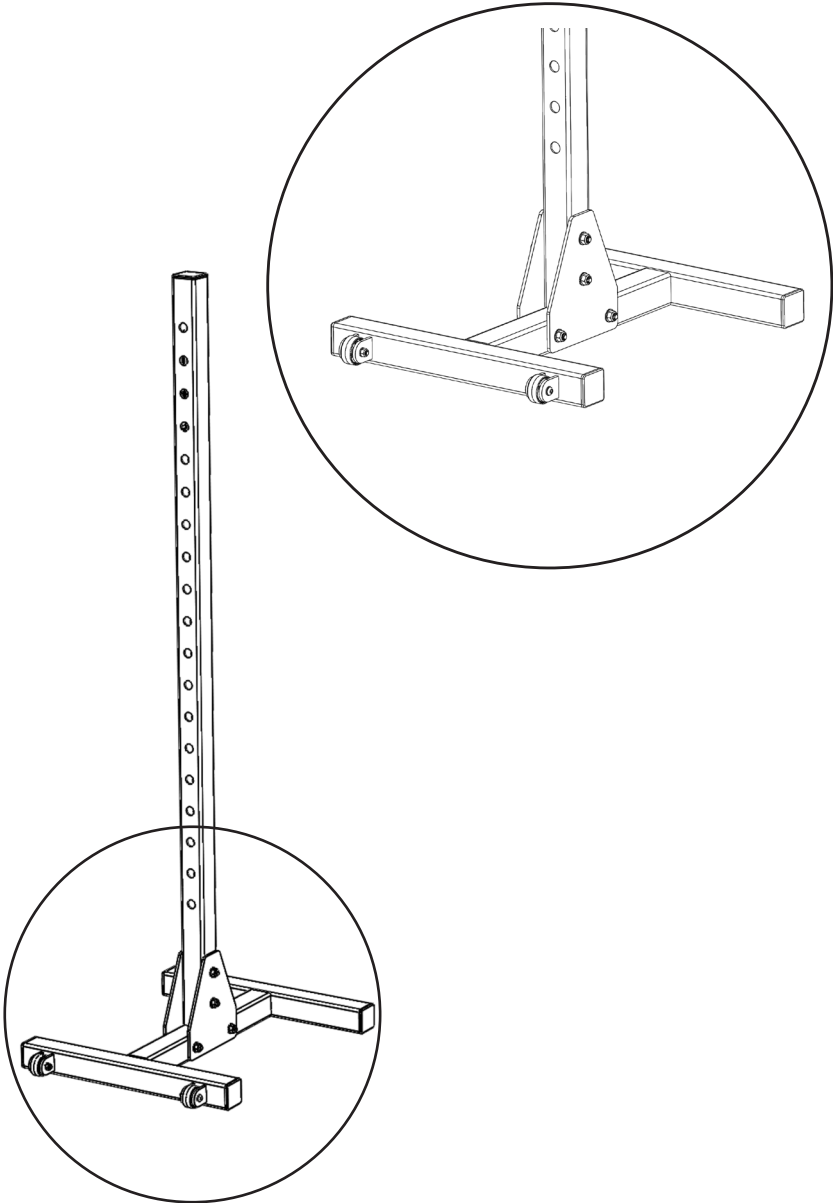

3

THE HARLAND SQUAT STAND HAS NOW BEEN ASSEMBLED

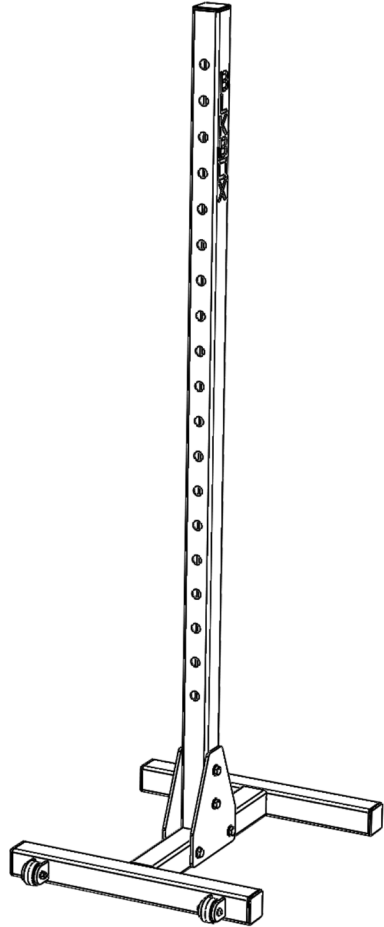
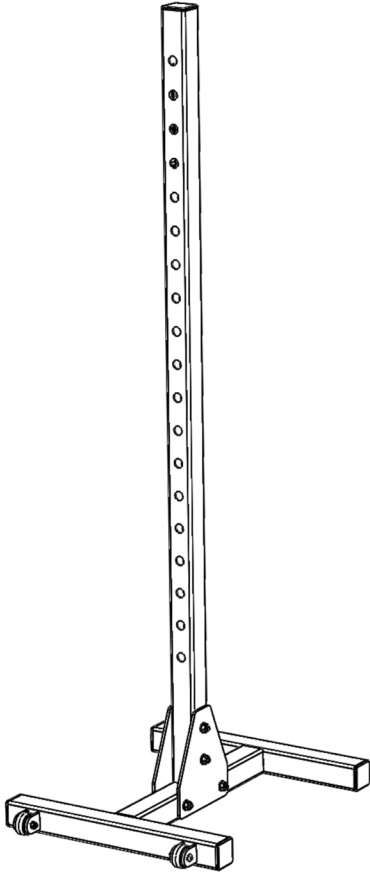

1:1 SCALE FASTENERS

M10 x 90 HEX HEAD BOLT
10-0008

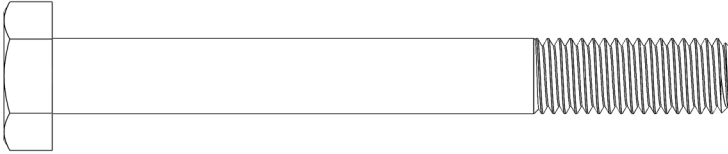

M10 WASHER
10-0019

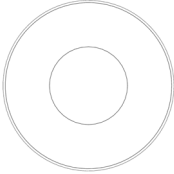

M10 NYLOC NUT
10-0024

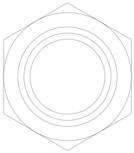

FOR TERMS AND CONDITIONS VISIT OUR WEBSITE AT
www.blkboxfitness.com/pages/terms-conditions

GET IN TOUCH
TEL: 028 9045 4123
EMAIL: info@blkboxfitness.com

DISCOVER MORE AT:
www.blkboxfitness.com

THIS IS A BLANK PAGE

THIS IS A BLANK PAGE