

# BLK BOX

## GOLIATH WALL MOUNTED FUNCTIONAL RIG

### 4 BAY

21-0816

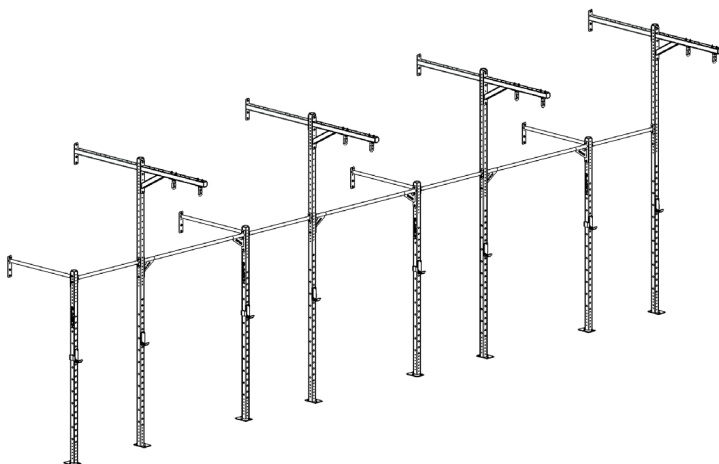

### PRODUCT SPECIFICATION

PRODUCT WEIGHT	-	260kg
MAX USER WEIGHT	-	125kg
MAX USER	-	4
MAX TRAINING WEIGHT	-	300kg
DIMENSIONS	-	10130mm x 2220mm x 3600mm

#### OWNERS MANUAL & QUICK START GUIDE

NOTE : PLEASE READ ALL THE INSTRUCTIONS CAREFULLY BEFORE ASSEMBLING THIS PRODUCT.

# WARNING

SERIOUS OR FATAL INJURIES MAY OCCUR FROM INCORRECTLY ASSEMBLED EQUIPMENT. ALWAYS ENSURE BOLTS ARE TIGHTENED CORRECTLY AND ALL PARTS ARE LEVEL AND PLUMB. TO FURTHER REDUCE RISK OF INJURIES OR DEATH PLEASE USE OUR SUGGESTED TOOLS AND PERSONAL PROTECTIVE EQUIPMENT (PPE). WE SUGGEST THAT A MINIMUM OF THREE PEOPLE ARE INVOLVED IN THE ASSEMBLY OF THIS PRODUCT. EACH PERSON SHOULD BE EQUIPPED WITH SAFETY GLASSES, STEEL TOE CAP BOOTS AND EAR PLUGS.

PLEASE BE AWARE OF THIS SYMBOL AS AN INDICATION TO CHECK THAT A PART IS LEVEL OR PLUMB.



THIS SYMBOL IS AN INDICATION OF THE RECOMMENDED TORQUE EACH BOLT SHOULD BE TIGHTENED TO. THIS VALUE WILL BE DEPENDENT ON THE BOLT TYPE. PLEASE HAND TIGHTEN ALL BOLTS UNTIL YOU SEE THIS SYMBOL.



## TOOLS REQUIRED

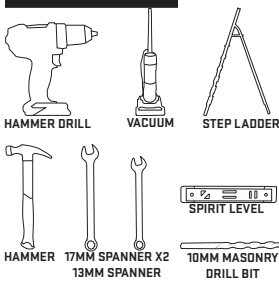

## PARTS & ATTACHMENTS

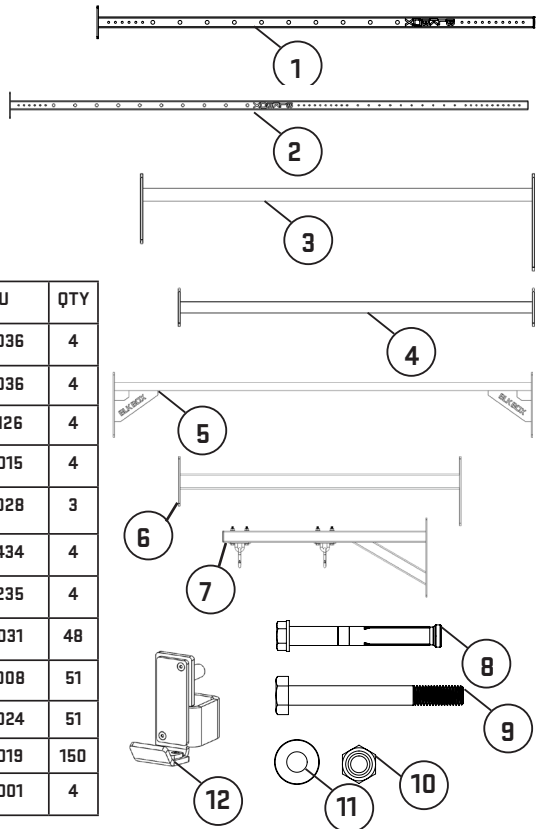

No.	Name	SKU	QTY
1	2.4 UPRIGHT DNA60 WITH FEET	21-0036	4
2	3.6 UPRIGHT DNA60 WITH FEET	21-0036	4
3	1.2 SINGLE BAR WM DNA60	21-0126	4
4	1.2 SINGLE BAR CM DNA60	21-0015	4
5	1.8 SINGLE BAR CM DNA60	21-0028	3
6	1.2 BOX WM DNA60	21-0434	4
7	1.2 GOLIATH ARM	21-0235	4
8	M10X80 SLEEVE ANCHOR	10-0031	48
9	M10X90 BOLT	10-0008	51
10	M10 NYLOCK NUT	10-0024	51
11	M10 FLAT WASHER	10-0019	150
12	J-HOOKS PAIR	16-0001	4

# ASSEMBLY

1

BOLT 1QTY 1.2 SINGLE BAR CM (21.0015) BETWEEN 1QTY 2.4 UPRIGHT (21-0036), AND 1QTY 3.6 UPRIGHT (21-0038) AND BOLT 1QTY 1.2 SINGLE BAR WM (21-0126) WITH BOLTS ASSEMBLY AS SHOWN. ENSURE LOGO ON UPRIGHTS ARE FACING OUTWARD AND ALL BOLTS FACING INWARDS. BOLT 1QTY 1.2 BOX WM (21-0434) AND 1 QTY GOLIATH ARM (21-0235) TO 1QTY 3.6 UPRIGHT (21-0038). REPEAT FOR EACH BAY.

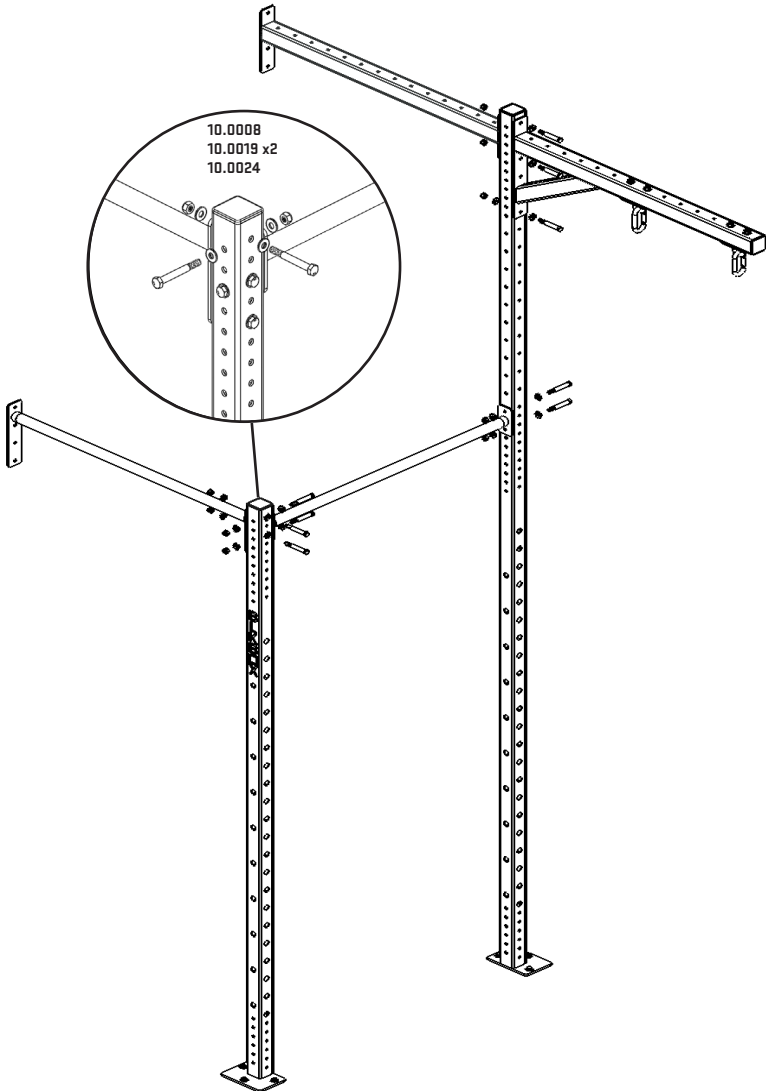

2

POSITION 1 BAY 1740MM FROM NEXT BAY. BOLT 1QTY 1.8 SINGLE BAR (21-0028) TO THE SIDE OF THE 3.6 UPRIGHT (21-0038) AND 2.4 UPRIGHT (21-0036) REUSING BOLT ASSEMBLY AS SHOWN. ENSURE THAT BOLTS ARE FACING INWARD.

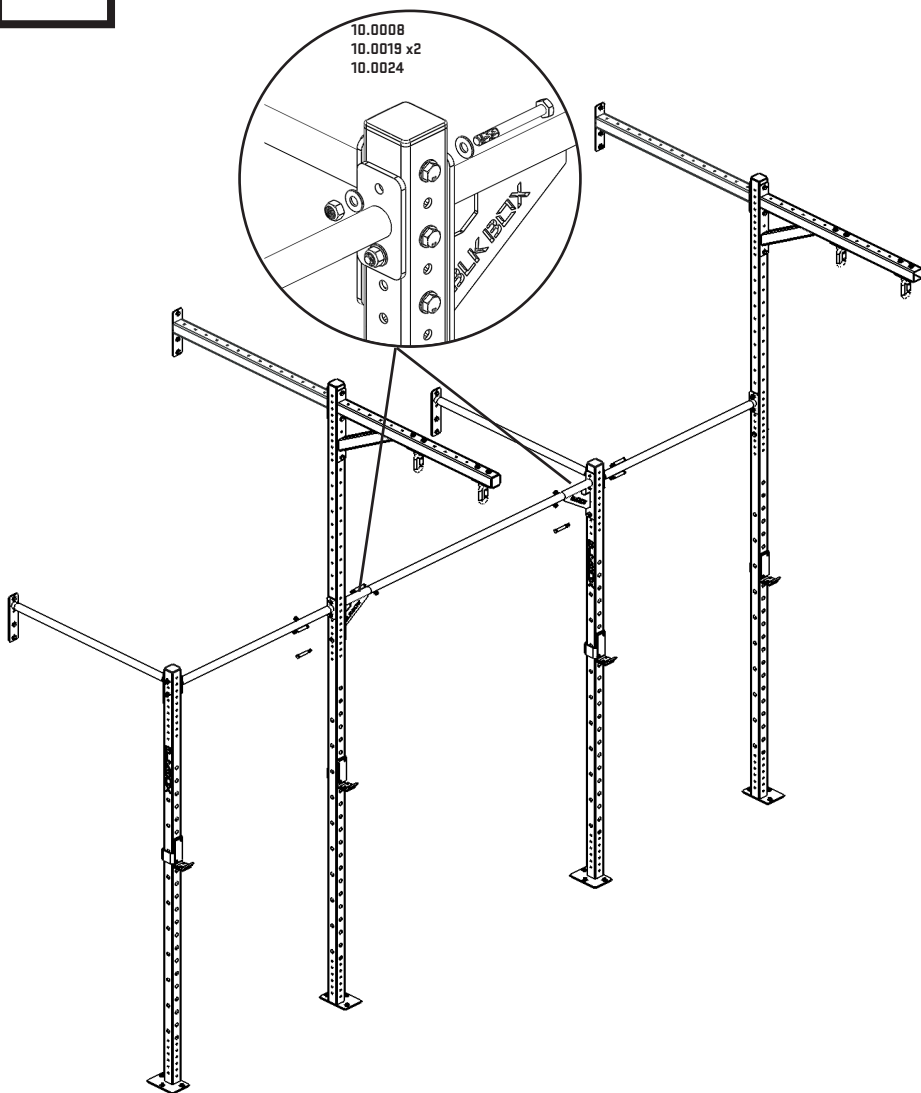

# 3

TIGHTEN ALL BOLT ASSEMBLIES WITHIN THE ELLIPSES TO THE 30Nm TORQUE . ENSURE UPRIGHTS ARE PLUMB. DRILL AND SECURE UPRIGHTS, 1.2 BOX WM (21-0434) AND 1.2 `SINGLE BAR WM (21-0126) AS SHOWN IN GUIDE.

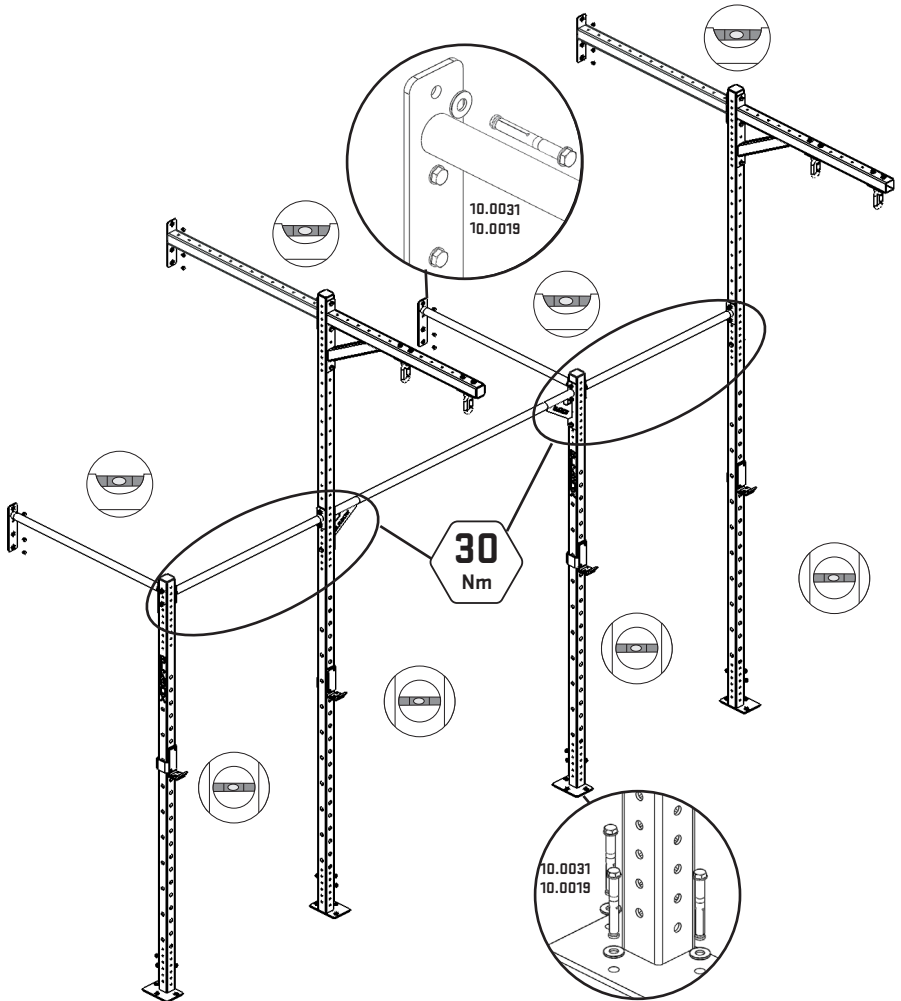

SLEEVE ANCHOR BOLT FITTING

- DRILL 10MM HOLE, 90MM DEEP USING PLATE AS A GUIDE.
- VACUUM OUT THE DUST.
- HAMMER SLEEVE ANCHOR INTO THE HOLE.
- TIGHTEN SLEEVE ANCHOR TO SPECIFIED TORQUE USING 13MM SPANNER.

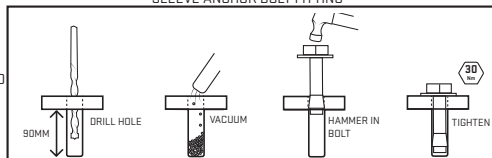

4

REPEAT FIRST THREE STEPS FOR ADDITIONAL BAYS.

## 1:1 SCALE FASTENERS

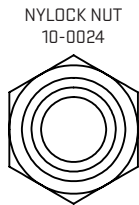
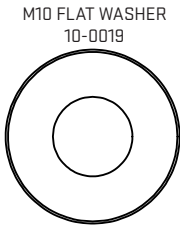
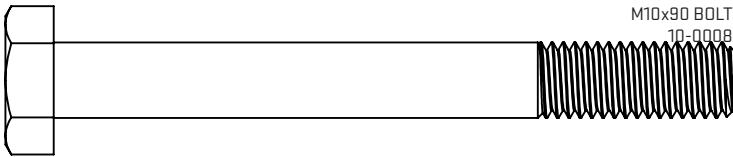
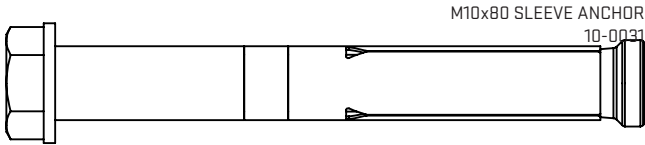

FOR TERMS AND CONDITIONS VISIT OUR WEBSITE AT  
[www.blkboxfitness.com/pages/terms-conditions](http://www.blkboxfitness.com/pages/terms-conditions)

GET IN TOUCH  
TEL: 028 9045 4123  
EMAIL: [info@blkboxfitness.com](mailto:info@blkboxfitness.com)

DISCOVER MORE AT:  
[www.blkboxfitness.com](http://www.blkboxfitness.com)