

BLK BOX COMPACT RACK DNA60

21-0109-0K

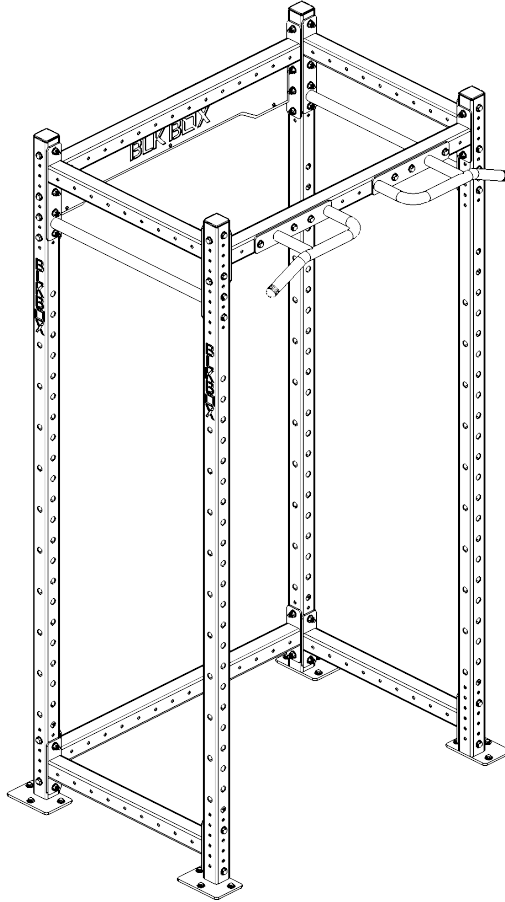

PRODUCT SPECIFICATION

OWNERS MANUAL & QUICK START GUIDE

NOTE : PLEASE READ ALL THE INSTRUCTIONS
CAREFULLY BEFORE ASSEMBLING THIS PRODUCT.

| | | |
|---------------------|---|--------------|
| PRODUCT WEIGHT | - | 000kg |
| MAX USER WEIGHT | - | 000kg |
| MAX TRAINING WEIGHT | - | 000kg |
| DIMENSIONS | - | mm x mm x mm |
| SAFE WORKING ZONE | - | mm x mm x mm |

WARNING

SERIOUS OR FATAL INJURIES MAY OCCUR FROM INCORRECTLY ASSEMBLED EQUIPMENT. ALWAYS ENSURE BOLTS ARE TIGHTENED CORRECTLY AND ALL PARTS ARE LEVEL AND PLUMB. TO FURTHER REDUCE RISK OF INJURIES OR DEATH PLEASE USE OUR SUGGESTED TOOLS AND PERSONAL PROTECTIVE EQUIPMENT (PPE). WE SUGGEST THAT A MINIMUM OF THREE PEOPLE ARE INVOLVED IN THE ASSEMBLY OF THIS PRODUCT. EACH PERSON SHOULD BE EQUIPPED WITH SAFETY GLASSES, STEEL TOE CAP BOOTS AND EAR PLUGS.

PLEASE BE AWARE OF THIS SYMBOL AS AN INDICATION TO CHECK THAT A PART IS LEVEL OR PLUMB.



THIS SYMBOL IS AN INDICATION OF THE RECOMMENDED TORQUE EACH BOLT SHOULD BE TIGHTENED TO. THIS VALUE WILL BE DEPENDENT ON THE BOLT TYPE. PLEASE HAND TIGHTEN ALL BOLTS UNTIL YOU SEE THIS SYMBOL.



TOOLS REQUIRED

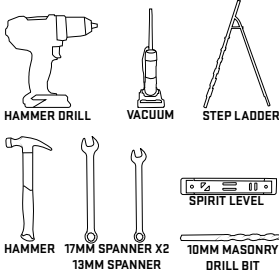

| No. | Name | SKU | QTY |
|-----|-----------------------------|------------|-----|
| 1 | 2.4 UPRIGHT DNA60 WITH FEET | 21-0036-0A | 4 |
| 2 | 1.2 BRANDING BOX CM DNA60 | 21-0017-0A | 1 |
| 3 | 1.2 BOX CM DNA60 | 21-0013-0A | 2 |
| 4 | 0.7 BOX CM DNA60 | 21-0036-0A | 2 |
| 5 | 0.7 BOX & BAR CM DNA60 | 21-0011-0A | 2 |
| 6 | MULTIGRIPS DNA60 | 21-0151-0A | 1 |
| 7 | M10X80 SLEEVE ANCHOR | 16-0031 | 12 |
| 8 | M10X90 BOLT | 10-0008 | 46 |
| 9 | M10 FLAT WASHER | 10-0019 | 104 |
| 10 | M10 NYLOCK NUT | 10-0024 | 46 |
| 11 | J-HOOKS PAIR | 16-0001 | 1 |

PARTS & ATTACHMENTS

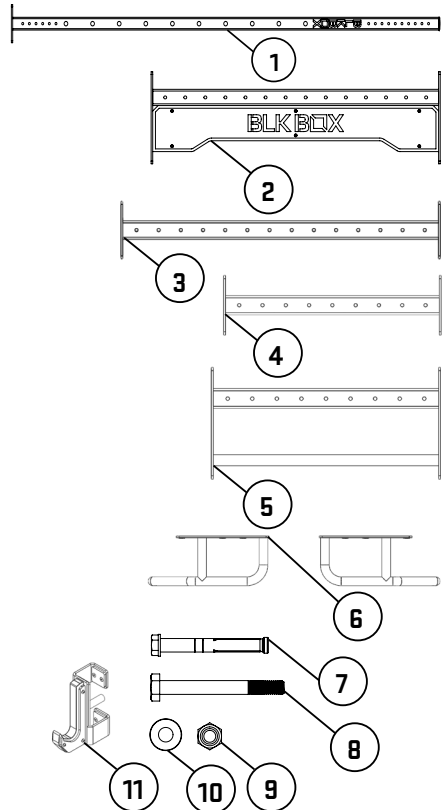

ASSEMBLY

1

BOLT 1QTY BRANDING BOX [21-0017-0A] AND 1QTY 1.2 BOX [21-0013-0A] BETWEEN 2QTY UPRIGHTS [21-0036-0A] WITH BOLTS ASSEMBLY AS SHOWN. ENSURE LOGOS ON BRANDING BOX [21-0017-0A] IS FACING FORWARD, LOGOS ON UPRIGHTS ARE FACING OUTWARD AND ALL BOLTS FACING INWARDS.

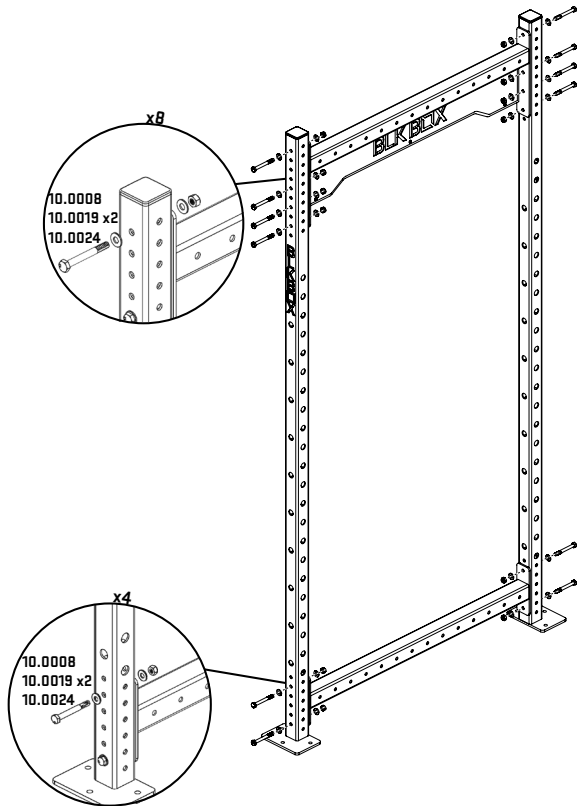

2

BOLT 1QTY 1.2 BOX (21-0013-0A) BETWEEN 2QTY UPRIGHTS (21-0036-0A) AND CONNECT TO EXISTING ASSEMBLY USING 2QTY 0.7 BOX & BAR (21-0036-0A) AND 2QTY 0.7 BOX (21-0011-0A) WITH BOLT ASSEMBLY AS SHOWN. BOLT 1QTY MULTIGRIPS (21-0151-0A) TO 1QTY 1.2 BOX (21-0013-0A) WITH BOLT ASSEMBLY AS SHOWN ENSURE LOGO ON UPRIGHTS ARE FACING OUTWARD AND BOLTS ARE FACING INWARD.

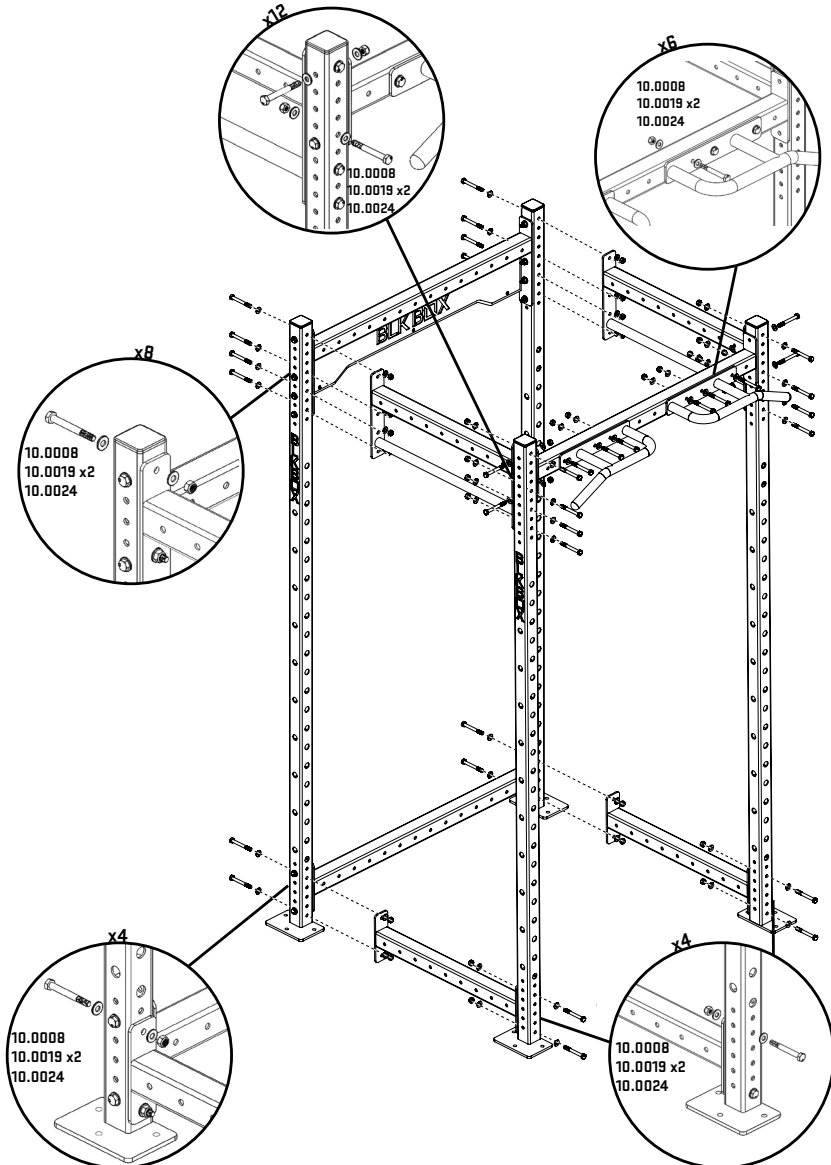

3

TIGHTEN ALL BOLT ASSEMBLIES WITHIN THE CIRCLE TO SPECIFIED TORQUE. ENSURE ALL UPRIGHTS ARE PLUMB. DRILL AND SECURE THE MIDDLE HOLE ON EACH UPRIGHT AS SHOWN IN GUIDE. REMOVE ALL BOTTOM CROSSMEMBERS, DRILL AND SECURE REMAINING HOLES ON UPRIGHTS AS SHOWN IN GUIDE. REATTACH THE BOTTOM CROSSMEMBERS.

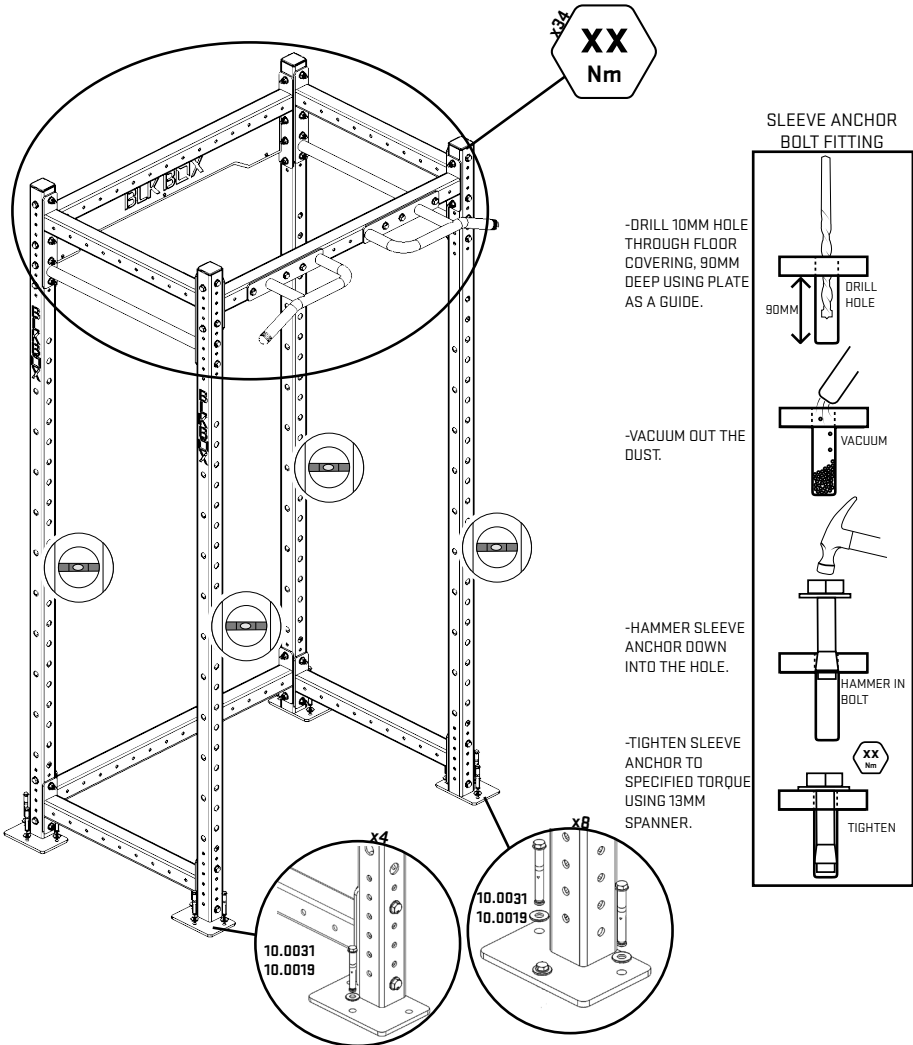

1:1 SCALE FASTENERS

M10x80 SLEEVE ANCHOR
10-0031

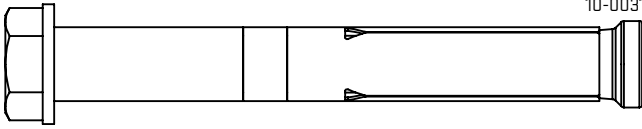

M10x90 BOLT
10-0008

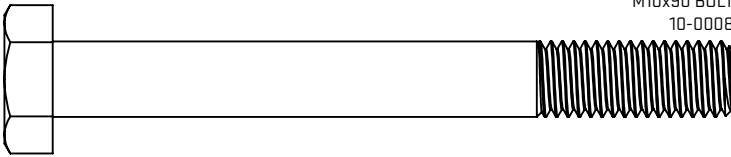

M10 FLAT WASHER
10-0019

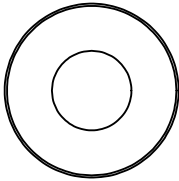

NYLOCK NUT
10-0024

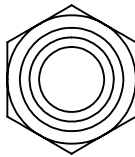

FOR TERMS AND CONDITIONS VISIT OUR WEBSITE AT
www.blkboxfitness.com/pages/terms-conditions

GET IN TOUCH
TEL: 028 9045 4123
EMAIL: info@blkboxfitness.com

DISCOVER MORE AT:
www.blkboxfitness.com

THIS IS A BLANK PAGE