

# BLK BOX BASE CAMP

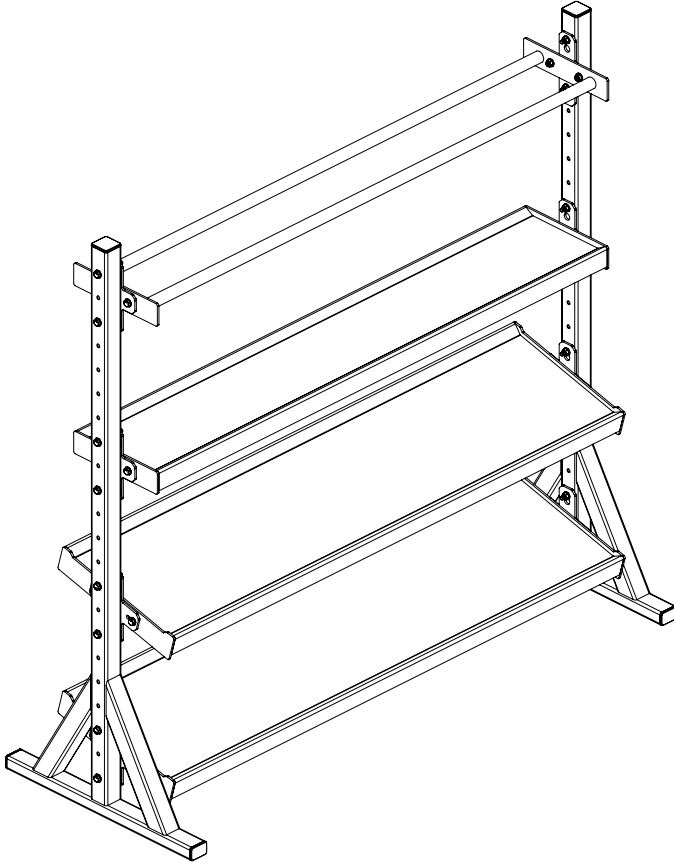

## PRODUCT SPECIFICATION

### OWNERS MANUAL & QUICK START GUIDE

NOTE : PLEASE READ ALL THE INSTRUCTIONS CAREFULLY BEFORE ASSEMBLING THIS PRODUCT.

PRODUCT WEIGHT	-	120kg
DIMENSIONS	-	1860mm x 1768mm x 700mm
SAFE WORKING ZONE	-	2360mm x 2268mm x 1700mm

# WARNING

SERIOUS OR FATAL INJURIES MAY OCCUR FROM INCORRECTLY ASSEMBLED EQUIPMENT. ALWAYS ENSURE BOLTS ARE TIGHTENED CORRECTLY AND ALL PARTS ARE LEVEL AND PLUMB. TO FURTHER REDUCE RISK OF INJURIES OR DEATH PLEASE USE OUR SUGGESTED TOOLS AND PERSONAL PROTECTIVE EQUIPMENT (PPE). WE SUGGEST THAT A MINIMUM OF THREE PEOPLE ARE INVOLVED IN THE ASSEMBLY OF THIS PRODUCT. EACH PERSON SHOULD BE EQUIPPED WITH SAFETY GLASSES, STEEL TOE CAP BOOTS AND EAR PLUGS.

THIS SYMBOL IS AN INDICATION OF THE RECOMMENDED TORQUE EACH BOLT SHOULD BE TIGHTENED TO. THIS VALUE WILL BE DEPENDENT ON THE BOLT TYPE. PLEASE HAND TIGHTEN ALL BOLTS UNTIL YOU SEE THIS SYMBOL.



## TOOLS REQUIRED



17MM SPÄNNER X2

No.	Name	SKU	QTY
1	BASECAMP UPRIGHT FRAME	21-0088-0A	2
2	1.8 BALL SHELF	21-0064-0A	1
3	1.8 FLAT SHELF	21-0066-0B	1
4	1.8 DUMBBELL SHELF	21-0066-0B	2
5	BOLT ON FLAT SIDE PLATE	20-0049-0A	4
6	BOLT ON ANGLED SIDE PLATE	20-0048-0B	4
7	M10X90 BOLT	10-0008	16
8	M10 FLAT WASHER	10-0019	32
9	M10 NYLOCK NUT	10-0024	32
10	M10X30 BOLT	10-0001	16

## PARTS & ATTACHMENTS

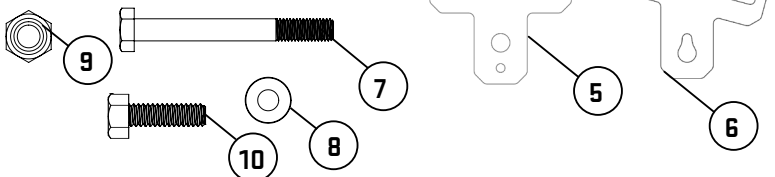
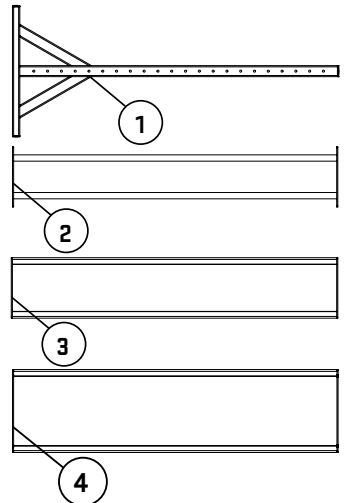

# ASSEMBLY

1

BOLT 4QTY FLAT SIDE PLATE (20-0049-0A) AND 4QTY ANGLED SIDE PLATE (20-0048-0B) TO 2QTY BASECAMP UPRIGHT FRAMES (21-0088-0A) WITH BOLTS ASSEMBLY AS SHOWN. ALL BOLTS FACING INWARDS.

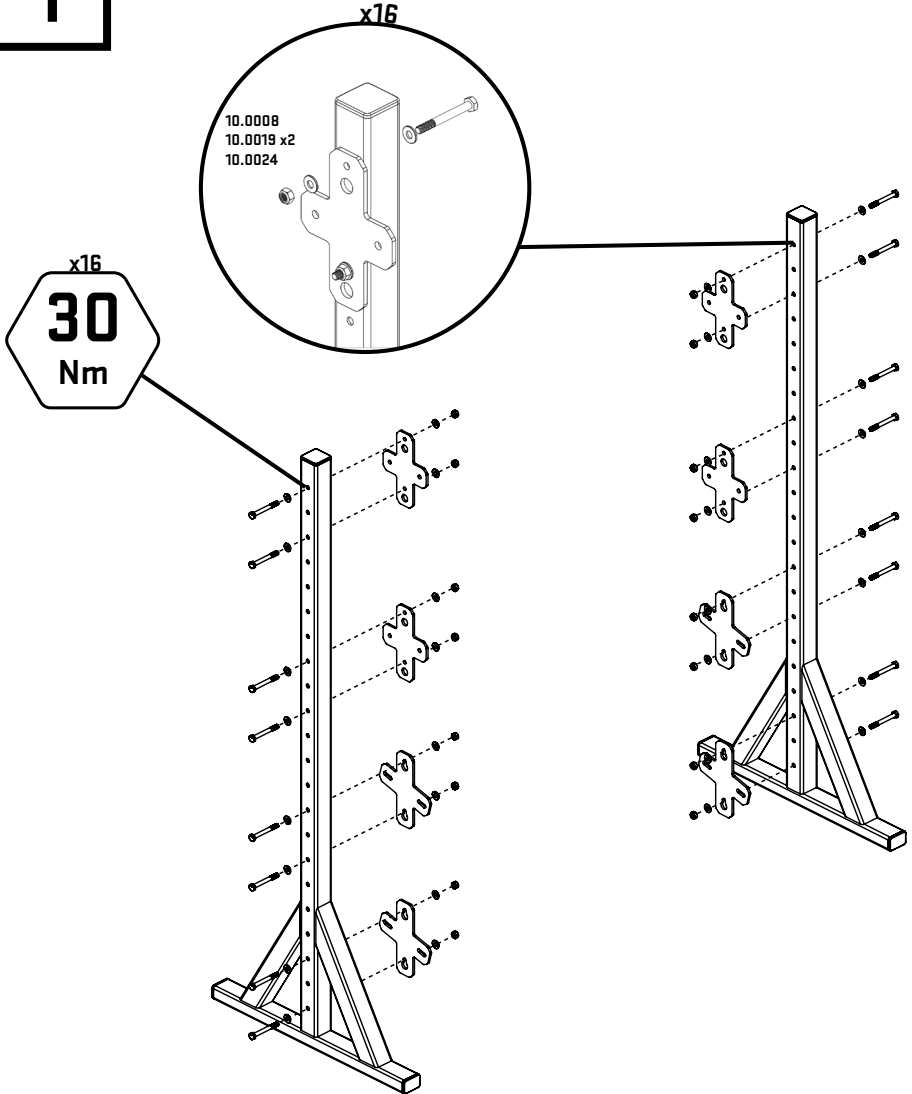

2

BOLT 10TY 1.8 BALL SHELF (21-0064-0A) 10TY 1.8 FLAT SHELF (21-0065-0B) AND 20TY 1.8 DUMBELL SHELF (21-0066-0B) BETWEEN 20TY BASECAMP UPRIGHT FRAME (21-0088-0A) WITH BOLTS ASSEMBLY AS SHOWN. ALL BOLTS FACING INWARDS. TIGHTEN ALL BOLTS TO SPECIFIED TORQUE. NOTE, DB AND KB SHELVE BOLTS ARE ON THE UNDERSIDE.

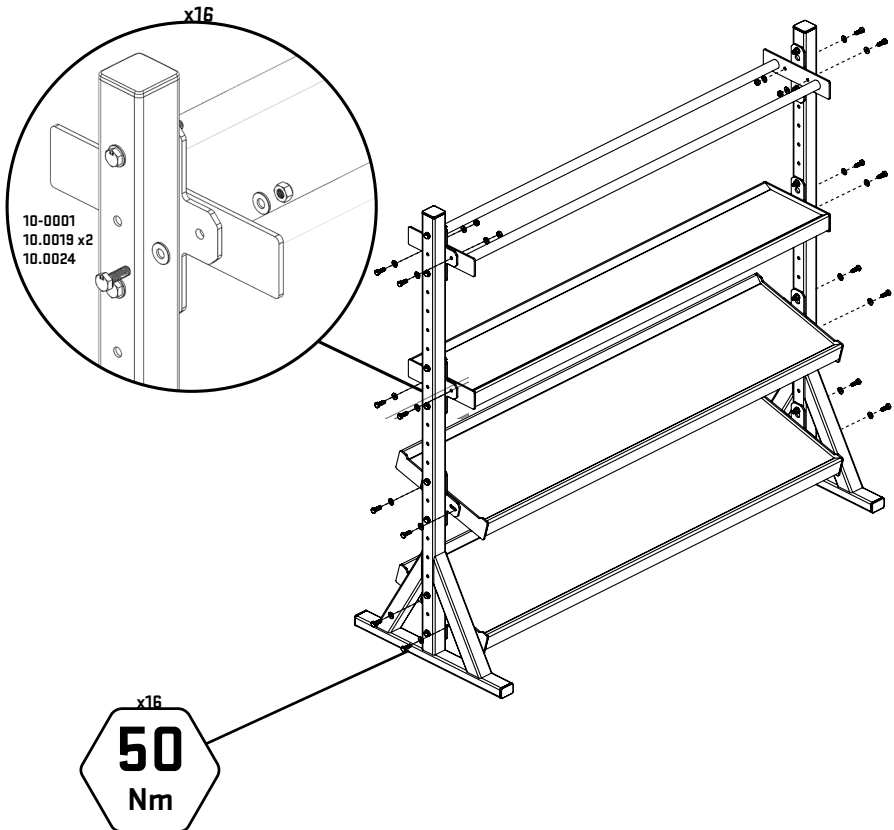

# 1:1 SCALE FASTENERS

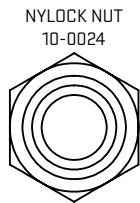
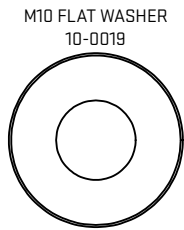
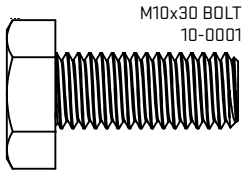
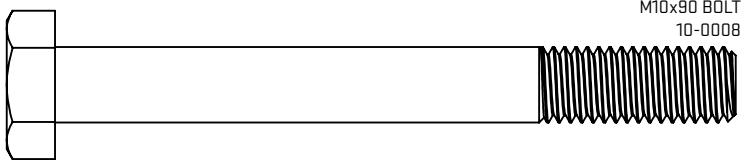

FOR TERMS AND CONDITIONS VISIT OUR WEBSITE AT  
[www.blkboxfitness.com/pages/terms-conditions](http://www.blkboxfitness.com/pages/terms-conditions)

GET IN TOUCH  
TEL: 028 9045 4123  
EMAIL: [info@blkboxfitness.com](mailto:info@blkboxfitness.com)

DISCOVER MORE AT:  
[www.blkboxfitness.com](http://www.blkboxfitness.com)

**THIS IS A BLANK PAGE**

**THIS IS A BLANK PAGE**