

BLK BOX BLACKOUT POWER RACK

21-0730

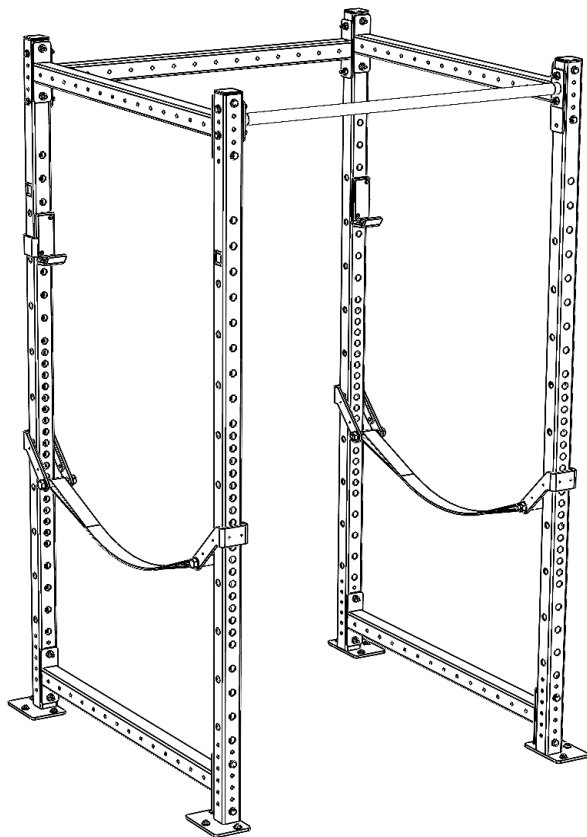

PRODUCT SPECIFICATION

PRODUCT WEIGHT	-	105kg
MAX USER WEIGHT	-	125kg
MAX USER	-	1
MAX TRAINING WEIGHT	-	300kg
DIMENSIONS	-	1320mmx1320mmx2208mm
SAFE WORKING ZONE	-	2000mmx2400mmx2700mm

OWNERS MANUAL & QUICK START GUIDE

NOTE: PLEASE READ ALL THE INSTRUCTIONS

CAREFULLY BEFORE ASSEMBLING THIS PRODUCT.

WARNING

SERIOUS OR FATAL INJURIES MAY OCCUR FROM INCORRECTLY ASSEMBLED EQUIPMENT. ALWAYS ENSURE BOLTS ARE TIGHTENED CORRECTLY AND ALL PARTS ARE LEVEL AND PLUMB. TO FURTHER REDUCE RISK OF INJURIES OR DEATH PLEASE USE OUR SUGGESTED TOOLS AND PERSONAL PROTECTIVE EQUIPMENT (PPE). WE SUGGEST THAT A MINIMUM OF THREE PEOPLE ARE INVOLVED IN THE ASSEMBLY OF THIS PRODUCT. EACH PERSON SHOULD BE EQUIPPED WITH SAFETY GLASSES, STEEL TOE CAP BOOTS AND EAR PLUGS.

PLEASE BE AWARE OF THIS SYMBOL AS AN INDICATION TO CHECK THAT A PART IS LEVEL OR PLUMB.



THIS SYMBOL IS AN INDICATION OF THE RECOMMENDED TORQUE EACH BOLT SHOULD BE TIGHTENED TO. THIS VALUE WILL BE DEPENDENT ON THE BOLT TYPE. PLEASE HAND TIGHTEN ALL BOLTS UNTIL YOU SEE THIS SYMBOL.



TOOLS REQUIRED



HAMMER DRILL



VACUUM



STEP LADDER

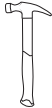

HAMMER



17MM SPANNER X2
13MM SPANNER



SPIRIT LEVEL



10MM MASONRY DRILL BIT

No.	Name	SKU	QTY
1	BLACKOUT POWER RACK UPRIGHT	21-0739	4
2	GOLIATH 1.2 SINGLE BAR CM	21-0015	1
3	1.2 BOX CM	21-0013	5
4	J-HOOK PAIR	16-0001	1
5	GOLIATH SAFETY STRAPS	16-0258	1
6	M10 SLEEVE ANCHOR BOLT	10-0031	12
7	M10X90 BOLT	10-0008	24
8	M10 FLAT WASHER	10-0019	60
9	M10 NYLOCK NUT	10-0024	24

PARTS & ATTACHMENTS

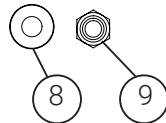
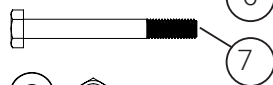
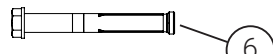
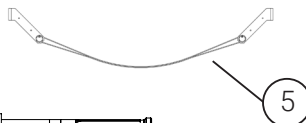
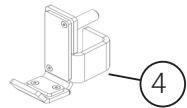
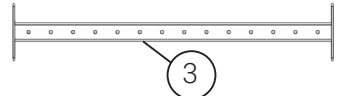
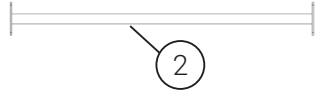
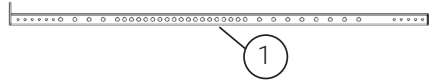

ASSEMBLY

1

BOLT 2QTY 1.2 BOX CM (21-0013) TO 2QTY POWER RACK UPRIGHT (21-0739) WITH BOLT ASSEMBLY AS SHOWN. REPEAT ABOVE STEP.

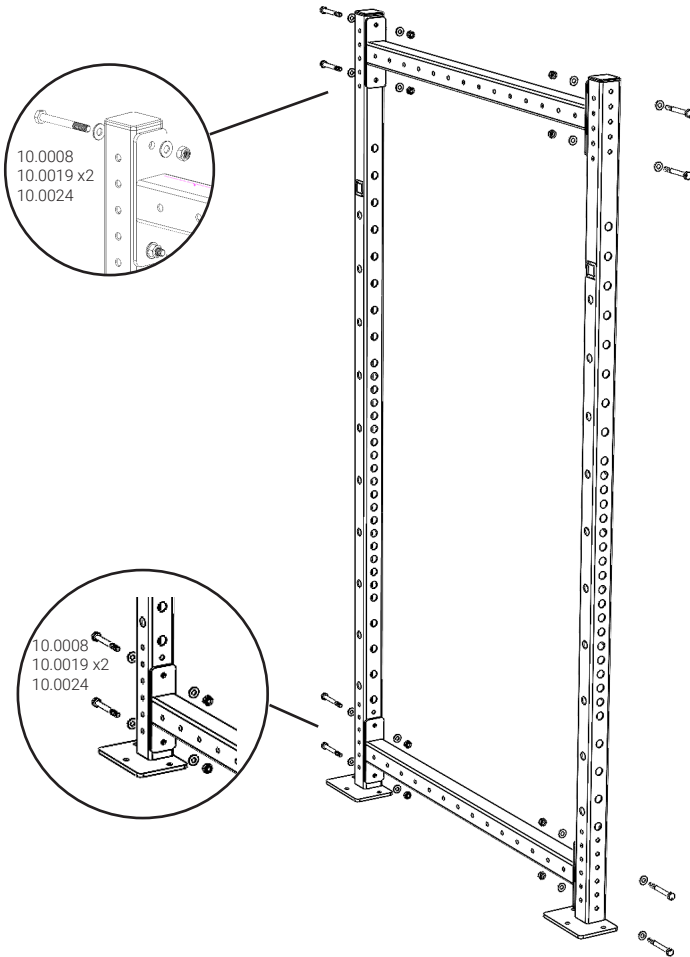

2

BOLT 1QTY 1.2 BOX CM (21-0013) TO 2QTY BACK UPRIGHT (21-0739) WITH BOLT ASSEMBLY AS SHOWN.
BOLT 1QTY 1.2 SINGLE BAR (21-0015) TO 2QTY FRONT UPRIGHT (21-0740) WITH BOLT ASSEMBY AS SHOWN.
ENSURE THAT ALL BLK BOX LOGOS ARE FACING OUTWARDS AND BOLTS ARE FACING INWARDS.

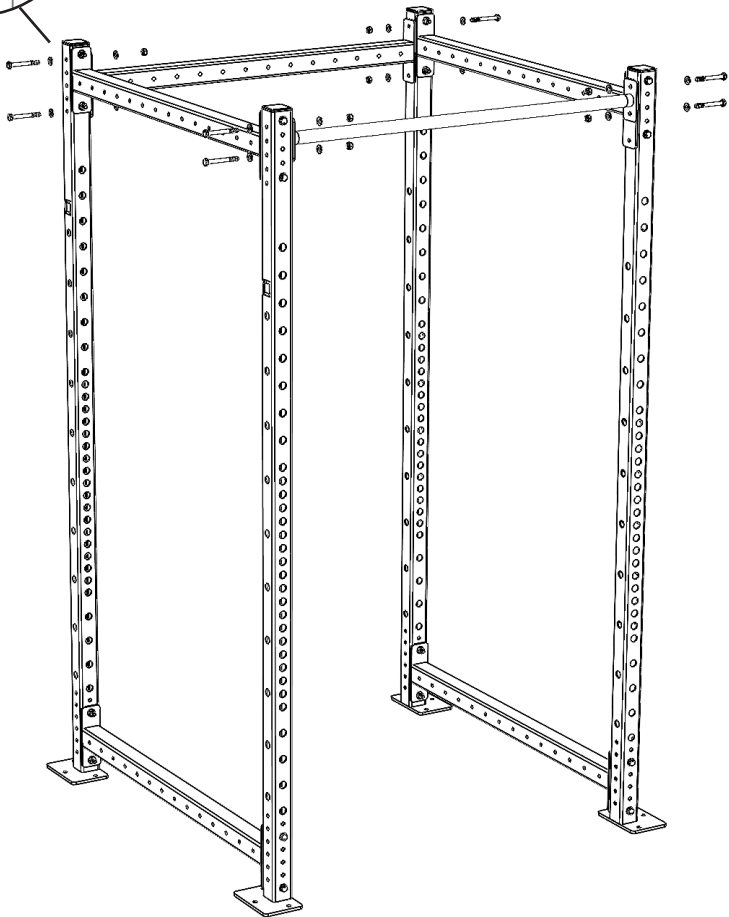
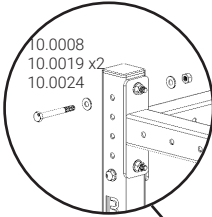

3

TIGHTEN ALL BOLT ASSEMBLIES TO THE SPECIFIED TORQUE.
ENSURE UPRIGHTS ARE PLUMB AND ALL SINGLE BARS ARE LEVEL.
DRILL AND SECURE UPRIGHTS AS SHOWN IN 4 STEP FLOOR MOUNTING GUIDE BELOW.

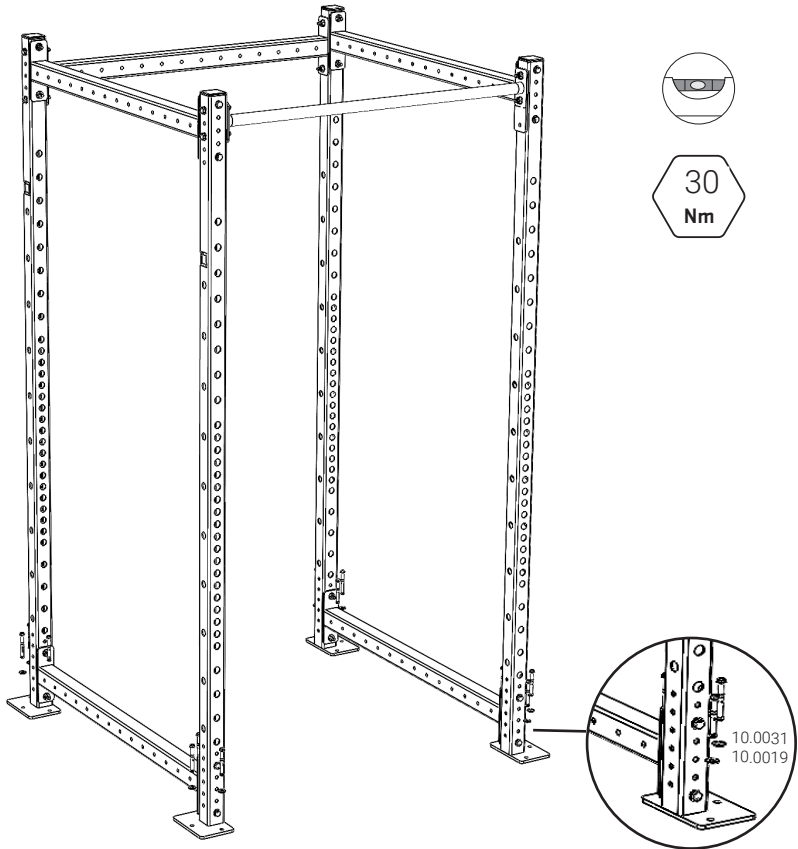

FLOOR MOUNTING

1. DRILL 10MM HOLE, 90MM DEEP USING PLATE AS A GUIDE.
2. VACUUM OUT THE DUST.
3. HAMMER SLEEVE ANCHOR INTO THE HOLE.
4. TIGHTEN SLEEVE ANCHOR TO SPECIFIED TORQUE USING 13MM SPANNER.

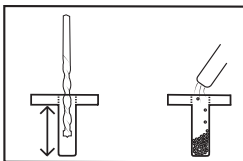

DRILL HOLE
90MM

VACUUM

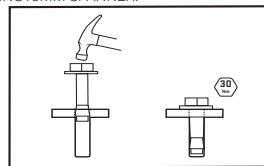

HAMMER IN
BOLT

TIGHTEN

1:1 SCALE FASTENERS

M10x80 SLEEVE ANCHOR
10-0031

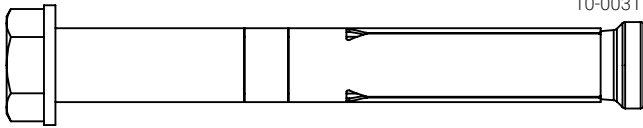

M10x90 BOLT
10-0008

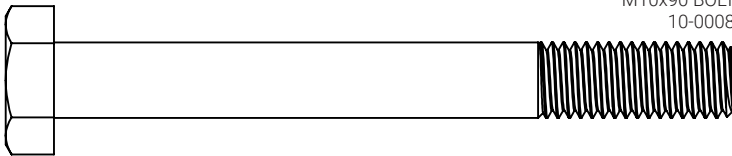

M10 FLAT WASHER
10-0019

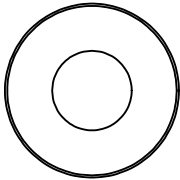

NYLOCK NUT
10-0024

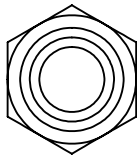

FOR TERMS AND CONDITIONS VISIT OUR WEBSITE AT:
www.blkboxfitness.com/pages/terms-conditions

GET IN TOUCH:
TEL: 028 9045 4123
EMAIL: info@blkboxfitness.com

DISCOVER MORE AT:
www.blkboxfitness.com