

HINGE  
PARTS LIST

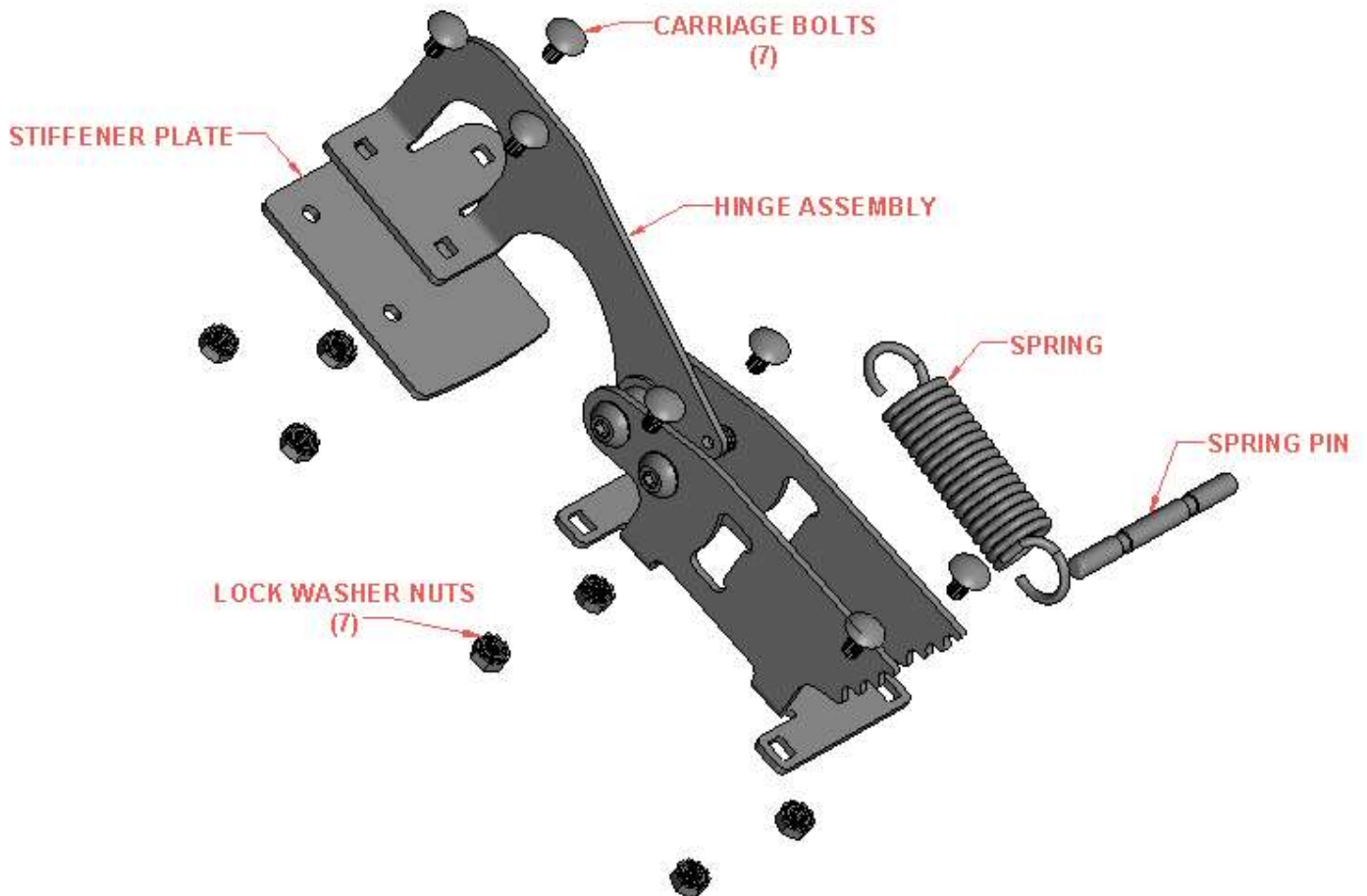

**TOOLS NEEDED:**

**PENCIL OR MARKER**

**HAND DRILL**

**5/16" DIA. DRILL BIT**

**7/16" WRENCH OR SOCKET**

## STEP 1

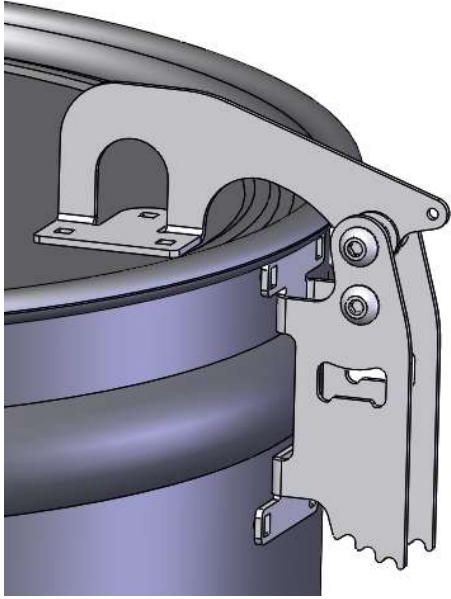

PLACE HINGE TIGHT AGAINST LID AND DRUM AND MARK (7) MOUNTING HOLES. REMOVE HINGE AND DRILL 5/16" DIA. HOLES.

## STEP 2

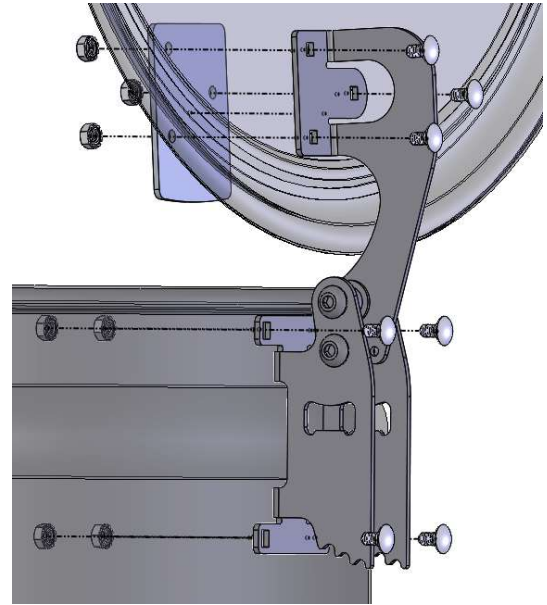

ASSEMBLE LID FIRST WITH (3) CARRIAGE BOLTS, STIFFENER PLATE AND (3) LOCK WASHER NUTS THEN MOUNT HINGE TO DRUM WITH (4) BOLTS AND NUTS.

## STEP 3

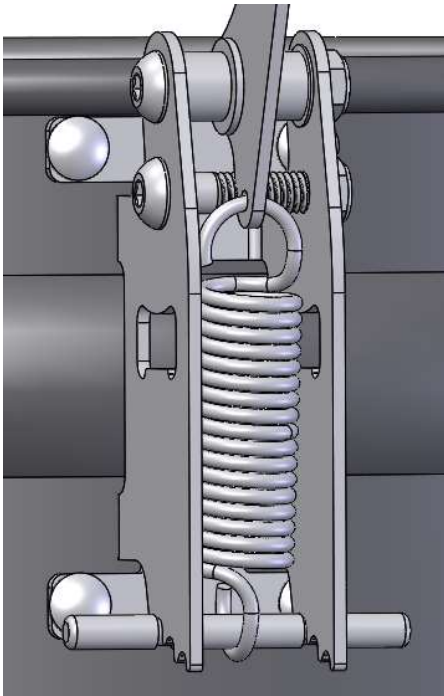

ASSEMBLE SPRING LOOP THRU HOLE ON LID BRACKET AND OPEN LID. WITH THE LID OPEN RUN SPRING PIN THRU BOTTOM LOOP OF SPRING AND PULL DOWN ON PIN AND PLACE INTO NOTCHES OF DRUM BRACKET.

## STEP 4

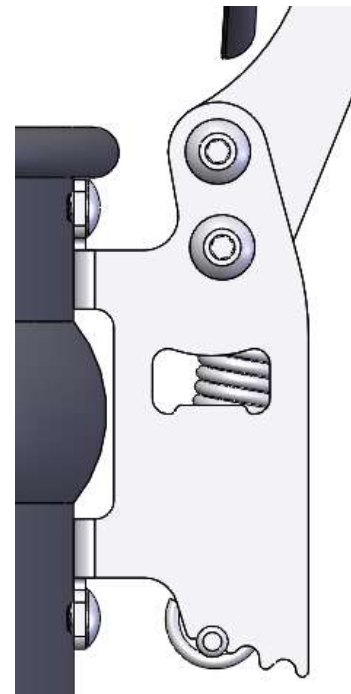

THERE ARE 3 NOTCHES ON DRUM BRACKET FOR SPRING ADJUSTMENT. MOVING THE SPRING PIN INTO THE NOTCHES FARTHER FROM THE DRUM INCREASES THE SPRING FORCE. ALWAYS ADJUST THE SPRING PIN WITH THE LID IN FULL OPEN POSITION.