

TRX-EL TORO

TRX-30CA-AC-FS

TRX-40CA-AC-FS

TRX-50CA-AC-FS

TRX-30CA-FS

TRX-40CA-FS

TRX-50CA-FS

Product Manual

CONGRATULATIONS! Your new TRX Off-Road lightbar has been engineered to provide you powerful, reliable service for many years to come. In this instruction sheet, you will not only find technical information, but care instructions as well, for maintaining the original performance of your new TOMAR Rugged Extreme (TRX) Off-Road Lightbar.

Thank you for your purchase!

Wiring

Main Power Wires

Wiring the TRX lightbar into the vehicles electrical system does not require the use of relays. The power and ground leads are connected directly to the 12Vdc to 24Vdc supply voltage and are always hot.

- Red to +Vdc
- Black to -Vdc

Control Cable

Activating the Lightbar is done by applying +Vdc to one or more of the lightbar control wires. The control wires consume only a few milliamps of current and can be used with virtually any on/off switch. There are five control wires in the Control Cable plus one +Vdc supply feed.

The control wires are color coded and control the functions shown below. Keep in mind that not all lightbars will be configured in such a way that all control wires are used.

- Orange - Group 1 lamps
- Blue - Second Color lamps
- Brown/White - S.O.S. or warning pattern
- Brown wire - Running lamp
- Green wire - Dimming of all lamps
- Red/White - +Vdc

Orange Wire – On single color single beam pattern bars the orange wire will turn on the entire bar. If the lamps in the lightbar are two beam patterns, half spot and half flood for example, the orange wire will turn on just the spot lamps.

Blue Wire – If all the lamps in the lightbar have the same beam pattern, the blue wire will have no effect on the lightbar and can be ignored. If the lamps in the lightbar are two different beam patterns, some spot and some flood for example, the blue wire will turn on just the flood lamps. If you have a multi-beam pattern lightbar and just want on/off functionality simply wire both the orange and blue wires to a single switch.

If the lightbar is configured as a COLOR/white combination bar, the orange wire will activate the white lights and the blue wire will activate the COLOR lights. In case both the orange and blue wires are activated at the same time the COLOR lights will activate and the white lights will shut off. The COLOR lights can be amber, red, blue or green.

Brown Wire - If the lightbar is configured as a COLOR/white combination bar, and the COLOR lights are activated, the Brown wire will force one lamp to remain white to serve as the required front facing white light.

Brown/White Wire –Activates the S.O.S. or warning patterns. See below for available flash patterns.

Green Wire – In all lightbars the green wire activates a low intensity or dim setting.

Red/White Wire – In all lightbars the red/white wire is a +Vdc feed that can be used to power one or more switches.

COLOR/White Combo Available Flash Patterns and Rates:

Patterns

- 1) Off
- 2) COLOR Combination (Patterns 5,4,6 Repeat) Default Pattern
- 3) White S.O.S.
- 4) COLOR Alternating
- 5) COLOR Random
- 6) COLOR Sweep

Rates

- 1) Single – Default Rate
- 2) Double
- 3) Neobe
- 4) Scroll

Note: The White S.O.S. Flash Pattern has a fixed Flash Rate (5 WPM, not listed above).

Changing Patterns and Rates:

To Enter Programming Mode:

- 1) All Inputs Open, apply Power and Ground to the lightbar (red and black wires).
- 2) Connect Green wire to +Vdc.
- 3) Wait at least one second, Double Tap the Brown wire to +Vdc. All the lamps should flash 3 times to indicate you've entered Programming Mode.

Note: The Double Tap of the Brown wire **must** occur within 4 seconds of connecting the Green wire to +Vdc, otherwise the lightbar will NOT enter Program Mode and will operate normally.

To change the Flash Pattern:

- 1) Brown/White wire must be Open, i.e. not connected to +Vdc.
- 2) Tap the Brown wire to +Vdc to step forward through the patterns.
- 3) Tap the Brown wire to +Vdc twice to step backward through the patterns.
- 4) Touch and Hold the Brown wire to +Vdc for 3 seconds to reset the pattern to the default flash pattern.

To change the Flash Rate:

- 1) Connect the Brown/White wire to +Vdc.
- 2) Tap the Brown wire to +Vdc to step forward through the flash rates.
- 3) Tap the Brown wire to +Vdc twice to step backward through the flash rates.

4) Touch and Hold the Brown wire to +Vdc for 3 seconds to reset the pattern to the default flash rate.

Wire Runs

The table below lists the maximum recommended wire run for the power and ground cables in feet. The control cable can be the same length as the power cables but 20-gauge wire is sufficient for all distances.

Part Number	Lamps	WIRE GAUGE					
		18	16	14	12	10	8
TRX-03	1	89	142	225	361	575	914
TRX-06	1	51	81	129	206	328	522
TRX-10	2	25	40	64	103	164	261
TRX-15	3		27	42	68	108	174
TRX-20	4		20	31	50	82	130
TRX-25	5		16	25	41	65	104
TRX-30	6			21	34	54	86
TRX-35	7			18	29	46	74
TRX-40	8				25	41	65
TRX-45	9				22	36	57
TRX-50	10					32	52
TRX-60	12					27	43

Common Switch Wiring Configuration

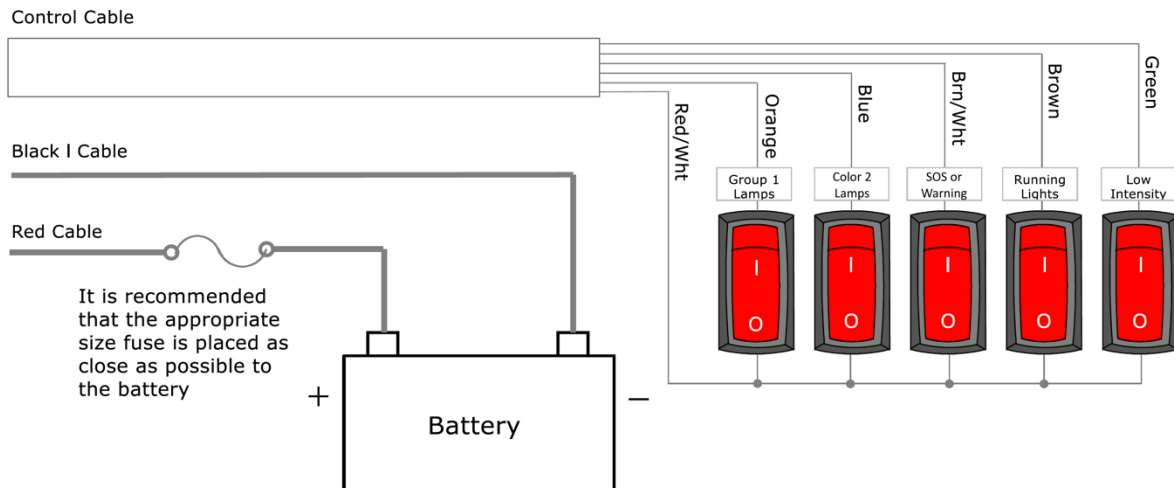

Mounting

The TRX-EI Toro will come with the mounting bolts already installed on the bottom of the lightbars.

- 1) Remove the bumper

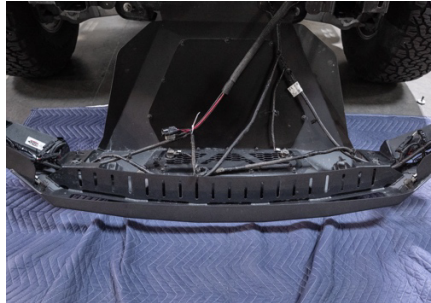

- 2) Measure and space the bolts along bumper, then add washer and nut and tighten



- 3) Add jam nut and washer for height adjustment



- 4) Loosen hex screws on hinges to allow bar to conform to bumper contour

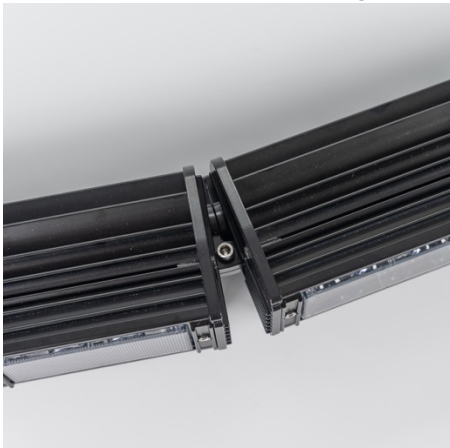

5) Mount on bumper, aligning mounting bolts to bumper slots



6) Turn jam nut to adjust height



7) Add washer and lock nut to bolt and tighten to fasten lightbar into place



8) Tighten hex screws on hinges to set the angle

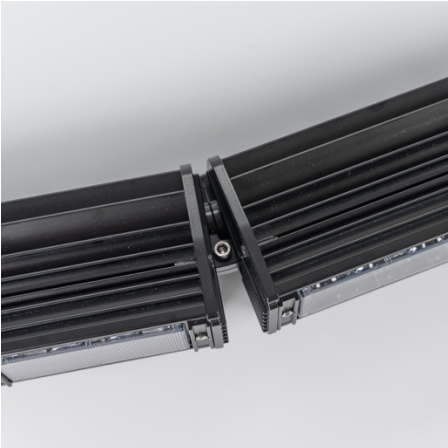

9) Verify lightbar height, if adjustments are needed repeat step 5



Recommended Fuse/Breaker Sizing

Part Number	Lamps	Amp draw @13.8Vdc	Fuse/Breaker Size (A)
TRX-03	1	1.3	3
TRX-06	1	2.1	5
TRX-10	2	4.2	10
TRX-15	3	6.3	12
TRX-20	4	8.4	15
TRX-25	5	10.5	20
TRX-30	6	12.6	25
TRX-35	7	14.7	30
TRX-40	8	16.8	35
TRX-45	9	18.9	40
TRX-50	10	21.0	45
TRX-60	12	25.2	50

Replacing a lamp module

All TRX lamp modules are interchangeable and can be used in any position on the lightbar. This offers the flexibility to configure a lightbar for any mission with perfect balance of flood, spot or dual color modules.

With this modular design the replacement of a TRX Lamp couldn't be easier. Each module is hermetically sealed so replacement will not compromise the watertight integrity of the lightbar or void the warranty.

To replace a lamp module simply remove the two lamp clips using a 9/64" hex tool. Unplug the lamp from the waterproof connector, plug the new lamp in and reattach the lamp clips.

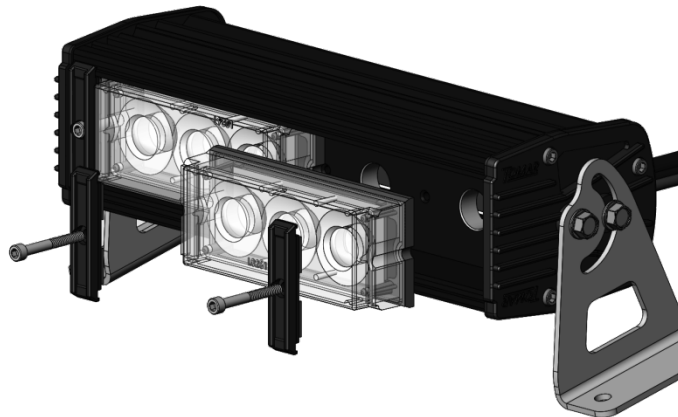

Maintenance

The best cleaning method is to gently wash the lightbar with a solution of mild soap and lukewarm water, using a soft cloth or sponge to loosen any dirt or grime. Thoroughly rinse with clean water to remove any cleaner residue and dry the surface with a soft cloth to prevent water spotting.

If using a high-pressure water cleaner and/or a steam cleaner the pressure should not exceed 1,450psi. The use of additives to the water and/or steam should also be avoided.

Important Considerations for Lexan lenses:

- Never use abrasive or highly alkaline cleaners.
- Never use aromatic or halogenated solvents like toluene, benzene, gasoline, acetone or carbon tetrachloride.
- Contact with harsh solvents such as methyl ethyl ketone (MEK) or hydrochloric acid can result in surface degradation and possible crazing.
- Never scrub lenses with brushes, steel wool or other abrasive materials.