

CNC Vacuum Part Grabber Spec Sheet

CNC Vacuum Part Grabber (Through Air)

Vacuum Part Grabber Gripper Specifications

	Imperial	Metric
Vacuum Type	Venturi Generated	Venturi Generated
Suction Cup Port Size	1/8" NPT	1/8 NPT
Max Vacuum Achievable	12 PSI	0.82 Bar
Maximum Flow Rate	0.8 CFM	22.0 L/min
Maximum Part Weight	22 lbs.	10 kg
Overall Dimensions (w/o Cup)	3.813" x 2.250" x 1.250"	96.85mm x 57.15mm x 31.75mm
Input Pressure Range	75-140 psi	5.20 – 9.65 Bar

Required Machine Options

	Required?	Notes
Through Spindle Air	Yes	Can be added using Instant Solenoid Kit from Gimbel Automation

Gimbel Automation Vacuum Part Grabber Suction

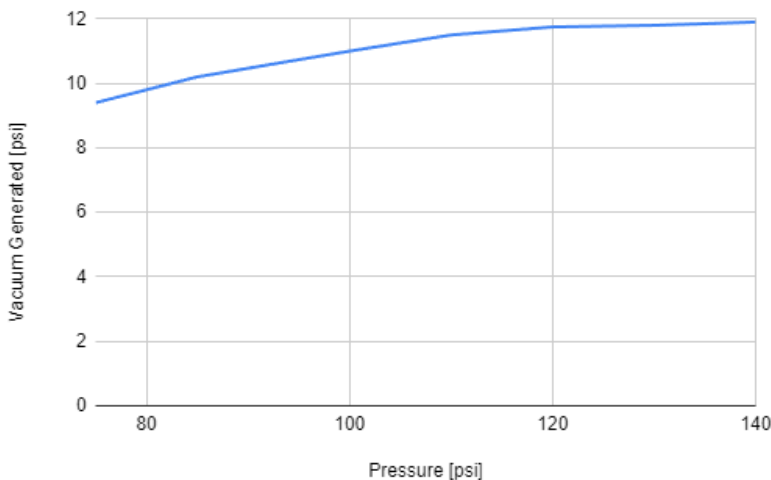

Vacuum Part Grabber Construction

	Material
Body	7075 Aluminum
Venturi Generator	Stainless Steel
Cap	7075 Aluminum
Gasket	Rubber

These specifications and data may vary slightly from lot to lot or as Gimbel Automation changes or improves designs. This data is for guidance only, and Gimbel Automation makes no representations about the extent to which this data is accurate. All data was experimentally corrected from on-hand equipment. Depending on the type of available equipment and the type of automation machinery, testing methodology may vary. The information herein should not be used to determine design or specification limits – you should always conduct your own testing to verify that the equipment being used fits the needs to safely satisfy your application. Gimbel Group, Gimbel Automation, and any subsidiaries or affiliates thereof make no warranties of any kind, express or implied, including but not limited to the fitness of components for a particular use or specification, merchantability, or mechanical properties.

CNC Vacuum Part Grabber Layout Drawing

CNC Vacuum Part Grabber (Through Air)

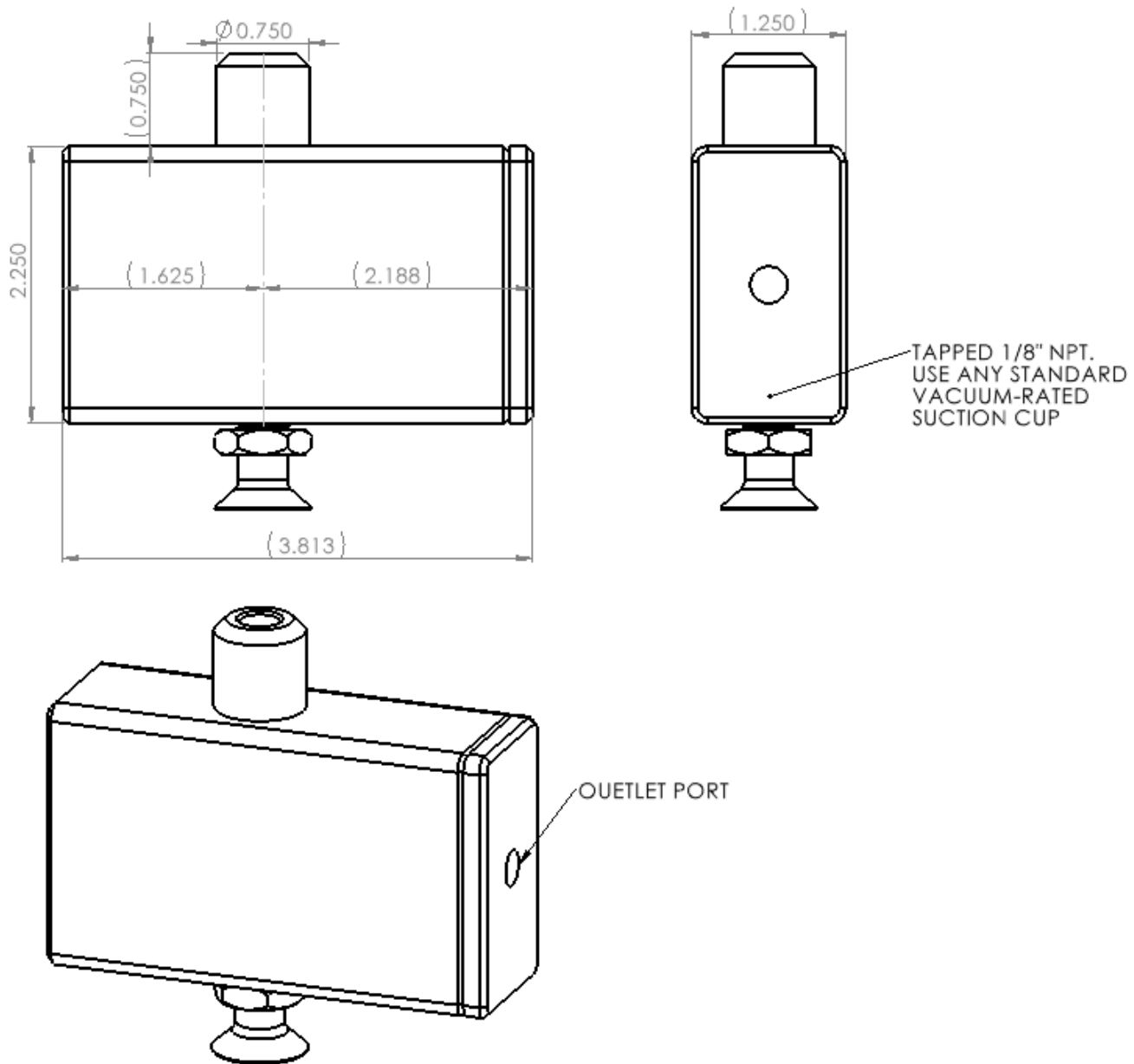

These specifications and data may vary slightly from lot to lot or as Gimbel Automation changes or improves designs. This data is for guidance only, and Gimbel Automation makes no representations about the extent to which this data is accurate. All data was experimentally corrected from on-hand equipment. Depending on the type of available equipment and the type of automation machinery, testing methodology may vary. The information herein should not be used to determine design or specification limits – you should always conduct your own testing to verify that the equipment being used fits the needs to safely satisfy your application. Gimbel Group, Gimbel Automation, and any subsidiaries or affiliates thereof make no warranties of any kind, express or implied, including but not limited to the fitness of components for a particular use or specification, merchantability, or mechanical properties