

# 75mm Air Vise Spec Sheet

Self-Centering Air Vise (75mm)

## Spindle Gripper Specifications

	Imperial	Metric
<b>Vise Actuation</b>	Pneumatic	Pneumatic
<b>Vise Type</b>	Self-Centering	Self-Centering
<b>Jaw Width</b>	2.953"	75mm
<b>Part Size Range (Inner Clamp)</b>	0.33 – 0.185"	8.4 – 47.0mm
<b>Part Size Range (Outer Clamp)</b>	3.42 – 6.00"	87.0 – 152.0mm
<b>Pressure Range</b>	0-140 psi	0 – 9.65 Bar
<b>Repeatability</b>	+/- 0.0008"	+/- 0.02mm
<b>No Air Clamp Force</b>	900lbs	4000N
<b>Overall Dimensions (w/o Jaws)</b>	4.921" x 4.921" x 3.189"	125mm x 125mm x 81mm

## Required Machine Options

	Required?	Notes
<b>Programmable Air (Haas)</b>	Not Required	Slightly Faster Install
<b>Gimbel UMC Rotary Union</b>	Required for UMC's Only	UMC's Only
<b>Air Vise Ready (Haas)</b>	Alternative to Gimbel UMC Union	UMC's Only
<b>Relays Available on Machine</b>	At Least One Required	One relay and M-code required

Gimbel Automation 75mm Air Vise Force Graph

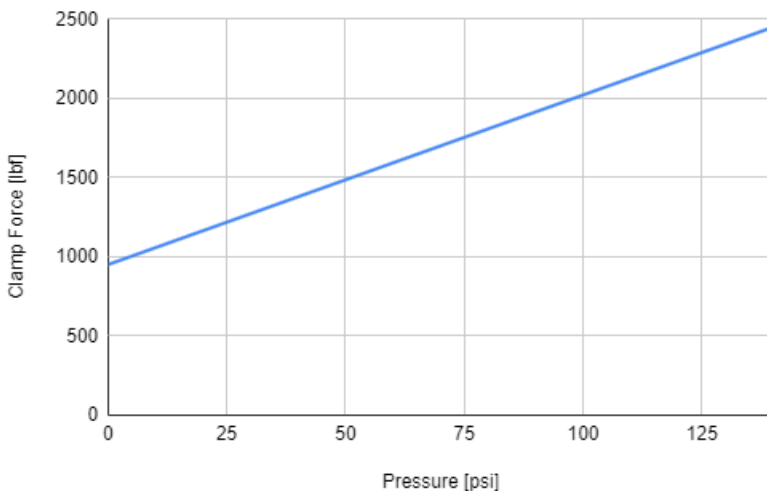

## Spindle Gripper Construction

	Material
<b>Vise Body</b>	Blued Steel
<b>Vise Slides</b>	Hardened Steel
<b>Inner Spacer</b>	Anodized Aluminum
<b>Hard Jaws</b>	Hardened Steel
<b>Soft Jaws</b>	6061 Aluminum

These specifications and data may vary slightly from lot to lot or as Gimbel Automation changes or improves designs. This data is for guidance only, and Gimbel Automation makes no representations about the extent to which this data is accurate. All data was experimentally corrected from on-hand equipment. Depending on the type of available equipment and the type of automation machinery, testing methodology may vary. The information herein should not be used to determine design or specification limits – you should always conduct your own testing to verify that the equipment being used fits the needs to safely satisfy your application. Gimbel Group, Gimbel Automation, and any subsidiaries or affiliates thereof make no warranties of any kind, express or implied, including but not limited to the fitness of components for a particular use or specification, merchantability, or mechanical properties.

# 75mm Air Vise Layout Drawing

Self-Centering Air Vise (75mm)

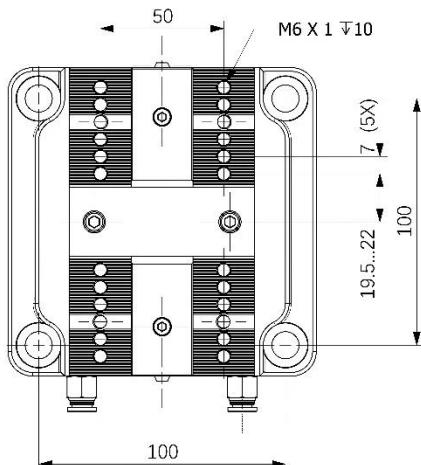
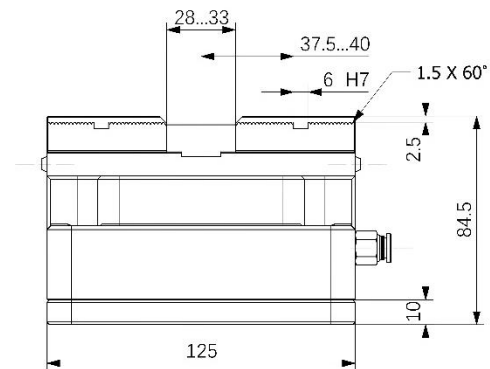
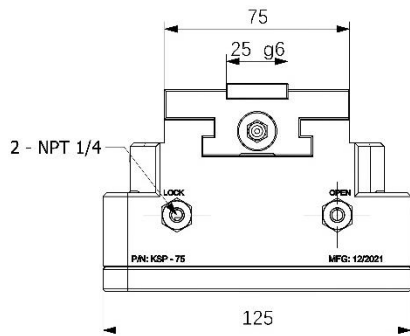
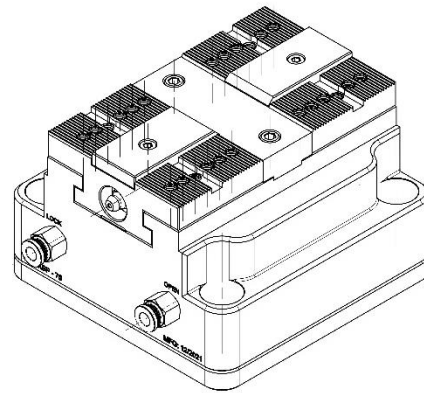
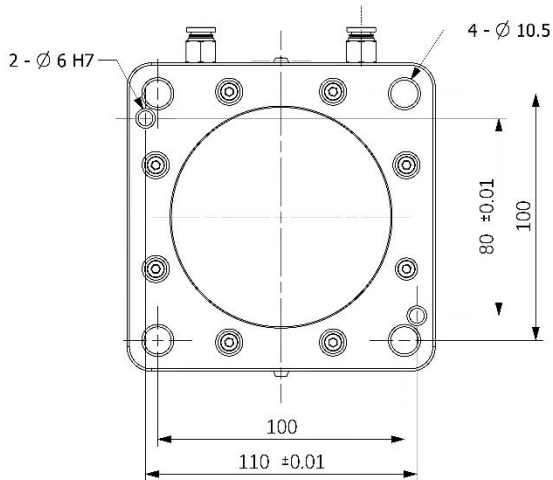

These specifications and data may vary slightly from lot to lot or as Gimbel Automation changes or improves designs. This data is for guidance only, and Gimbel Automation makes no representations about the extent to which this data is accurate. All data was experimentally corrected from on-hand equipment. Depending on the type of available equipment and the type of automation machinery, testing methodology may vary. The information herein should not be used to determine design or specification limits – you should always conduct your own testing to verify that the equipment being used fits the needs to safely satisfy your application. Gimbel Group, Gimbel Automation, and any subsidiaries or affiliates thereof make no warranties of any kind, express or implied, including but not limited to the fitness of components for a particular use or specification, merchantability, or mechanical properties.

# 75mm Hard Jaw Layout Drawing

Self-Centering Air Vise (75mm)

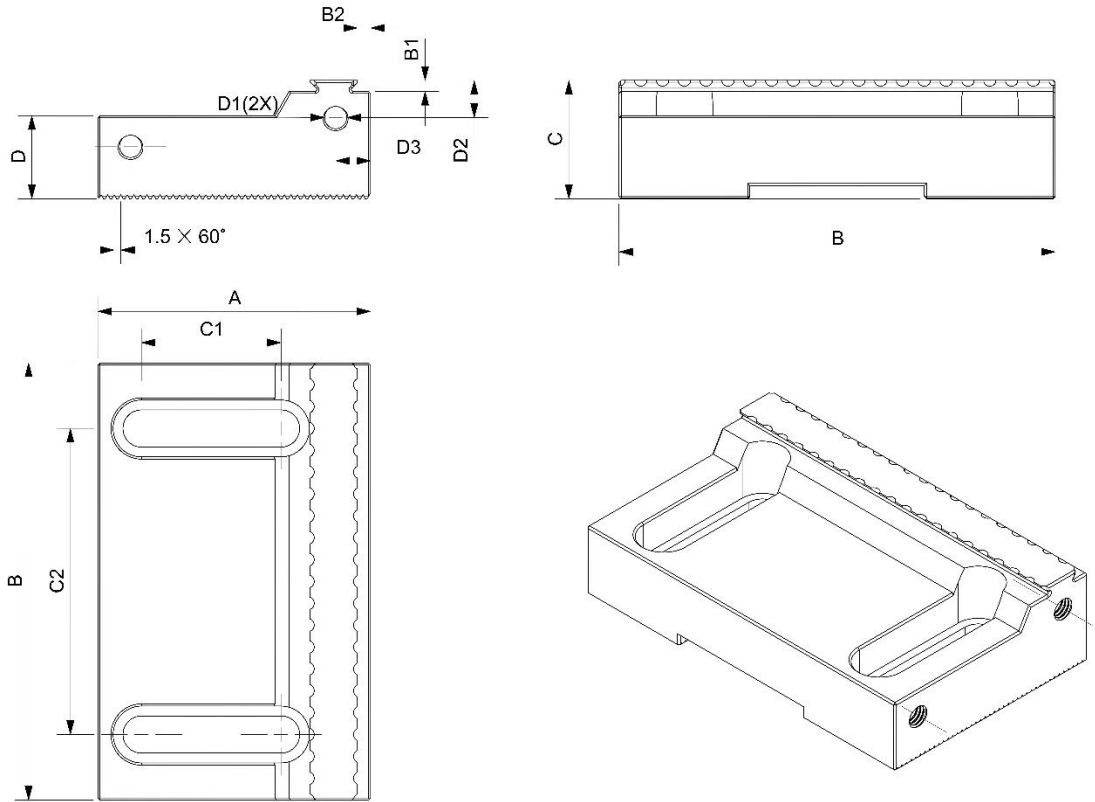

## 75mm Hard Jaw

<b>A</b>	60.0 mm
<b>B</b>	75.0 mm
<b>B1</b>	2.5 mm
<b>B2</b>	3.0 mm
<b>C1</b>	27.5 mm
<b>C2</b>	50.0 mm
<b>D1</b>	M6 Tapped
<b>D2</b>	9.5 mm
<b>D3</b>	7.0 mm

These specifications and data may vary slightly from lot to lot or as Gimbel Automation changes or improves designs. This data is for guidance only, and Gimbel Automation makes no representations about the extent to which this data is accurate. All data was experimentally corrected from on-hand equipment. Depending on the type of available equipment and the type of automation machinery, testing methodology may vary. The information herein should not be used to determine design or specification limits – you should always conduct your own testing to verify that the equipment being used fits the needs to safely satisfy your application. Gimbel Group, Gimbel Automation, and any subsidiaries or affiliates thereof make no warranties of any kind, express or implied, including but not limited to the fitness of components for a particular use or specification, merchantability, or mechanical properties.