



Anytime Backup & New Front Camera Install 2014 – 2019 & 2020+

Full Install Video QR Code

Scan the QR code below to access our install video or visit our YouTube Channel here:

<https://youtu.be/QzD5iTx1mA>



An Anytime Backup Camera Product



Step 1 – Radio Removal: Remove the radio unit from your vehicle. Detailed instructions on how to remove your radio are within our video mentioned above.

Step 2A – Harness Connections 2014 – 2019 Models: After removing the radio, locate the connectors on the rear and prepare to connect the corresponding Anytime Backup Camera harnesses. While our 14-19 kits are made to fit most 2014-2019 Toyotas, they may work with certain models outside this year range.

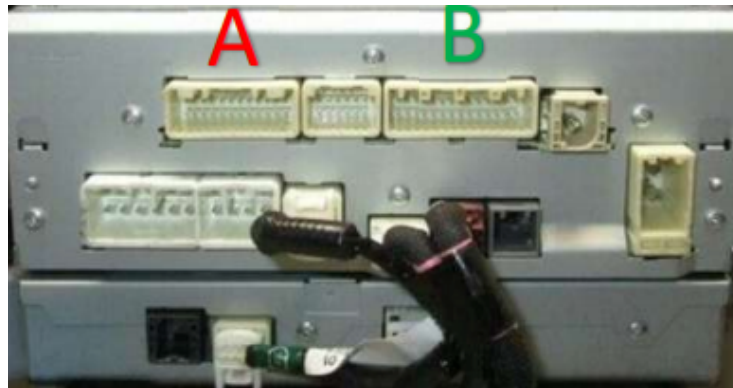

Figure 1 - Rear of 2014 - 2019 Radio

Remove the factory harness from **Connector A** and plug the '**Video Harness**'. Plug the factory harness into the Anytime Backup Camera **Video Harness**.



Figure 2 - Video Harness (Connector A)

Remove the factory harness from **Connector B** and plug the '**Override Harness**'. Plug the factory harness into the Anytime Backup Camera **Override Harness**.



Figure 3 - Override Harness (Connector B)

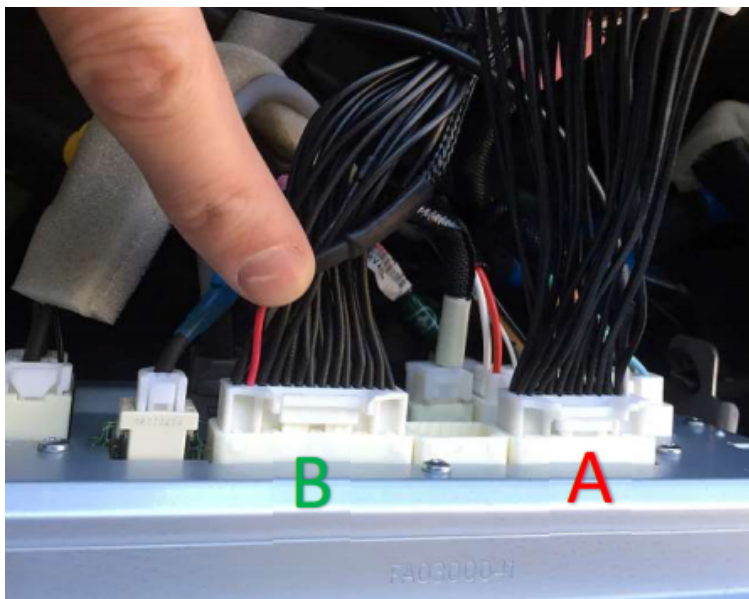

Figure 4 - Override & Video Harnesses Installed (View of radio from top down)

Step 2B – Harness Connections 2020+ Models (2020 Kits): After removing the factory radio, locate the connectors on the rear and prepare to connect the corresponding Anytime Backup Camera harnesses. While our 2020 kits are made to fit most 2020+ Toyotas, they may work with certain models outside this year range

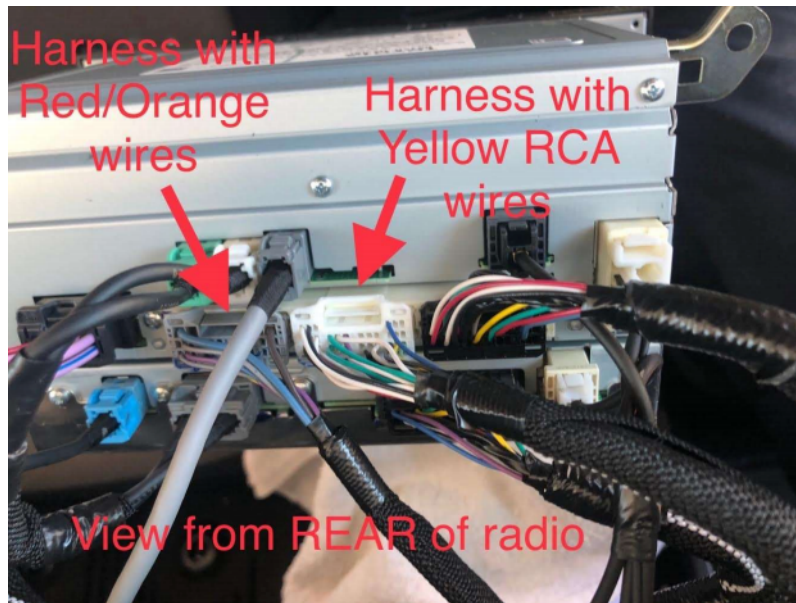

Figure 5 - Rear of 2020+ Radio

The photo above shows the view of a '2020' Style radio from the rear. What you see on the left of this photo will be on the PASSENGER SIDE of the vehicle when the unit is installed.

Step 3 – Switching Relay Connection: Find the Switching Relay which came in your kit. This relay may have come bundled together with the Video Harness. The Switching Relay has two wires for power, Green (Positive) and Black (Negative/Ground), and three video connections. There are two Female Yellow RCA Connections and one Male Yellow RCA connection. One of the two Female connectors will have a black marking on it which indicates the REAR Camera input.



Figure 6 - Switching Relay (Two Female RCA, One Male RCA Yellow Plug)

Step 3.1 – Switching Relay Video (RCA) Connections: Follow the procedure bulleted here and shown in Figure 7 below:

- Connect the Yellow RCA plugs on the Switching Relay to the Video Harness
 - Connect the MALE on the SWITCHING RELAY to the FEMALE on the VIDEO HANRESS



- Connect the MALE on the VIDEO HARNESS to the FEMALE on the SWITCHING RELAY

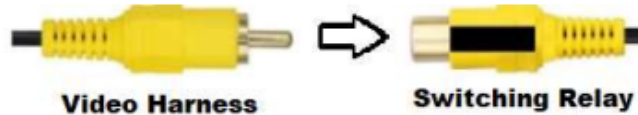

Once completed you will have one free FEMALE RCA connector on the SWITCHING RELAY. This is to be used for the Front Camera input.

Continue to next page ...

RCA connections outlined in step 3.1

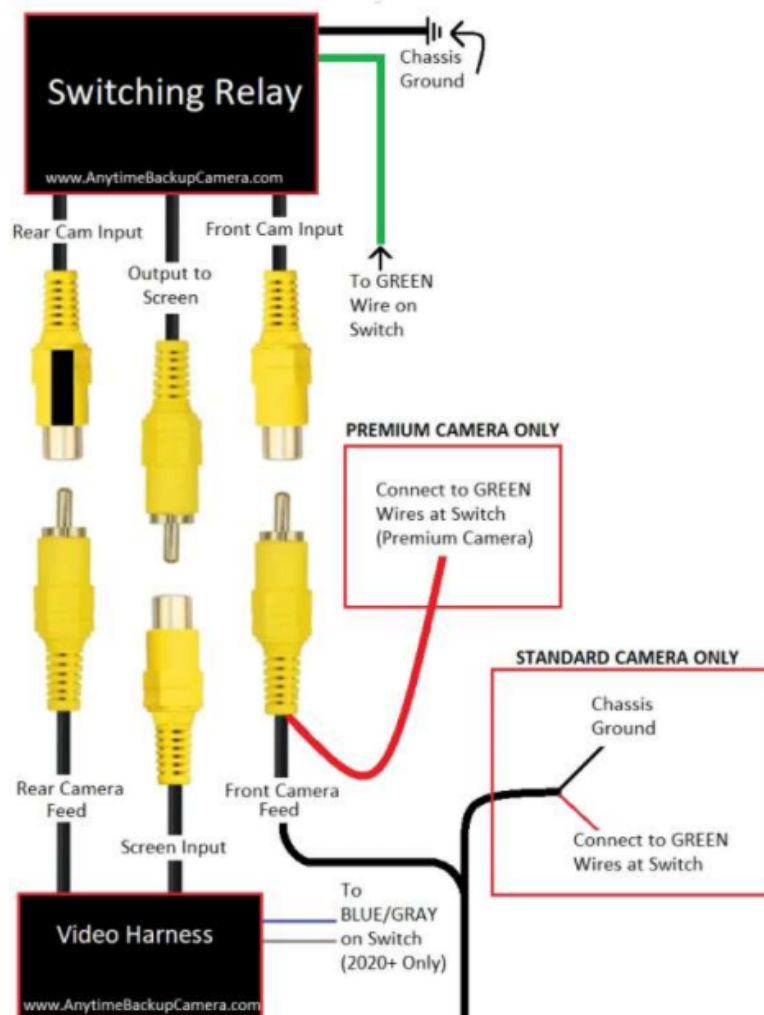

Figure 7 - Switching Relay/Video Harness Connection Diagram

Step 3.2 – Switching Relay Power Connections: The Switching Relay requires a 12v Connection (Green Wire) and Ground Connection (Black Wire) to operate.

As with all black wires in the kit, the Black wire on the switching relay needs to be connected to a good ground in the vehicle. All grounds can be tied together at one point if wanted. Grounding to the side of the radio is good spot to use:

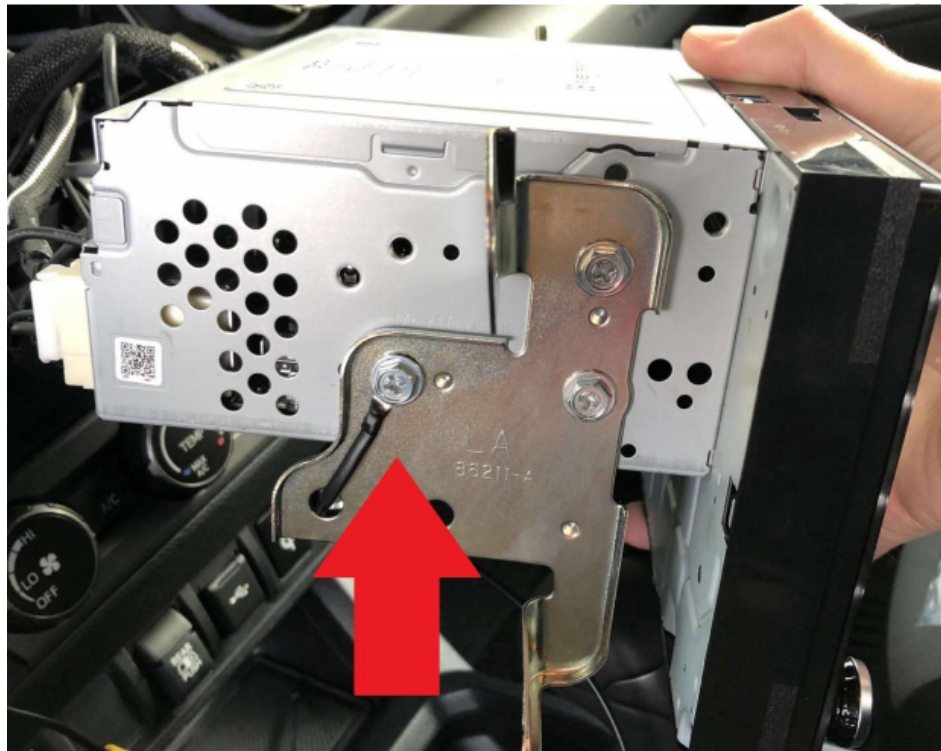

Figure 8 - Grounding Point for Black Wire

For the 12v Power Connection the GREEN Wire from the Switching Relay will connect to the GREEN wire from the switch. These two green wires will also be connected to the RED power wire from the Front Camera. All Connections are outlined in the Component Diagram on the last page of this document.

Step 4 – Wiring the Switch: The Front/Rear switch has six wires which need to be connected to the appropriate spots. The bullets below outline the function of each wire:

- Red - 12v Input
 - The Red wire from the Override Harness will connect here and supply the system with 12v power
- Orange - REAR 12v Output
 - This wire will connect to the Orange wire on the Override Harness. When the switch is pressed to REAR or FRONT there should be 12v at this wire.
- Green - FRONT 12v Output



- This wire will connect to the Green wire on the Switching Relay and the Red wire from the Front Camera. When the switch is pressed to Front there should be 12v at this wire.

- Black - Ground
 - This wire will need to be connected to a good chassis ground point.

- Blue - Backlight 12v Input
 - The switch has a fully controllable backlight circuit. On 2020+ models you will connect this wire to the Blue wire on the Video Harness. For pre-2020 models this wire should be tapped into the positive illumination wire in the vehicle (instructions vary by model/trim).
 - To illuminate the backlight without connecting to the vehicle illumination circuit this Blue wire can be connected to the Red wire on the switch.

- Gray - Backlight Ground
 - The switch has a fully controllable backlight circuit. On 2020+ models you will connect this wire to the Gray wire on the Video Harness. For pre-2020 models this wire should be tapped into the negative illumination wire in the vehicle (instructions vary by model/trim).
 - To illuminate the backlight without connecting to the vehicle illumination circuit this Gray wire can be connected to a chassis ground.

The diagram on the following page outlines all switch connections.

Step 4.1 – Front/Rear Switch Diagram

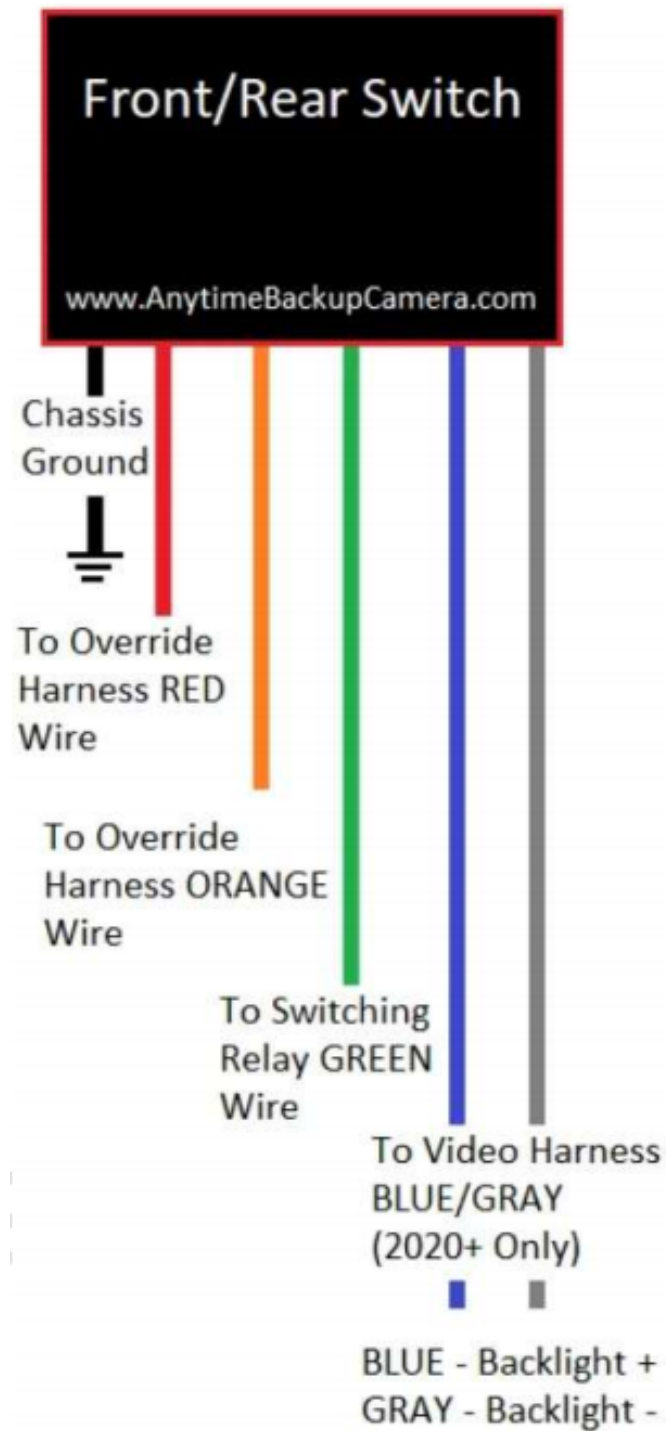

Figure 9 - Front/Rear Switch Wire Descriptions



Step 5A – Identifying Your Camera

The Premium Camera is offered for a higher quality camera output. This camera is made by Natika and can be mounted either Vertically or Horizontally which will give you more flexibility when finding a place to mount your camera. The camera also comes with three wedges which will allow you to change the viewing angle of the camera, again giving you more control of your installation.

Vertical Mount



Horizontal Mount



The camera will have three wire loops on the camera wire, Green, White, and Purple. Cutting the wires will do the following:

- Green - Remove Guidelines
- White - Mirror Image (For Front Facing applications)
- Purple - Flip Image (For Horizontal mounting)

DO NOT CUT the wire loops until you have the camera connected, powered up, and displaying on the screen.

Step 5B – Connecting the Camera: When installing your Front Camera three connections will need to be made:

- Power
 - Red Wire for 12v power
 - Black Wire to be grounded to a chassis ground
- Video
 - The Male Yellow RCA connection on the end of the camera wire will need to be connected to the unmarked female yellow RCA connection on the Switching Relay

The diagram below outlines the connections:

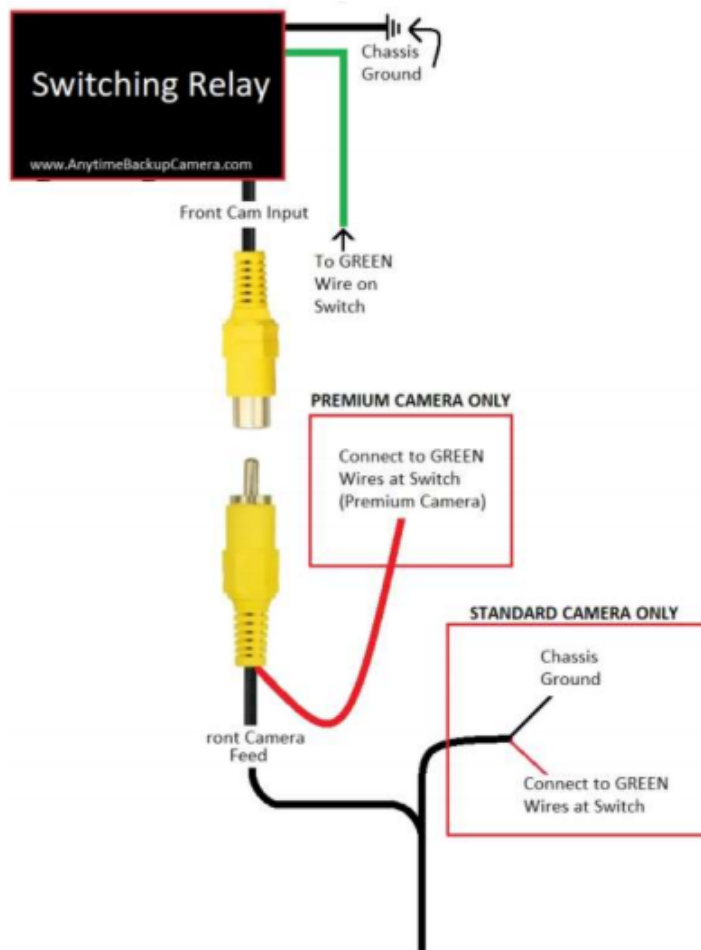

Figure 10 - Front Camera Connections



When connected correctly you will have the Red power wire from the camera connected with the Green wire from the Front/Rear Switch AND Green wire from the Switching Relay. Connecting this Red Power wire from the Front Camera to the Green wires at the switch is the only time you will connect unlike colored wires together. With both cameras, Premium and Standard, the black wires will need to be grounded to a chassis ground.

- For the Premium camera, you will have a short Red Pigtail coming off the RCA plug to use for power inside the vehicle cabin. This is the wire to connect with the two Green wires. Under the hood there will be another two wires, Red and Black. The Black wire should be grounded to a chassis ground and the Red wire WILL NOT BE USED. This Red wire under the hood can be tapped up and tucked aside. It is important that this red wire is protected and cannot contact any ground points as it will be live with power when the camera is in use.

Step 5C – Mounting the Front Camera: This is the final step you should complete. Since mounting the camera involves drilling a hole in your vehicle, we strongly recommend connecting all power and video wires and have the camera powered up and displaying on the screen to test everything works properly prior to drilling any holes. It is helpful to have another person help here to hold the camera in place while another views the screen to ascertain the mounting location prior to drilling the hole. In most applications we recommend mounting the camera directly below the logo in the grill, but it can be mounted anywhere the user likes. To mount you will need to Drill a 5/16 inch hole for the camera nipple to pass through. Be sure to follow the mounting orientation instructions in step 5A to be sure you are mounting your camera appropriately.

Complete component diagram on next page ...

Component Diagram

Anytime Backup Camera Components

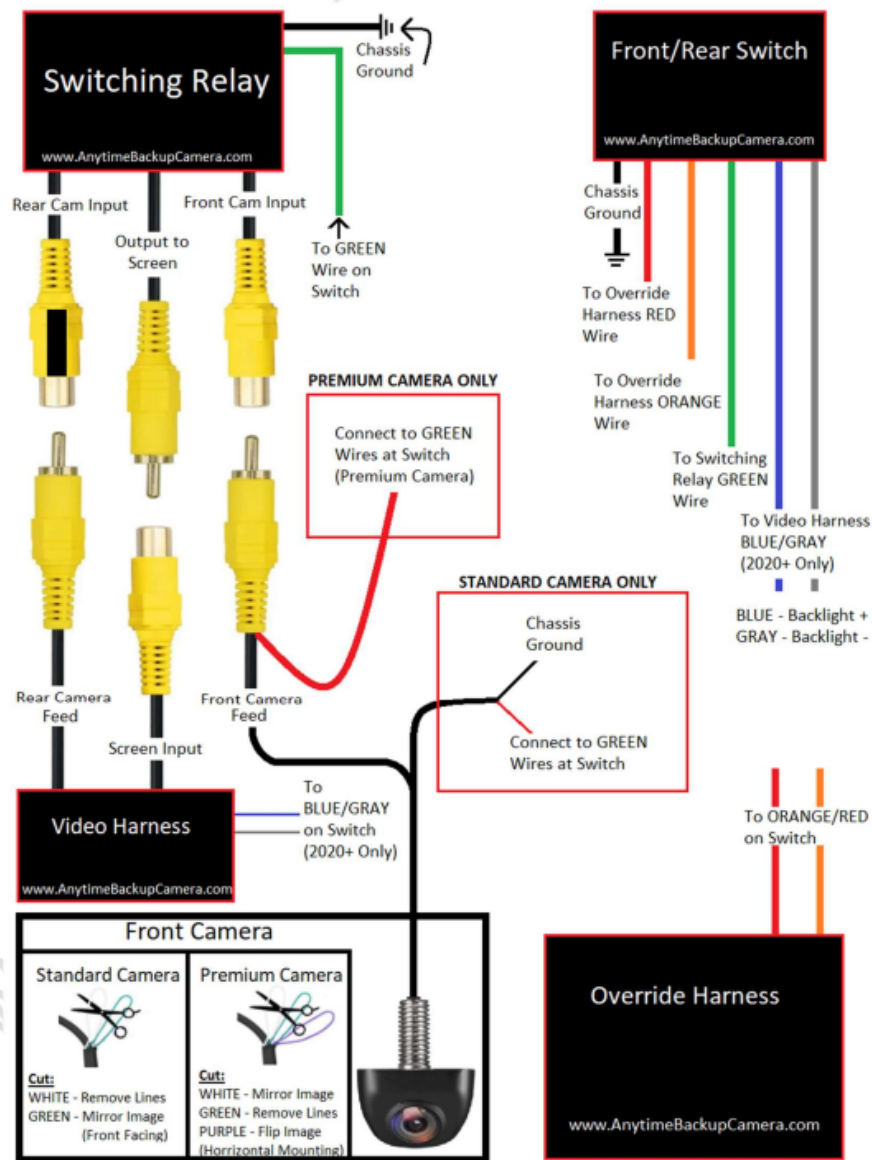

*For Premium Camera Only - Ground Black wire under the hood and tape up additional RED wire as it will not be used.

Revised 12/16/2020
www.AnytimeBackupCamera.com