

# AC-630

more compact • higher capacity  
25 PSI MAOP, 1320 cfh at 2-inch w.c. differential

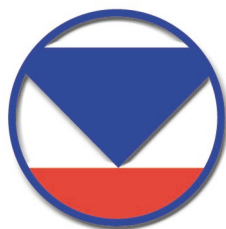

**AMERICAN**  
METER COMPANY

# AC-630

- Convoluted diaphragms
- Unique valve design
- Smaller meter profile
- Superior corrosion resistance
- Regular or TC tangent
- Automatic meter reader capability
- Permanent lube bearings
- 20 LT, 30 LT, 45 LT and #3-4 Sprague connection sizes
- Full warranty
- Pointer or odometer index

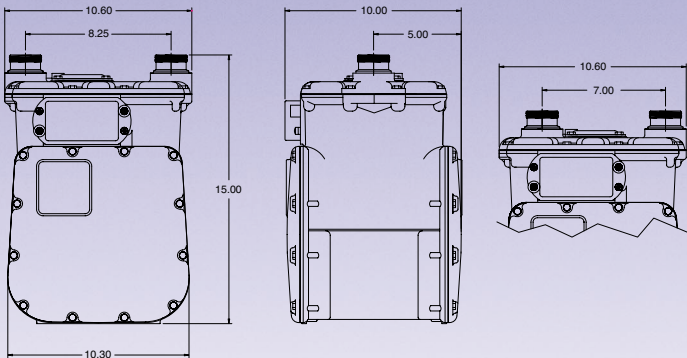

**WEIGHT = 21 lbs.**

**Reference Materials**

- Installation Instructions . . . . . AIM-3715
- Operation/Maintenance Manual & Video . . . . . 52722P002
- Repair Parts List . . . . . RPL-3850

**AMC Quality System**

QMI is Accredited by:



ISO 9001 Certified Certificate #006697



Dutch Council for Accreditation

**SAVE MONEY —** on installation and maintenance with the AC-630. Long-term performance is proven with 40 years of craftsmanship that have gone into its development. Plus, just one serviceperson is needed to install the 21 lb. AC-630, reducing your costs and lowering the possibility for injury.

**Rated Gas Capacity For 0.60 S.G. Gas**

Inlet Pressure PSIG	Inches W.C. Differential	Capacity SCFH
.25	1/2"	630 <sup>1,2</sup>
.25	2"	1320
1	2"	1340
2	2"	1390
5	2"	1515
10	2"	1710
15	2"	1890
20	2"	2010
25	2"	2160

1 - Propane - 397 cfh  
2 - Butane - 347 cfh

**AC-630 Capacity Curve @ .25 Inlet**

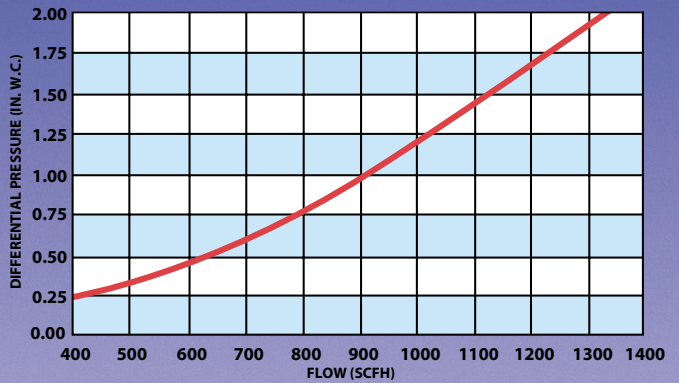

**AC-630 Proof Curve**

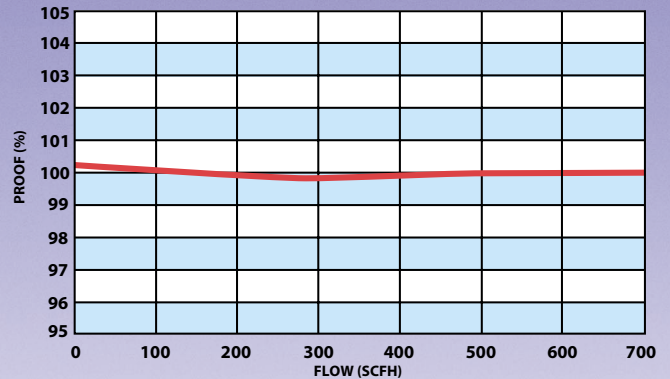

**Order Information:**

Model No.: \_\_\_\_\_  
 Regular or Temperature Compensated: \_\_\_\_\_  
 U.S. or Metric: \_\_\_\_\_  
 Size of Connection: \_\_\_\_\_  
 Type of Index: \_\_\_\_\_  
 Proof Preference: 100 +/- 1% \_\_\_\_\_  
 Standard Color or ASA #49 Grey: \_\_\_\_\_

Contact American Meter with any questions or orders at the address and phone number below.

*American Meter Company has a program of continuous product development and improvement and, therefore, the information in this bulletin is subject to change or modification without notice.*



Measurement Engineers Since 1836  
Yesterday...Today...Tomorrow

300 Welsh Road, Building One  
Horsham, PA 19044-2234  
Phone: 215/830-1800  
Fax 215/830-1890  
www.americanmeter.com



275 Industrial Road  
Cambridge, Ontario  
Canada N3H 4R7  
Phone: 519/650-1900  
Fax 519/650-1717  
www.americanmeter.com

