Mounting & Maintenance

Oversize Pulley Wheel System
for Shimano Dura Ace 9250 + Ultegra 8150



CERAMICSPEED

Maintenance

No set of rules can be made for how often your Oversized Pulley Wheels are to be maintained. Maintenance frequency depends on the weather conditions that you are riding in.

A worn chain will increase the wear on the pulley wheels significantly, so make sure that you change your chain before it is completely worn out. Under



normal conditions, we recommend that you service the Oversized Pulley Wheels when you have ridden under wet conditions, washed your bike or each time you lubricate the chain. For normal maintenance, add a drop of oil into the lubrication points (see the page 3) for optimal performance. Make sure to position the OSPW System horizontally to ensure that the oil reaches the Oversized Pulley Wheel bearings.

We recommend the use of CeramicSpeed Oil on the OSPW System. This can be purchased from the CeramicSpeed dealers worldwide or from our webshop. Watch our maintenance video on ceramicspeed.com in the Support section.

Extended Maintenance

Approximately once every half a year we recommend that you perform an extended maintenance. In this case, you should dismount the Oversized Pulley Wheels from the cage, remove the seals from both sides and clean all parts in a shaker with degreaser. After cleaning, dry the components off, put two drops of oil onto the CeramicSpeed Balls, place the seals back on and remount the Oversized Pulley Wheels. When dismounting the cage plates, you will need a 2.5 mm Allen Key for the pulley wheel bolts (see page 3) and a 2 mm Allen key for the tower bolts. To remount the screws, tighten the pulley wheel screws up to a max torque of 1 Nm and the tower bolts up to 0.3 Nm. For this, a torque tool is recommended. If you're riding in wet and muddy conditions, we recommend you to perform an extended maintenance more frequently and replace oil with All Round Grease for better protection.

Mounting the CeramicSpeed Oversized Pulley Wheel System for Shimano DA 9200

Pos.	Description
1	Pulley wheel bolts
2	Tower bolts
3	Back cage plate
4	Upper pulley
5	Lower pulley
6	Cage pivot
7	Front cage plate
8	Pulley wheel lubrication points
9	Derailleur body spacer only for Dura Ace 9250

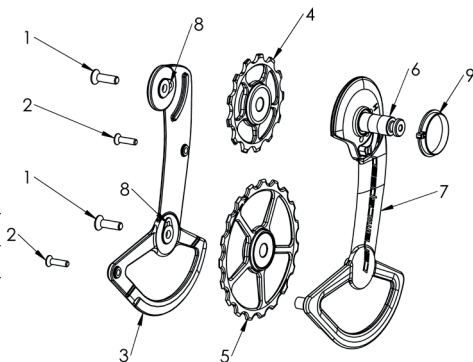

Tools required

For the installation of your new CeramicSpeed Oversized Pulley Wheel System for Shimano Dura Ace 9250 and Ultegra 8150, you will need the following tools:

- A. Chain Tool
- B. T10 Torx® Screwdriver
- C. Philips screwdriver no. 2



A

B

C

Mounting Manual

To ensure the very best in riding performance it is vital that your new OSPW System is mounted correctly. Follow these instructions to install your OSPW System for Shimano Dura Ace 9250 and Ultegra 8150:

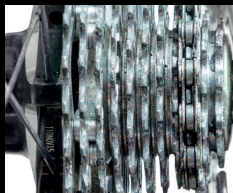

1. Begin with your bike mounted in a stand and remove the rear wheel.

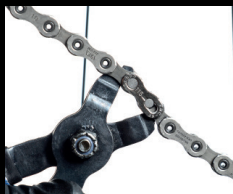

2. Remove the chain with a proper chain tool. Upon completion of installing the OSPW System you will need to use a new, longer chain. Note: it is not recommended to add links to a previously ridden chain.



3. Locate the black mounting screw on the bottom of the derailleur body. Use a T10 Torx screwdriver to remove the black T10 mounting screw. Only half of the screw is threaded. Once the screw is about 1 cm out and the threads are not engaged, slide the screw the rest of the way out with your hand. Secure the cage in the derailleur body with your thumb.



4. Shift the derailleur up to the cage can rotate past the body. For Ultegra 8150, remove the rotation stop screw using a Phillips screwdriver, and carefully allow the cage to unwind. For Dura Ace 9250, pull the cage by hand away from the derailleur body until the stop tower is free and carefully allow the pulley cage spring to unwind, releasing the spring tension. Your derailleur cage will appear to be upside down.



5. Slide out the original pulley cage and spring assembly, careful not to drop the pulley spring and plastic spacer.



6. Remove the spring and plastic spacer from the Shimano cage. The end of the spring is hooked to lock into the pulley cage. Keep these aside as you will reuse these for the installation of the OSPW System on Ultegra 8150. You do not need the plastic spacer for the Dura Ace 9250 as you will use the thicker supplied spacer with the OSPW .

7. Unpack the OSPW System.



8. For Ultegra, place the original spring and plastic spacer over the mounting post of the OSPW System in the same manner they were removed from the stock cage. The hooked end goes toward the OSPW cage as well as the flat edge of the plastic spacer. For Dura Ace, you will use the thicker spacer supplied with the OSPW .



9. Note the four spring tension settings on the OSPW cage: from H (high) to L (low). The L tension setting will reduce both chain tension and friction, but will also result in slightly compromised shifting performance. The H tension setting will deliver the highest frictions levels but deliver the strongest chain retention for rougher roads or mixed surfaces.



10. Select the spring tension hole second from 'L' (second lowest tension) and insert the hooked end of the spring completely. This may need to be pressed firmly. The plastic spacer will rest freely on the spring until aligned at the back of the derailleur body.



11. Rotate the derailleur body back, align the mounting post of the OSPW System to the back of the derailleur body with the cage pointing to the front of the bike. Align the tension spring and plastic spacer with the slot on the derailleur body and insert until the cage is flush to the derailleur. Ensure the OSPW cage rotates smoothly and the spring is properly secured.

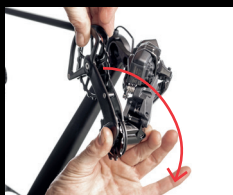

12. Hold the OSPW cage against the derailleur body and rotate counter-clockwise (first up and then to the back of the bike and downward) until you feel the ramped stop click past the stop point on the derailleur.



13. Secure the cage by reinstalling the original black T10 screw (removed at step 3). Installation torque is 1Nm. Your new OSPW System is now installed.

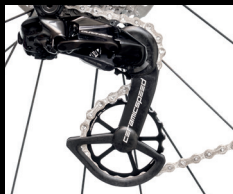

14. Shift the derailleur down to the bottom and install the rear wheel. Install a new chain according to the guide on the following page. Ensure the derailleur hanger is accurately aligned, check the upper and lower stops of the derailleur, and set the b-limit gap between 4-7mm at the largest cog and upper pulley. Adjust the Di2 trim for proper alignment between the cogs and pulley wheels. If in doubt, have a qualified mechanic make the final gear adjustments. Note: For the best result use an original Shimano Ultegra or Dura-Ace Cassette (11-34T Max)

Chain length

Test the present chain length acc. to the description below.
If it turns out to be necessary to change the chain length, follow the description below.



STEP 1: Place the chain on the small chain ring, through the derailleurs cage, and the smallest cog on the cassette. If you are using an electronic group set that does not allow the 'small-small' combination, shift to the smallest cog possible while in the small front chain ring. To find the correct chain length, at the bottom span between chain ring and derailleurs cage, pull the two chain ends together. The lower part of the cage should start to move downwards, away from the cassette, as referenced in the second image.

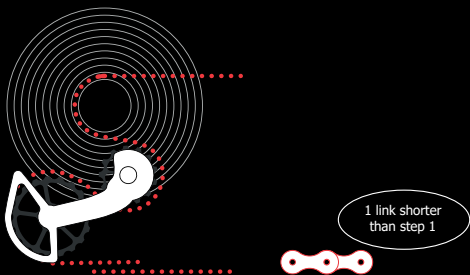

STEP 2: When tension is applied on the chain and the OSPW System appears to be aligned as the diagram above, cut the chain 1 full link (inner + outer link combination) shorter to ensure adequate chain tension is present in all gears (small chain ring/smallest cog allowed on the cassette).

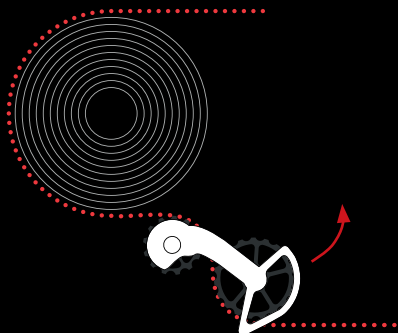

STEP 3: With the chain now cut to length it is important to test the clearance of the OSPW System when rear derailleur is set in the biggest chain ring and the largest cog on the cassette. Just as the arrow indicates, the cage should be able to rotate further counter clockwise. It is important that there is 3+mm clearance between the upper pulley wheel of the OSPW System and the largest cog on the cassette. If you find the clearance is not enough, adjust the B-tension accordingly. For derailleurs without a B-tension adjustment, you may need to remove additional links, one at a time, to increase the clearance until adequate.

Spring tension

For the initial setup you should select the spring tension hole next to L (second lowest tension). This provides the best balance between low tension/resistance and optimal shifting under standard conditions. If shifting response is too slow, and/or if you ride on rough surfaces (cobble roads, rough gravel, or cyclocross), you may change the spring position to a higher tension at or next to H.

Up to Lifetime warranty

Thankfully, we do not have to deal with warranty issues often. Nevertheless, we are happy to introduce you to our comprehensive warranty program.

Standard products 4 years

Bottom Brackets

Pulley Wheels

Wheel Kits Headsets

Single Bearings

Coated products + OSPW Cages Lifetime warranty

Bottom Brackets

Pulley Wheels

Wheel Kits Headsets

Single Bearings

We are committed to manufacturing and delivering the best ceramic bearing products in the industry. Should your CeramicSpeed product not live up to your expectations, and this is caused by defects in materials and/or workmanship, we encourage you to contact us.

Register your product within the first 30 days of purchase on ceramicspeed.com/sport under the section Support. Should you thereafter, and within the warranty period need to file a claim, please return to the same section on our website and fill in your claim. We will always strive to revert to you concerning your claim within 24 hours.