

06

iBLAST Series

HAVE AN INTELLIGENT BLAST!

THE ONLY INTELLIGENT MAINTENANCE FREE HAND DRYER IN THE WORLD

FEATURES

- Vandal proof-not scratchable with any sharp object
- Fastest drying time on the market
- This is the first Intelligent Blast. Same power, same design plus new hi-tech features
- Unique Intelligent connectivity
- Communicates the diagnostic in case of defaults
- Capability of establishing usage frequency
- Controllable remotely via text message or the web portal
- Communicate via GSM or Ethernet with the data center
- **Exclusive : Adjustable output airflow temperature**
- Smallest footprint on the market
- Universal voltage: automatic voltage switching for easy installation
- Designed for easy installation
- Contributes to LEED and BOMA building certifications
- Tamperproof screws

DIMENSIONS

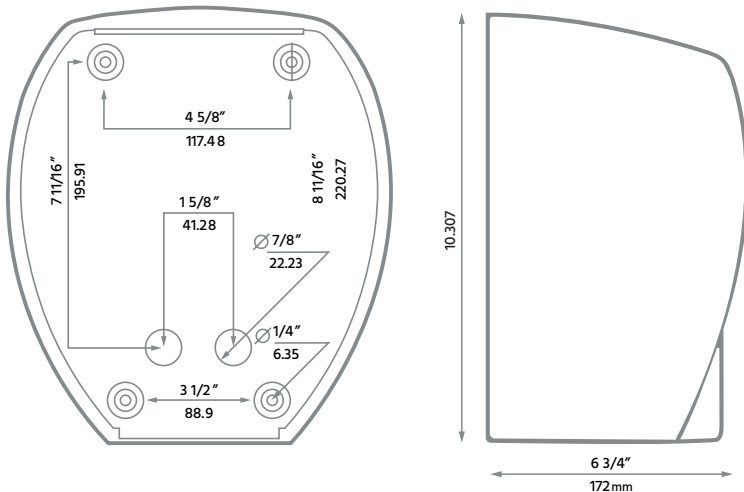

APPLICATIONS

- Washrooms and clean up areas, commercial facilities, factories, restaurants and hospitals
- schools, pools and gyms.
- Made for high traffic public areas

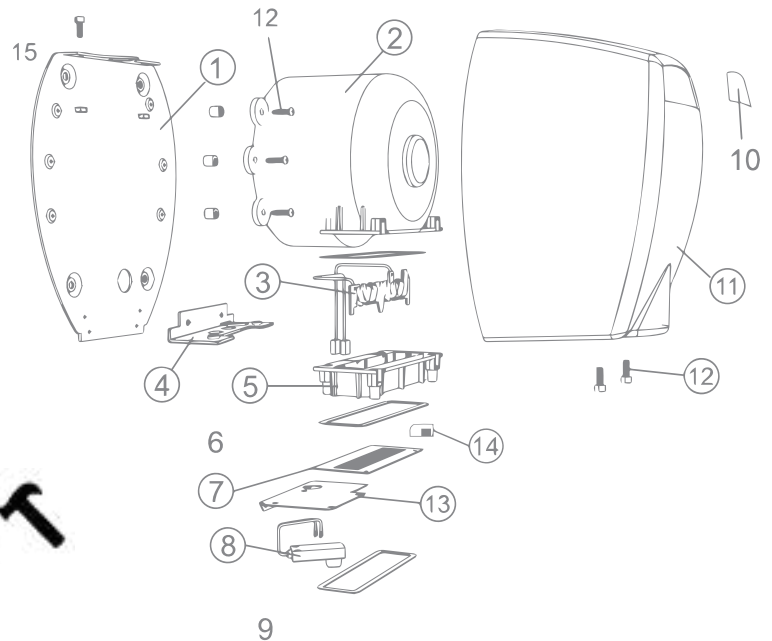

REPLACEMENT PARTS

1	Baseplate	9	Nozzle
2	Motor Assembly	10	Nameplate
3	Heating Element	11	Cover
4	Inlet Grill	12	Fasteners
5	Element Housing	13	Sensor Mounting Plate
6	Circuit Board	14	Sim Card
7	Outlet Grill	15	GSM Antenna
8	Sensor		



White

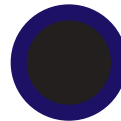

Black



Stainless Steel



Chrome

SPECIFICATIONS

Voltage Universal 115-230*VAC (*50/60Hz)
Wattage 1450 W at 5.2A (230VAC)
Motor Vacuum Motor, 36,000 RPM (outside the enclosure)
 5/8HP 20,000 RPM (installed in the enclosure)
Colour White, Black and Stainless Steel
Finish Porcelain enamel.
Heating Element 725w resistance coil.
Construction Material Reinforced Steel

Controls & Wiring Automatic resetting thermostat with cutout when airflow is restricted. Infrared sensor cutout two seconds after hand removal, and 85 seconds after initiating drying.
Installation Removable predrilled baseplate for easy mounting.
Warranty LIFETIME.
 CSA certified for use in Canada and the U.S.
 CE approved for use where applicable.
Patent Pending

ORDERING GUIDE



Model No.	Color	Watts cold air hot air	Volts Hz	Air Velocity LFM	Air Volume CFM	Noise dB	Dimensions (W x H x D) (mm/in.)	Weight (kg/lbs.)
C-300000000	White	725-1450	115-230,50-60	19,000	100	78	235 x 280 x 170 (9.25 x 11.02 x 6.69)	5/11
C-300240000	Black	725-1450	115-230, 50-60	19,000	100	78	235 x 280 x 170 (9.25 x 11.02 x 6.69)	5/11
C-300220000	Brushed stainless steel	725-1450	115-230, 50-60	19,000	100	78	235 x 280 x 170 (9.25 x 11.02 x 6.69)	5/11
C-300230000	Chrome	725-1450	115-230, 50-60	19,000	100	78	235 x 280 x 170 (9.25 x 11.02 x 6.69)	5/11