

Sensing Devices

Passive Infrared

Wall Switch Sensors

Features

- Designed for use on 120 AC circuits, no neutral required, fast retrofits
- Manual adjusting, auto ON operation
- Wallplate sold separately

Ordering Information

Description	UPC Number	Catalog Number
Manual adjusting, auto ON operation; 120V AC only	783585428062	WS1020I

Listings

cULus listed to UL 773A

Specifications

Housing	Flame retardant UL 94 V-0 ABS
Lens	Polyethylene
Dimensions	Face 2.59"H x 1.30"W, 0.61"D (from wall out)
Mounting Height	45 to 54 inches above floor
Mounting Strap	Steel

Performance

Controls	
Front Press Switch	ON/OFF
Service Switch	OFF (service); ON (normal operation)
Time Delay	6 seconds to 20 minutes (default set to 10 minutes)

Electrical	
Load Capacity	120VAC, 600W Incandescent, 5A Ballast, 5A CFL/LED, 277V; Horsepower rating 1/6

Environmental	
Operating Temperature	32°F to 122°F (0°C to 50°C) with rate of change not exceeding 20°F(11°C) per hour
Storage	-40°F to 150°F (-40°C to 65°C); 20% to 90% non condensing relative humidity

Sensing Indicators	
Passive Infrared	Red LED

HUBBELL

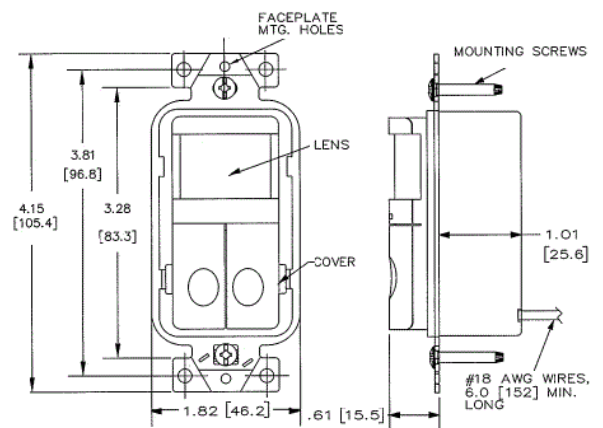

Complementary Products

Nylon Wallplate	NP26I
SS Wallplate	SS26
Snap-On Wallplate	NPS26I

Online Resources

eCatalog

Dimensions in Inches (mm)

Hubbell Wiring Device-Kellems • Hubbell Incorporated (Delaware) • 40 Waterview Drive • Shelton, CT 06484

Phone (800) 288-6000 • Fax (800) 255-1031 • Specifications subject to change without notice.

