



# MARCUS

Marcus Transformer LTD  
 Phone: 1-800-267-7376  
 Fax: 1-866-205-7526  
 Email: Info@marcustransformer.com

## TECHNICAL DATA

SINGLE PHASE CONTROL TRANSFORMER

### DESCRIPTION

MODEL	MC500W
Type	Enclosed, Indoor application
VA	500
Primary (Volts)	120 / 240
Secondary (Volts)	120 / 240
Input / Output Amps	4.17, 2.08 / 4.17 , 2.08
Temperature Rise	95°C
Insulation Class	B (130°C)
Frequency	50 / 60Hz
Polarity	additive
Noise level	less than 40DB
Winding	Copper
Approvals	UL listed CSA approved

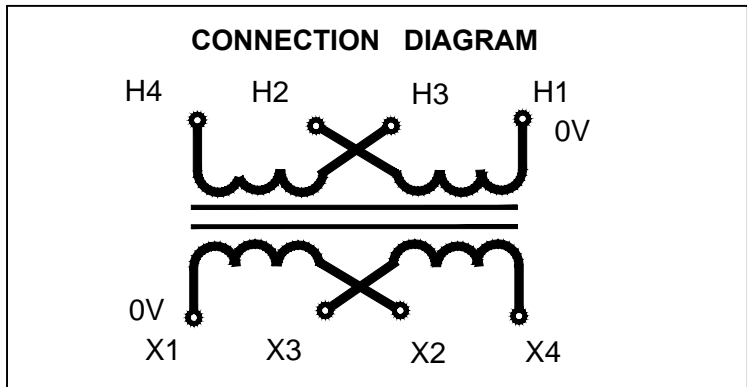

### WIRING CONNECTION

PRIMARY :		
VOLTS	INTERCONNECT:	CONNECT LINES TO :
120	H1-H3 AND H2-H4	H1-H4
240	H2-H3	H1-H4
SECONDARY :		
VOLTS	INTERCONNECT:	CONNECT LINES TO :
120	X1-X3 AND X2-X4	X1-X4
240	X2-X3	X1-X4

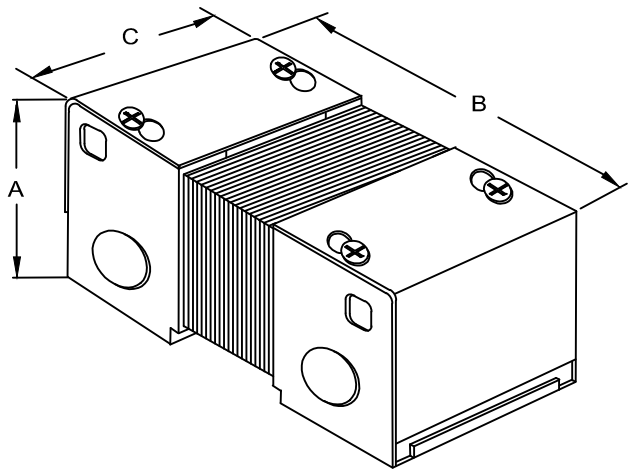

LETTER	MOUNTING SLOTS INCHES / MM
	a b
V	0.30 x 0.560 7.6 x 14.2

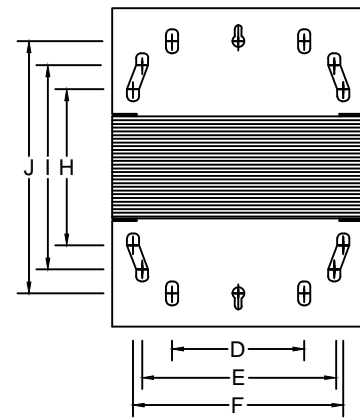
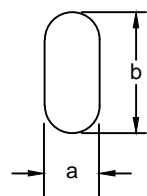

### DIMENSIONS INCHES / MM

VA	A	B	C	D	E	F	G	H	I	J	K	L	M	SHIP WEIGHT LBS / KG
500	4.70 119.4	6.63 168.4	5.25 133.4	2.75 69.9	4.00 101.6	4.38 111.3		3.25(V) 82.6	4.25(V) 108.0	5.25(V) 133.4				14.50 6.6