

Cargo Truck Owners Manual





Table of Contents

I. Important Notice

II. Note

III. Specification

IV. Driving Way and Operation Method

V. Adjustment and Maintenance of Electric Tricycle

VI. Common Troubles and Troubleshooting

VII. Wiring Diagram

I. Important Notice:

- ① Please read this manual carefully before use.
- ② Please obey the traffic rules in driving.
- ③ Do not lend the electric tricycle to those who cannot operate it.
- ④ Avoid speeding and overloading.
- ⑤ Avoid driving on the road with potholes, mud or gravels.

II. Notice:

- ① The electric tricycle should be driven on the trails.
- ② When turn during driving,, the speed must be slow down and the minimum diameter of the turning circle should not be greater than 6m.
- ③ The unauthorized disassembling of the vehicle body will bring security risks to your vehicle, which is likely to cause danger.
- ④ Before riding the vehicle, you must confirm the safety and reliability of the fasteners such as the handlebar, the saddle and the wheels, to avoid accidents.

Warning: This product is suitable for healthy adults and it should be prohibited for minors, the disabled, as well as the patients with cardiovascular and cerebrovascular diseases.

Note: When the electric tricycle is running at the speed of 20km/h, its dry braking distance should not be more than 6m and its wet braking distance should not exceed 15m.

III. Specification

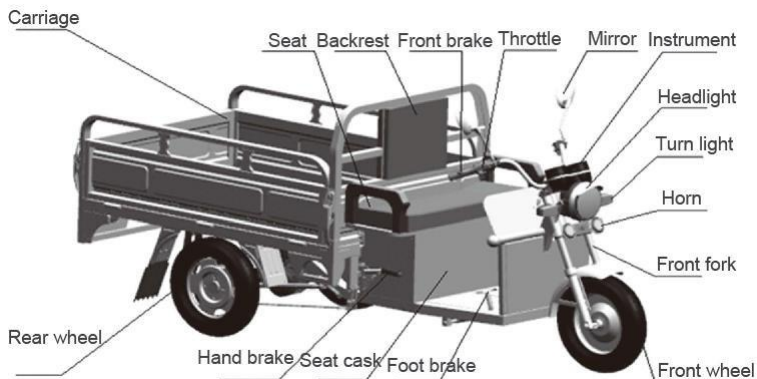

Performance	Max. speed	$\leq 22\text{Km/h}$
	Distance per charge	$\geq 35\text{Km}$
	Product Size (mm)	2520 L x 850 W x 1200 H
	Max. capacity	$\leq 300\text{Kg}$
	Net Weight	179Kg
	Max. steering angle	$\leq 45^\circ$
Battery	Type	Lead-acid
	Voltage	48V (12V*4)
	Capacity	48V20Ah
Controller	Under voltage value	$42 \pm 1\text{V}$
	current limit value	$28 \pm 1\text{A}$
Charger	voltage	48V
	Output voltage	$59 \pm 0.2\text{V}$
	Charge current	2.8A

IV. Driving Way and Operation Method

About Driving Schematic

Before driving, firstly check if the tire pressure of the vehicle is adequate and if the braking performance is intact, etc.

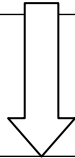

Insert the key into the power supply hole and rotate it to the file of "ON" (turn it to right), when the power has been turned on. And then check if the power is sufficient.

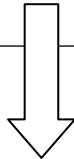

Slowly rotate the speed handlebar to the speed you need for normal driving.

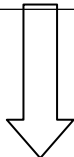

When you need parking, firstly rotate back the handlebar to decrease the speed, and then brake the tricycle, rotate the key to "OFF" and unplug the key.

Display Function diagram

1. Assembling the front wheel

- a. Take out the Cargo bike from the frame.



- b. Place Cargo bike on a flat surface, take out the front fender and front wheel, then assemble them well. And then assemble the front brake cable.



Note: Need to assemble a spacer and two washers on left side of front wheel.



2. Assembling the battery

Firstly put the battery box into the frame under the carriage. Fix the battery box with battery hook and battery clamp provided.

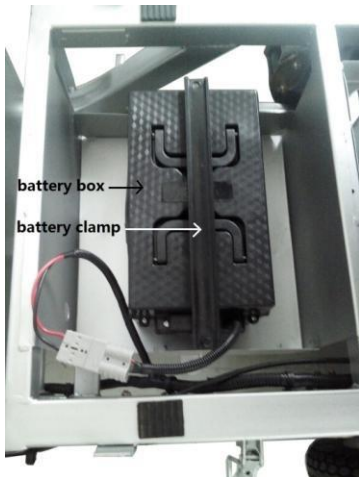

Then open the switch(A).

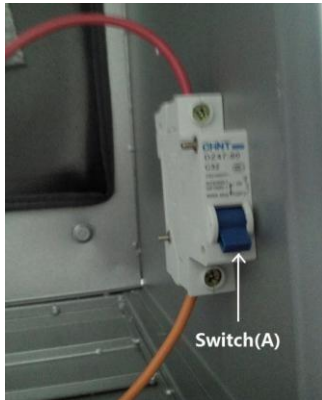

3. Speed switch

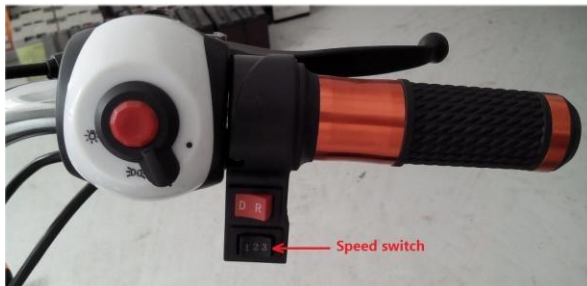

I : low speed II

: high speed III:

middle speed

4. Gear shift

The new Cargo bike has two gears, high-grade and low-grade. When climbing and very difficult to climb, you can stop the Cargo bike, and then change the low-grade to climb.

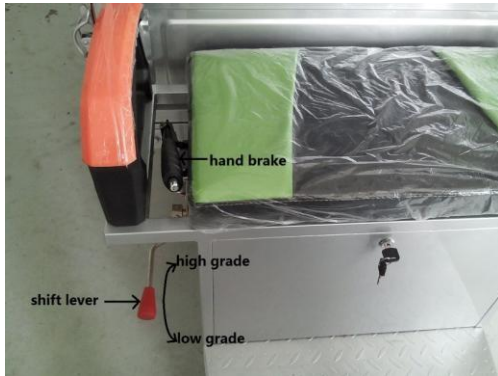

Note1: When changing the gears, you must stop the Cargo bike.

Note2: When stopping the Cargo bike, please pull the hand brake.

V. Adjustment and Maintenance of Electric Tricycle

About Electric Tricycle

- 1、 The newly purchased vehicle is well adjusted. If you have any questions, please show them to the supplier for solution.
- 2、 The replacement of grease SH/T0386 on the parts of ball shaft (front axle, rear axle and front fork parts) should be carried out once a year. The brake lines should be injected with a small amount of engine oil LAN46, GB443.
- 3、 The brake adjusting method is the same with that of the bike. The distance between the brake block and the front wheel rim should not be greater than 3mm. If this distance is greater than 3mm due to wear, please replace the brake block. When the rear wheel brake wear is greater than 1/2, please replace the brake pad.
- 4、 During the use and maintenance, if you find some problems that cannot be solved by yourself, please send your vehicle to the designated repair station for repair. The damage and failure due to the unauthorized removal of the vehicle is not within the free warranty of our company.
- 5、 After the vehicle is used for some time, it should be carried out with a comprehensive adjustment by the professional or

designated repair station, in order to ensure the comfortableness, security and normal life of the vehicle.

About Battery Charging

1. During charging, you should firstly insert the plug of the battery and then the AC power plug.
2. When the indicator light on the panel of the charger is red, it indicates that the charger is charging the battery and when the indicator light of the charger turns green, it indicates that the charger has been into the floating state and the battery should be charged continuously for another 1-2h.
3. After the completion of charging, you should firstly unplug the AC power plug, and then the charging plug.

Notices for Charging

1. During charging the vehicle should be placed in a safe place where the children are not able to touch it.
2. Do not use the charger of different brand or different model for charging.
3. Do not disassemble the charger without authorization because it contains high voltage circuit inside.

4. During charging, do not cover the charger with anything. If there is unusual smell or the temperature is too high, please stop charging immediately.
5. The charger should be used indoors where it is dry with well ventilation.
6. Charging time should not exceed 12h.

Note: Do not touch contacts of battery with your hands or metal objects to prevent burns!

About Battery Maintenance

1. Discharge with large current is negative to the battery

When the electric tricycle is in startup, headwind, uphill and heavy loading, the discharge current of the battery will be large. When the charging is insufficient, the life of the battery will be shortened.

The vehicle should be charged after driving every day. The battery cannot be stored with capacity loss. Even the vehicle is not used for a long time, it must be charged once a month.

2. When the ambient temperature is more than 40°C or less than -10°C, the life of the battery will be shortened. Therefore, in summer, due to the hot weather, the direct sunlight should be avoided for the battery. And in winter, due to the coldness, the battery should be stored and charged indoors. And after the

battery is fully charged, the charging should be extended for 2-3h.

3. When the ambient temperature is -10°C , the power capacity of the battery is only 60%, so every mileage under full charging in winter is less than that in summer.
4. Batteries are consumables and the life of the battery is limited.

VI. Common Troubles and Troubleshooting

Note: In daily use, if the motor, controller and charger cannot work properly, please contact the dealer and authorized service department.

No.	Troubles	Causes of Troubles	Troubleshooting
1	After turn on the power switch and rotate the key to "ON", turn the speed handlebar, but the vehicle will not start.	If the electric lock has bad contact	Replace the power lock
		If the connectors have good contact	Inspect and process
		If the fuse is broken	Open it and inspect
		If the battery wiring has good contact	Inspect and process
		If the controller is broken	Replace the controller
		If the speed handlebar is broken	Replace the handlebar
		If the motor has trouble	Repair or replace the motor
2	Speed adjustment failure or the vehicle is slower at the maximum speed	The battery voltage is too low	Charge it and inspect
		The speed handlebar has trouble	Replace the speed handlebar
		The motor has trouble	Inspect or replace
		Brake handle failure	Replace the brake handle
		The motor parts have trouble	Inspect or replace
		The controller has trouble	Replace the controller
		The battery has trouble or aging	Inspect or replace
		The connectors have bad contact	Inspect or replace the connectors
3	Battery charging trouble	The charging socket has detachment or bad contact	Inspect or replace socket
		The fuse inside the charger is broken	Replace the charger
		The wire connection of the battery pack has detachment or bad contact.	Inspect and put them in order
		The charger is broken.	Replace the charger.
4	Sufficient	The tire pressure is insufficient.	Fully inflate the tire

	follow-up mileage after charging	Insufficient charging or faulted charger	Recharging or replace the battery charger
		The battery is aged or damaged	Inspect or replace the battery
		Faulted controller	Replace the controller
		Transmission parts are not flexible	Add lubricating oil
		The brake is locked or with friction	Adjust the brake
		During Uphill , due to the headwind, there are frequent brakes and more start-up. As well as the conditions of poor roads and low temperature	Try to avoid these situations
		Heavy load	Load according to the standard
5	The vehicle has abnormal noise	The screws are loose	Tighten the screws
		Wear of the movable and fixed parts	Inspect and adjust
		The bearing is damaged or broken	Replace
6	Arduous driving	The brake is locked or with friction	Adjust the brake
		Insufficient tire pressure	Fully inflate the tire
		The transmission parts are not flexible due to the loss of lubricating oil	Inspect and adjust

VII. Wiring Diagram

