

Installation Instructions for Shower kit

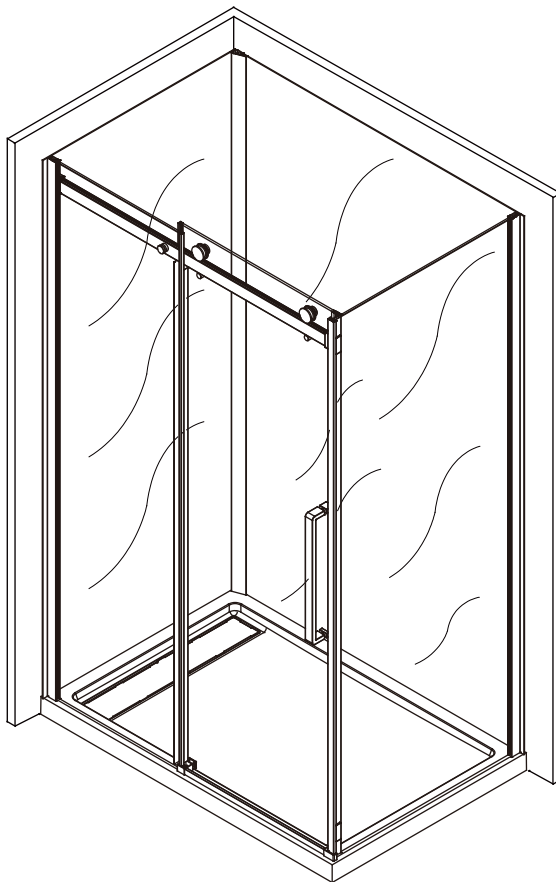

Model : DK1118A

Barcode : 0655343443887

Read all instructions carefully before proceeding.

SAVE THIS GUIDE FOR FUTURE REFERENCE.



◆ General Information

Please inspect the product immediately upon receipt for transit damage, missing packs / parts or manufacturing defects. Damage reported later cannot be accepted. Please handle the product with care to avoid knocks and shocks on any side or edge of the glass.

Note: The safety glass cannot be re-worked.

Please read these instructions carefully before starting the installation.
Special care should be taken when drilling the walls to avoid hidden pipes or electrical cables.

Aftercare Instructions

After use, your shower should be cleaned with soap and water. This is particularly important in hard water districts where insoluble lime salts may be deposited and allowed to build up. Gritty or abrasive cleaners should not be used. Avoid contact with strong chemicals such as organic solvents and strippers. Glass cleaners can be used but with caution. If in doubt, contact the cleaner's manufacturer.

Please keep these instructions for aftercare and customer service details.

~~~~~

## Tools Required

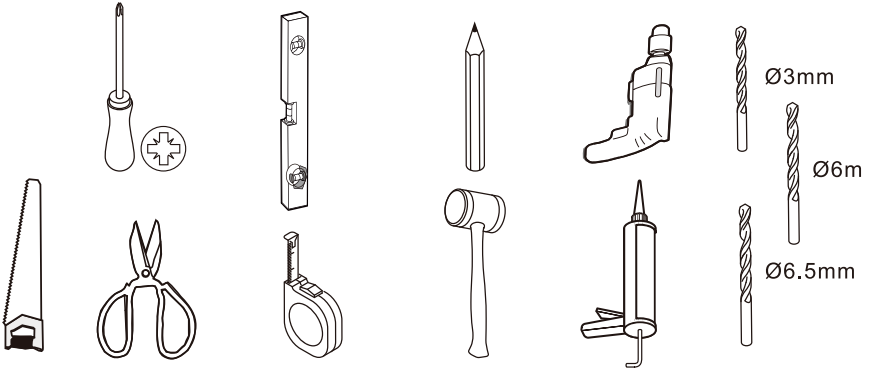

**Note:**  
This product is heavy and may require two people to install.

# Parts and components

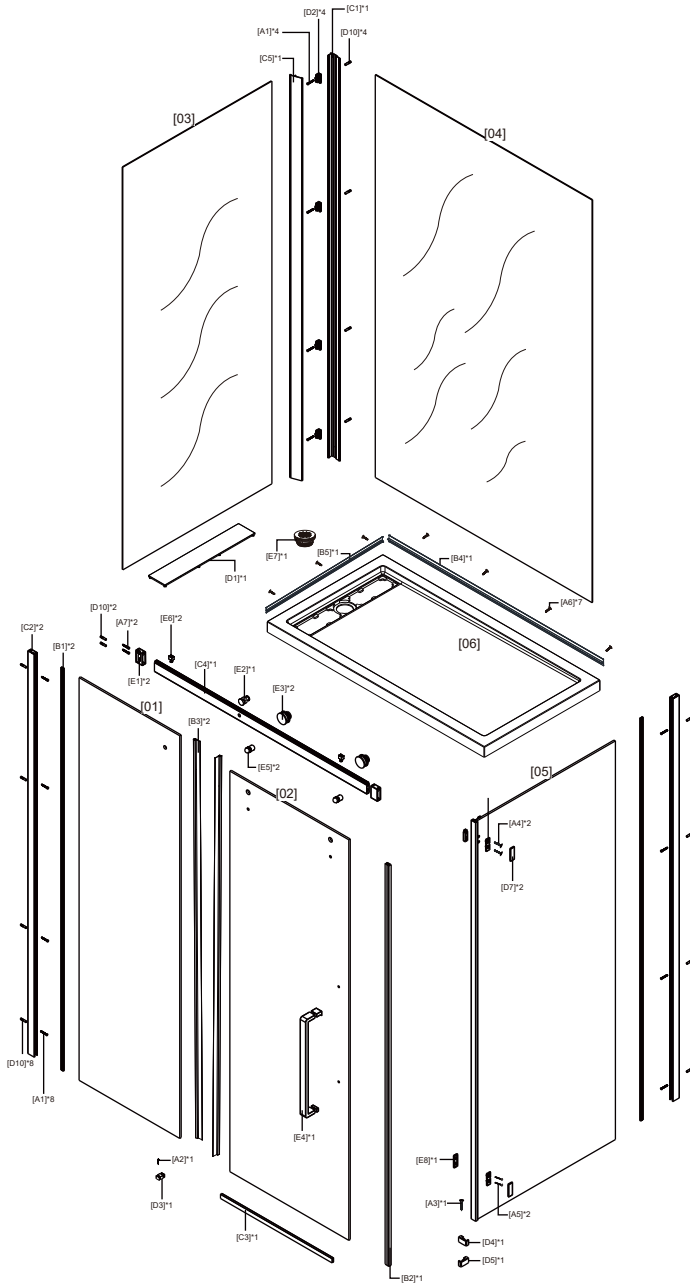

## Parts and components

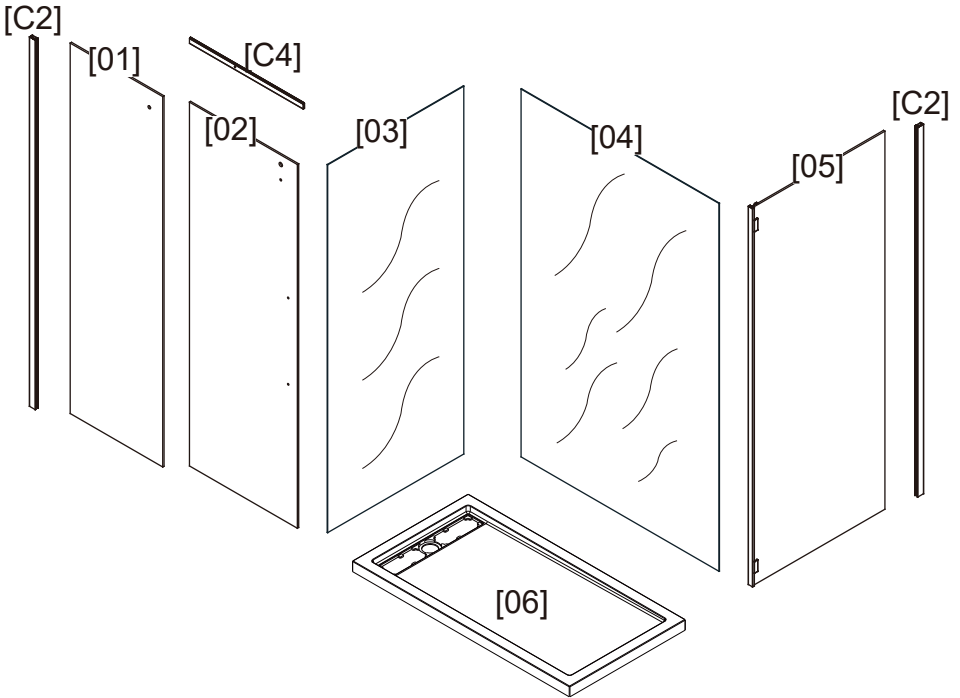



















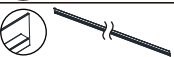











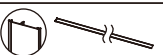



|   |             |    |
|---|-------------|----|
| 1 | Fixed panel | x1 |
| 2 | Door panel  | x1 |
| 3 | Side wall   | x1 |
| 4 | Back wall   | x1 |

|    |              |    |
|----|--------------|----|
| 5  | Side panel   | x1 |
| 6  | Base         | x1 |
| C2 | Wall profile | x1 |
| C4 | Support bar  | x1 |



# Parts and components

| Package A |                                                                                                  |     | Package B |                                                                                            |    |    |                                                                                    |    |
|-----------|--------------------------------------------------------------------------------------------------|-----|-----------|--------------------------------------------------------------------------------------------|----|----|------------------------------------------------------------------------------------|----|
| A1        |  ST4X30mm       | X8  | A1        |  ST4X30mm | X4 | B1 |   | X2 |
| A2        |  ST4X12mm       | X1  | A6        |  ST4X16mm | X7 | B2 |   | X1 |
| A3        |  ST4X10mm       | X1  | D2        |           | X4 | B3 |   | X2 |
| A4        |  M6X22mm        | X2  | D10       |           | X4 | B4 |   | X1 |
| A5        |  M6X16mm        | X2  |           |                                                                                            |    | B5 |   | X1 |
| A7        |  ST4X30mm       | X2  |           |                                                                                            |    | C1 |   | X1 |
| D3        |                 | X1  |           |                                                                                            |    | C2 |   | X2 |
| D4        |                 | X1  |           |                                                                                            |    | C3 |   | X1 |
| D5        |                 | X1  |           |                                                                                            |    | C4 |   | X1 |
| D6        |                 | X2  |           |                                                                                            |    | C5 |   | X1 |
| D7        |                 | X2  |           |                                                                                            |    | D1 |   | X1 |
| D10       |                 | X10 |           |                                                                                            |    | E4 |   | X1 |
| E1        |  3mm           | X2  |           |                                                                                            |    | E7 |  | X1 |
| E2        |  5mm          | X1  |           |                                                                                            |    |    |                                                                                    |    |
| E3        |  2.5mm<br>4mm | X2  |           |                                                                                            |    |    |                                                                                    |    |
| E5        |  3mm          | X2  |           |                                                                                            |    |    |                                                                                    |    |
| E6        |  4mm          | X2  |           |                                                                                            |    |    |                                                                                    |    |
| E8        |               | X1  |           |                                                                                            |    |    |                                                                                    |    |

## Shower reversibility

A. Right to left opening

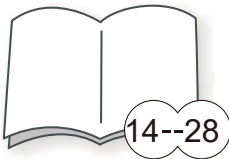
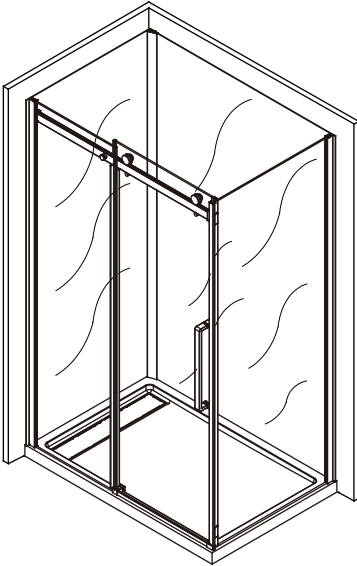

B. Left to right opening

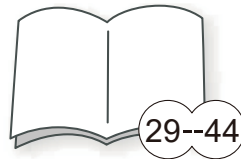
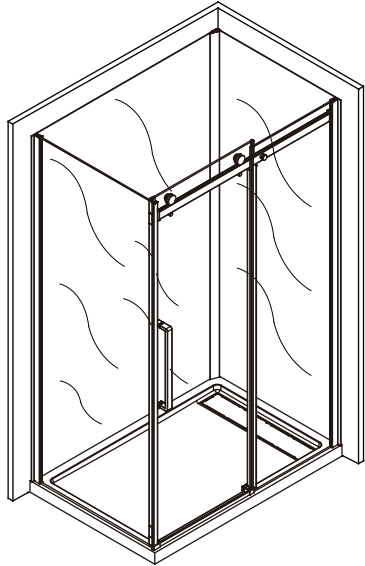

# Base installation

Fig.1

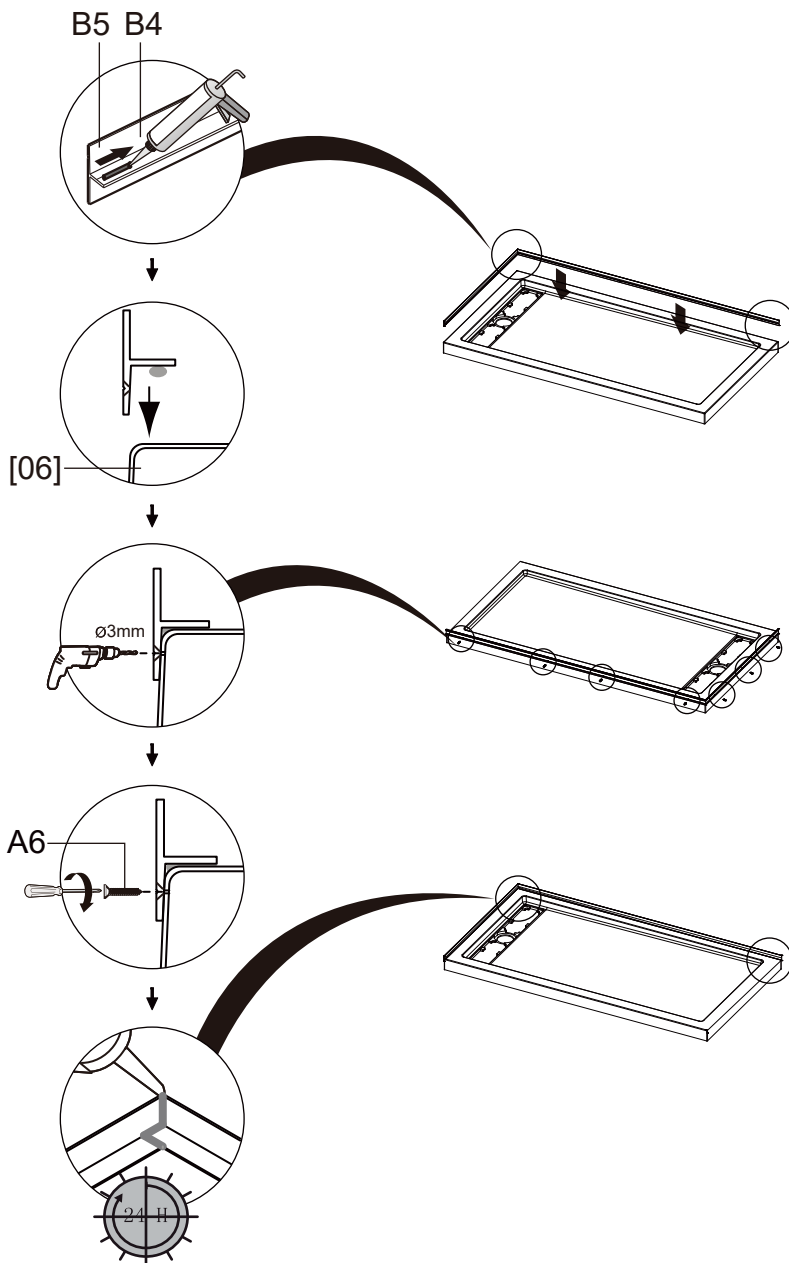

# Preparation of shower area

Fig.2

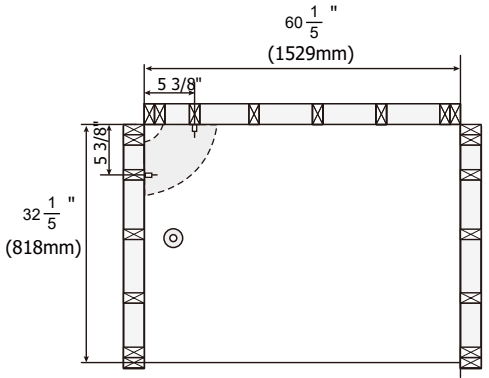
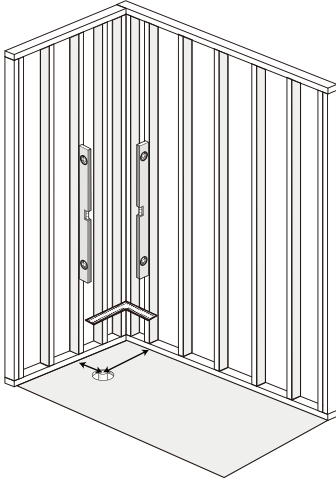
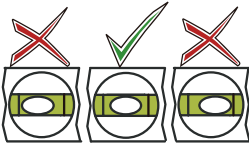

Fig.2: For new construction, and wherever possible for renovation, install an extra stud in each wall centered on 30" and 46" (761mm & 1168mm) from the stud wall corner.



Leveling the floor is critical for wall alignment



For leveling the floor use self-leveling mortar.

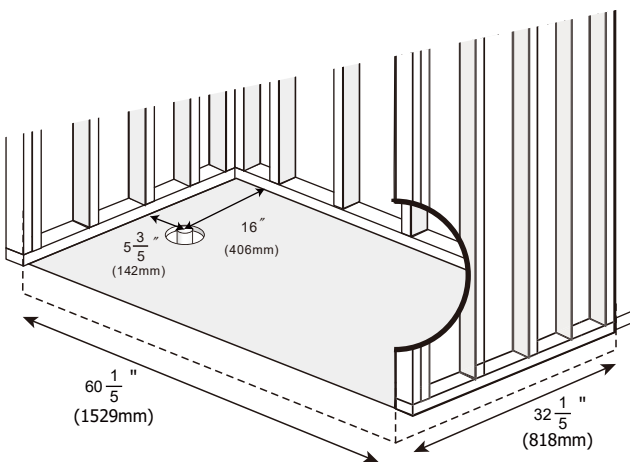

# Preparation of shower area

Fig.3

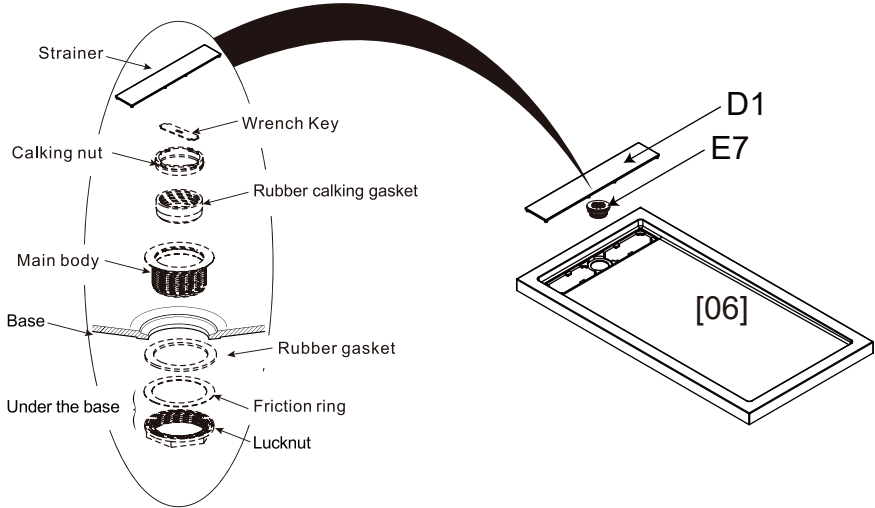

Fig.4

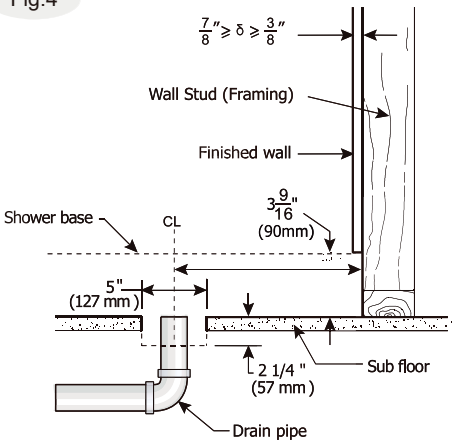

Fig.4: To compensate for any irregularities in your floor, the base must be shimmed properly from underneath to provide a level threshold for mounting purposes. Any shims must support the entire base: not only at one point. Verify this by standing on the base, once shimmed, and check for any spring or bounce in the base. Particularly near drain area. Before final installation (wedge retainer insertion (Fig.4) make sure the base is level and that water drains away properly without "pooling" at any location. Use tape around drain to seal temporarily and pour 1-2 cups of water around extremities of the tray to test drainage.

## Base installation • Installation de la base

Fig.5

Fig.5: Pave the cement at the position where you want to install the base (#3).

Fig.5: Pavé le ciment à l'endroit où vous voulez installer la base (#3).

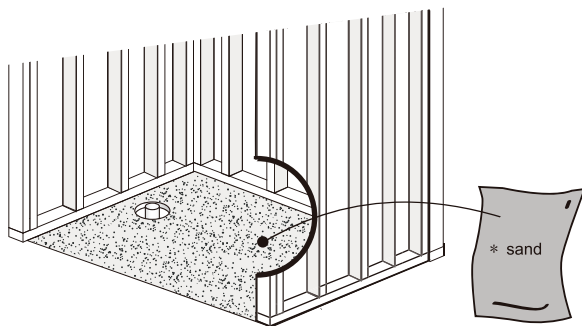
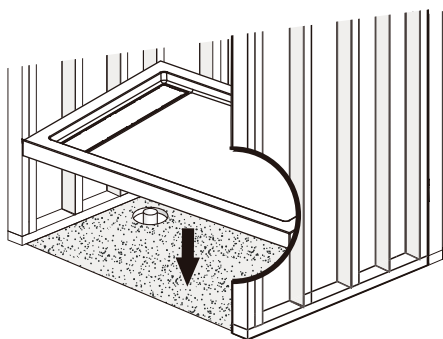

Fig.6

Fig.6: Put down the base on the cement.

Fig.6: Posez la base sur le ciment.



## Base installation • Installation de la base

Fig.7

Fig.7: Apply the silicone to the tiling flange as shown in the illustration.  
Fig.7: Appliquez le silicone sur la bride de carrelage comme indiqué sur l'illustration.

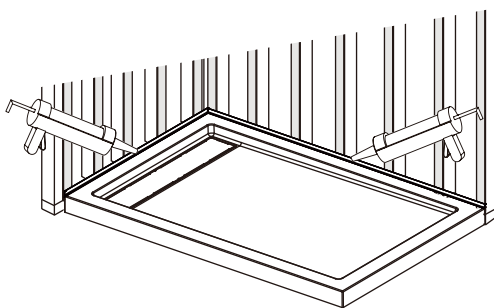
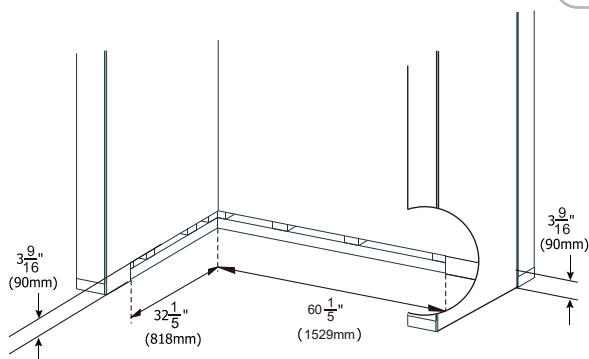

Fig.8

Note: the base is installed against the studs, not the finished walls. If necessary, remove finished wall to expose studs. Fig. 8.

Remarque: la base est installée contre les poteaux, pas les murs. Si nécessaire, retirer le mur de finition pour voir les clous. Fig. 8



## Base installation

Fig.9

Note: The wall panels should be installed at a temperature near 16°C(60°F) and must not be installed in unheated areas where temperatures might drop below 0°C(32°F).

The wall panels can be installed over drywall, plaster, painted walls, plywood or ceramic tile, Wall surfaces must be solid, dry, clean and smooth. Scrape off any loose paint, wallpaper or plaster. It is strongly recommended that raw plaster or new wallboard be primed or water sealed prior to installation.

If the panels are being installed over existing tile, and over 30% of the removed during wall preparation, it is recommended that the remaining tiles also be removed. Existing ceramic tile should be lightly sanded. The vertical alignment from the edge of the shower base each side ( Fig.9 ), and draw plumb lines on

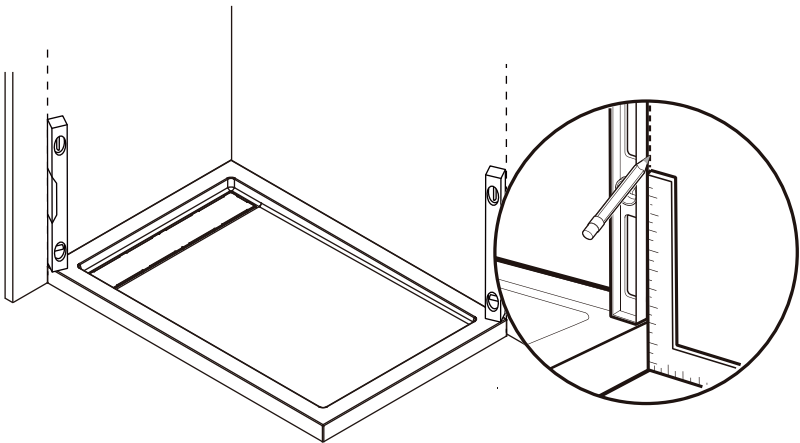



## Wall Installation

Fig.10

Fig.10: Measuring from the shower base and the plumb line on the wall, determine the locations of plumbing fixtures. Cut or drill fixture holes in the wall panel. If a knife is used, be certain that it is wall sharpened. Do not try to cut through the plastic all at once; score it over and over, cutting a little deeper each time until you reach the other side. After having drilled the holes, lay the panel against the wall and check to see if the holes have been drilled in the right locations.

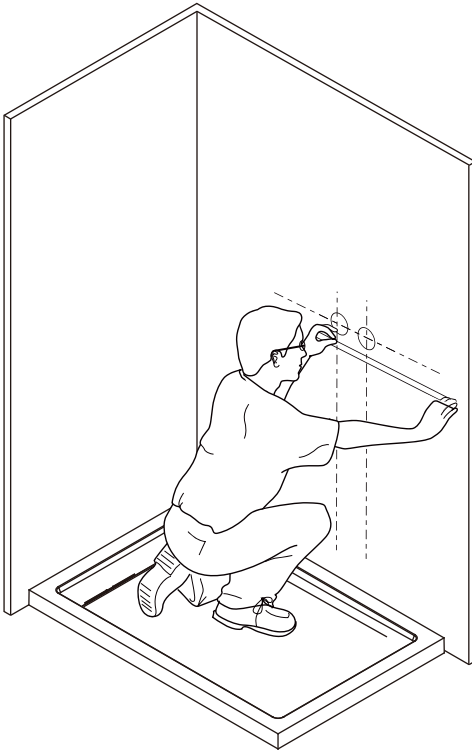

# Decorative column installation

Fig.11

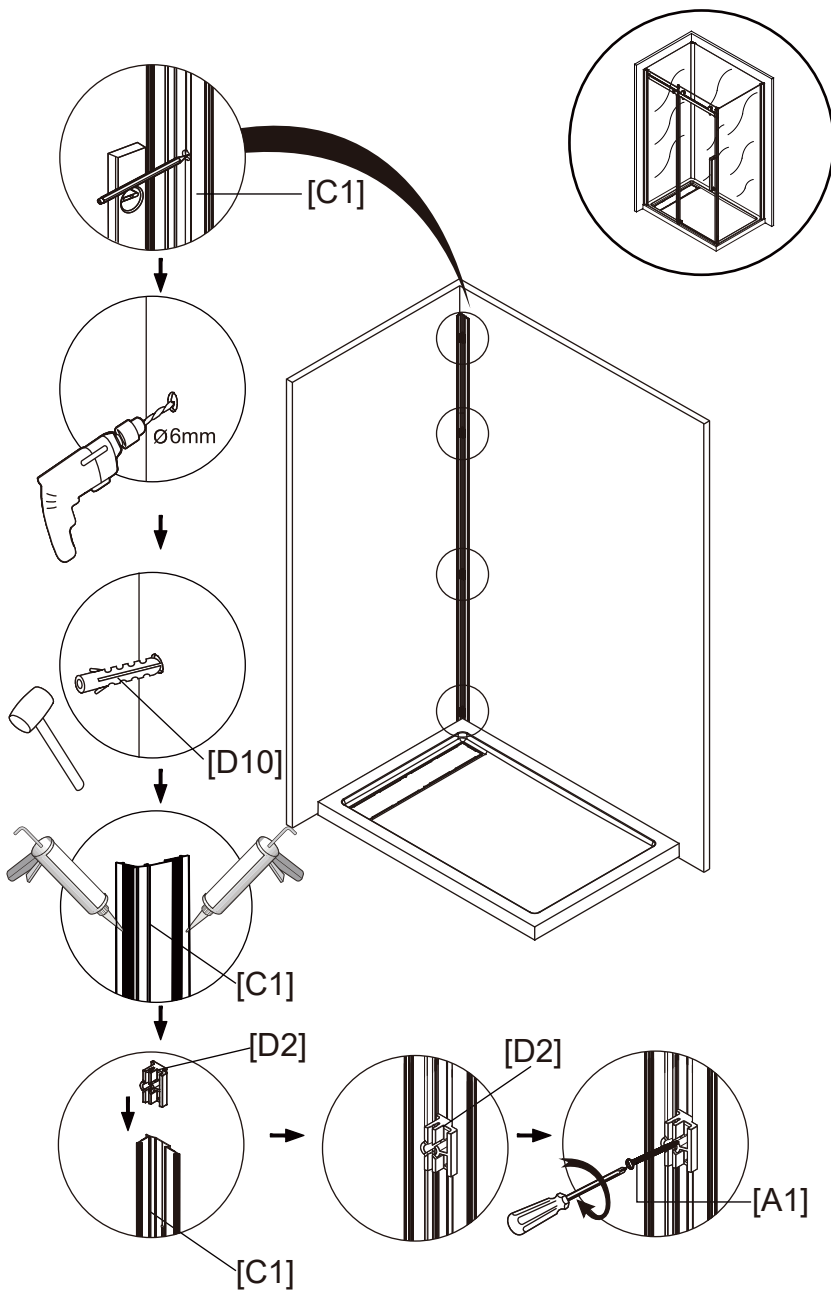

## Decorative column installation

Fig.12

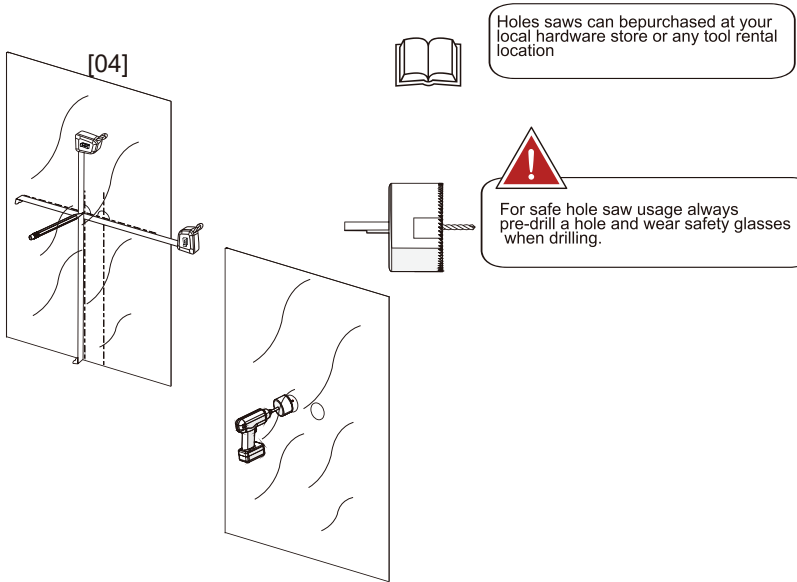
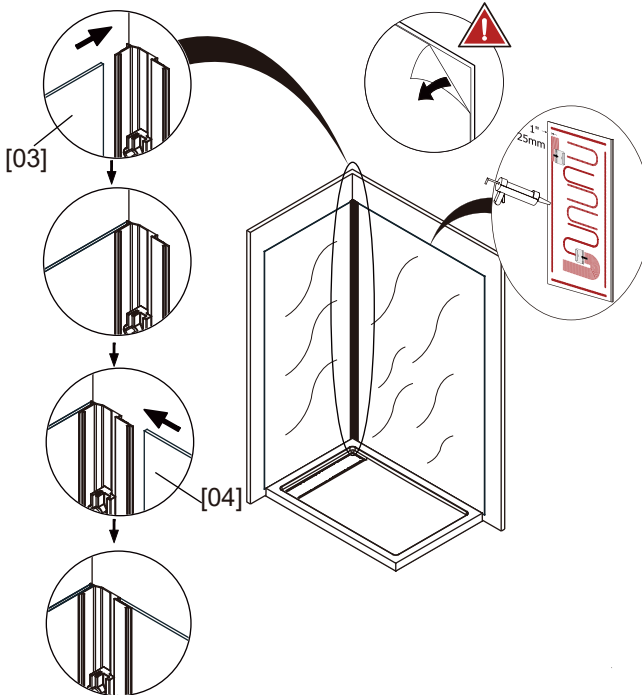
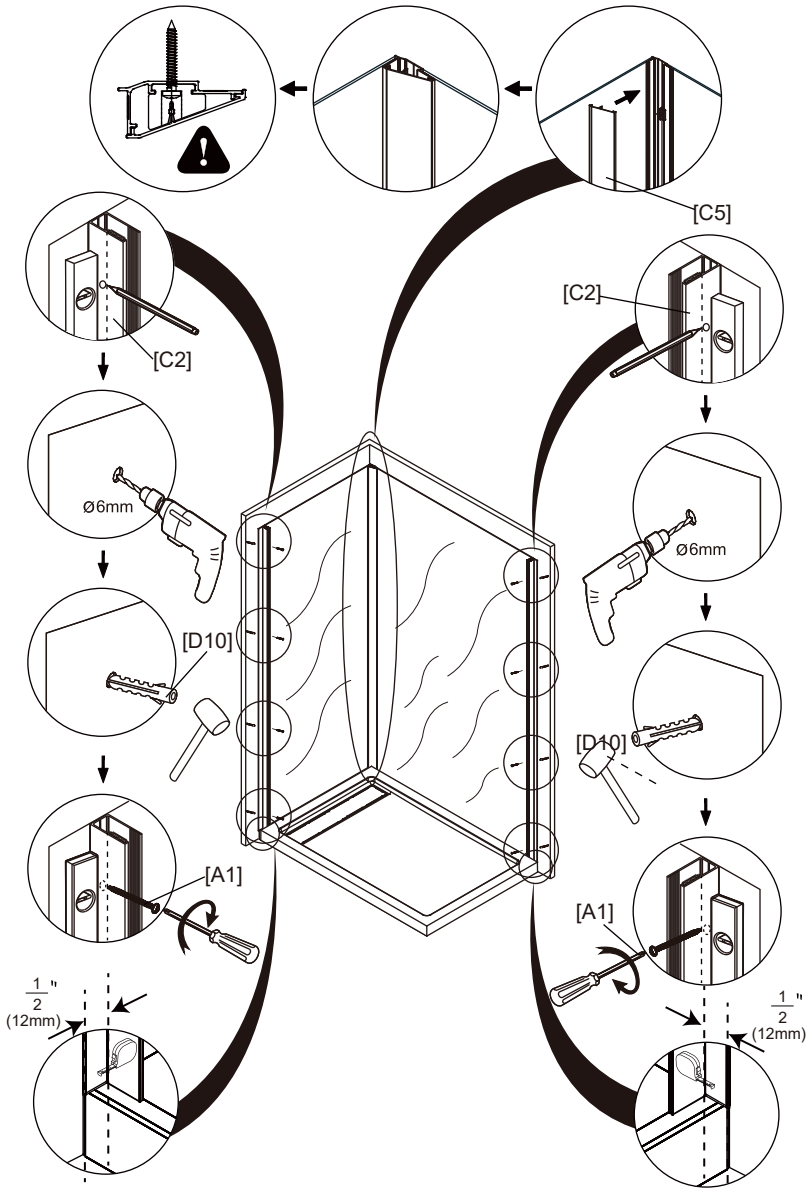

Fig.13



# Decorative column installation • Installation de la barre décorative

Fig.14



# Glass shelf installation

Fig.15

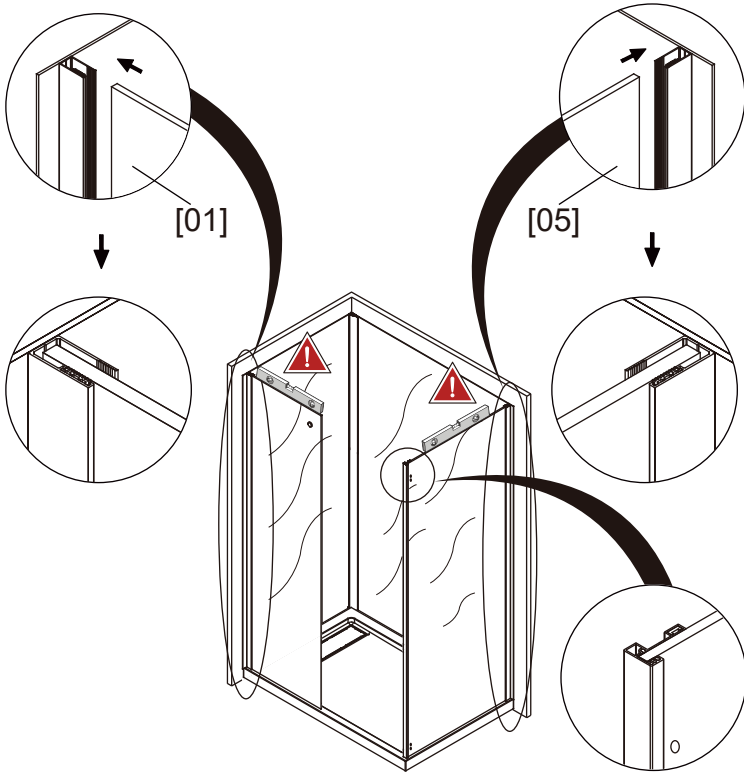

# Shower door Installation

Fig.16

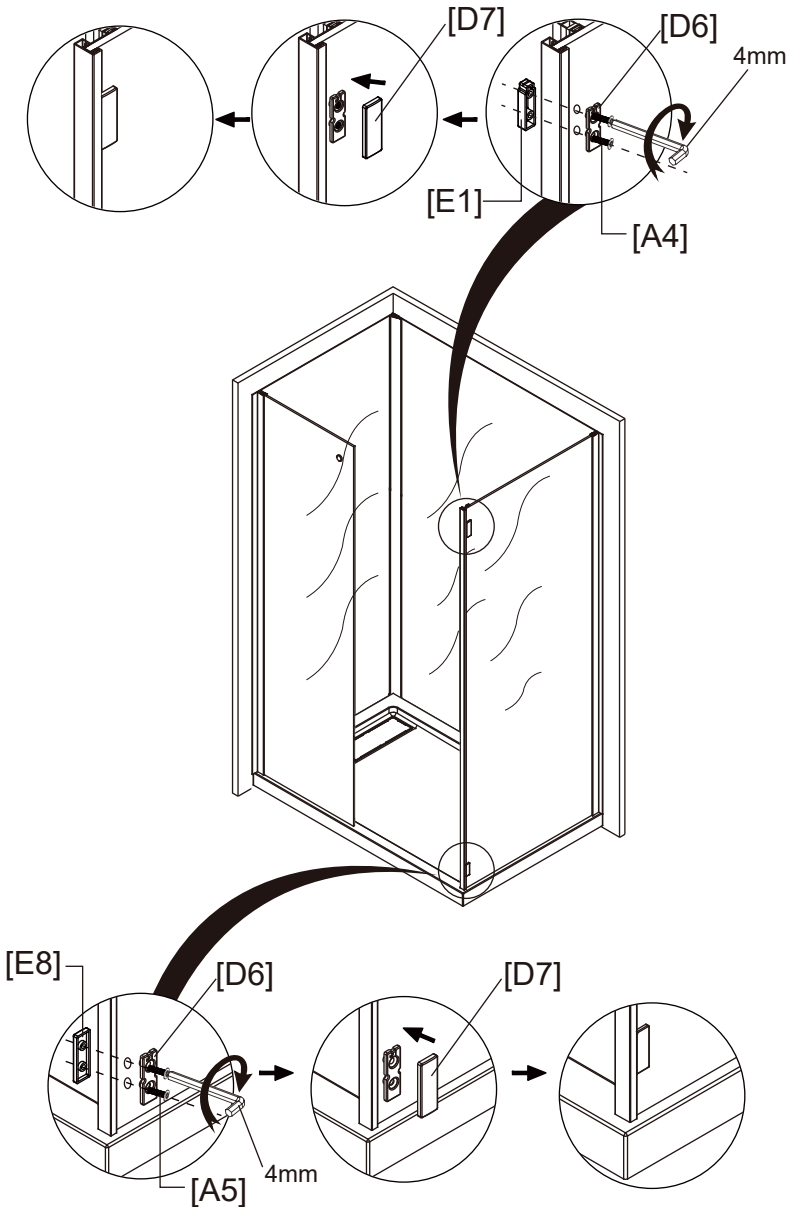

# Shower door Installation

Fig.17

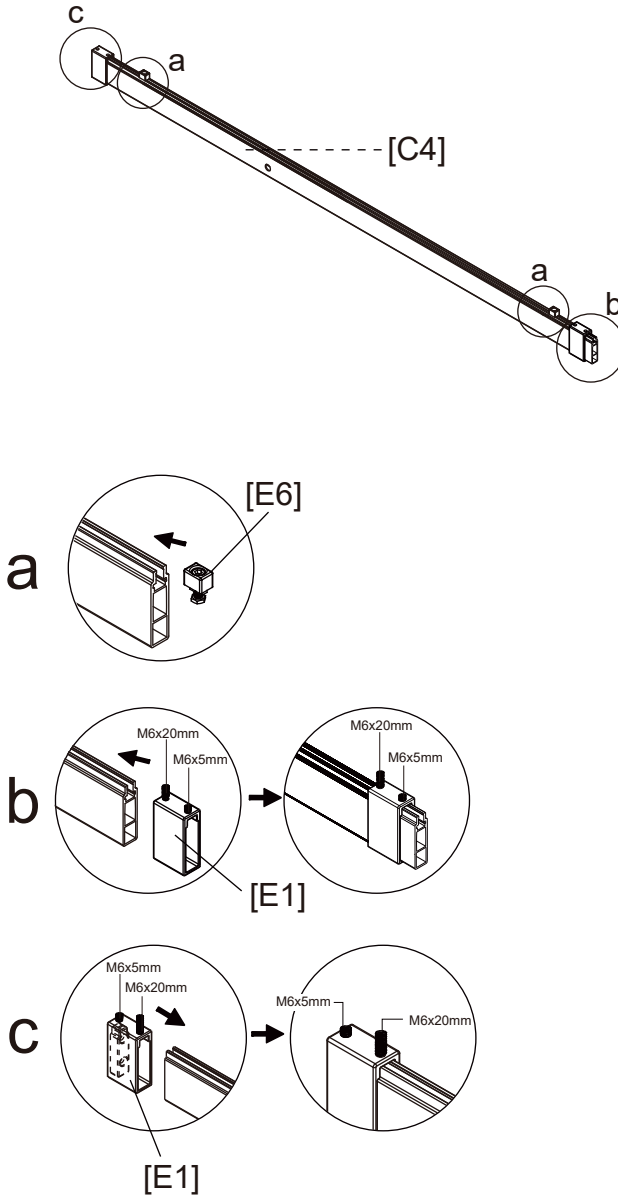

# Shower door Installation

Fig.18

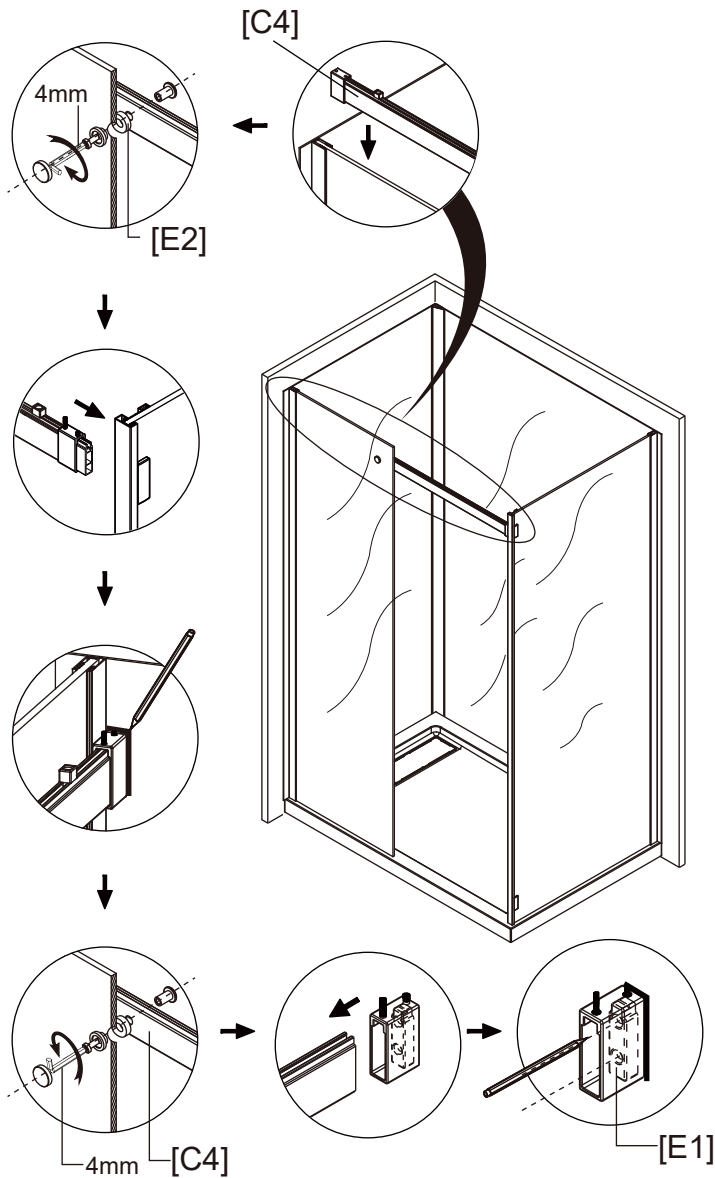



# Shower door Installation

Fig.19

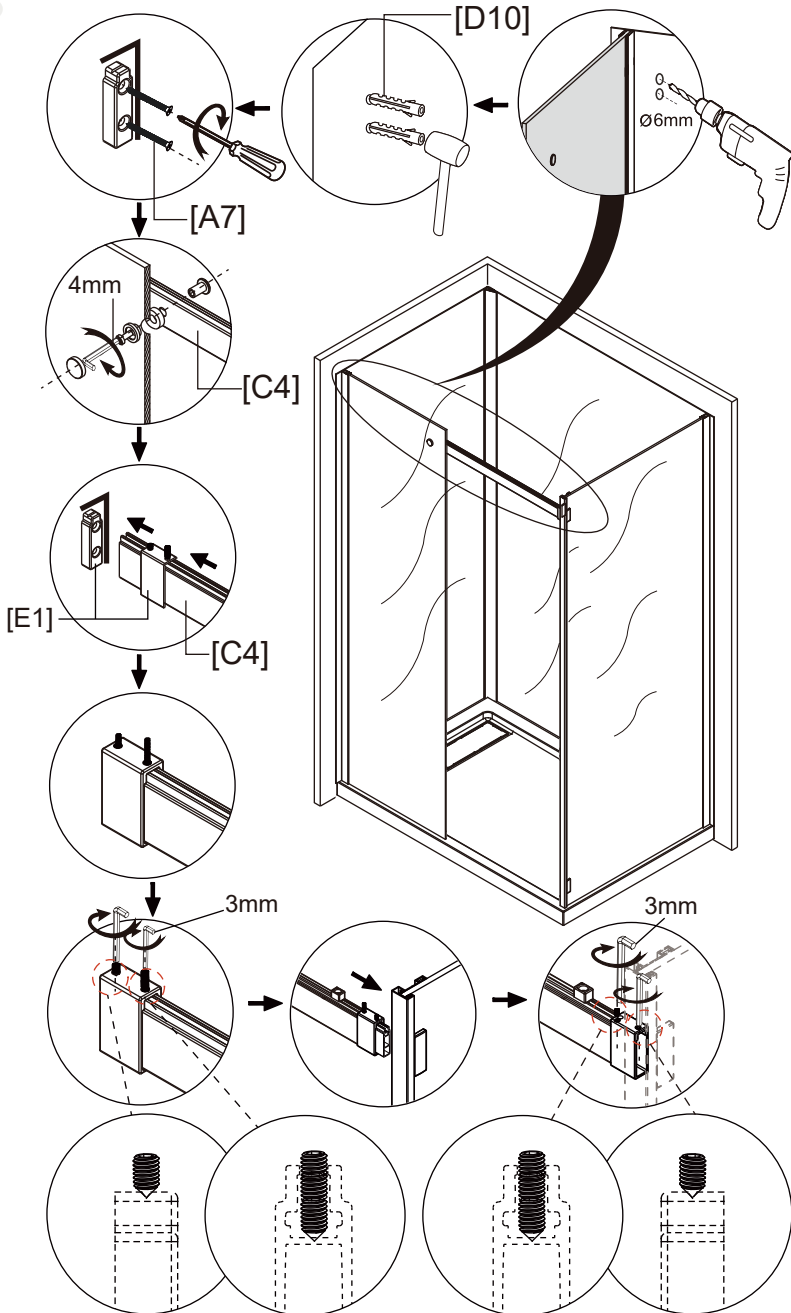

# Shower door Installation

Fig.20

Fig.20b

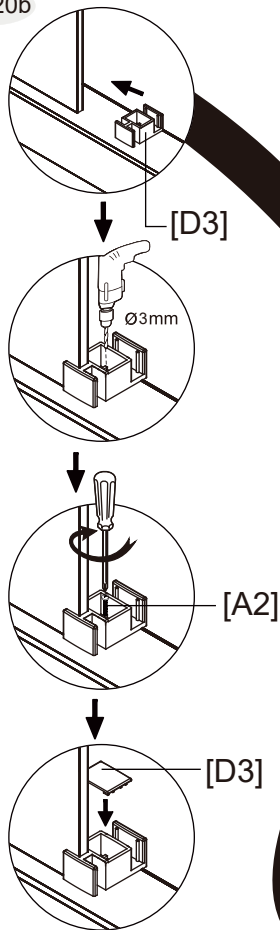

Fig.20a

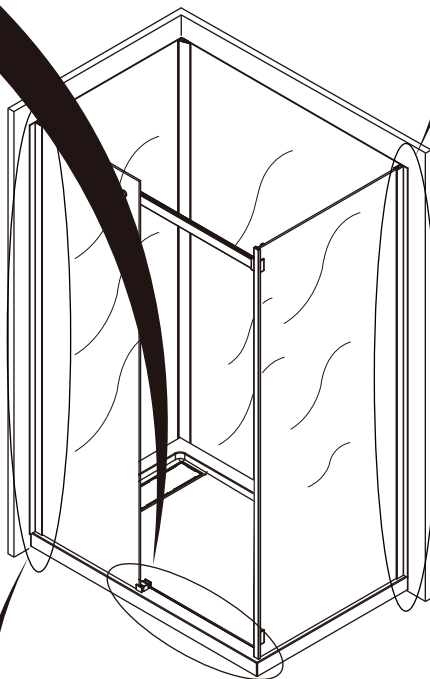
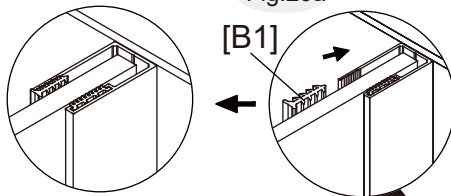
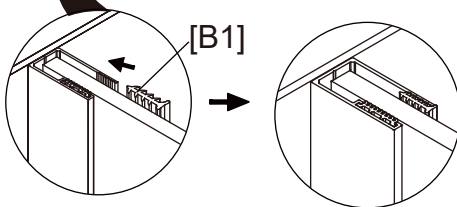
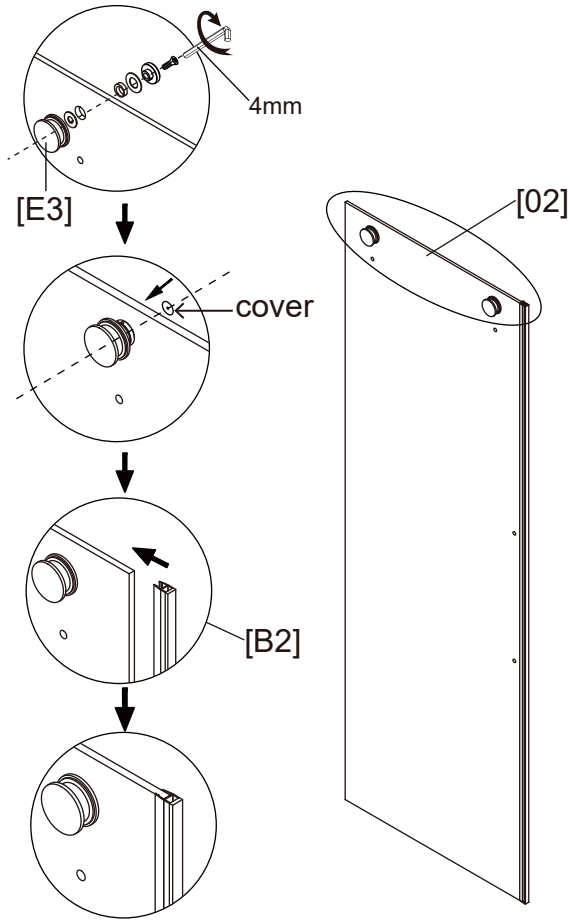

Fig.20a



# Shower door Installation

Fig.21



# Shower door Installation

Fig.22

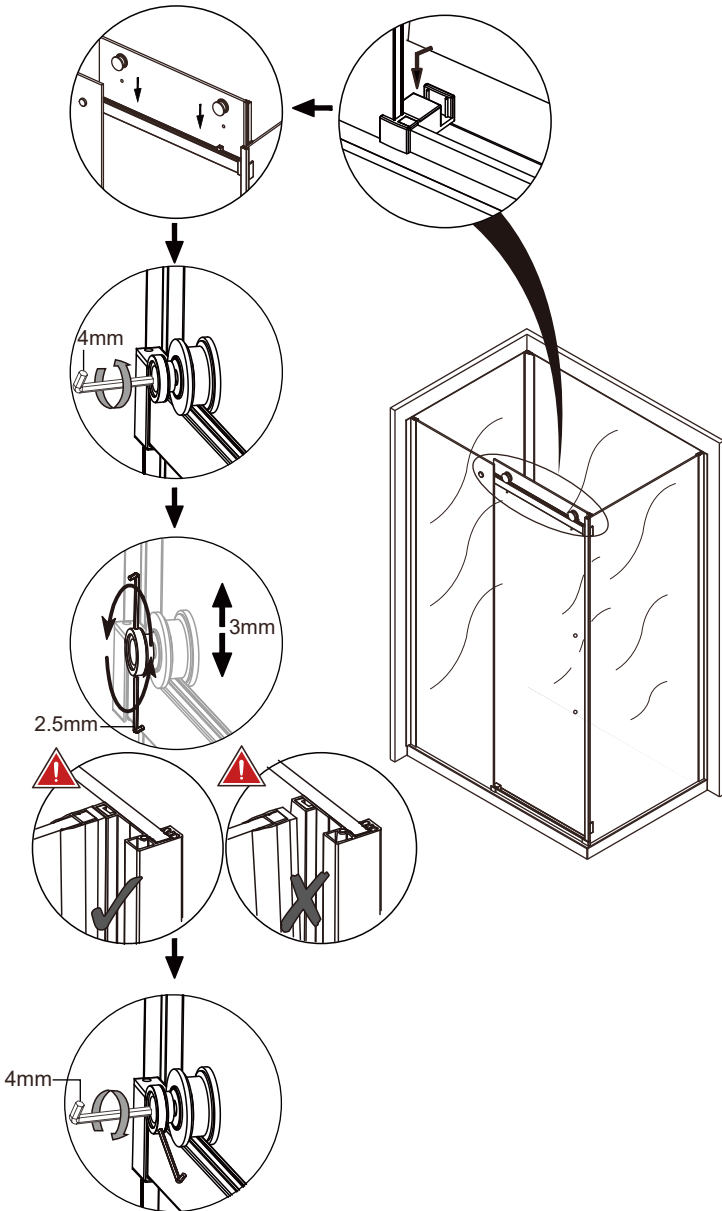

# Shower door Installation

Fig.23

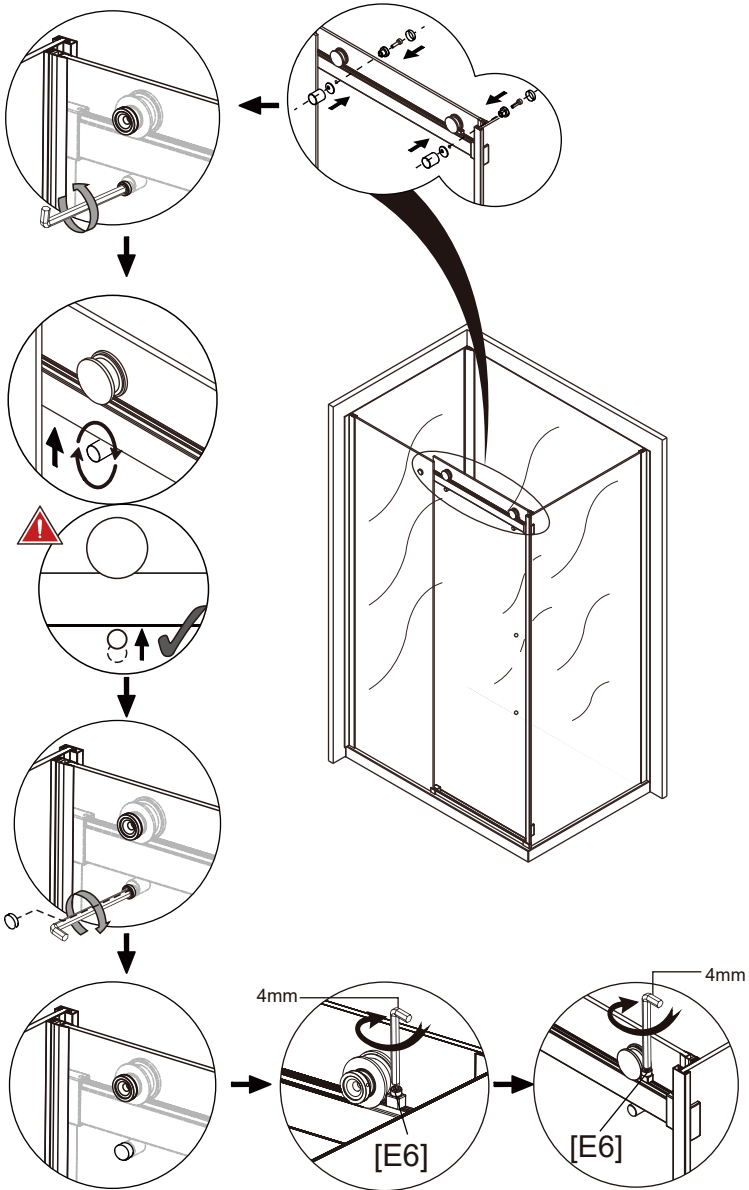

# Shower door Installation • Installation des portes de la douche

Fig.24

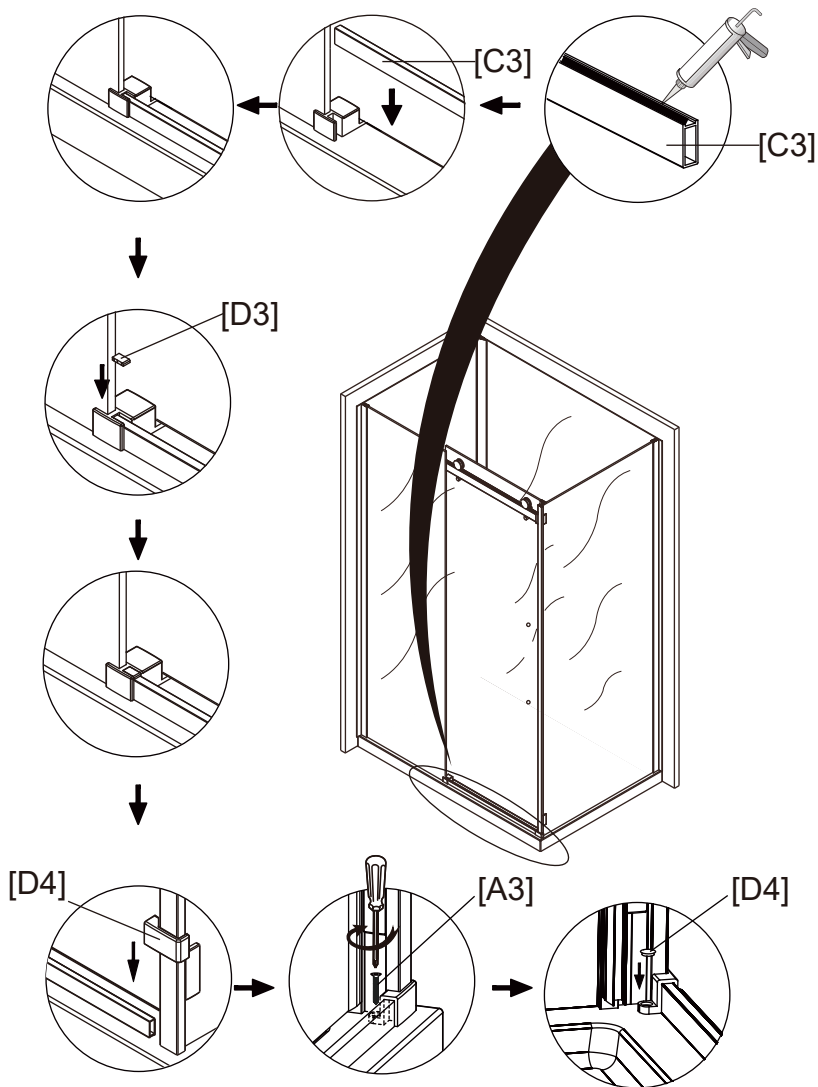

# Shower door Installation

Fig.25

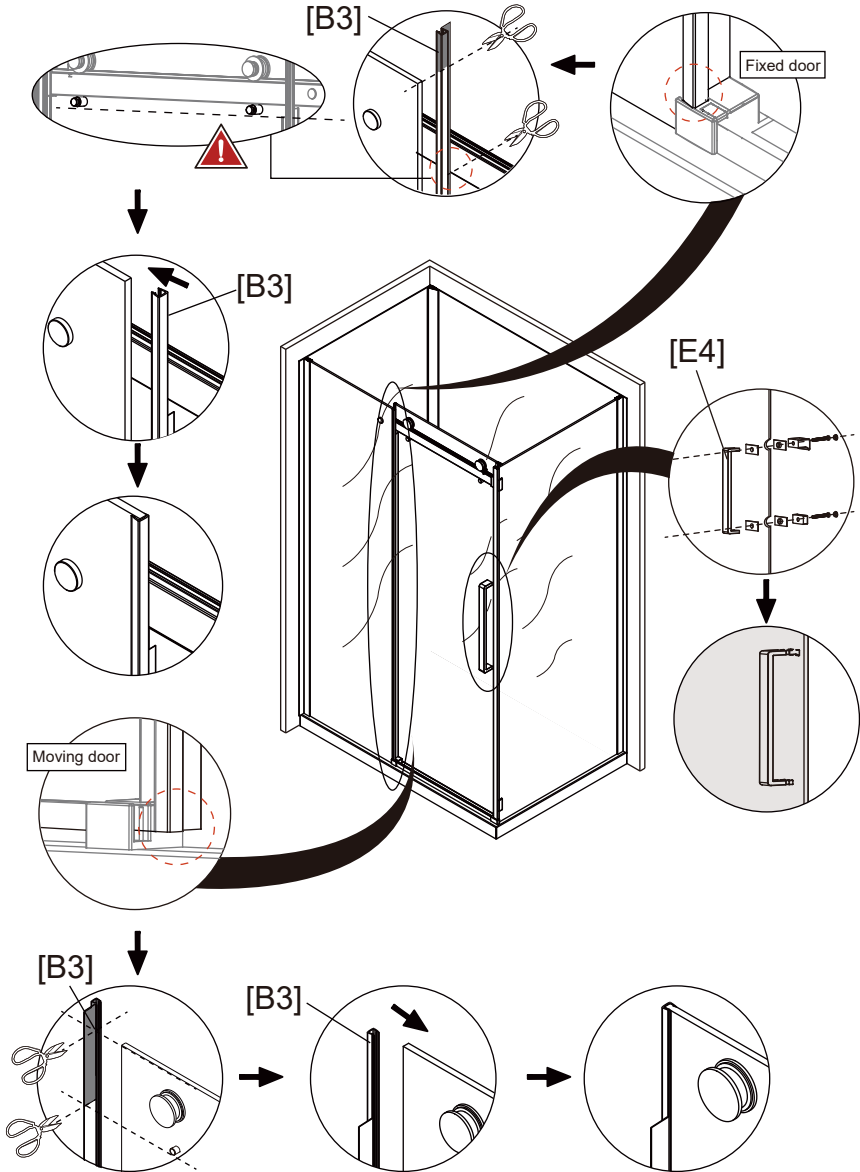

# Shower door Installation

Fig.26

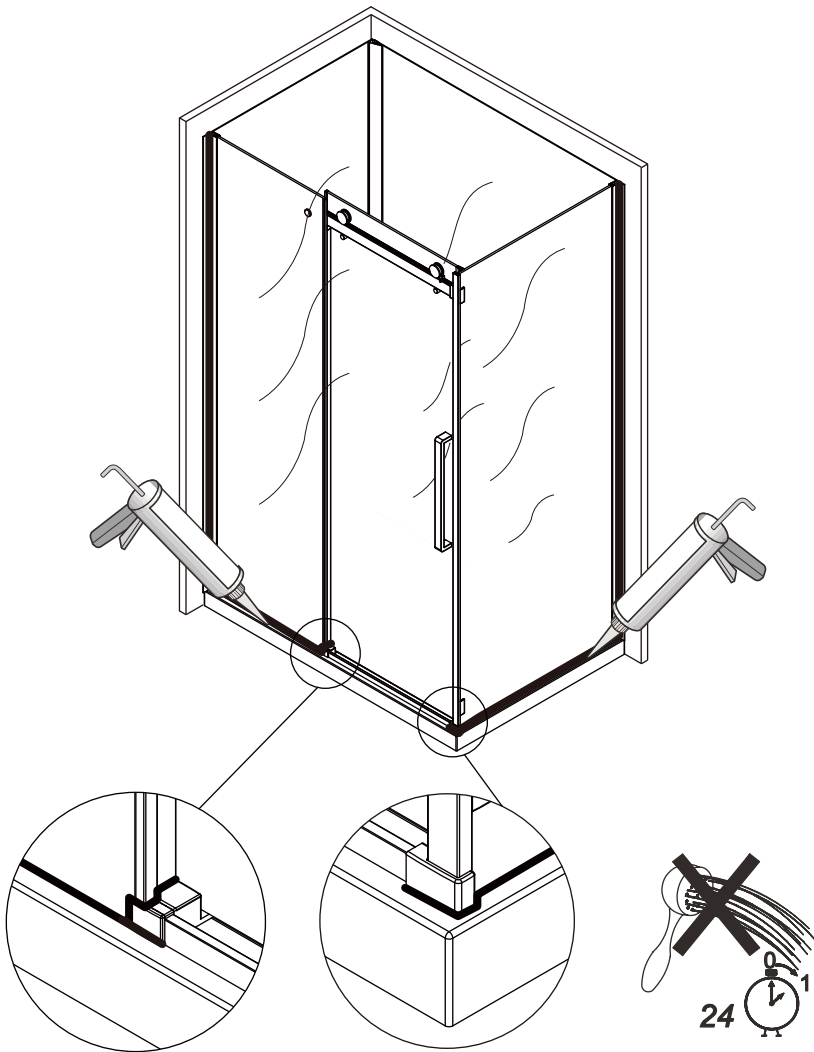



## Decorative column installation

B. Left to right opening

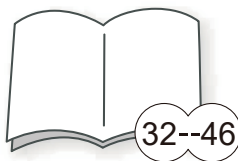
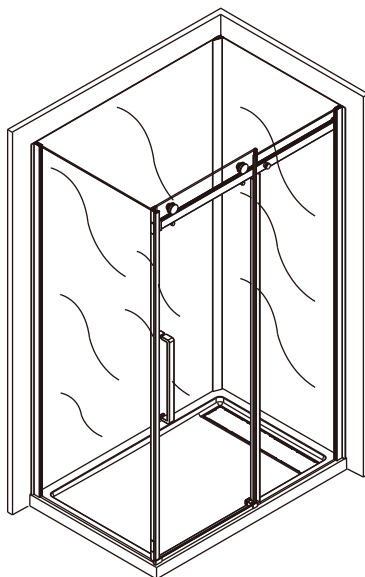

# Decorative column installation

Fig.12

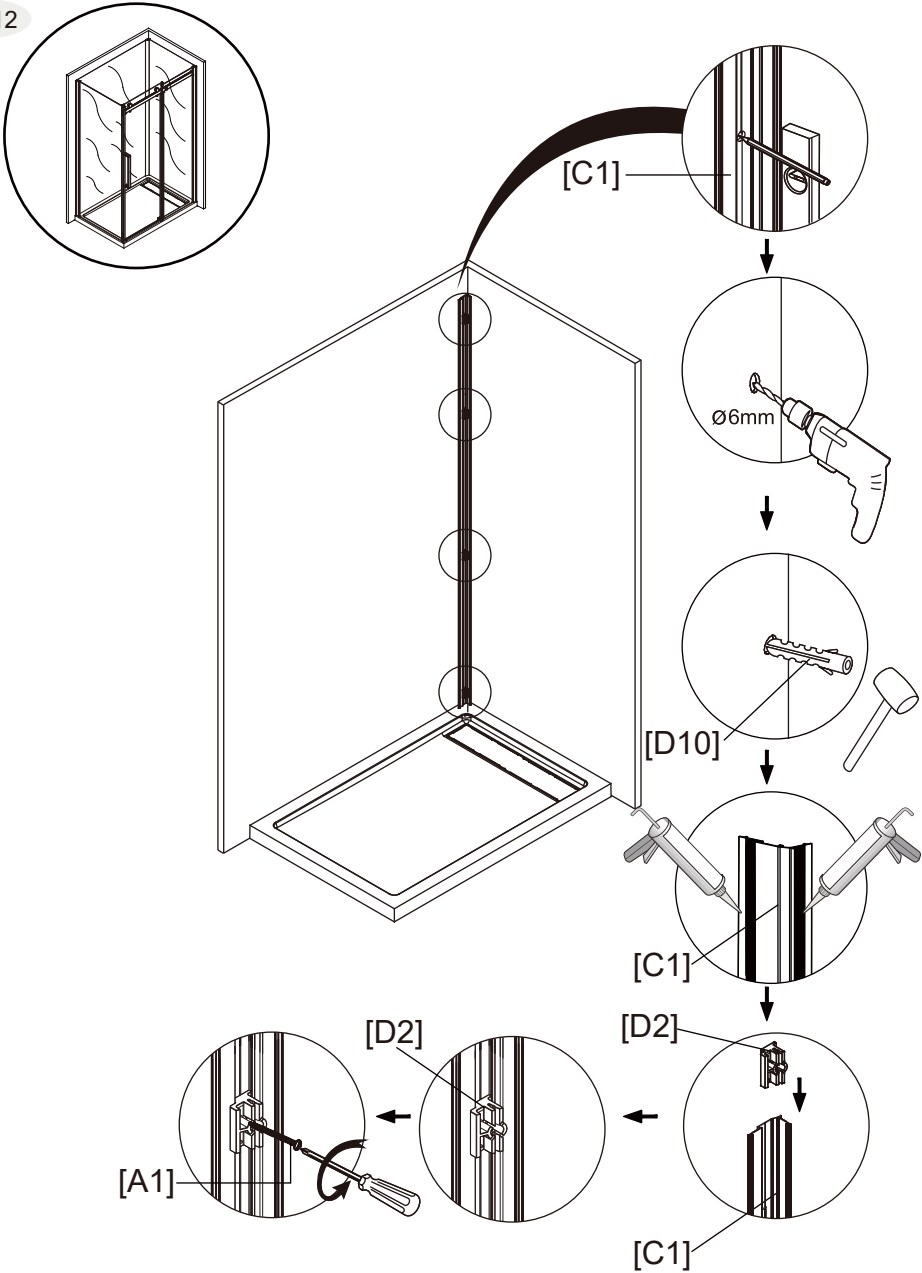

# Decorative column installation

Fig. 13a

Holes saws can be purchased at your local hardware store or any tool rental location



For safe hole saw usage always pre-drill a hole and wear safety glasses when drilling.

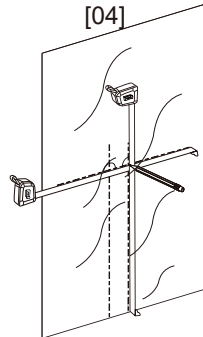
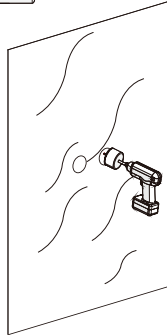
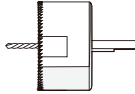
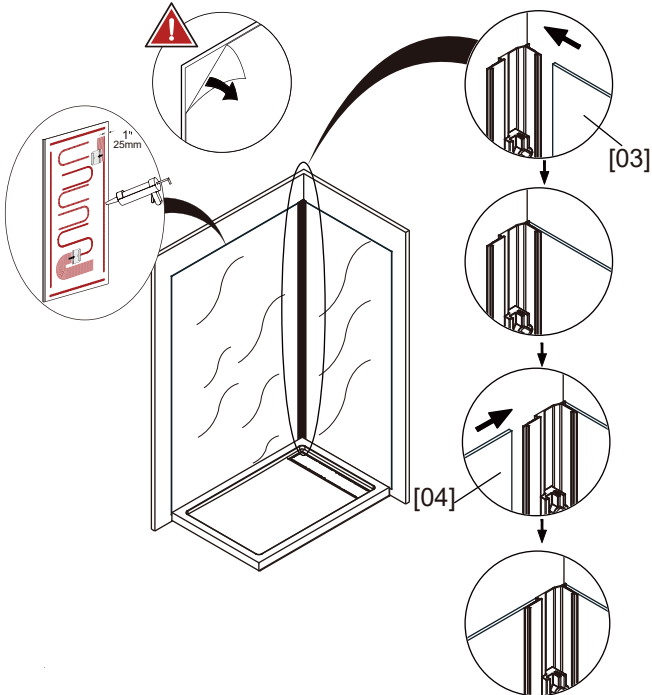
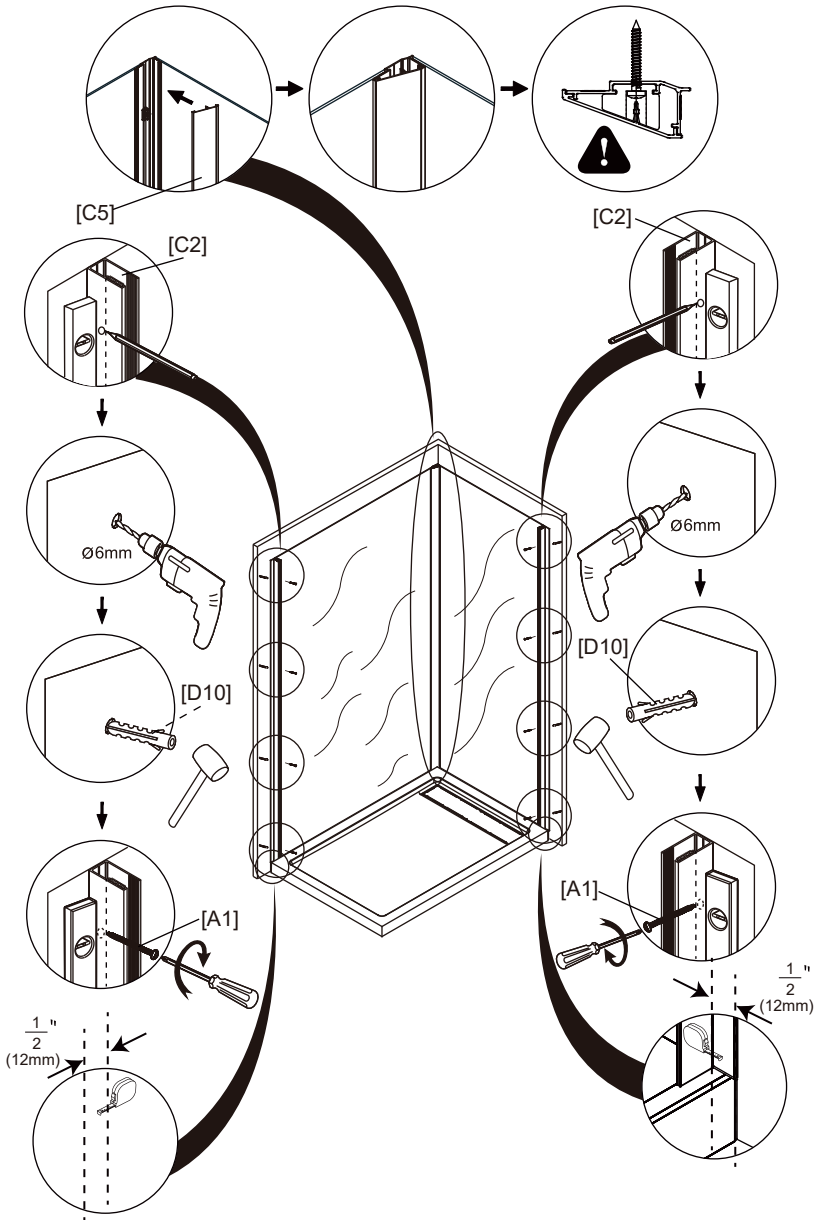

Fig. 13b



# Decorative column installation

Fig.14



# Glass shelf installation

Fig.15

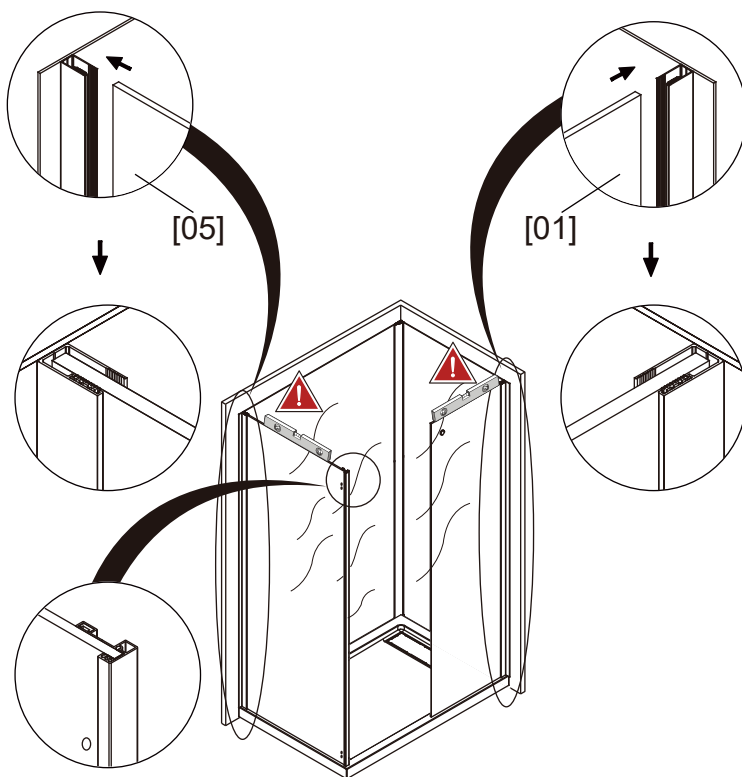

# Shower door Installation

Fig.16

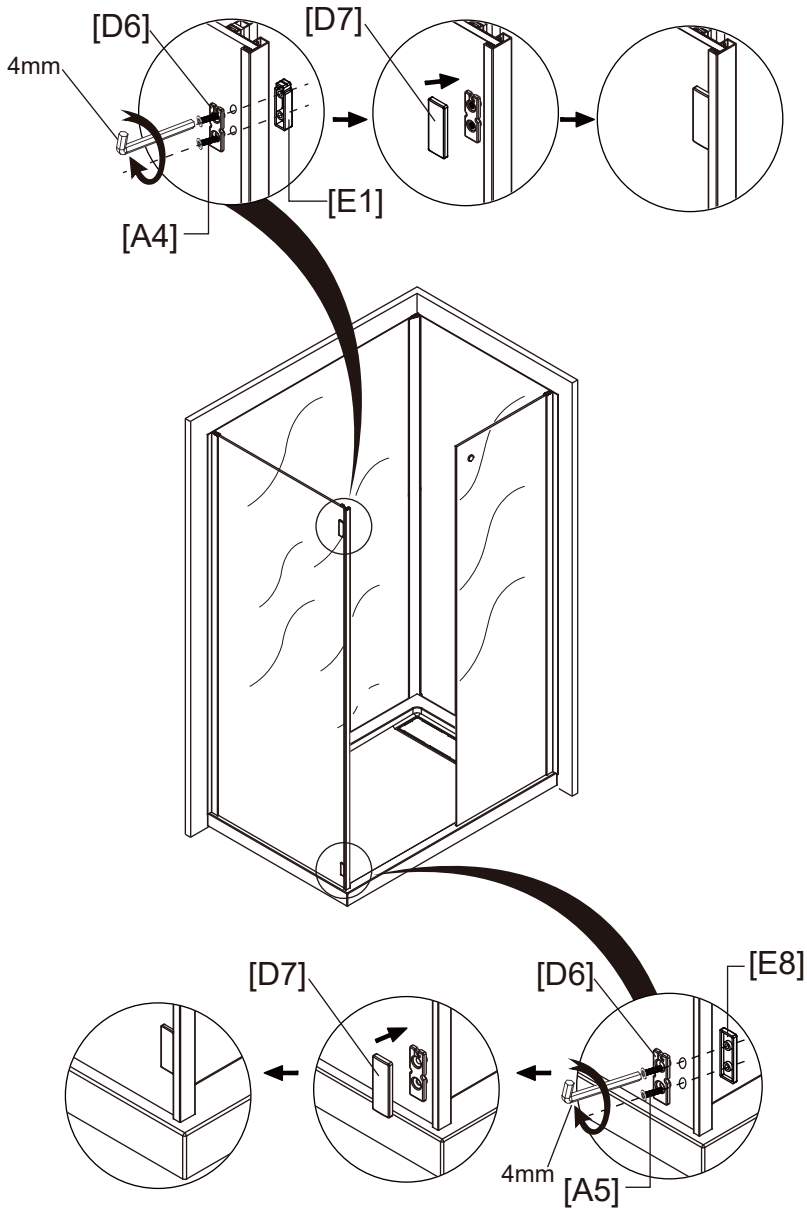

# Shower door Installation

Fig.17

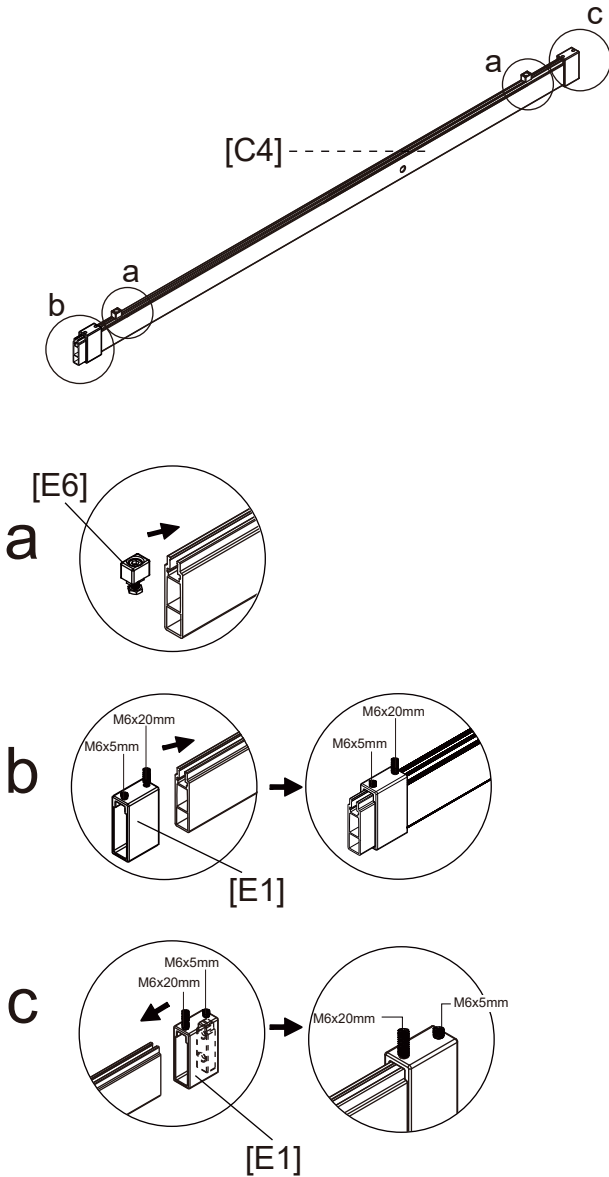

# Shower door Installation

Fig.18

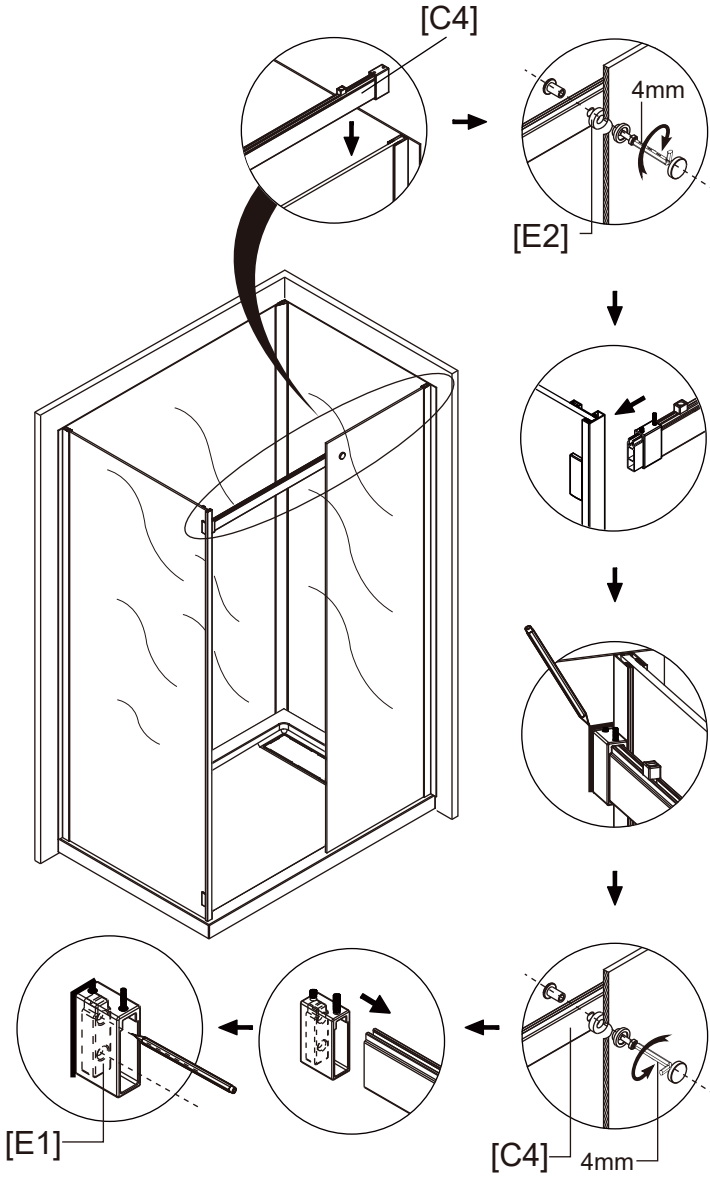



# Shower door Installation

Fig.19

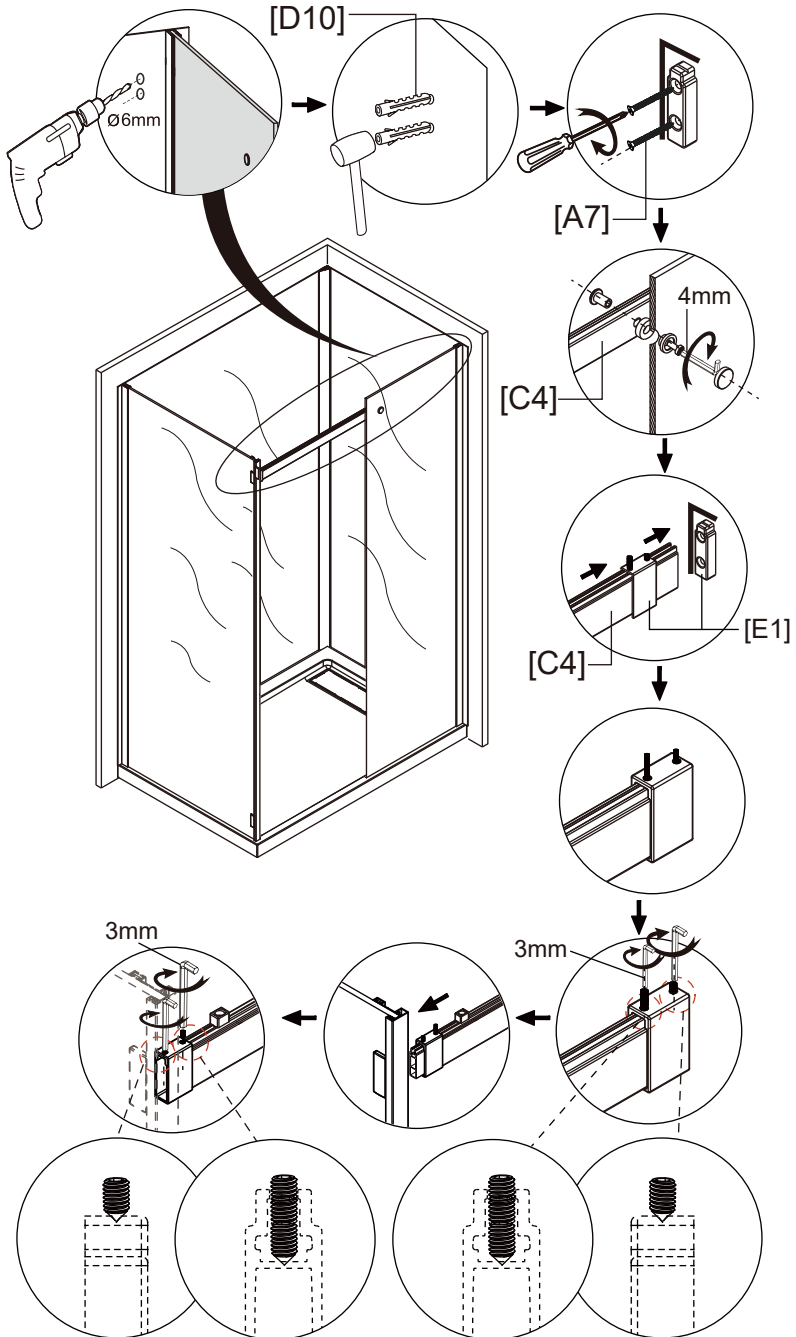

# Shower door Installation

Fig.20

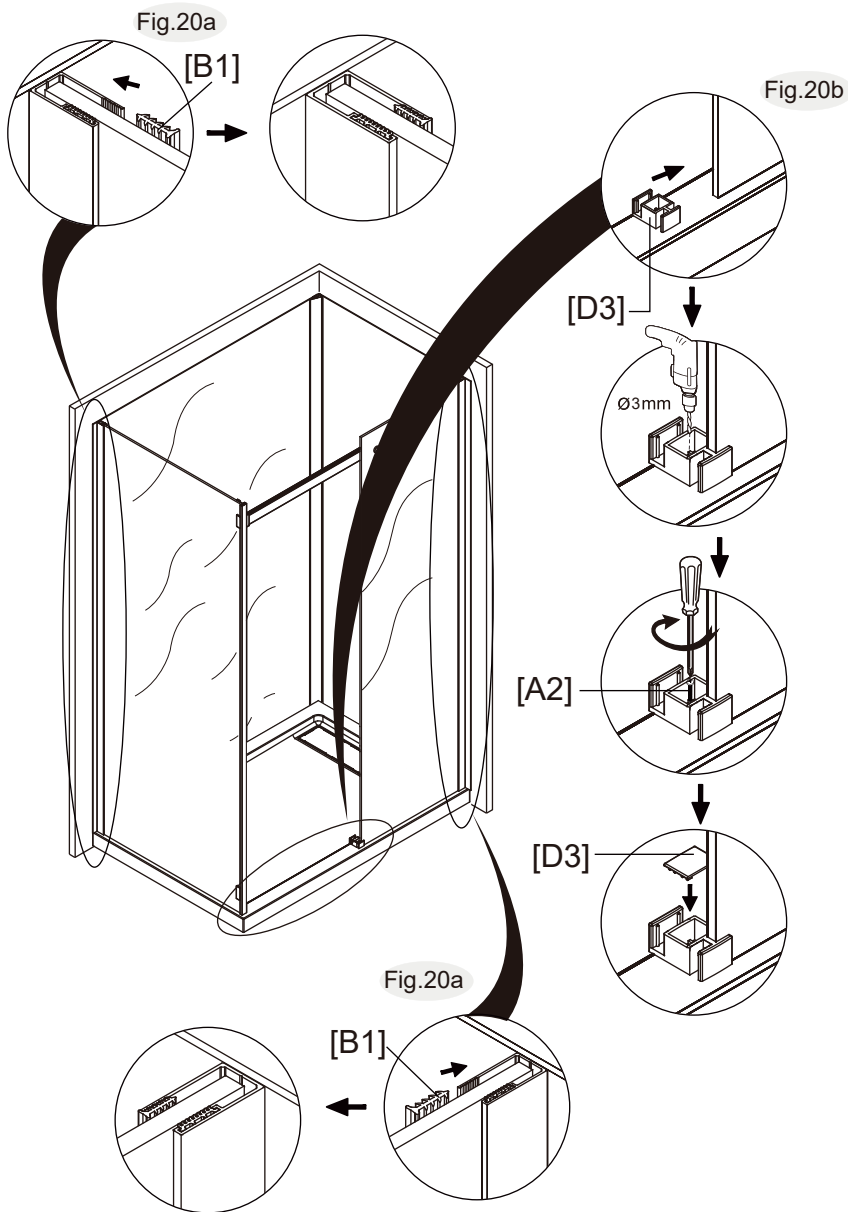

# Shower door Installation

Fig.21

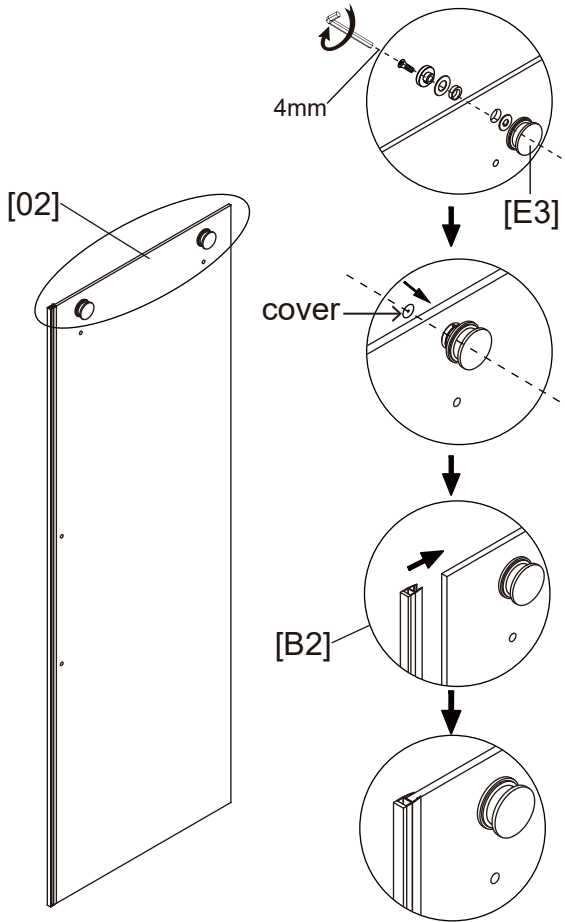

# Shower door Installation

Fig.22

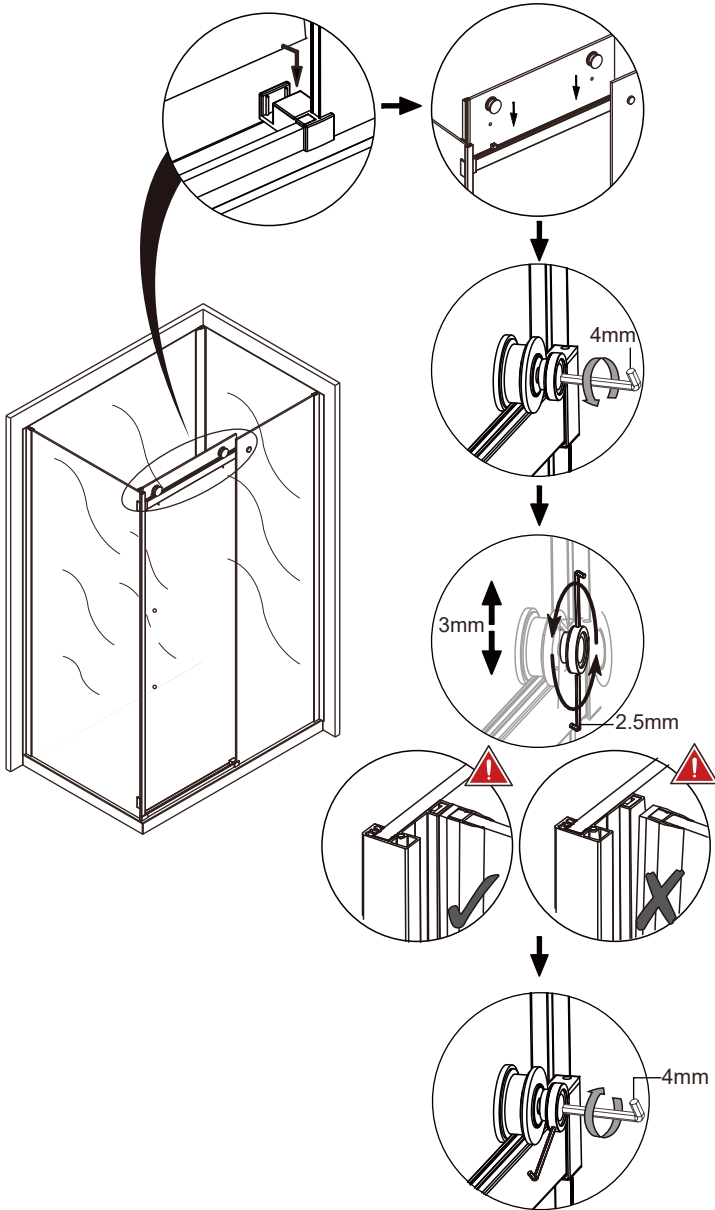



# Shower door Installation

Fig.24

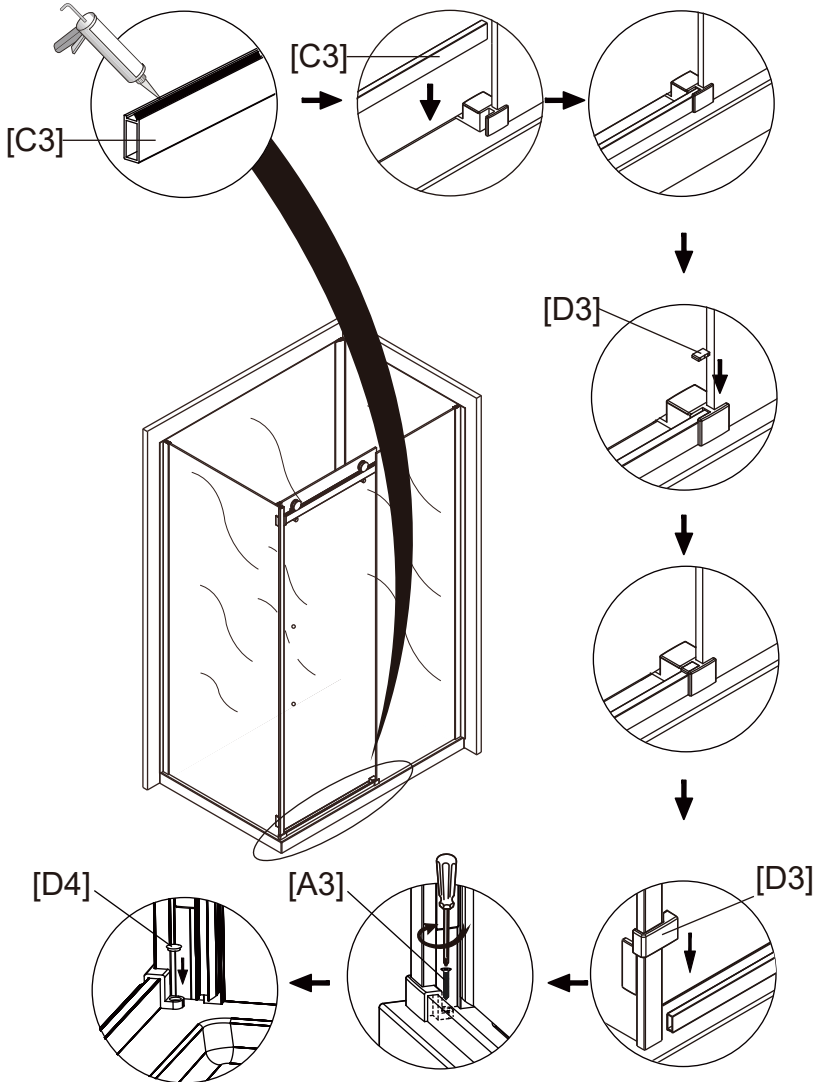

# Shower door Installation

Fig.25

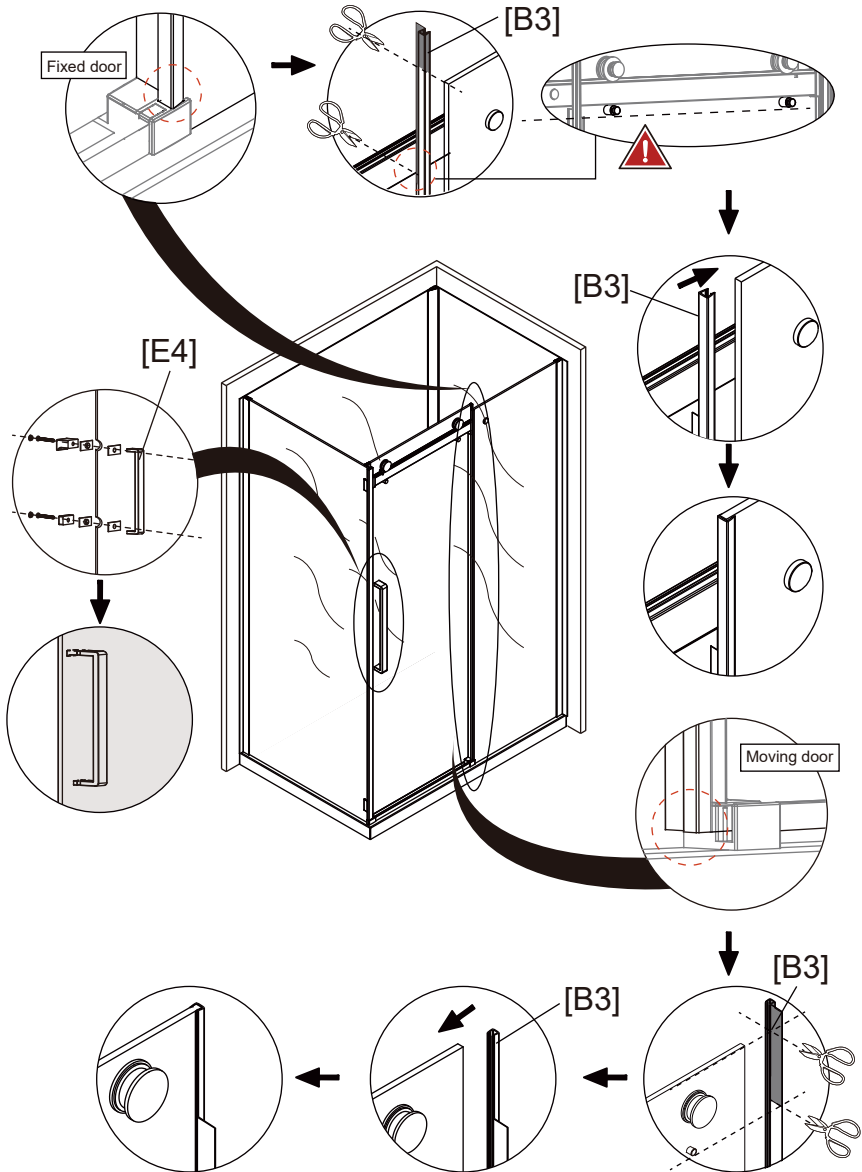

# Shower door Installation

Fig.26

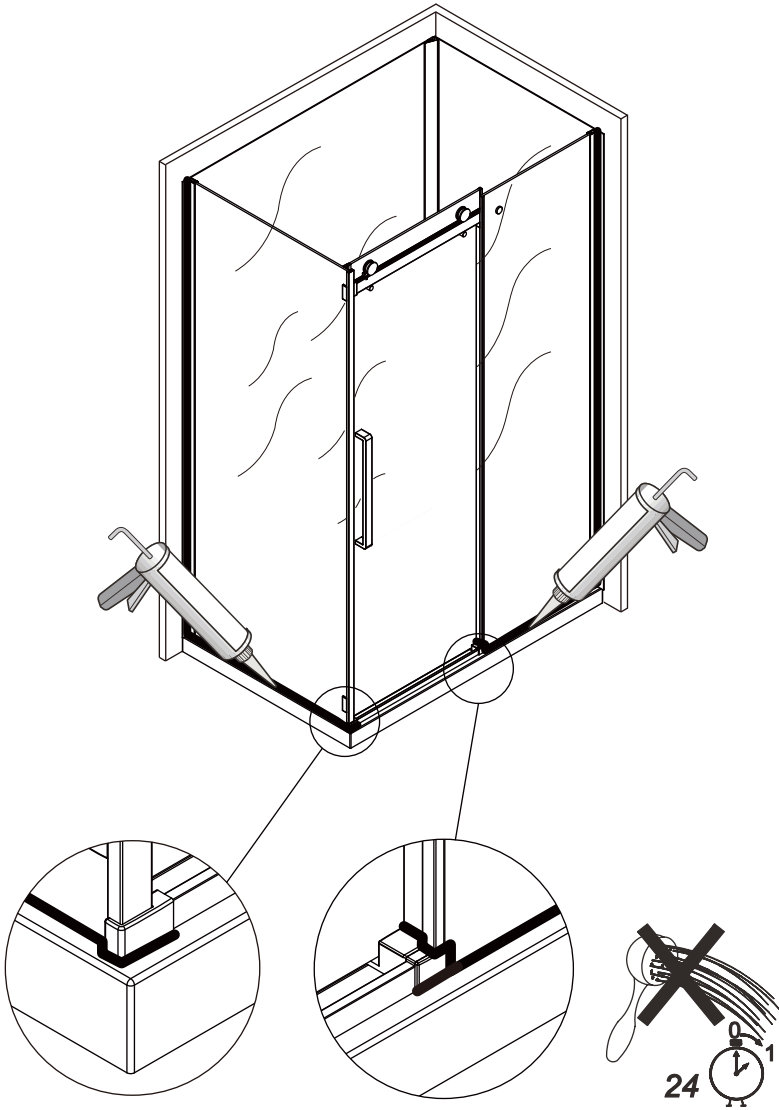





We certify that our products will meet your needs with their style, but also with their manufacturing quality. To make sure that they are reliable and safe, each product was carefully inspected, tested and approved during the quality control process that is in place.

### To whom does this warranty apply?

a **10-year limited warranty on shower bases and doors** from the date of purchase, exclusive to the first buyer as long as he/she resides in the same property. The warranty is intended for residential and/or domestic use.

### Care instructions

Clean the product with water and a mild detergent. Abrasive or corrosive cleaners, steel wool, acetone, dry cleaning products or ammonia compounds must never be used to clean the product. If a shower mat is used, it must be removed right after each use. We recommend the use of cleaning products that are made for acrylic specifically.

### What is covered by the warranty?

|                        | 1 Year*                                                        | 10 Years*                                            |
|------------------------|----------------------------------------------------------------|------------------------------------------------------|
| <b>Bases and walls</b> | Drain, drain cover, polypropylene and PVC                      | Acrylic and fiberglass against manufacturing defects |
| <b>Shower doors</b>    | Wheels, handles, diverter, screws, rails, towel bars and guide | Tempered glass                                       |

\*From the date of purchase.

Should there be any manufacturing defects that are not covered by the warranty, the product will need to be inspected prior to following through with the claim. Without that verification, the brand will assume no charge and/or responsibility.

### What are the exclusions?

The warranty doesn't apply if the product is damaged as a result of misuse, overuse or non-residential use, neglect, lack of maintenance, or the use of corrosive or abrasive products, regardless of the person who did those damages. The warranty does not cover shipping and labour costs. The warranty does not apply to the normal tear and wear of the goods.

The warranty doesn't cover the damages caused by the acts of God or breakage resulting from a shock or mishandling, regardless of the part played by the buyer or the installer. It also excludes the damages caused by an improper installation.

NADOLI doesn't cover damages caused by a water leak, even if they result directly or indirectly from a product defect, except where the applicable legislation does not allow any exclusion or limitation following indirect or consequential damages.

It is fair to say that if the product has a manufacturing defect, it will show as soon as it is installed or shortly after. However, a leak caused by an improper installation could happen a long time after. Therefore, it is strongly advised to have it done by a professional.

**All warranty claims must include the invoice copy.**

**Should a part or product component be defective or the finish damaged following a normal domestic and residential use, NADOLI commits to replacing the defective part(s) to the first buyer only. NADOLI could also, in its sole discretion, commit to offer a full replacement. No indemnity shall be claimed for loss of enjoyment of life, loss of income or losses caused by water.**