

Installation Instructions for Shower kit

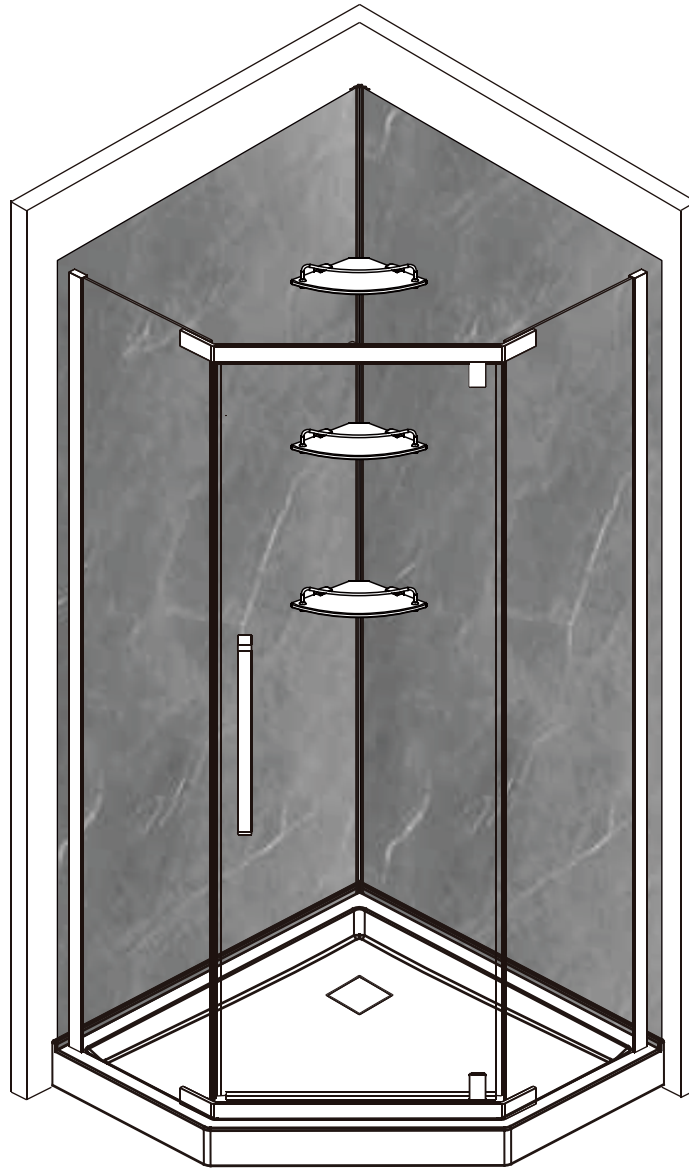

Model : DK1136CC / DK1136CB

Barcode : 0655343467562 / 0655343467555

Read all instructions carefully before proceeding.

SAVE THIS GUIDE FOR FUTURE REFERENCE.



◆ General Information

Please inspect the product immediately upon receipt for transit damage, missing packs / parts or manufacturing defects. Damage reported later cannot be accepted. Please handle the product with care to avoid knocks and shocks on any side or edge of the glass.

Note: The safety glass cannot be re-worked.

Please read these instructions carefully before starting the installation.

Special care should be taken when drilling the walls to avoid hidden pipes or electrical cables.

Aftercare Instructions

After use, your shower should be cleaned with soap and water. This is particularly important in hard water districts where insoluble lime salts may be deposited and allowed to build up. Gritty or abrasive cleaners should not be used. Avoid contact with strong chemicals such as organic solvents and strippers. Glass cleaners can be used but with caution. If in doubt, contact the cleaner's manufacturer.

Please keep these instructions for aftercare and customer service details.

~~~~~

## Tools Required

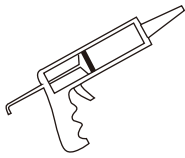

Silicone

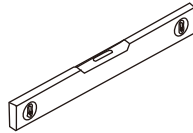

Level

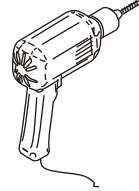

Electric drill



Hammer

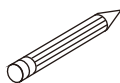

Marker

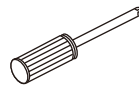

Screwdriver

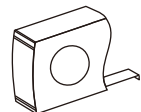

Measuring Tape



**Note:**

This product is heavy and may require two people to install.

# Parts and components

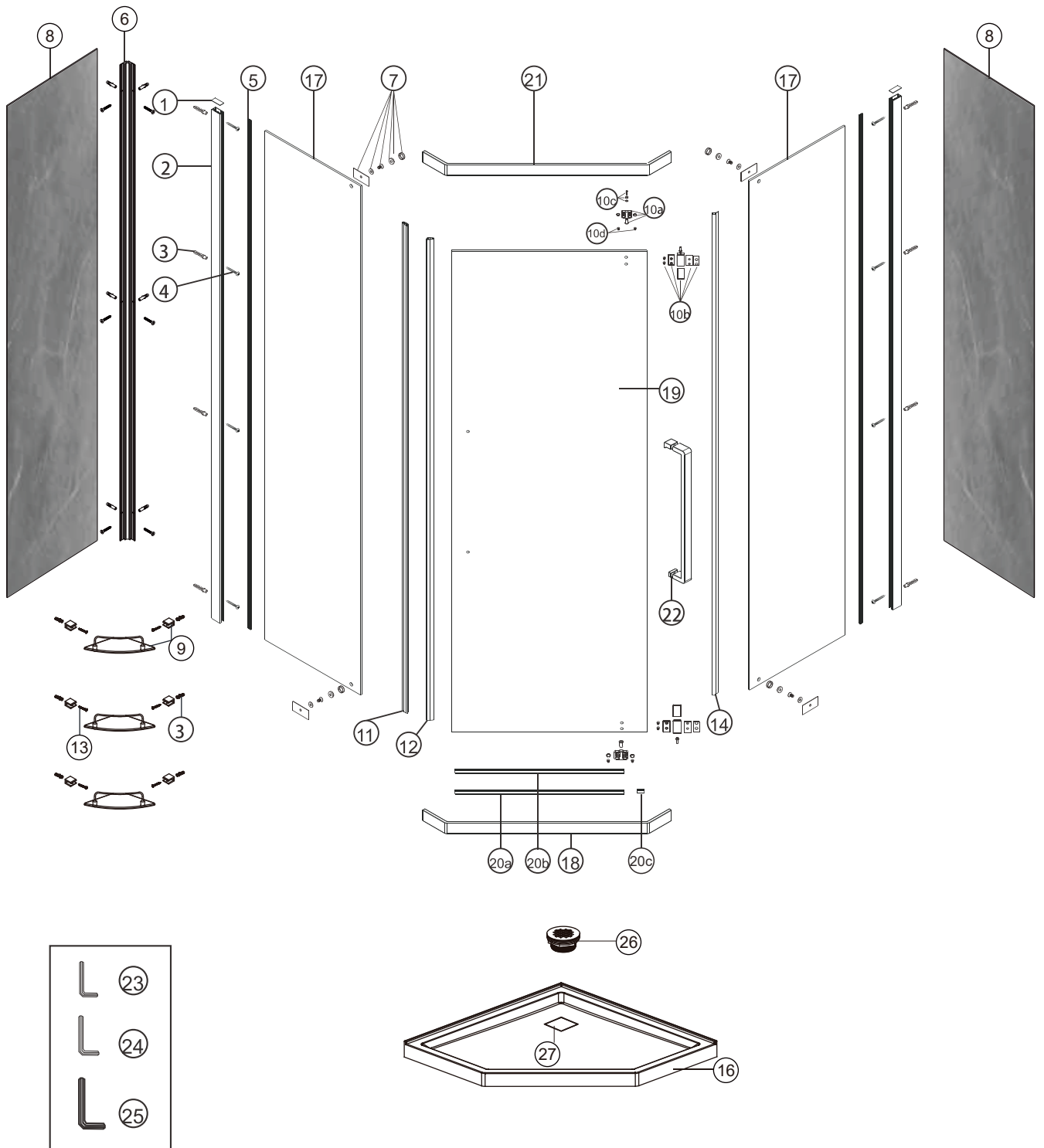

# Preparation of the shower installation area

Fig.1

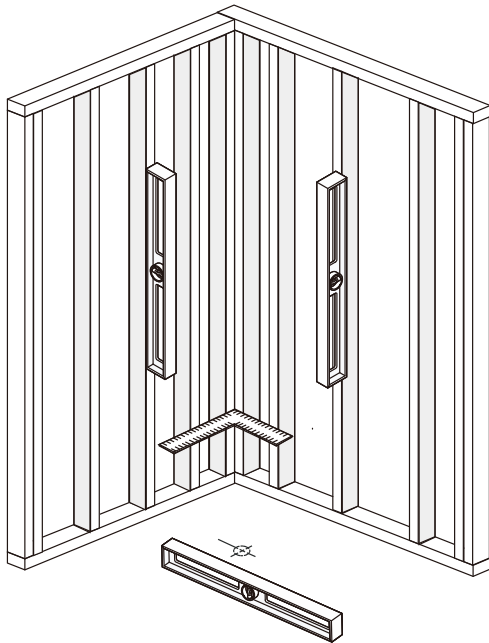

**Fig.1** For a new construction and whenever possible in the case of a renovation, install an extra stud in each wall. Each stud has to be at a distance of 36" (914mm) from the wall's corner. Fig. 1

**Fig.1a** For the stud distribution, please refer to Fig. 1a and Fig. 1b.

Fig.1a

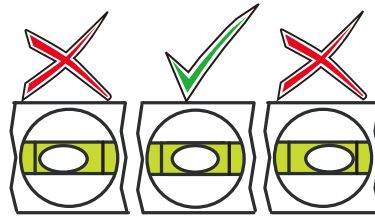
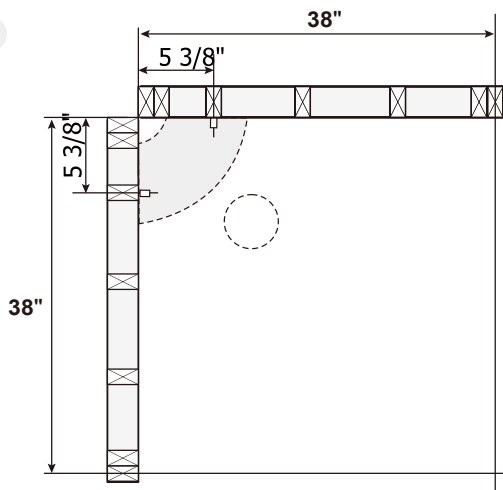

 Leveling the floor is critical for the wall alignment.



To level the floor, use a self-leveling mortar.

Fig.1b

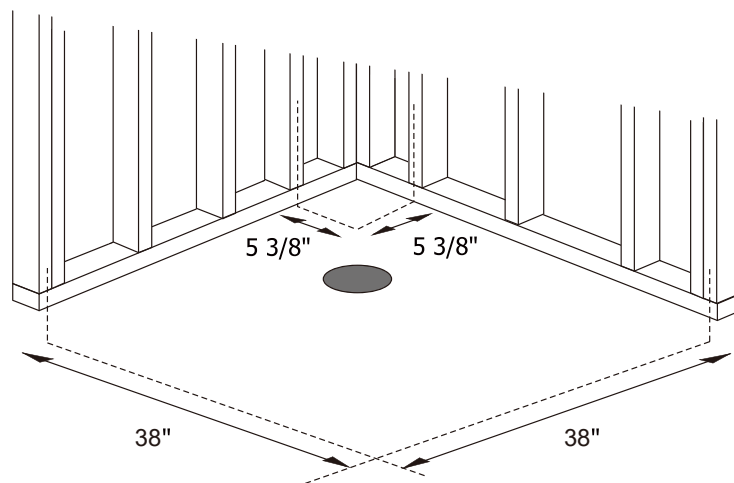

## Preparation of the shower installation area

Fig.2

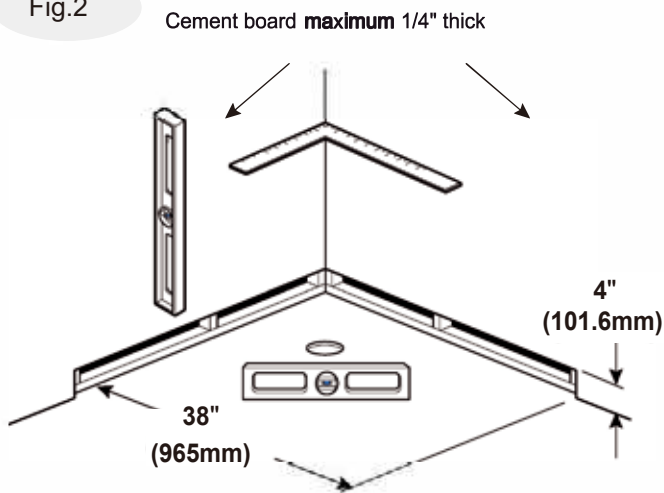

Note: The base has to be installed against the studs - not the finished walls. The finished walls must not exceed 1/4" thick. If necessary, remove the wall covering to expose the studs. Fig. 2.

Confirm that the walls are vertical using a plumb line within 3/8" square, and that the floor is level. Fig. 2.

Fig.3

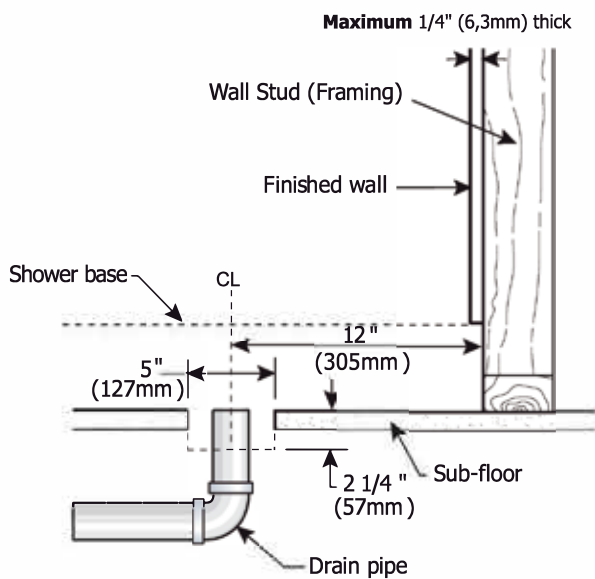

**Fig.3** To compensate for any irregularities on the floor, the base must be shimmed properly from underneath in order to provide a level threshold for mounting purposes. All shims must support the entire base, not just a part of it. To make sure, stand on the base once it is shimmed and check for any spring or bounce in the base, particularly near the drain area.

Before the final installation - wedge retainer insertion (Fig. 4) - make sure that the base is level and that water drains away properly. Use some tape around the drain to seal it temporarily and pour 1-2 cups of water around the extremities of the tray to test the drainage.

# Preparation of shower area

Fig.4

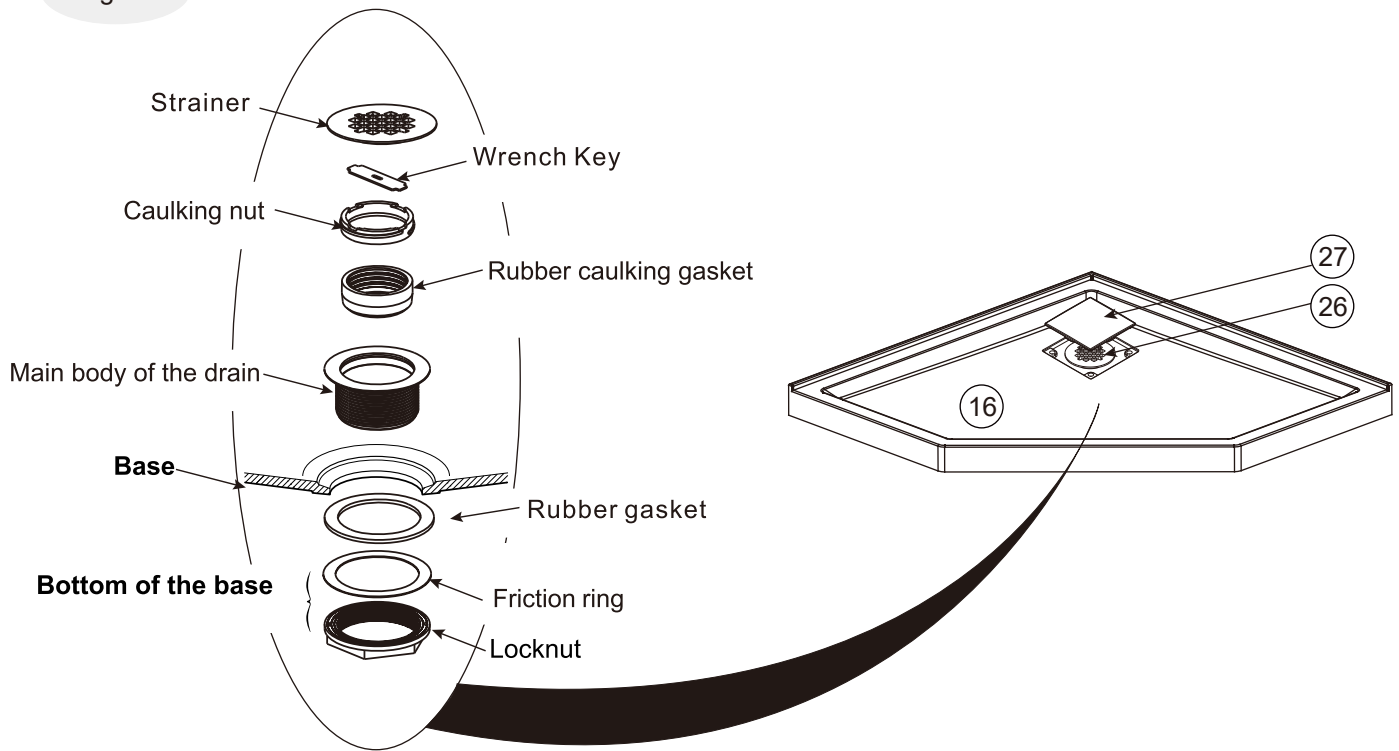
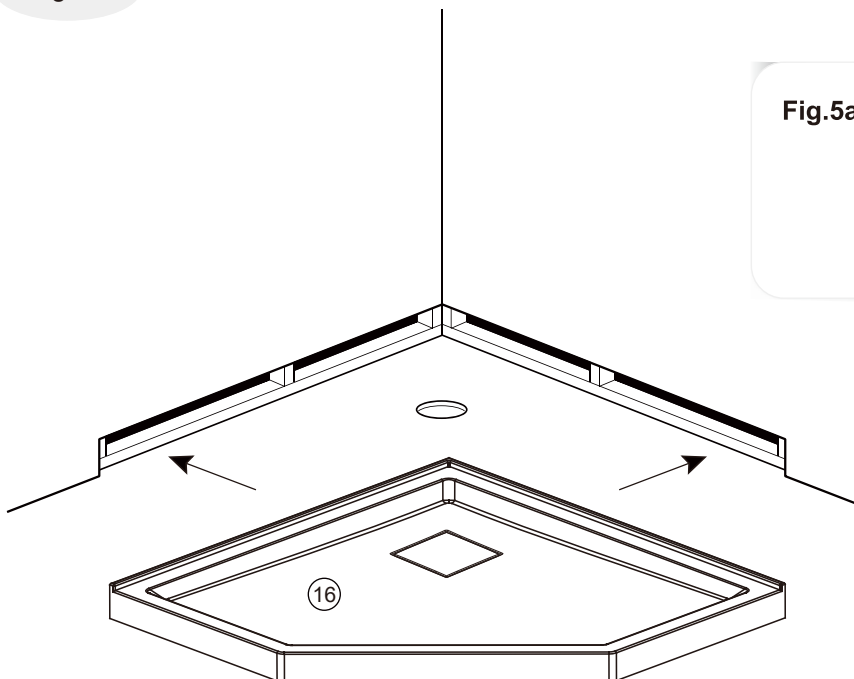

Fig.5



**Fig.5a** Install the base directly against the studs and make sure that the drain pipe is centered with the drain head. The base has to be leveled in all directions. Please refer to the drain installation guide.

# Base installation

Fig.6

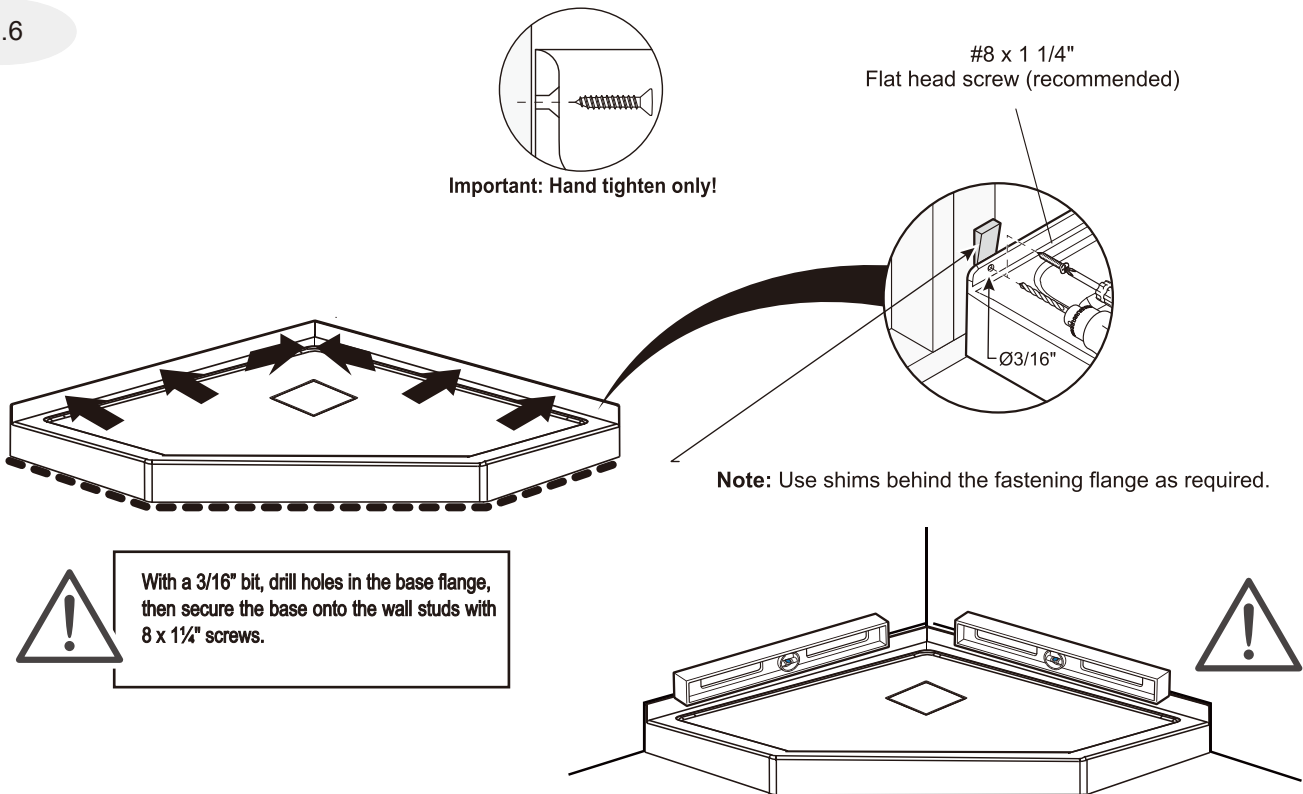
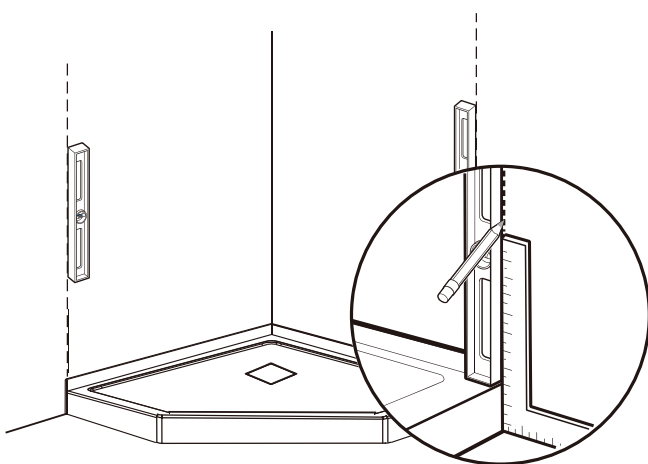

Fig.7



**Note: The wall panels should be installed at a temperature near 16 °C (60 °F) and must not be installed in unheated areas where temperatures might drop below 0 °C (32 °F).**

The wall panels can be installed over drywalls, plaster, painted walls, plywood or ceramic tiles. Wall surfaces must be solid, dry, clean and smooth. Scrape off any loose paint, wallpaper or plaster. It is strongly recommended that raw plaster or new wallboard be primed or water-sealed prior to installation.

If the panels are being installed over existing tile that has been over 30% removed during the wall preparation, it is recommended that the remaining tiles also be removed. Existing ceramic tile should be slightly sanded. Draw the vertical alignment from the edge of the shower base on each side (Fig. 6).

# Shower door Installation

Fig.8

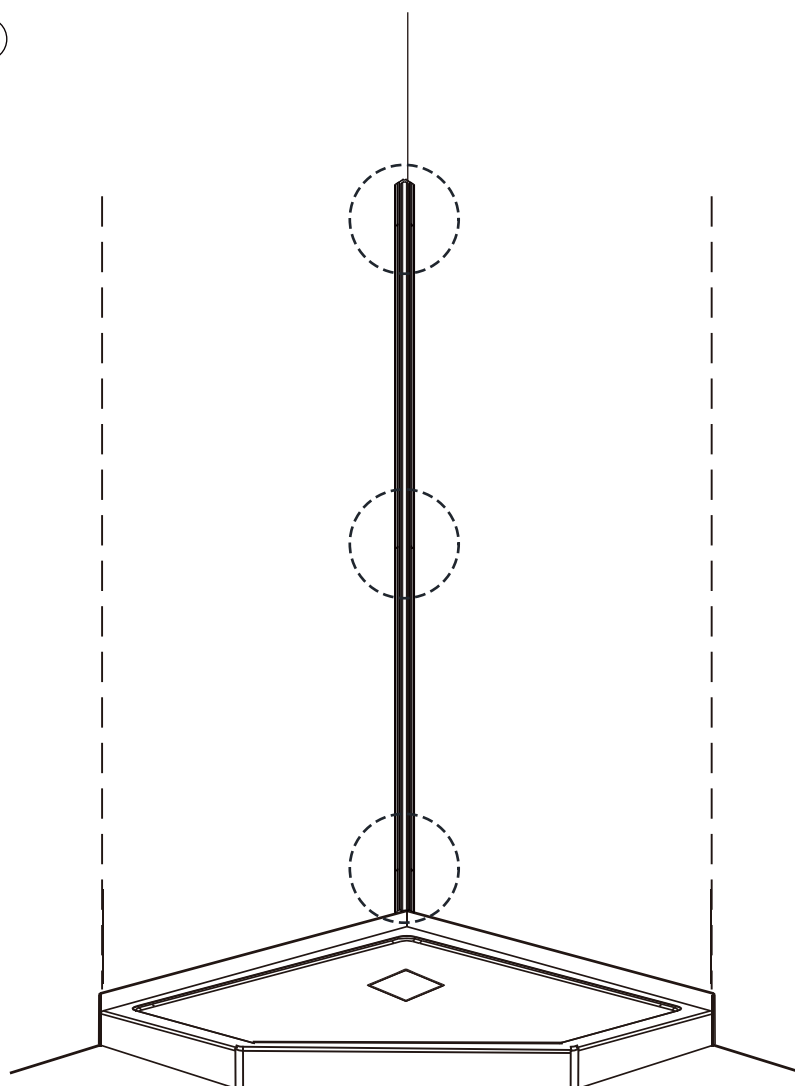
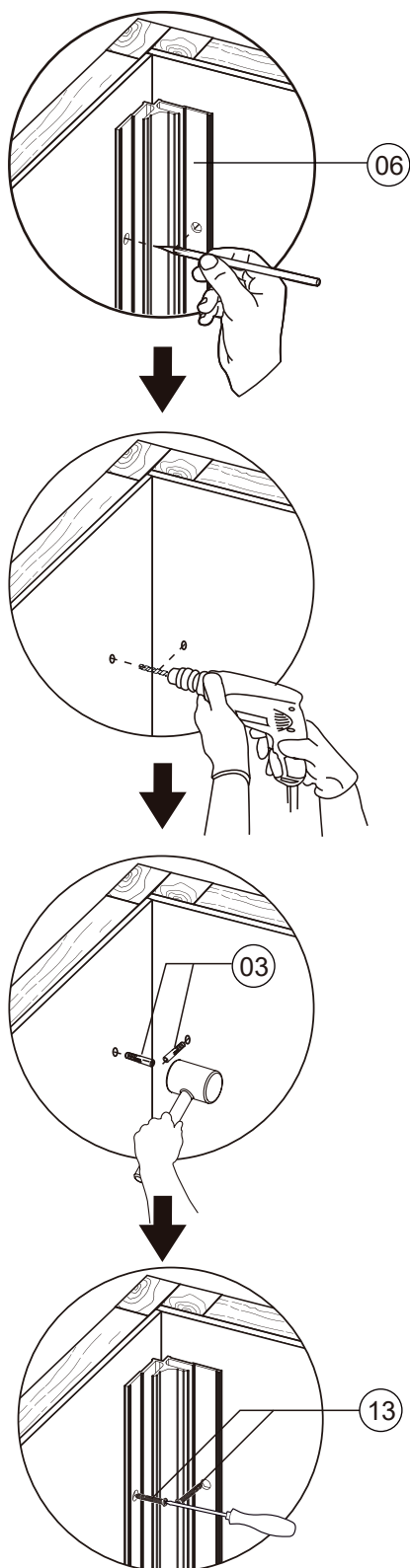



# Shower door Installation

Fig.9

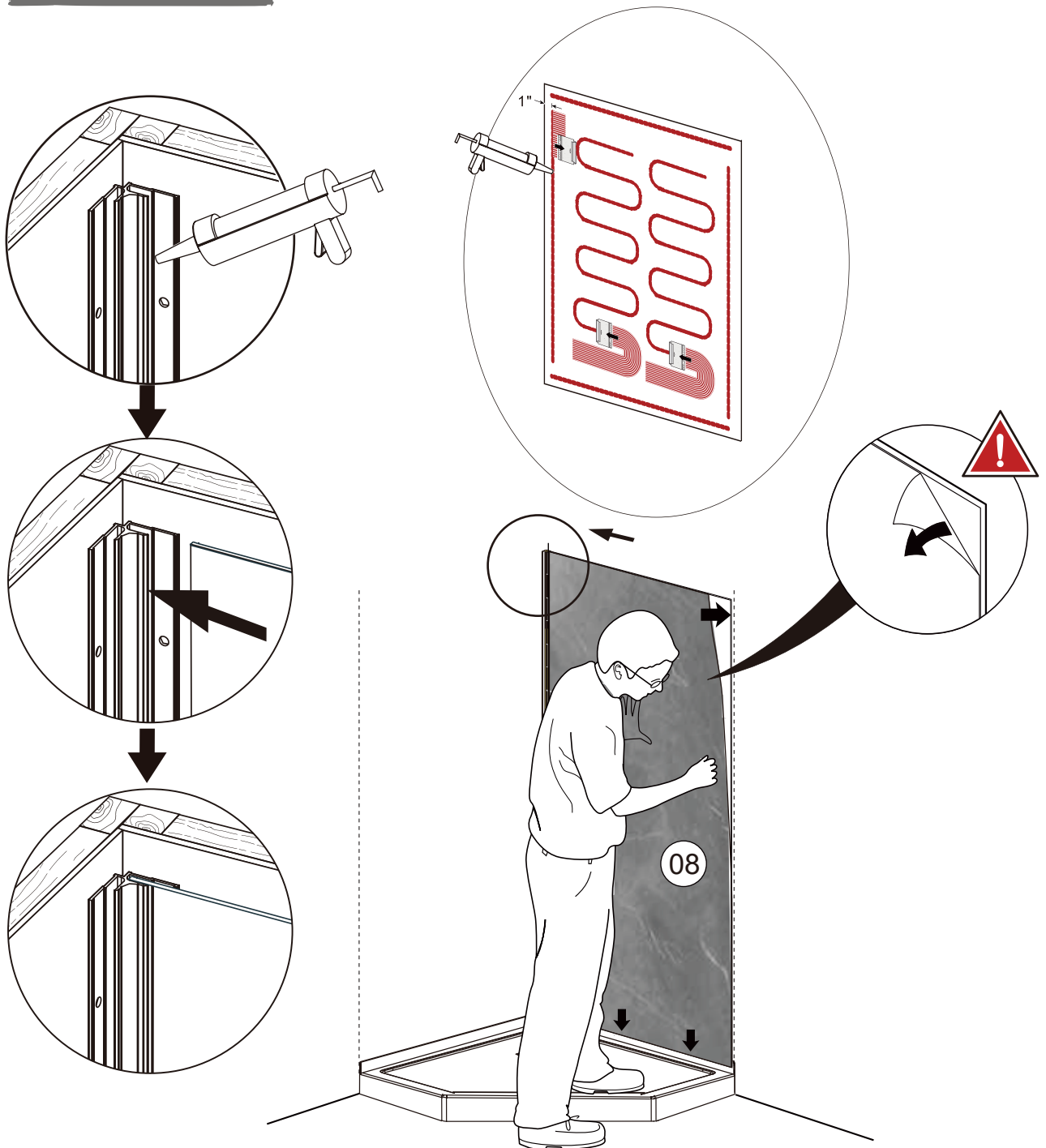

# Shower door Installation

Fig.10

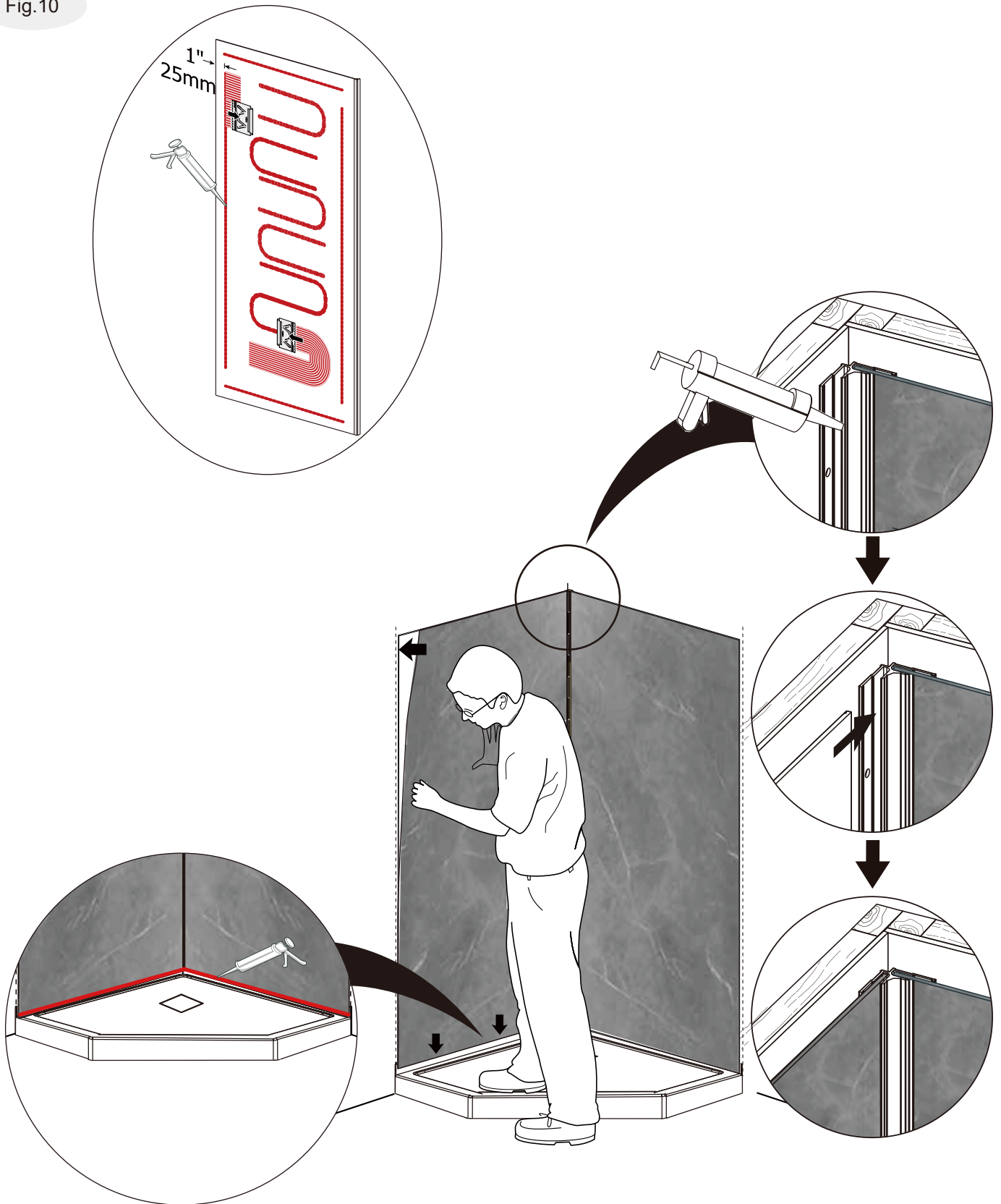

# Shower door Installation

Fig.11

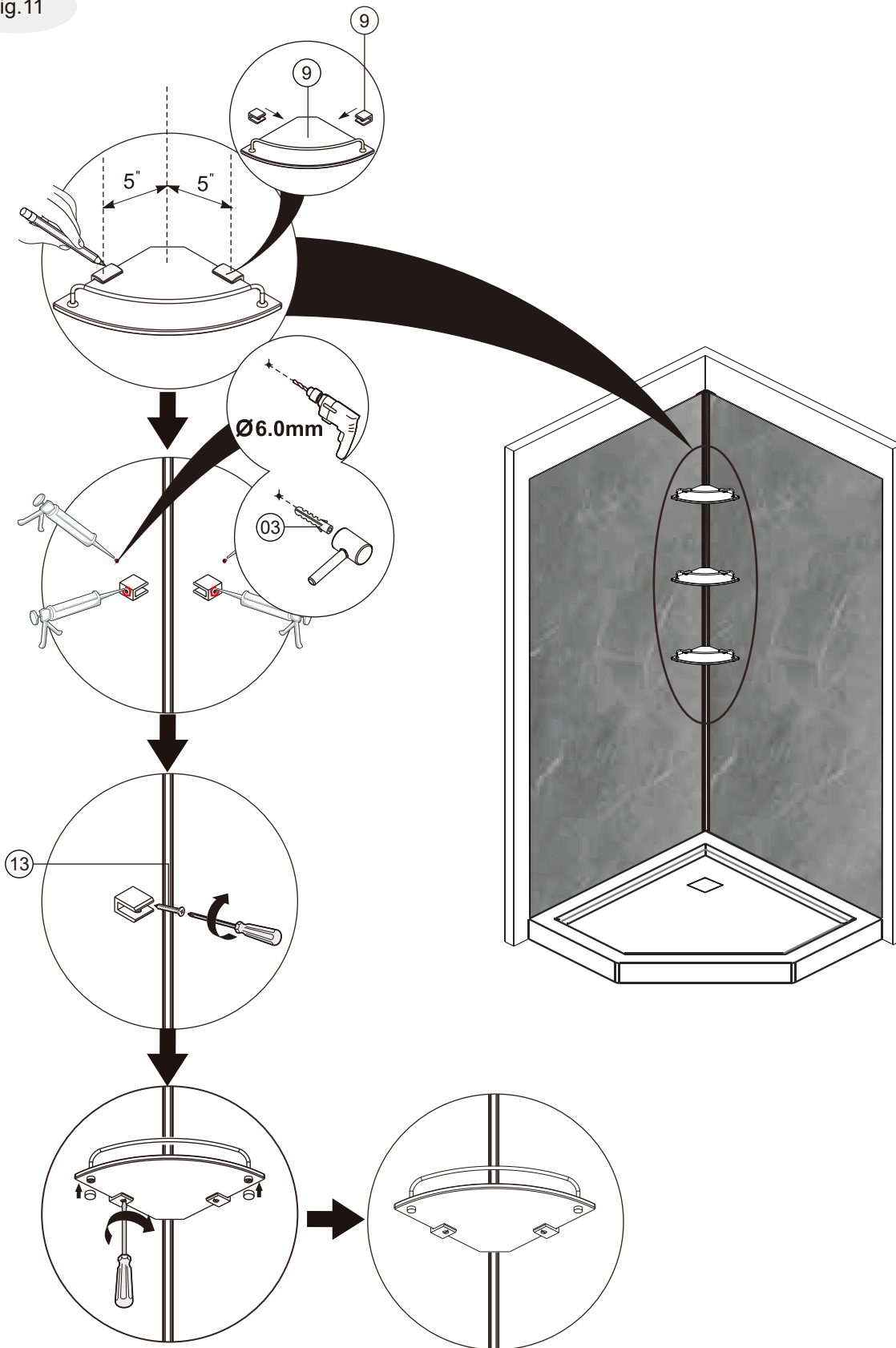

# Shower door Installation

Fig.12

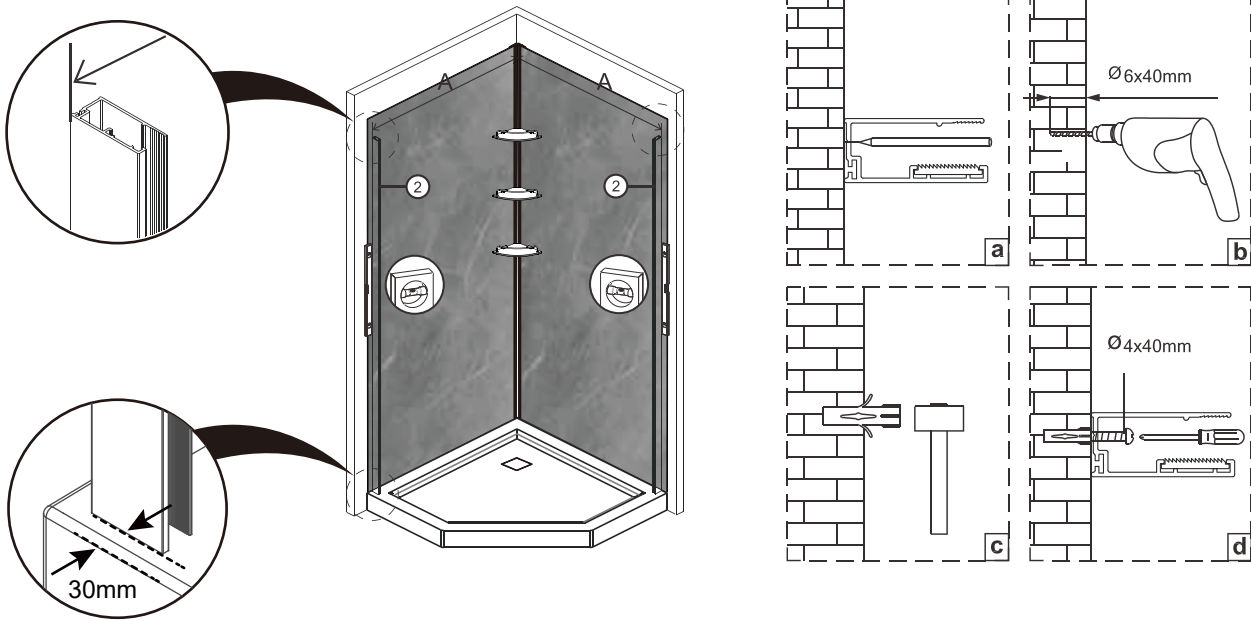
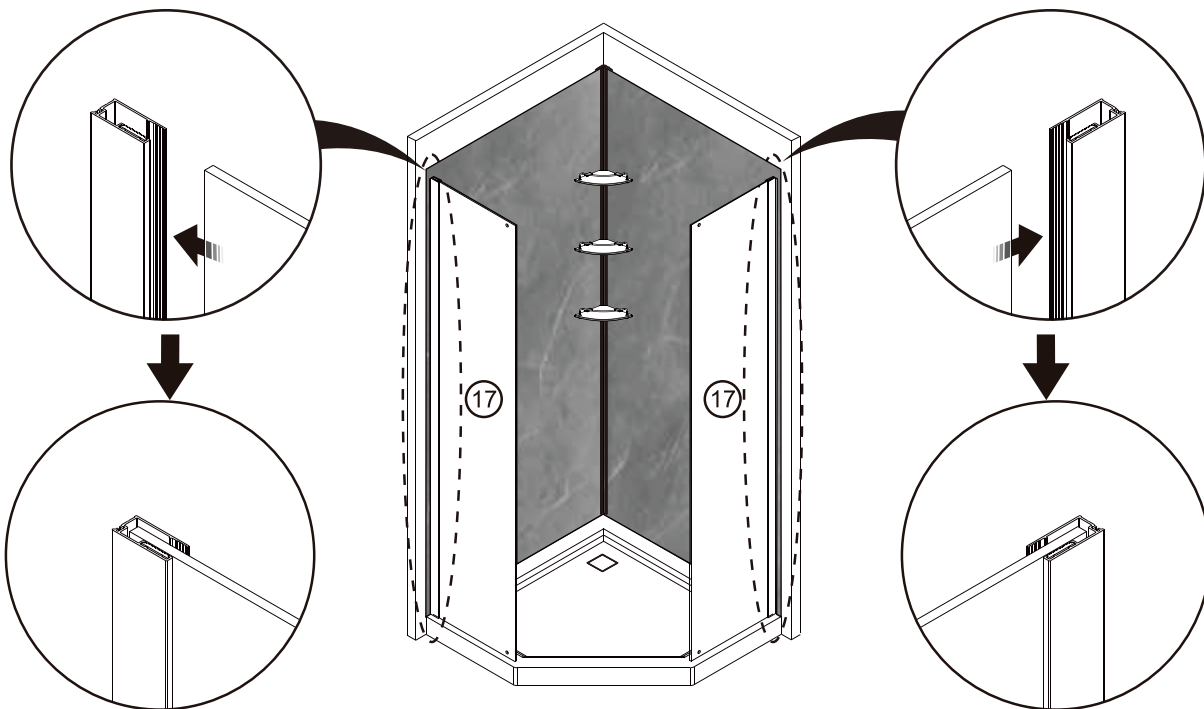
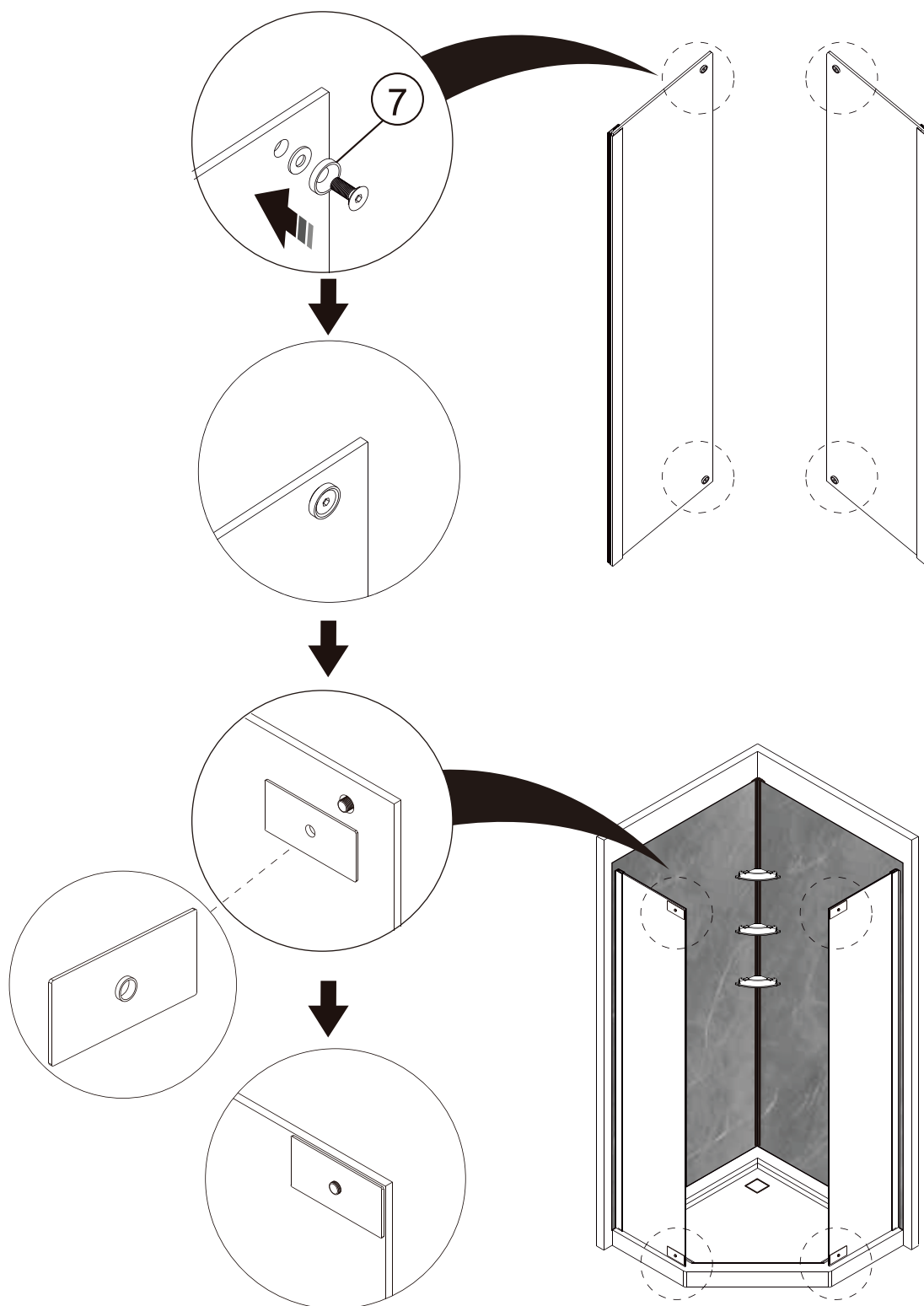

Fig.13



# Shower door Installation

Fig.14



# Shower door Installation

Fig.15

LH

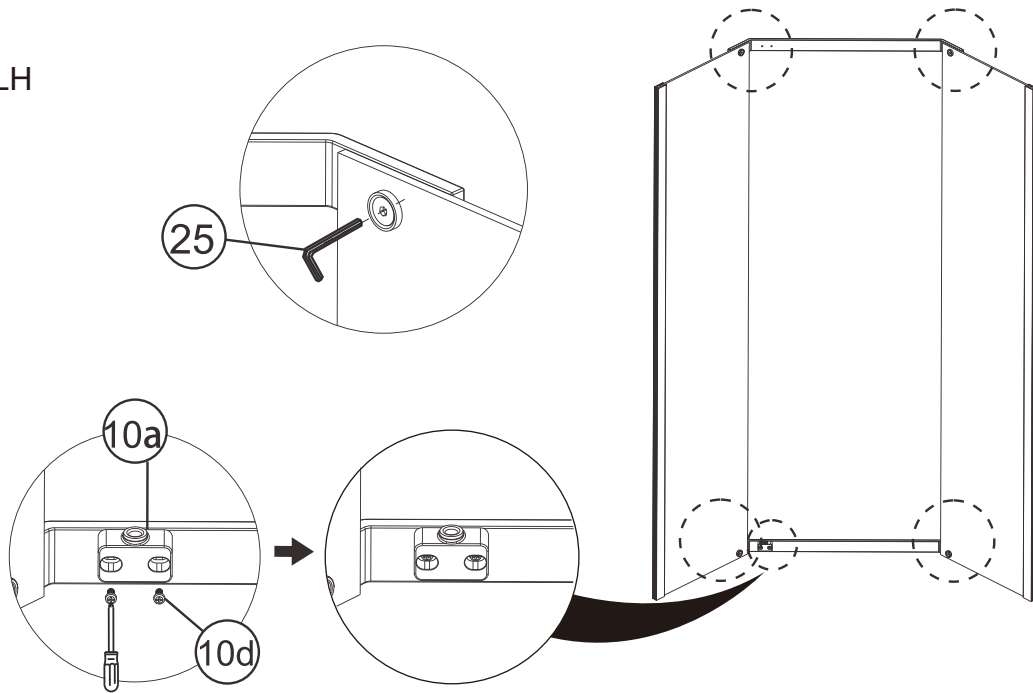

RH

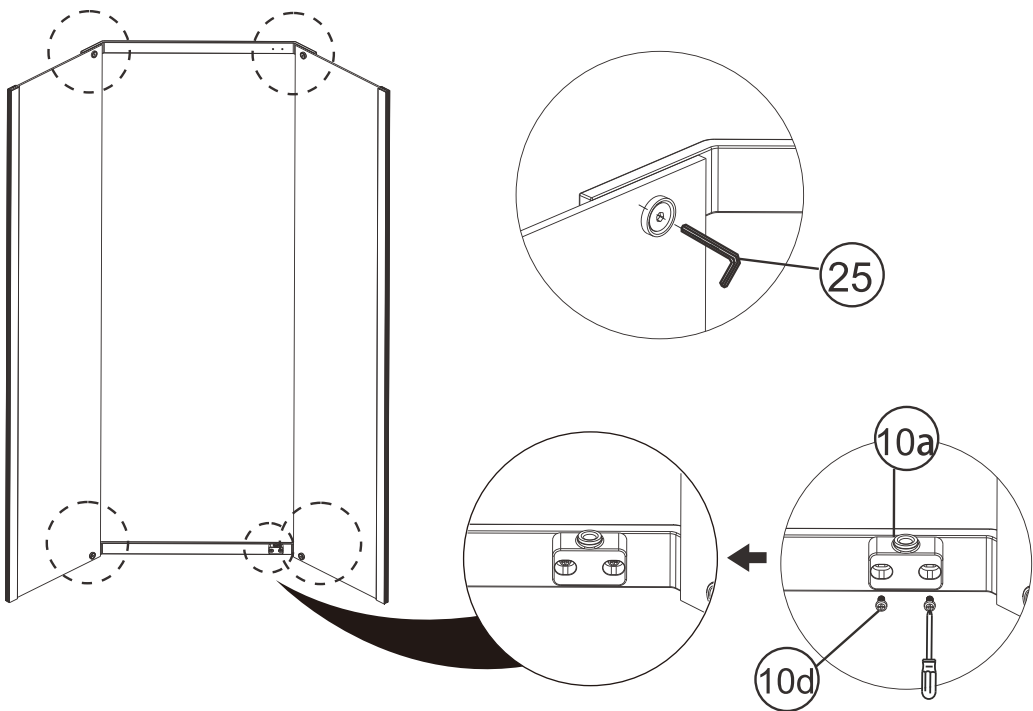

# Shower door Installation

Fig.16

LH

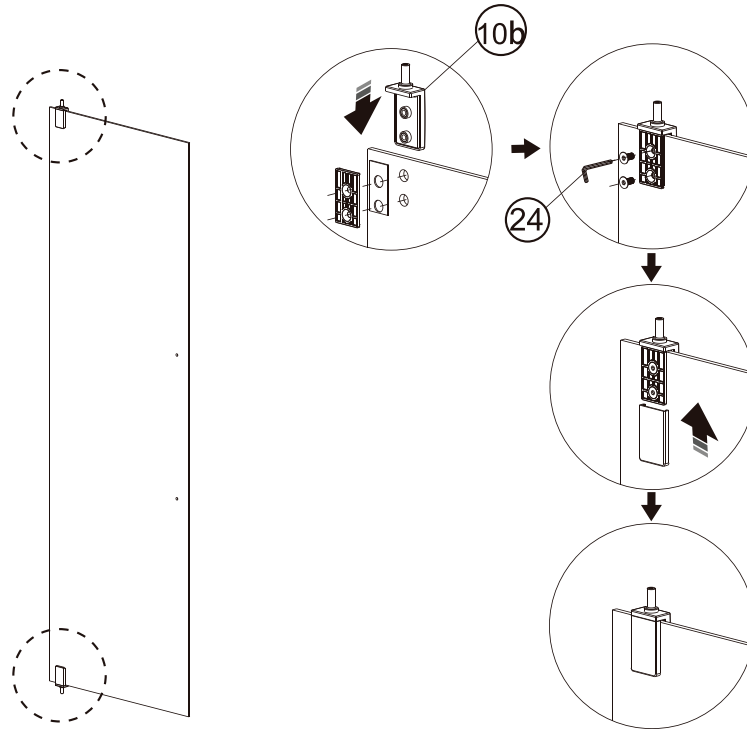

RH

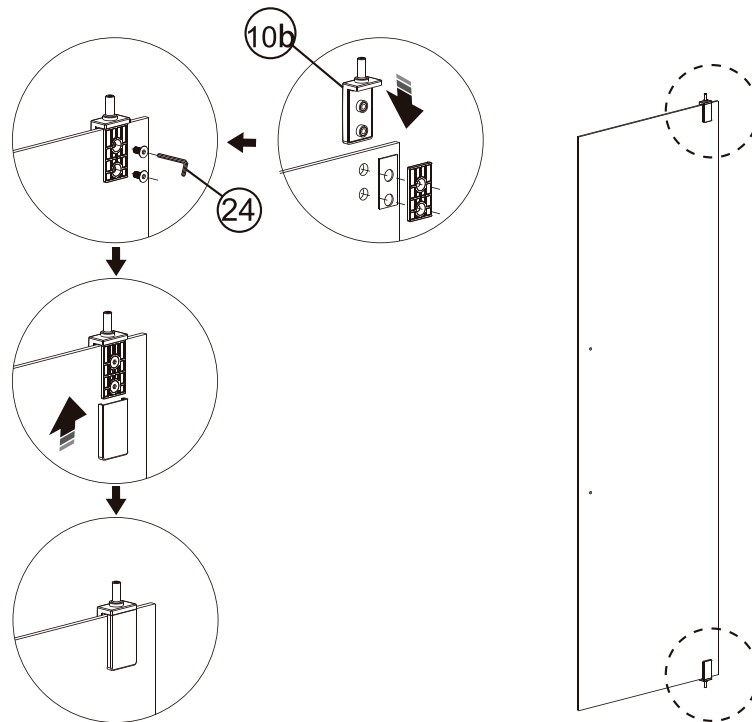

# Shower door Installation

Fig.17

LH

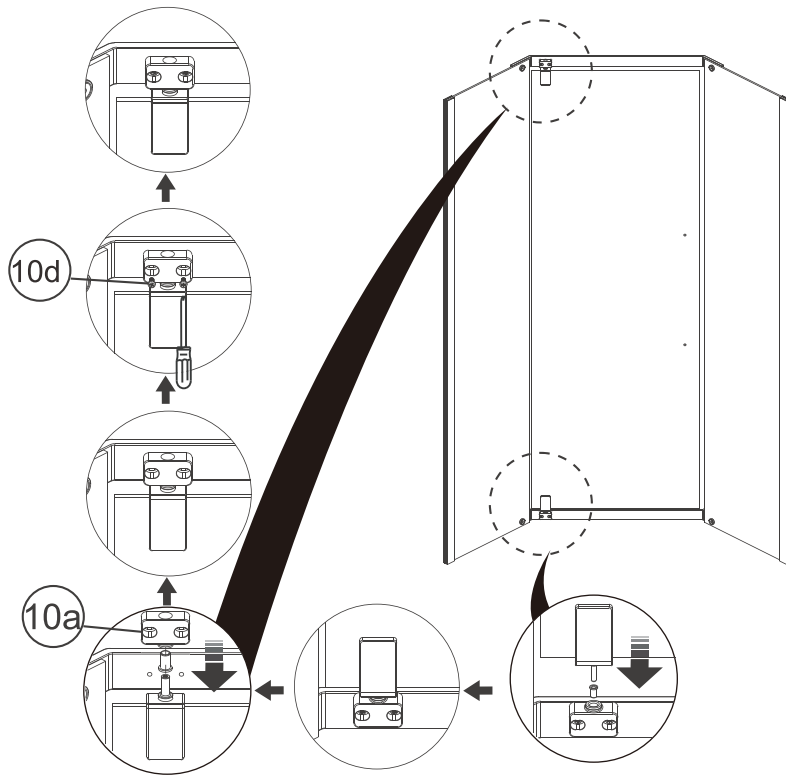

RH

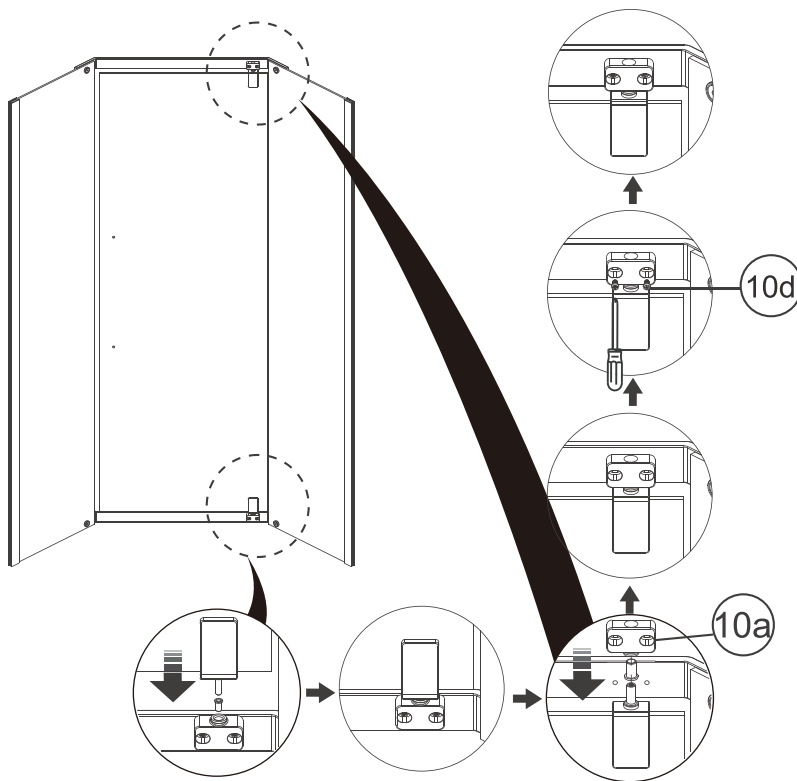



# Shower door Installation

Fig.18

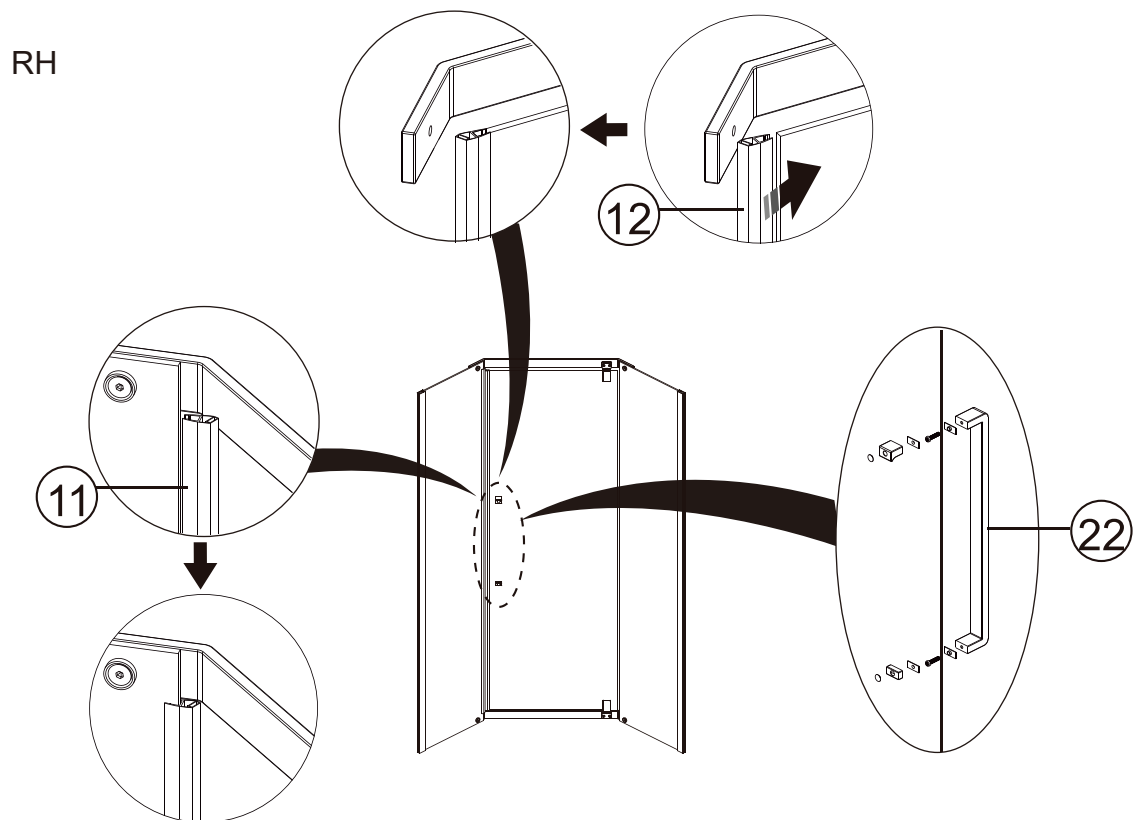
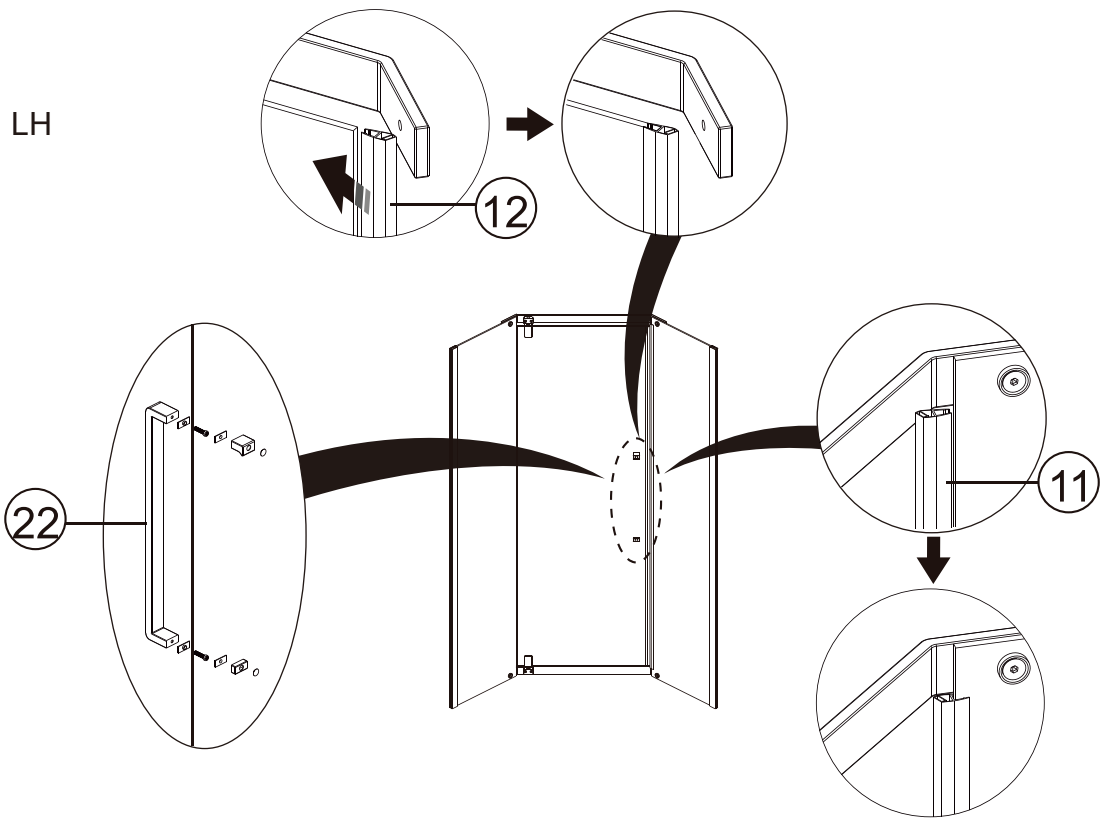

# Shower door Installation

Fig.19

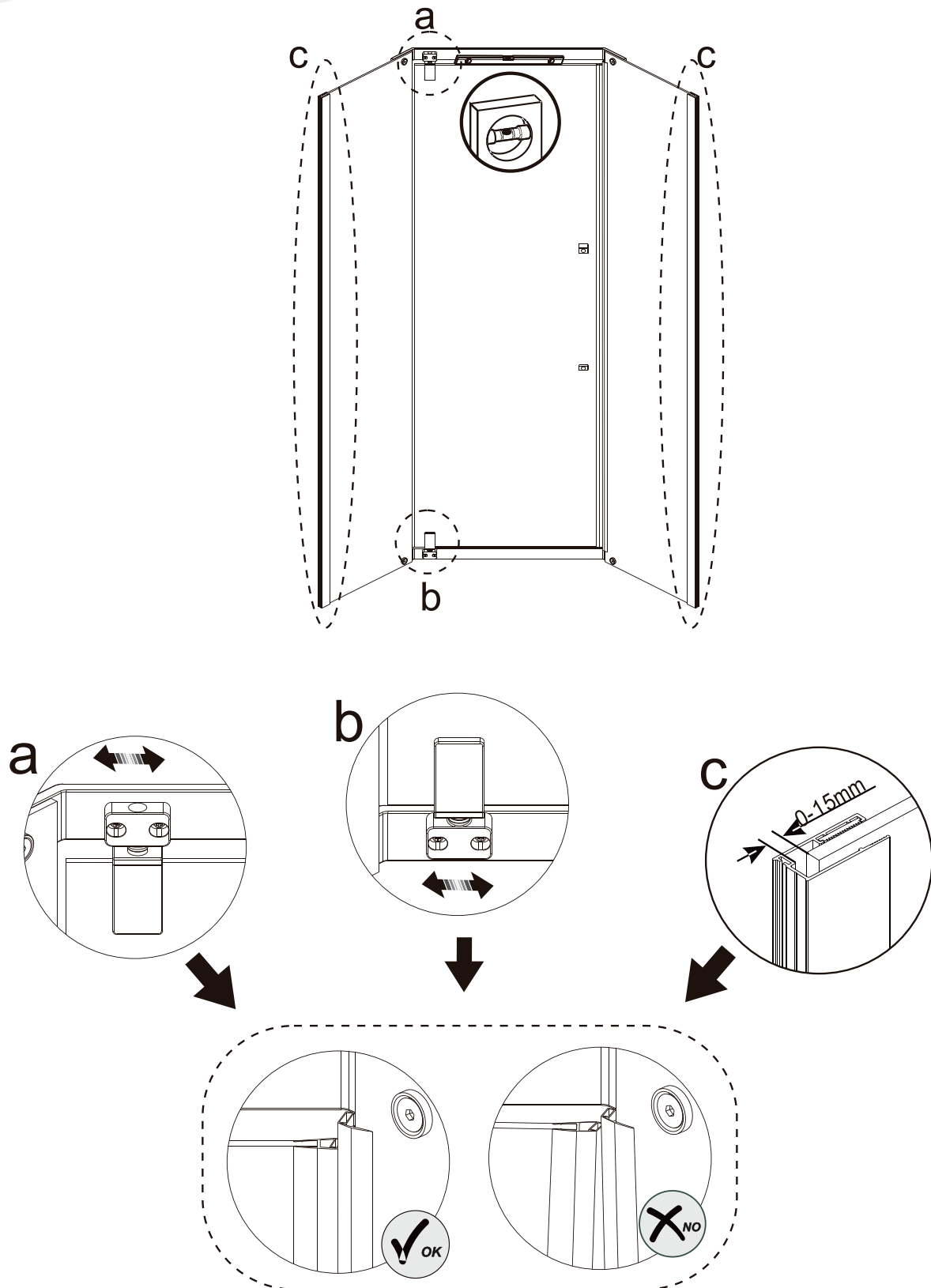

# Shower door Installation

Fig.20

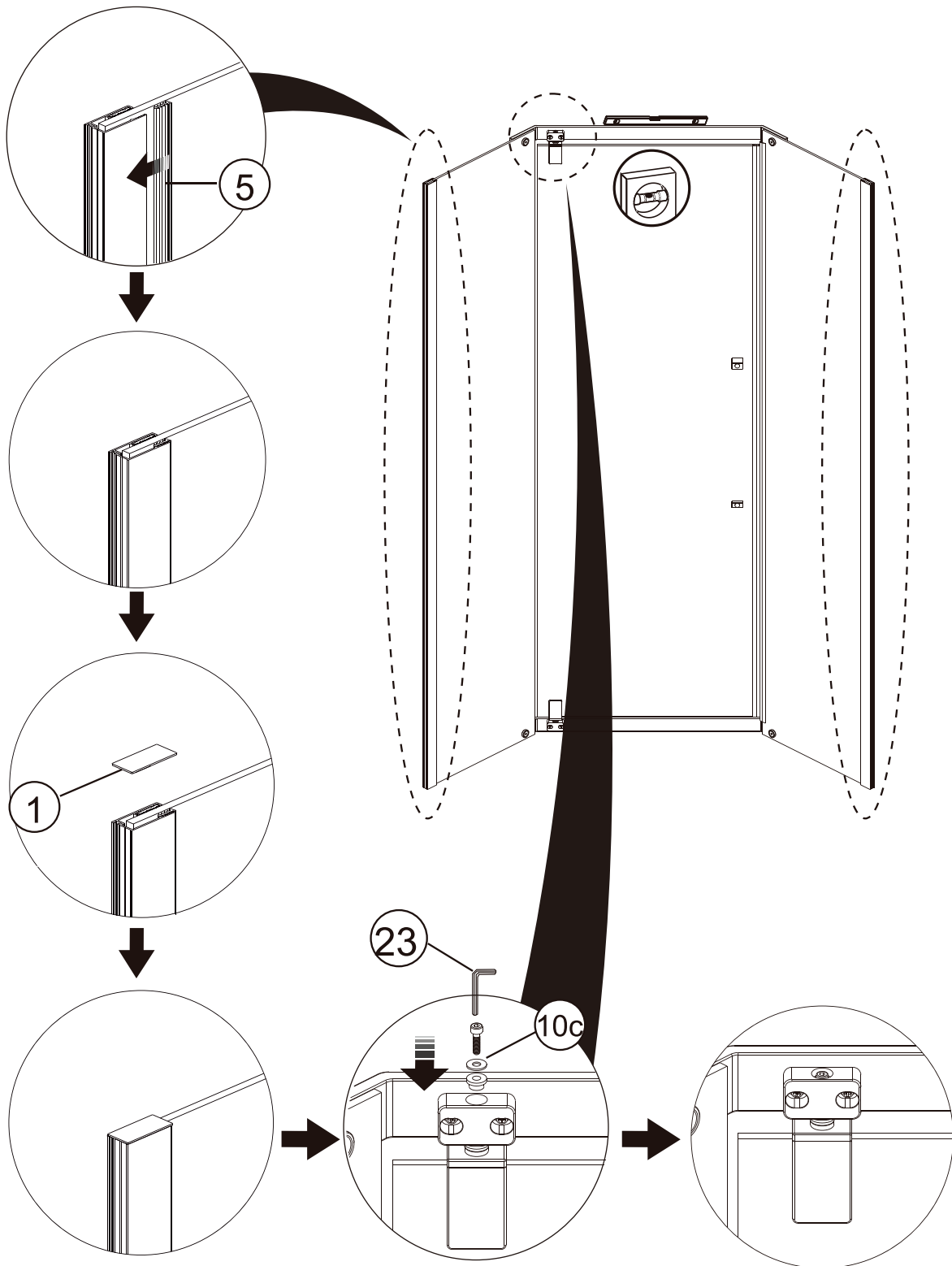

# Shower door Installation

Fig.21

LH

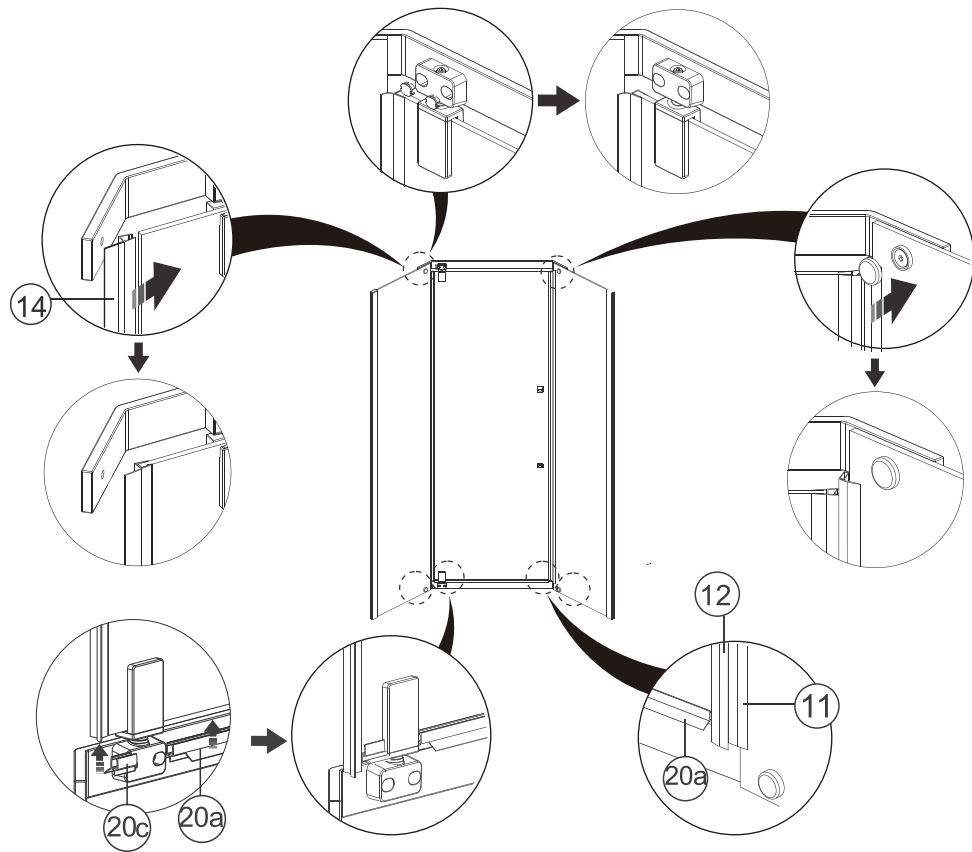

RH

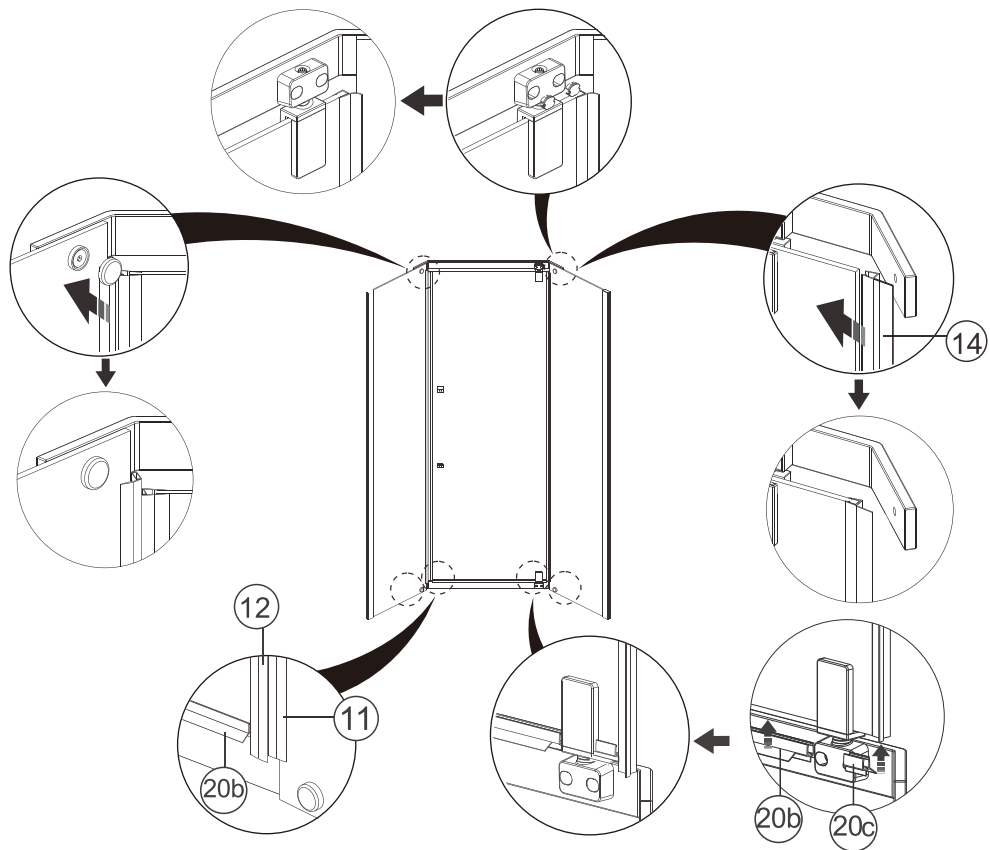

# Shower door Installation

Fig.22

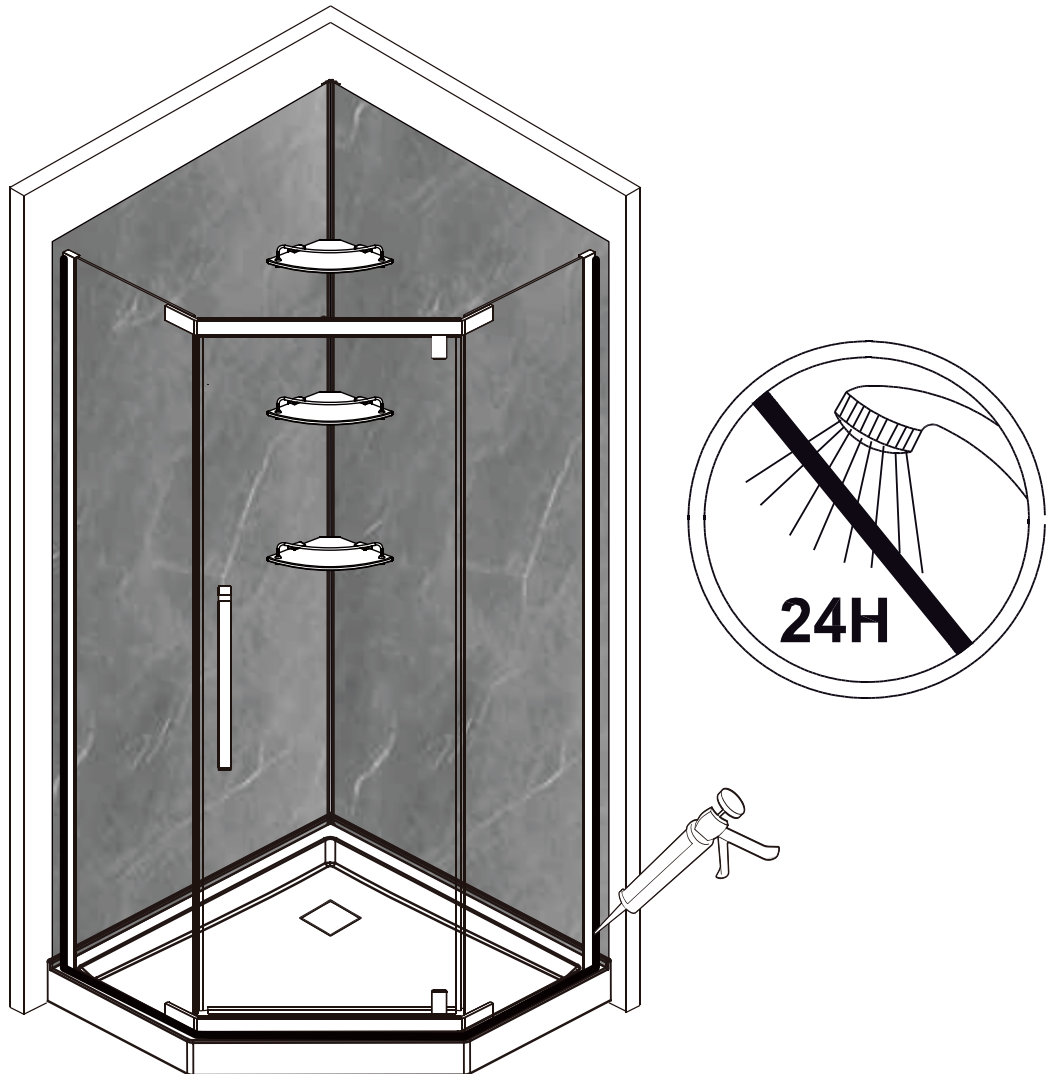



We certify that our products will meet your needs with their style, but also with their manufacturing quality. To make sure that they are reliable and safe, each product was carefully inspected, tested and approved during the quality control process that is in place.

### To whom does this warranty apply?

a **10-year limited warranty on shower bases and doors** from the date of purchase, exclusive to the first buyer as long as he/she resides in the same property. The warranty is intended for residential and/or domestic use.

### Care instructions

Clean the product with water and a mild detergent. Abrasive or corrosive cleaners, steel wool, acetone, dry cleaning products or ammonia compounds must never be used to clean the product. If a shower mat is used, it must be removed right after each use. We recommend the use of cleaning products that are made for acrylic specifically.

### What is covered by the warranty?

|                        | 1 Year*                                                        | 10 Years*                                            |
|------------------------|----------------------------------------------------------------|------------------------------------------------------|
| <b>Bases and walls</b> | Drain, drain cover, polypropylene and PVC                      | Acrylic and fiberglass against manufacturing defects |
| <b>Shower doors</b>    | Wheels, handles, diverter, screws, rails, towel bars and guide | Tempered glass                                       |

\*From the date of purchase.

Should there be any manufacturing defects that are not covered by the warranty, the product will need to be inspected prior to following through with the claim. Without that verification, the brand will assume no charge and/or responsibility.

### What are the exclusions?

The warranty doesn't apply if the product is damaged as a result of misuse, overuse or non-residential use, neglect, lack of maintenance, or the use of corrosive or abrasive products, regardless of the person who did those damages. The warranty does not cover shipping and labour costs. The warranty does not apply to the normal tear and wear of the goods.

The warranty doesn't cover the damages caused by the acts of God or breakage resulting from a shock or mishandling, regardless of the part played by the buyer or the installer. It also excludes the damages caused by an improper installation.

NADOLI doesn't cover damages caused by a water leak, even if they result directly or indirectly from a product defect, except where the applicable legislation does not allow any exclusion or limitation following indirect or consequential damages.

It is fair to say that if the product has a manufacturing defect, it will show as soon as it is installed or shortly after. However, a leak caused by an improper installation could happen a long time after. Therefore, it is strongly advised to have it done by a professional.

**All warranty claims must include the invoice copy.**

**Should a part or product component be defective or the finish damaged following a normal domestic and residential use, NADOLI commits to replacing the defective part(s) to the first buyer only. NADOLI could also, in its sole discretion, commit to offer a full replacement. No indemnity shall be claimed for loss of enjoyment of life, loss of income or losses caused by water.**