



**LED UFO High Bay**

Model: SZ-HB240W-AT3BM-5700K (ACP)

**Advantage:**

- UL&DLC certificate
- 2835 Chip, high CRI
- Input voltage 120-277VAC
- No UV or IR in the beam
- Easy to install and operate
- Energy saving, long lifespan
- Light is soft and uniform, safe to eyes
- Instant start, NO flickering, NO humming
- Green and eco-friendly without mercury.

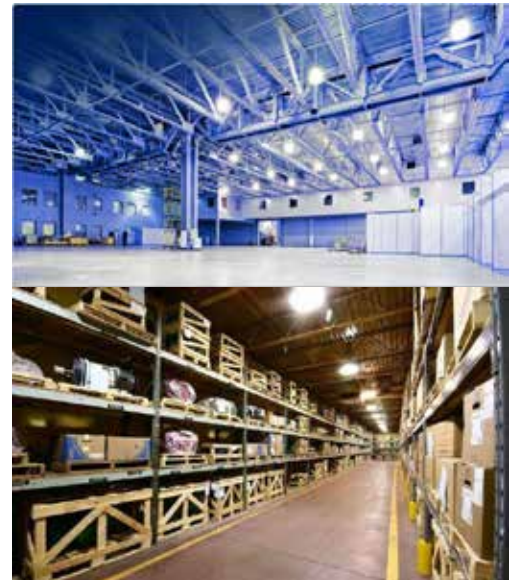

**Application:**

Warehouse, factory and workshops;  
 Highway toll station and gas station;  
 Exhibition hall;  
 Gymnasium and supermarkets, etc.

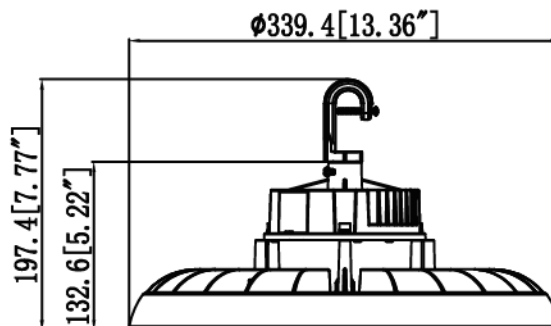

240W

## Product Specifications

Product Name	LED UFO High Bay
Light Type	SZ-HB240W-AT3BM-5700K (ACP)
Dimension	Φ339.4*197 mm

## Technical Characteristic

Color temperature	Adjustable CCT:4000K/5000K/5700K
CRI	>80
Lumen	33600LM
Lumen Efficacy	140LM/W
Input Power	Adjustable power: 150W/200W/240W
Viewing Angle	90 Degree
Input Voltage	120-277V 50/60Hz
Driver model	China Brand driver, (0-10Vdc Dimmer)
Motion sensor	Microwave sensor
PF	>0.9
Waterproof Rating	IP65

## Materials

LED Type	2835
LED QTY	720PCS
Housing	Aluminum(ADC12)
Housing color	Black
Cover	PC
Operating Temperature	-40°C TO 45°C
Operating Humidity	10%-90% RH
Storage Temperature	-40°C TO 80°C

## Others

Storage Humidity	10%-95%
Application	Outdoor
Safety Certification	UL&DLC
Warranty Time	5 Years

## Light Distribution Testing Parameters

DATA OF LAMP		PHOTOMETRIC DATA			
MODEL	HB240W	$I_{max}$ (cd)	18382	S/MH (C0/180)	1.19
NOMINAL POWER (W)	240	LOR (%)	100.0	S/MH (C90/270)	1.17
RATED VOLTAGE (V)	120	TOTAL FLUX (lm)	33771	$\eta$ UP, DN (C0-180)	1.2, 47.2
NOMINAL FLUX (lm)	33770.8	CIE CLASS	DIRECT	$\eta$ UP, DN (C180-360)	1.3, 50.2
LAMPS INSIDE	1	$\eta$ up (%)	2.5	CIBSE SHR NOM	1.00
TEST VOLTAGE (V)	120	$\eta$ down (%)	97.5	CIBSE SHR MAX	1.15

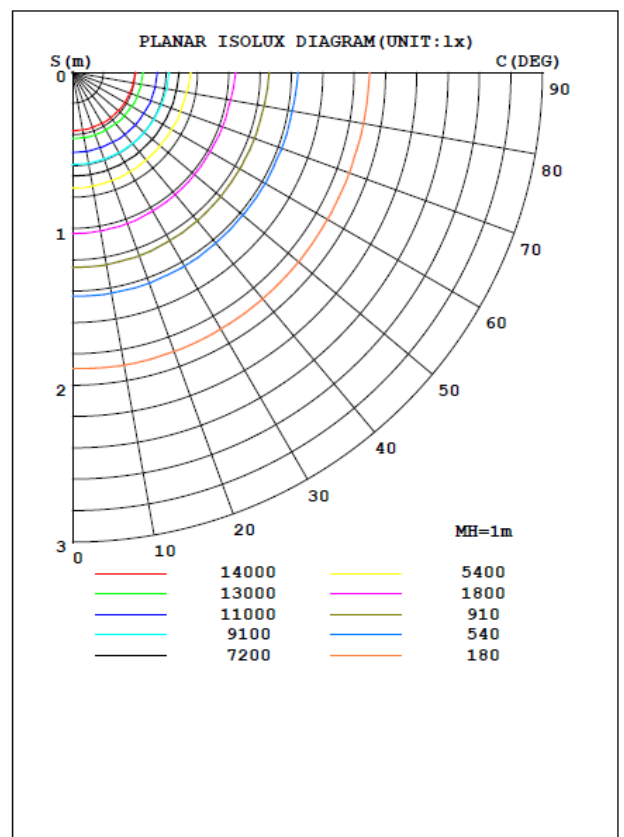
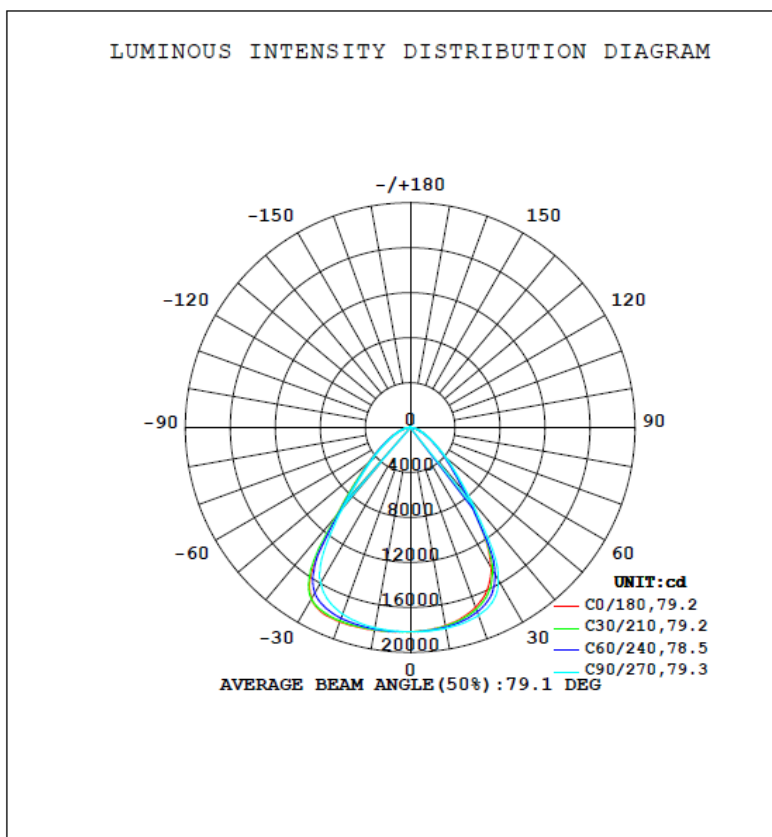

## Package

Model	Net Weight	Size	Qty/Carton	Weight/Carton
SZ-HB240W-AT3BM-5700K (ACP)	2.7 KG	397*397*17MM	1	3.75KG