



Night Glo LED 2-Light Set



This Kit Includes

- (2) LIGHTS WITH POWER CABLE
- (2) 1/2" BOLTS AND NUTS
- (2) STAINLESS STEEL ARMS
- TIMER CONTROL UNIT

Tools Needed

- 7/16" AND 1/2" WRENCHES AND PLIERS

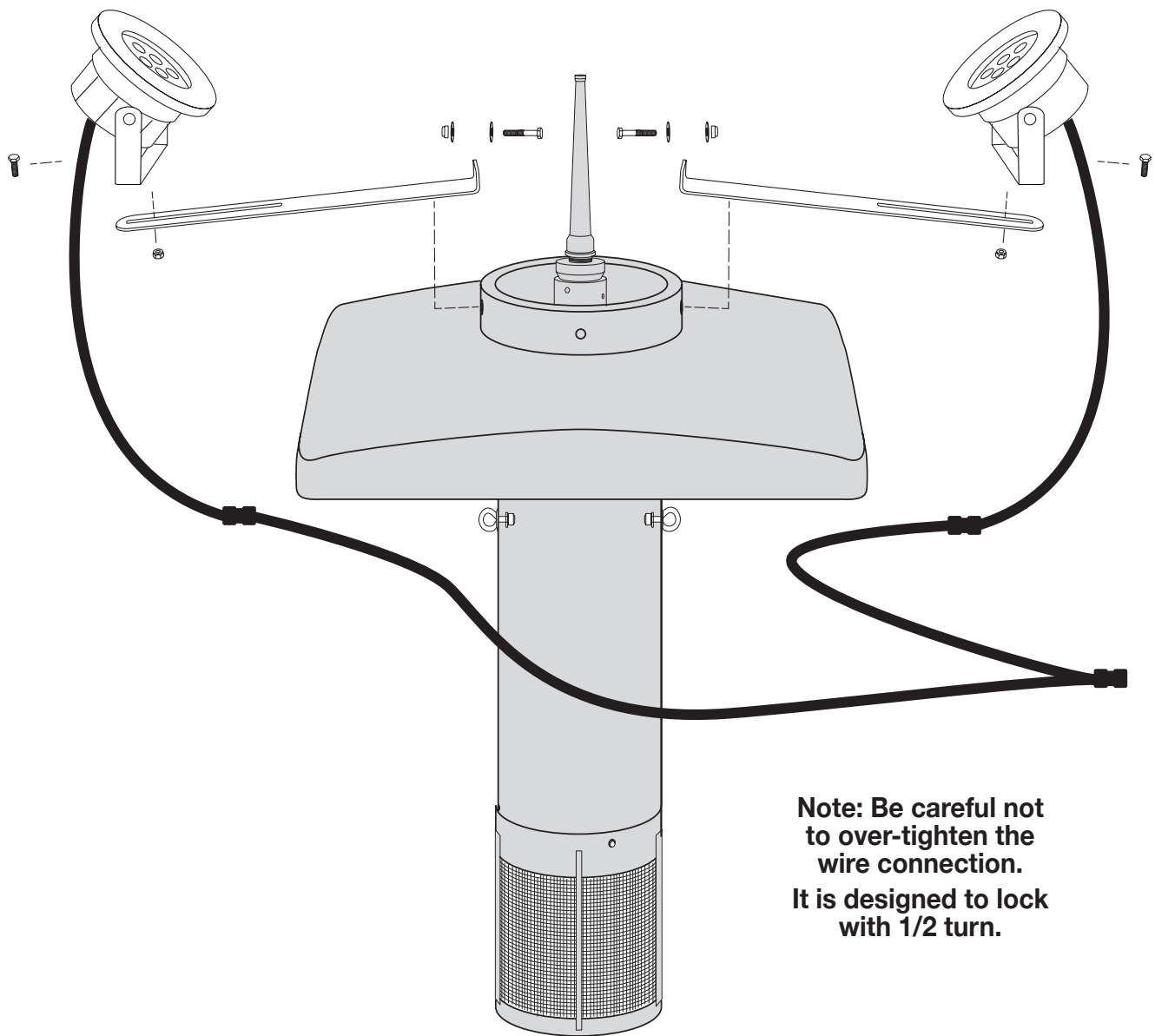

Note: Be careful not to over-tighten the wire connection. It is designed to lock with 1/2 turn.

Assembly Instructions

1. Attach each arm assembly to the water feature. Be sure to orient the arms with "L" facing upward. Remove one of the 2" bolts attaching the float to your Scott water feature and align the holes with the stainless steel arm. Reinsert the bolt with washer, outward through the housing, float and stainless steel arm. Secure with washer and nut. Repeat for second arm assembly.
2. Continue by attaching each light to the slotted end of the stainless steel arms. Feed 1/2" x 1/4" bolt downward through each light bracket and steel arm then secure with 1/4" nut. The lights can be positioned along the arm by loosening the lock nut, sliding the light to the desired position, then re-tightening the nut.
3. Connect the lights to the Timer Control Unit by aligning pins and screwing the connector together 1/2 turn only. **Do not force the connection tight or you may damage the O-ring or wiring.**



Manual Function Operation Instructions

1. Unlock the programmer by pressing the “C/R” button four times. This will remove the “a” symbol from the lower left corner of the screen and allow input on the device. If no inputs are pressed in 15 seconds, the device will lock itself again. To lock it manually, press the “C/R” button again.
2. Press the “Manual” button to cycle through available settings. Settings will appear in this order:
On, Auto, Off, Auto.
Selecting On will provide power to the lights.
Selecting Auto right after the On setting will provide power to the lights until the next programmed Off function.
Selecting Off will stop providing power to the lights.
Selecting Auto right after the Off setting will turn off power to the lights until the next programmed On function.

Programming Instructions for One On and Off Setting for All Seven Days

1. Unlock the programmer by pressing the “C/R” button four times. This will remove the “a” symbol from the lower left corner of the screen and allow input on the device. If no inputs are pressed in 15 seconds, the device will lock itself again. To lock it manually, press the “C/R” button again.
2. Press the “C” button to reset the device. It is inset to prevent accidental presses and will require a pen or small tool to press.
3. Set the time by pressing the clock icon and using the D+, H+, and M+ to adjust the time.
4. Press the “P” key to set a time for the display to turn on. Using the H+ and M+ buttons to adjust to the desired time. Time is displayed in military time only.
5. Press the D+ button until the display shows all seven days across the top then press the “P” button.
6. Use the H+ and M+ buttons to set the time for the display to turn off.
7. When finished, press the clock icon to lock in your settings.

Programming Instructions for Multiple On and Off Settings

1. Unlock the programmer by pressing the “C/R” button four times. This will remove the “a” symbol from the lower left corner of the screen and allow input on the device. If no inputs are pressed in 15 seconds, the device will lock itself again. To lock it manually, press the “C/R” button again.
2. Press the “C” button to reset the device. It is inset to prevent accidental presses and will require a pen or small tool to press.
3. Set the time by pressing the clock icon and using the D+, H+, and M+ to set the day and adjust the time. Time is displayed in military time only.
4. Press the “P” key to set a time for the display to turn on. Using the H+ and M+ buttons to adjust to the desired time.
5. Press the D+ button until the display shows all the desired combination of days for this setting across the top then press the “P” button.
6. Use the H+ and M+ buttons to set the time for the display to turn off.
7. Repeat steps 4 through 6 for each desired setting, up to 16 settings can be programmed. Times should be set in order as settings cannot overlap.
8. When finished, press the clock icon to lock in your settings.

The Scott Aerator Awesome Warranty

All standard Scott Aerator products are unconditionally warranted for five years against motor defects in materials or workmanship, under normal operating conditions. All other product components are warranted for one year from date of purchase. Scott Aerator will repair or replace failed parts under warranty when the defective unit is returned to the factory, shipping prepaid, and factory inspection establishes that the part was defective. The unit must be returned to the factory prior to shipment of replacement parts. All parts replaced under this warranty will be returned with shipping prepaid. Scott Aerator will not be liable for consequential damage nor for any costs associated with removal or attempts to repair components in the field.



13245 Barry Street, Holland, MI 49424

scottaerator.com

information@scottaerator.com

800-WATER-45 (800-928-3745)

(616) 392-8882





Night Glo LED 4-Light Set



This Kit Includes

- (4) LIGHTS WITH POWER CABLE
- (4) 1/2" BOLTS AND NUTS
- (4) STAINLESS STEEL ARMS
- TIMER CONTROL UNIT

Tools Needed

7/16" AND 1/2" WRENCHES AND PLIERS

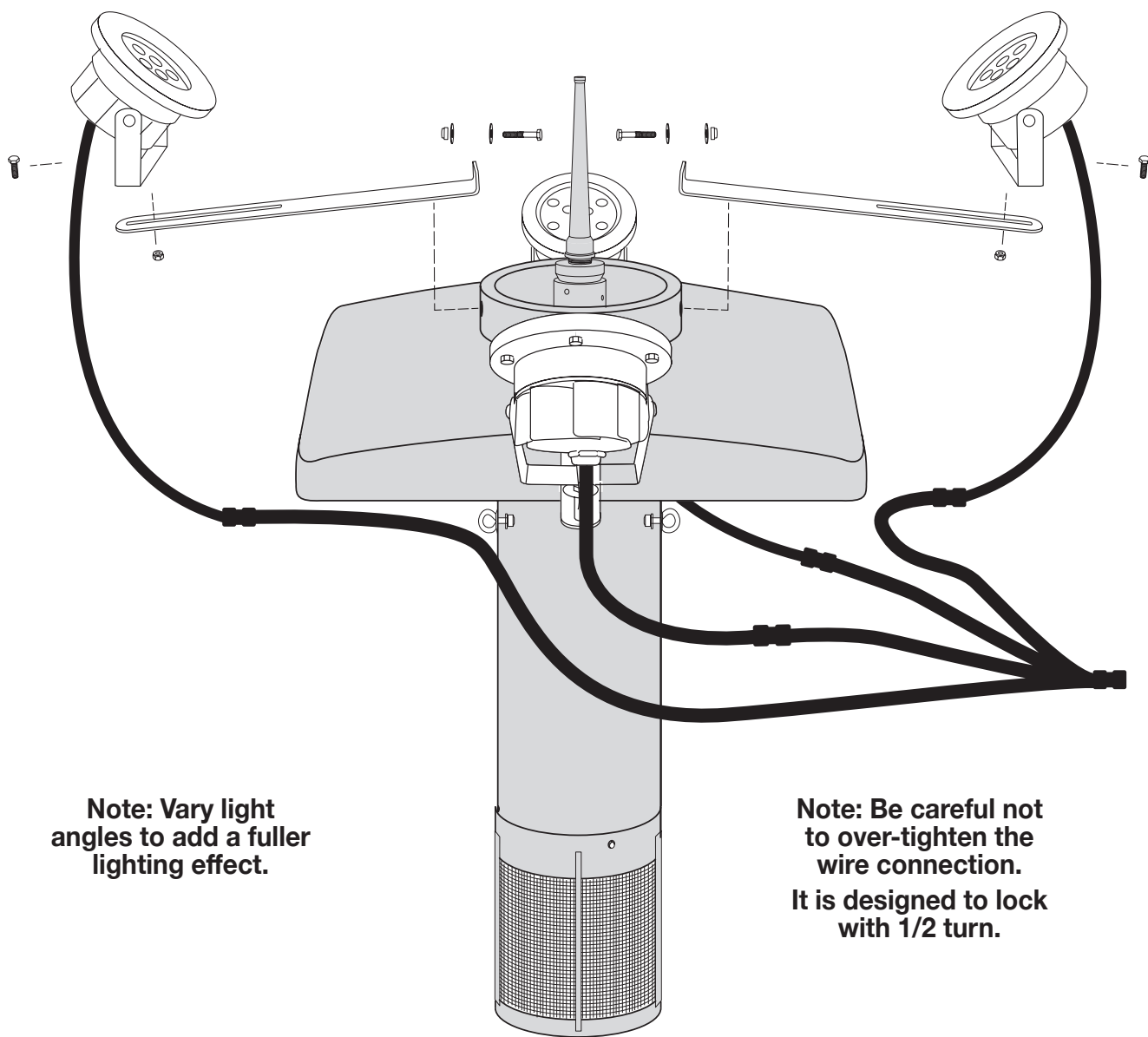

Note: Vary light angles to add a fuller lighting effect.

Note: Be careful not to over-tighten the wire connection. It is designed to lock with 1/2 turn.

Assembly Instructions

1. Attach each arm assembly to the water feature. Be sure to orient the arms with "L" facing upward. Remove one of the 2" bolts attaching the float to your Scott water feature and align the holes with the stainless steel arm. Reinsert the bolt with washer, outward through the housing, float and stainless steel arm. Secure with washer and nut. Repeat for each arm assembly.
2. Continue by attaching each light to the slotted end of the stainless steel arms. Feed 1/2" x 1/4" bolt downward through each light bracket and steel arm then secure with 1/4" nut. The lights can be positioned along the arm by loosening the lock nut, sliding the light to the desired position, then re-tightening the nut.
3. Connect the lights to the Timer Control Unit by aligning pins and screwing the connector together 1/2 turn only. **Do not force the connection tight or you may damage the O-ring or wiring.**



Manual Function Operation Instructions

1. Unlock the programmer by pressing the “C/R” button four times. This will remove the “a” symbol from the lower left corner of the screen and allow input on the device. If no inputs are pressed in 15 seconds, the device will lock itself again. To lock it manually, press the “C/R” button again.
2. Press the “Manual” button to cycle through available settings. Settings will appear in this order:
On, Auto, Off, Auto.
Selecting On will provide power to the lights.
Selecting Auto right after the On setting will provide power to the lights until the next programmed Off function.
Selecting Off will stop providing power to the lights.
Selecting Auto right after the Off setting will turn off power to the lights until the next programmed On function.

Programming Instructions for One On and Off Setting for All Seven Days

1. Unlock the programmer by pressing the “C/R” button four times. This will remove the “a” symbol from the lower left corner of the screen and allow input on the device. If no inputs are pressed in 15 seconds, the device will lock itself again. To lock it manually, press the “C/R” button again.
2. Press the “C” button to reset the device. It is inset to prevent accidental presses and will require a pen or small tool to press.
3. Set the time by pressing the clock icon and using the D+, H+, and M+ to adjust the time.
4. Press the “P” key to set a time for the display to turn on. Using the H+ and M+ buttons to adjust to the desired time. Time is displayed in military time only.
5. Press the D+ button until the display shows all seven days across the top then press the “P” button.
6. Use the H+ and M+ buttons to set the time for the display to turn off.
7. When finished, press the clock icon to lock in your settings.

Programming Instructions for Multiple On and Off Settings

1. Unlock the programmer by pressing the “C/R” button four times. This will remove the “a” symbol from the lower left corner of the screen and allow input on the device. If no inputs are pressed in 15 seconds, the device will lock itself again. To lock it manually, press the “C/R” button again.
2. Press the “C” button to reset the device. It is inset to prevent accidental presses and will require a pen or small tool to press.
3. Set the time by pressing the clock icon and using the D+, H+, and M+ to set the day and adjust the time. Time is displayed in military time only.
4. Press the “P” key to set a time for the display to turn on. Using the H+ and M+ buttons to adjust to the desired time.
5. Press the D+ button until the display shows all the desired combination of days for this setting across the top then press the “P” button.
6. Use the H+ and M+ buttons to set the time for the display to turn off.
7. Repeat steps 4 through 6 for each desired setting, up to 16 settings can be programmed. Times should be set in order as settings cannot overlap.
8. When finished, press the clock icon to lock in your settings.

The Scott Aerator Awesome Warranty

All standard Scott Aerator products are unconditionally warranted for five years against motor defects in materials or workmanship, under normal operating conditions. All other product components are warranted for one year from date of purchase. Scott Aerator will repair or replace failed parts under warranty when the defective unit is returned to the factory, shipping prepaid, and factory inspection establishes that the part was defective. The unit must be returned to the factory prior to shipment of replacement parts. All parts replaced under this warranty will be returned with shipping prepaid. Scott Aerator will not be liable for consequential damage nor for any costs associated with removal or attempts to repair components in the field.



13245 Barry Street, Holland, MI 49424

scottaerator.com

information@scottaerator.com

800-WATER-45 (800-928-3745)

(616) 392-8882

