

# WaterGlow LIGHTING

## Instructions for Installation on 3-Piece Sectional Float

### Kit 840306

**NOTE** This kit includes supplementary hardware required to mount LED6C11, RGB6C5, or LED6S19 light kits to Kasco units with three-piece sectional floats. The LEDC11 is pictured for reference; use the same method to secure the hardware to the mounting brackets on RGBC5 and LEDS19 lights.

#### PARTS INCLUDED

ID	Description	Qty	Part No.
A	1/4"-20 x 5" hex head screw	6	345046
B	4" spacer	6	345047
C	Lower float bracket	6	840158
D	3/8" x 1.25" OD fender washer	3	840325
E	1/4" flat washer	6	258476
F	1/4" split lock washer	6	840537
G	1/4"-20 nut	6	840536

#### TOOLS REQUIRED



7/16" wrench  
9/16" wrench

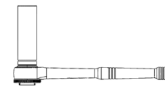

7/16" socket and driver  
9/16" socket and driver

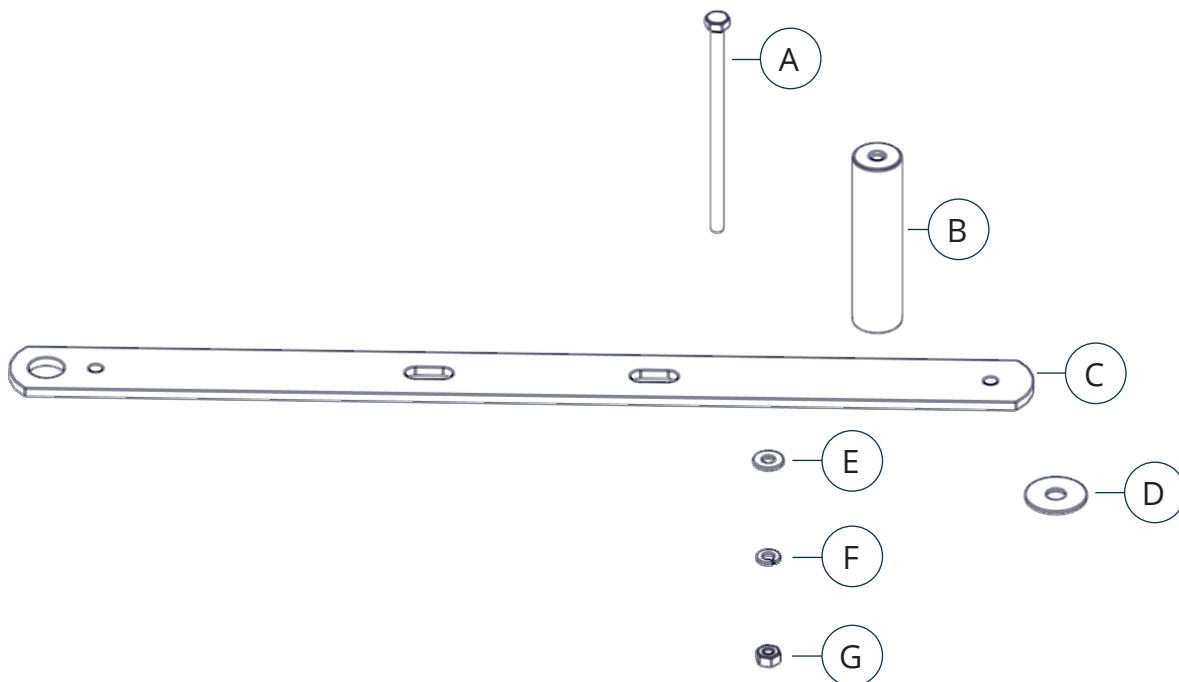

## INSTALLATION INSTRUCTIONS

1. Turn the unit upside down. Loosen and remove the 3/8" nut on the 9" bolts that are closest to the motor unit. 9/16" socket and wrench required. Place (2) lower float brackets (C) and one 3/8" fender washer (D) on the 9" bolt on the bottom screen clips and replace the 3/8" nut, threading on lightly.

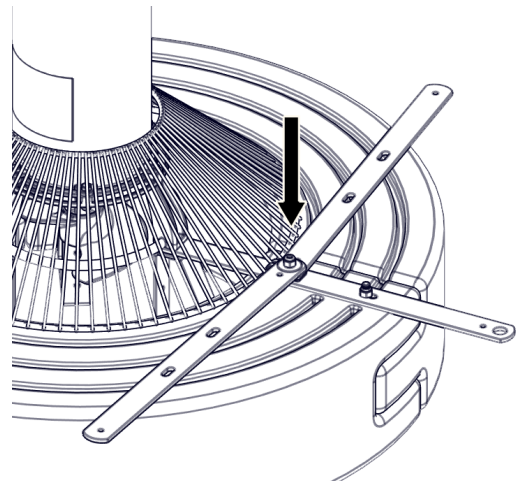
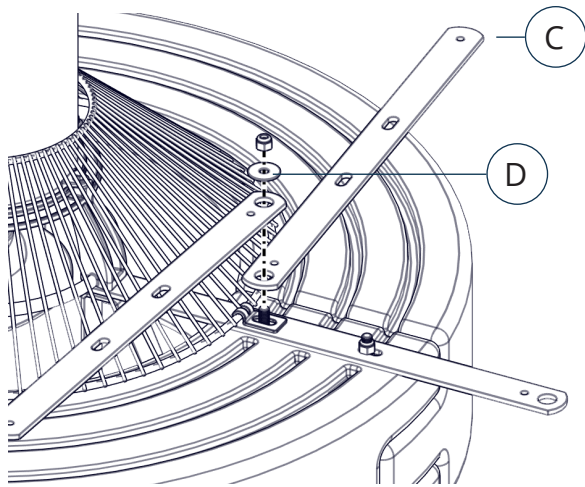

2. Repeat for the other two sides of the unit, overlapping the free ends of the brackets and aligning the holes. Tighten the 3/8" nuts until secure.

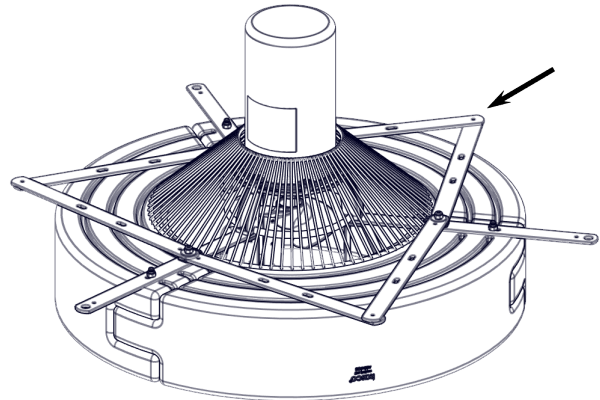

3. Flip unit back over to upright position. Secure the light fixtures to the lower float bracket using the 1/4"-20 x 5" hex screw (A), 4" spacer (B), 1/4" flat washer (E), 1/4" split lock washer (F), and 1/4"-20 nut (G). 7/16" socket and wrench required. Repeat for all six fixtures and continue with standard installation instructions included with light kit.

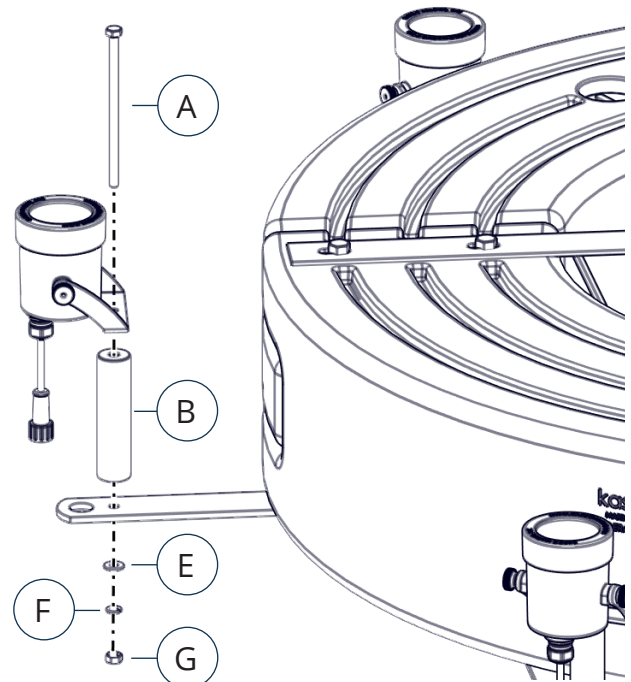

**Kasco**<sup>®</sup>