

RAEV

BULLET PRO / GT

User Manual of Electric Bicycle



Note:

PRO version means
a single battery and
GT version means
double batteries

Contents

1.Basic Information	02	6.Precautions about Use	11
1.1 Unpacking Information.....	02	6.1 Compliance with Traffic Laws and Traffic Safety Tips	11
1.2 Parts Description.....	03	6.2 Safety Precautions about Electric Bicycle	11
2.Installation Procedure	04	6.3 Preparation for Riding	11
2.1 Handlebar Installation	04	6.4 Code Position Diagram.....	11
2.2 Front Wheel Installation.....	04	7.Battery	12
2.3 Pedal Installation.....	05	7.1 Precautions about Use of Lithium Battery	12
2.4 Headlamp Installation	06	7.2 Operating Environment.....	12
2.5 Battery Installation and Removal	06	7.3 Charging Environment.....	13
3.Battery Charging	07	7.4 Storage Environment.....	13
4.Riding Introduction	08	8.Technical Parameters	14
4.1 Riding Mode	08		
4.2 Introduction to Instrument Key Functions.....	09		
5.Use of Gearbox	10		
5.1 Diagram of Gearbox	10		
5.2 Pay Attention to the Following Details When Using the Drive System.....	10		

1. Basic Information

1.1 Unpacking Information

1x Bicycle

1x Wheel

1x Light

1x Charger

2x Pedal

1x front fender

GT Version 1x Battery

8x Tool

PRO Version 2x Keys

GT Version 4x Keys

1x User Manual



1x Bicycle



1x Wheel



1x Light



1x Charger



2x Pedal



1x Front Fender

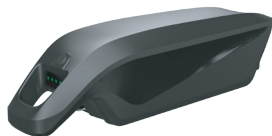

GT Version 1x Battery

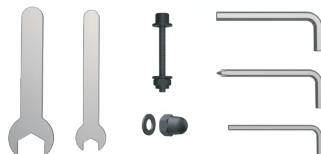

8x Tool



PRO Version 2x Key
GT Version 4x Key

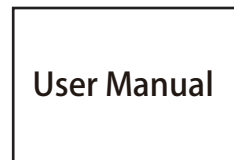

1x User Manual

1.2 Parts Description



2. Installation Procedure

2.1 Handlebar Installation

- Remove the pre-tightened set screws of the handlebar end cover using 4mm socket head wrench
- Place the handlebar, adjust it to a suitable angle, close the end cover of the handlebar and pre-tighten 4 screws using 4mm socket head wrench
- Tighten set screws of the handlebar end cover in the order of 1, 2, 3 and 4

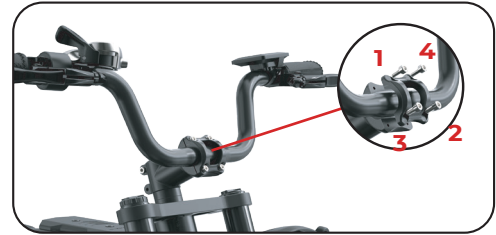
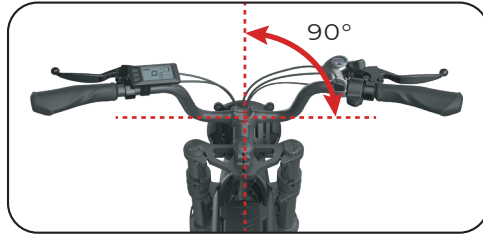
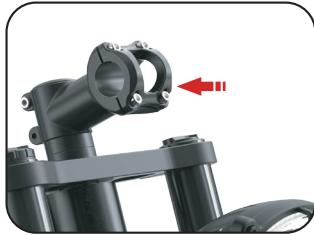

2.2 Front Wheel Installation

- Align the front disc at the space of the gateway lining, align the front axle at the front fork axle hole and insert it into the hole
- Install gaskets and cap nuts on both sides
- Tighten cap nuts on both sides using 15mm open spanner

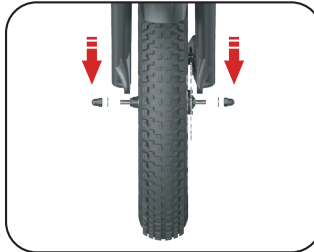

2.3 Pedal Installation

- Differentiate the identifiers of left and right pedals, L means left pedal and R means right pedal
- When installing pedals, keep the pedal bolt end face vertical to the mounting hole of the crank and tighten and fix it using 15mm open spanner
(When installing the left pedal, rotate it anticlockwise; when installing the right pedal, rotate it clockwise)

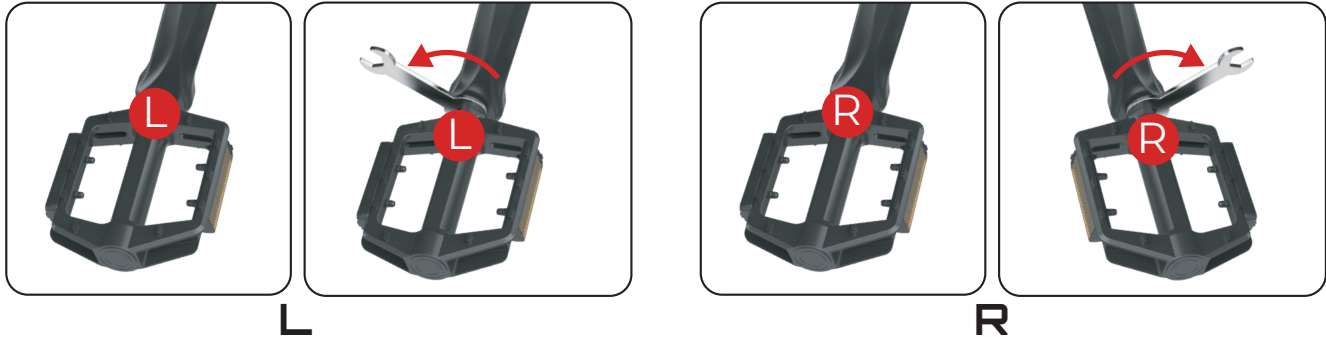
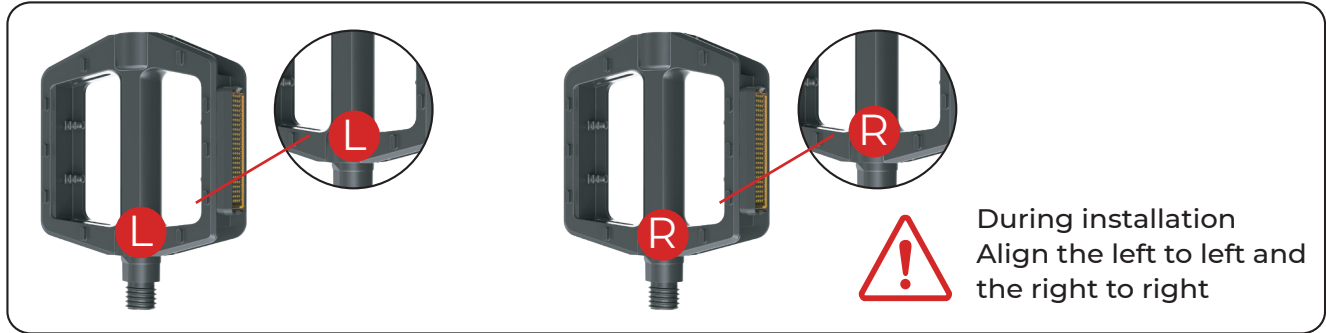

2.4 Headlamp installation

- Take the headlamp accessories out of the accessory box and install the fixed support of the headlamp;
- Adjust the headlamp angle and tighten set screws of the supports on both sides using 5mm socket head wrench;
- Connect the connecting line of the headlamp

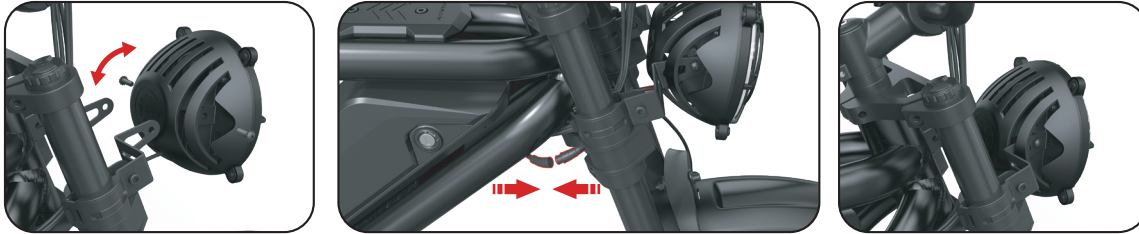

2.5 Battery Installation and Removal

- Insert the key, rotate it to ON state and place the battery in the body preset position
- Forcibly push the battery until you hear a crisp sound
- Rotate the key to Lock state and pull it out



GT version battery installation

3. Battery Charging

- Open the soft cover on the battery side
- Insert the plug of the charger into the charging port of the battery and connect the other plug to the power supply;
- The status light of the charger is red in the charging process
- After the battery is fully charged, the status light of the charger is green
- Remove the charger, keep it properly and close the soft cover after charging
- If the battery is charged on board, please power off the instrument



Charging Port Soft cover
Soft cover Charging Port

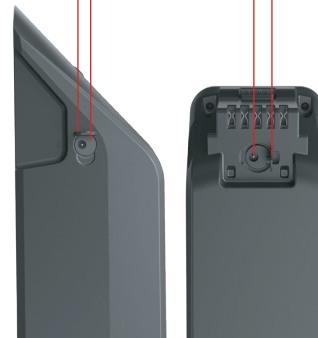

GT version battery

4. Riding Introduction

4.1 Riding mode

- In EV mode, press and hold ON. After power-off, adjust the gears (1-3) by Instrument \pm Key, and pull the speed thumb shifter to enter EV mode
- In assistant mode, press and hold ON. After power-on, adjust the gears (1-3) by Instrument \pm Key, step on the pedal for more than half a cycle to enter assistant mode
- In manual riding mode-press and hold ON. After power-on, adjust the gear (0) by Instrument \pm Key, and step on the pedal to enter manual riding mode

Note: The maximum speed at gear 1 is 12mph, that at gear 2 is 20mph and that at gear 3 is 28mph



4.2 Introduction to Instrument Key Functions

- ON/OFF: Press and hold ON for more than 2s to turn on the power; in startup state, press and hold ON for more than 2s to turn off the power;
- In startup state, short press ON/OFF, and the displayed information is switched among total distance (mileage/h), trip distance (mileage/h), riding time (h), output power (W), total distance (mileage/h), maximum speed (mileage/h) and average speed (mileage/h);
- ± key: In startup state, press and hold + for 2s to turn on the instrument backlight and turn on the headlamp. When the headlamp is turned on, press and hold for 2s to turn off the headlamp. Short press ± to switch among assistance gears (0-3) of the electric bicycle. Gear 1 means that the instrument is turned on, and gear 0 means parking mode and no motor output;

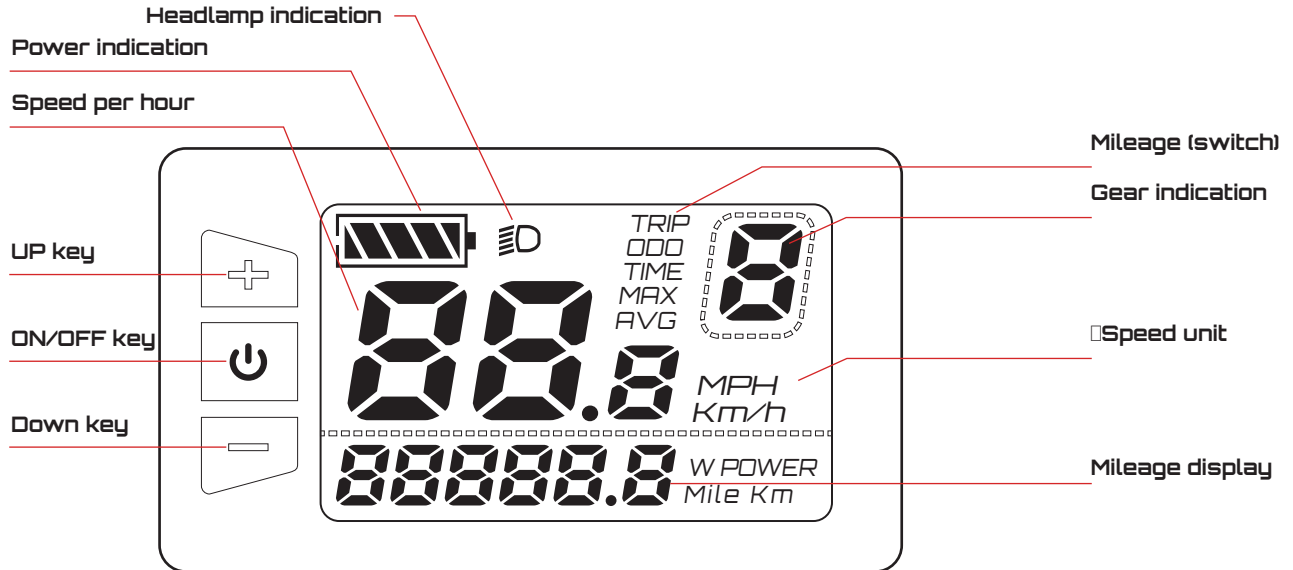

5. Use of Gearbox

5.1 Gearbox Diagram

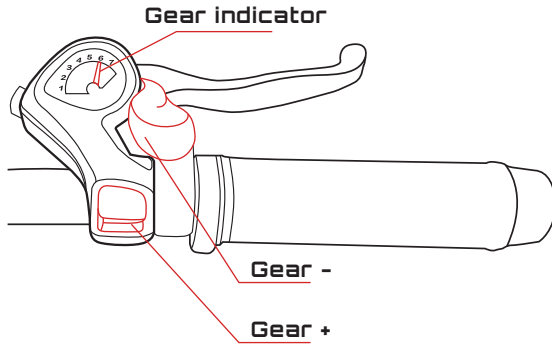

Gear	Strength	Speed
1-3	Relaxed	Slow
4-5	Moderate	Medium
6-7	Laboursome	Fast

- For acceleration, run at a low speed at first. With acceleration, switch to a high gear.
 - When driving uphill, the speed will decrease. Lower the gear to keep a certain riding speed
- It is easier to accelerate in the wind direction. Raise the gear to keep a certain riding speed
- Rising suggestions are given above, and gears can be reasonably adjusted according to personal habit

5.2 Pay Attention to the Following Details When Using the Drive System

- When using the transmission system, try not to change speed over gears to avoid damaging the gearbox. That is, do not switch more than two gears each time but gear by gear to protect the transmission system
- When the electric bicycle stops or goes downhill, do not run the drive system reversely, which may damage the drive system and cause an accident
- If the gearbox breaks down, or the gear is inaccurate, gearbox performance may be affected. In this case, timely maintain it at a repair shop to avoid aggravation of fault

6. Precautions about Use

6.1 Compliance with Traffic Laws and Traffic Safety Tips

- Do not refit the electric bicycle without permission; with maximum load of 100kg, the electric bicycle must not be overloaded
- Do not lend the electric bicycle to people who cannot drive it to avoid injury
- The electric bicycle should carry personnel or articles according to laws and regulations
- The driver must wear a helmet and be cautious when driving an electric bicycle and must not hold the handlebar by no or one hand
- Slow down during rainy and snowy weather as brake distance will extend. Then during stormy and severe weather try not to ride the electric bicycle
- When waiting for the traffic light for a long time, please adjust to gear 0, or hold the brake instead of stepping on the pedal to starting the electric bicycle

6.2 Safety Precautions about Electric Bicycle

- Do not park an electric bicycle in the lobby, escape stair, passage and emergency exit of buildings
- Do not charge and park the electric bicycle in a residential building, keep far away from combustibles in the charging process and do not charge the electric bicycle for a long time
- Correctly use and maintain the batteries. Waste batteries should not be dismantled arbitrarily and should be recycled by related departments
- Understand safe use methods and warning signs of charger
- The charger should match the battery
- To avoid an accident potential caused by wetting of internal electronic parts and circuits, do not wash an electric bicycle with water
- When adjusting the handlebar or the saddle, safety signs of handlebar pipe and saddle pipe should not be exposed (if applicable)

The electric bicycle should be regularly maintained.

It should be maintained twice and complex parts should be taken care by a repair shop

6.3 Preparation for Riding

- Check whether the power circuit and the light are normal;
- Check whether the front and rear brakes work normally;
- Check whether the handlebars and front and rear wheels are tightened;
- Whether the tire pressure is normal; (see the tire label)
- Check whether the reflector is damaged or polluted before driving;

6.4 Code Position Diagram

XXXXXXXXXXXXXXXXXX



(Front of frame controller box)

7. Battery

7.1 Precautions about Use of Lithium Battery

- Confirm the battery model if it's original. Do not use batteries of other brands without permission
- Check whether the lithium battery is intact and has damage, leakage, heat emission, moisture, smoke and other obvious phenomena
- To ensure transportation safety, the battery quantity is about 30% upon delivery. Due to power consumption during transportation and storage, it is normal that the battery quantity is low or the battery has run out of power when used for the first time.

Please charge the battery for 24h when it is used for the first time after purchased or stored for a long time

7.2 Operating Environment

- The optimal operating temperature is 10°C-45°C
- The battery capacity may decrease in varying degrees at low temperature as follows

The available capacity is about 70% at -10°C, about 85% at 0°C and about 100% at 25°C; if the battery gives out peculiar smell, emits heat, deforms and has other abnormal conditions, please immediately stop using it, keep far away from it and contact the after-sales service department

Warning

Battery is not a repairable part. In case of abnormalities, the battery may emit heat, give out smoke and cause a fire and explosion.

7.3 Charging Environment

- Charge the battery using original charger instead of charger of other brands or models
- Please charge the battery at 0°C -40°C in a well-ventilated place and keep off combustibles
- Charging time: Do not charge the battery for more than 12h; otherwise, the battery life will be affected and a potential safety hazard will be caused
- The battery capacity will rise quickly in the early charging process and then slow down, which is a normal procedure to ensure safety
- Do not charge the battery outdoors in severe weather
- If the surface temperature of the battery box is very high (higher than 55°C) in the charging process, it indicates that the battery box breaks down and should be immediately powered off and sent to the designated repair station. It is normal that the charger box is slightly hot (no more than 60°C) in the charging process

7.4 Storage Environment

- After the battery is installed, the battery capacity will be slowly consumed when the electric bicycle runs. The fully charged battery can be placed for no more than two months and it is normal that the instrument displays a drop of battery capacity
- When the battery is left unused for a long time (more than a month), please be sure to remove it from the electric bicycle and charge the battery to half-saturated state (after fully discharged, charge the battery for 1.5-2h using charger). Then, store the battery in a cool and dry place (the optimal temperature is 5°C -25°C) and charge it for about 3h every two months
- The battery and the charger should be stored in clean, dry and well-ventilated place and far away from corrosive substances, ignition and heat sources (no less than 2m) and combustibles and they should be disconnected
- The optimal battery capacity is 50%. If the battery is stored for a long time when the capacity is lower than 10% or higher than 90%, the capacity will decrease irreversibly
- Do not store the battery in a high place, since drop may cause uncontrollable internal damage, leakage, heat, smoke, fire or explosion to battery
- The electric vehicle and battery should be protected from rain, ice, snow and chemical substance when used and stored and must not be washed with water to avoid an accident potential caused by wetting of internal electronic parts and circuits

8. Technical Parameters

The endurance mileage is measured when the battery is fully charged, at load of 70kg, temperature of about 25°C, gear 1 and constant speed of 12mph, on flat road surface, in a windless environment. Actual endurance mileage may differ with load, temperature, wind speed, road surface, operating habit and other factors.

Product name	Bullet PRO	Bullet GT
Net weight	37kg	40kg
Product size	1720*670*1055mm	1720*670*1055mm
Packaging box size	1500*375*820mm	1500*375*820mm
Maximum gradient	15° (load 100kg)	15° (load 100kg)
Load	265lb./100kg	265lb./100kg
Maximum speed	28mph/45km/h	28mph/45km/h
Endurance mileage	31miles/50km	43miles/70km
Motor	750W	750W
Battery capacity	48V20Ah	48V28Ah
Charging voltage	90-264V	90-264V
Wheel diameter	20in.	20in.
Charging time	7 hours	9.5 hours
Waterproofing grade	IPX4	IPX4
Storage temperature	20°C-25°C/68°F-77°F	20°C-25°C/68°F-77°F
Operating temperature	-4°F-140°F/1-20°C~60°C	-4°F-140°F/1-20°C~60°C
Charging temperature	32°F-104°F/0°C-40°C	32°F-104°F/0°C-40°C
Warranty	1 Year Limited	1 Year Limited

RAEV

Company: E-LINK TECHNOLOGY CO.,LTD

Address: 4~5F/ B Block, Ding Bao Hong Green High-Tech
Park No.8 Industrial 2nd Road, ShiYan BaoAn District,
Shenzhen, China.

Email: support@raevbikes.com

Website: raevbikes.com

Made In PRC

FC RoHS REACH  