

## Central hydraulic pump, replacing

### Work sequence

- prior to removing old pump, bleed the hydraulic accumulator by pumping the brake pedal 20 to 25 times with the engine off
- loosen pump pulley bolts and pump bracket bolts
- remove hydraulic lines from pump
- remove pump from vehicle with brackets and pulley attached

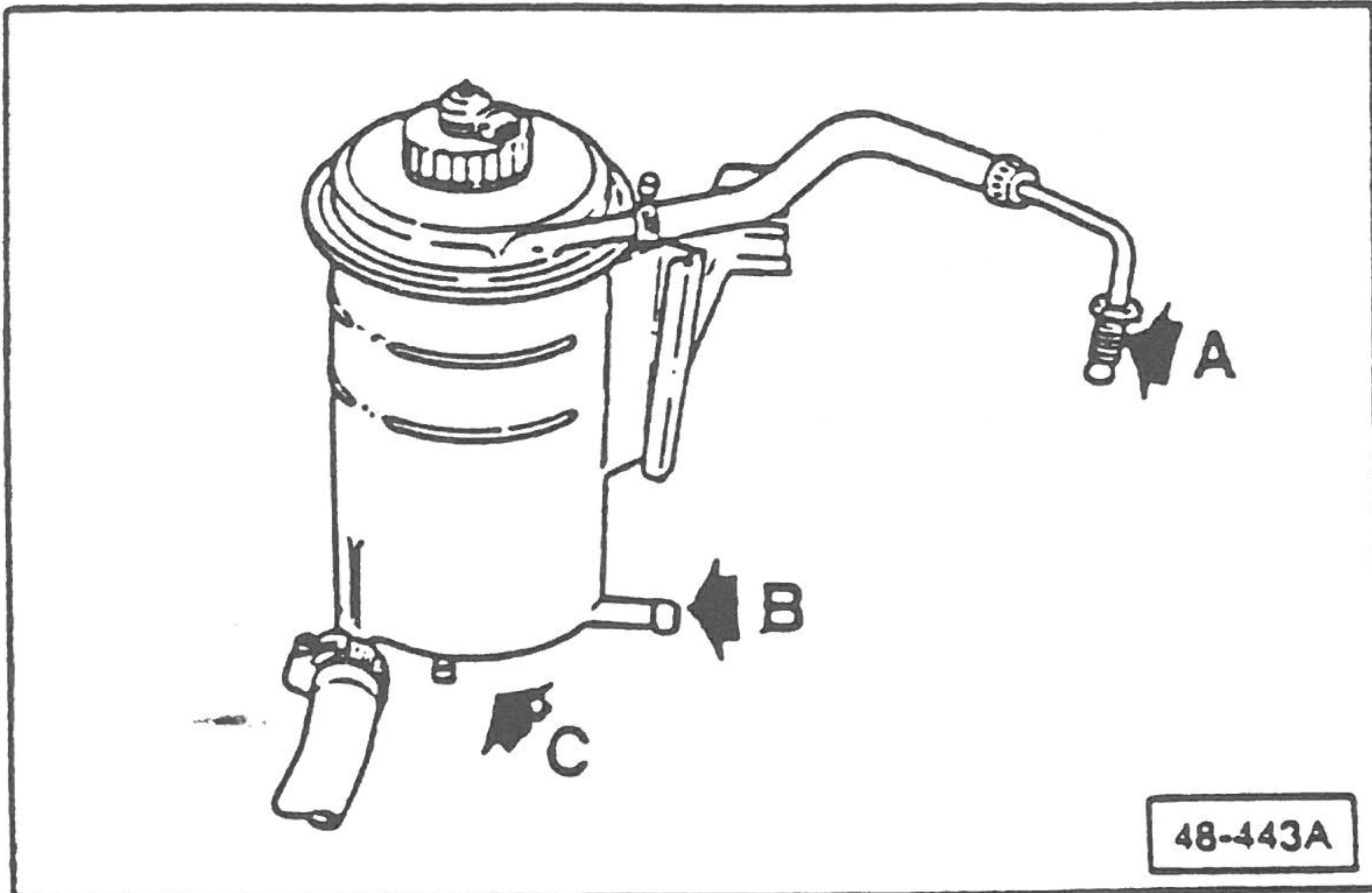

- unbolt return line from hydraulic brake servo to reservoir at the servo (arrow A)
- remove clamp from steering gear return hose at reservoir and carefully pull hose off (arrow B)
- remove nuts and washers holding reservoir bracket to engine compartment panel and pull reservoir assembly out toward front of vehicle
- unfasten accumulator hose at bottom of reservoir and pull hose off (arrow C)
- remove reservoir with bracket and two hoses attached
- wash out reservoir, strainer and attached hoses, with clean solvent

### Note

If the strainer cannot be thoroughly cleaned or is damaged, replace it with a new part. Use the newer version strainer, Part No. 443 422 385A.

- install reservoir assembly in vehicle and attach hoses and lines disconnected during removal
- assemble pump brackets and pulley to new pump

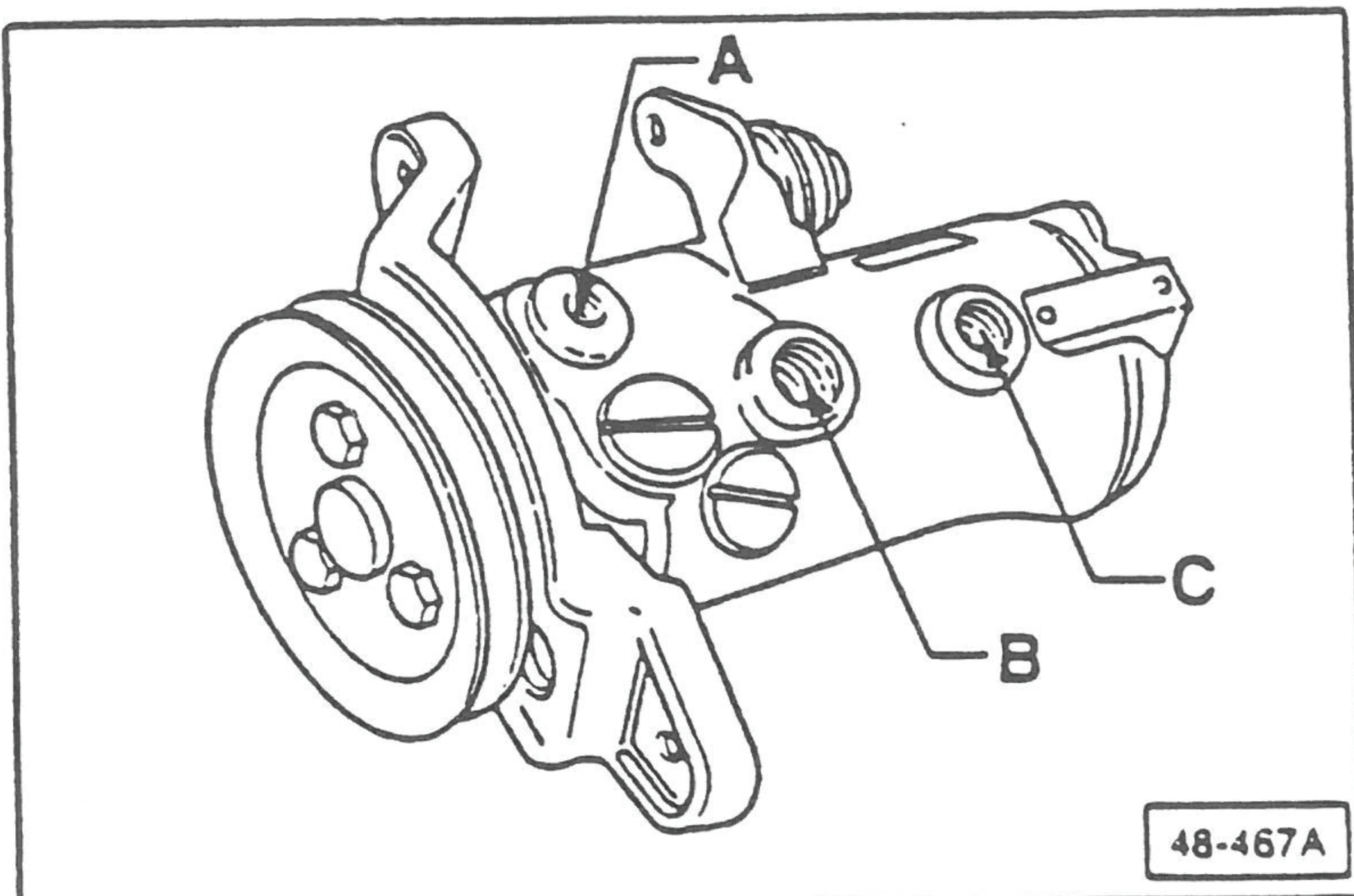

- pour some hydraulic fluid into outlet port (arrow A) and rear chamber (arrow C) of new pump
- fill suction chamber (arrow B) with hydraulic fluid
- rotate pump slowly by hand through four to five complete revolutions (fluid will be discharged at arrow C). Keep suction chamber (arrow B) full of fluid
- install new hydraulic pump in vehicle
- separate pump to accumulator line at fitting and check if damper hose is missing or restricted

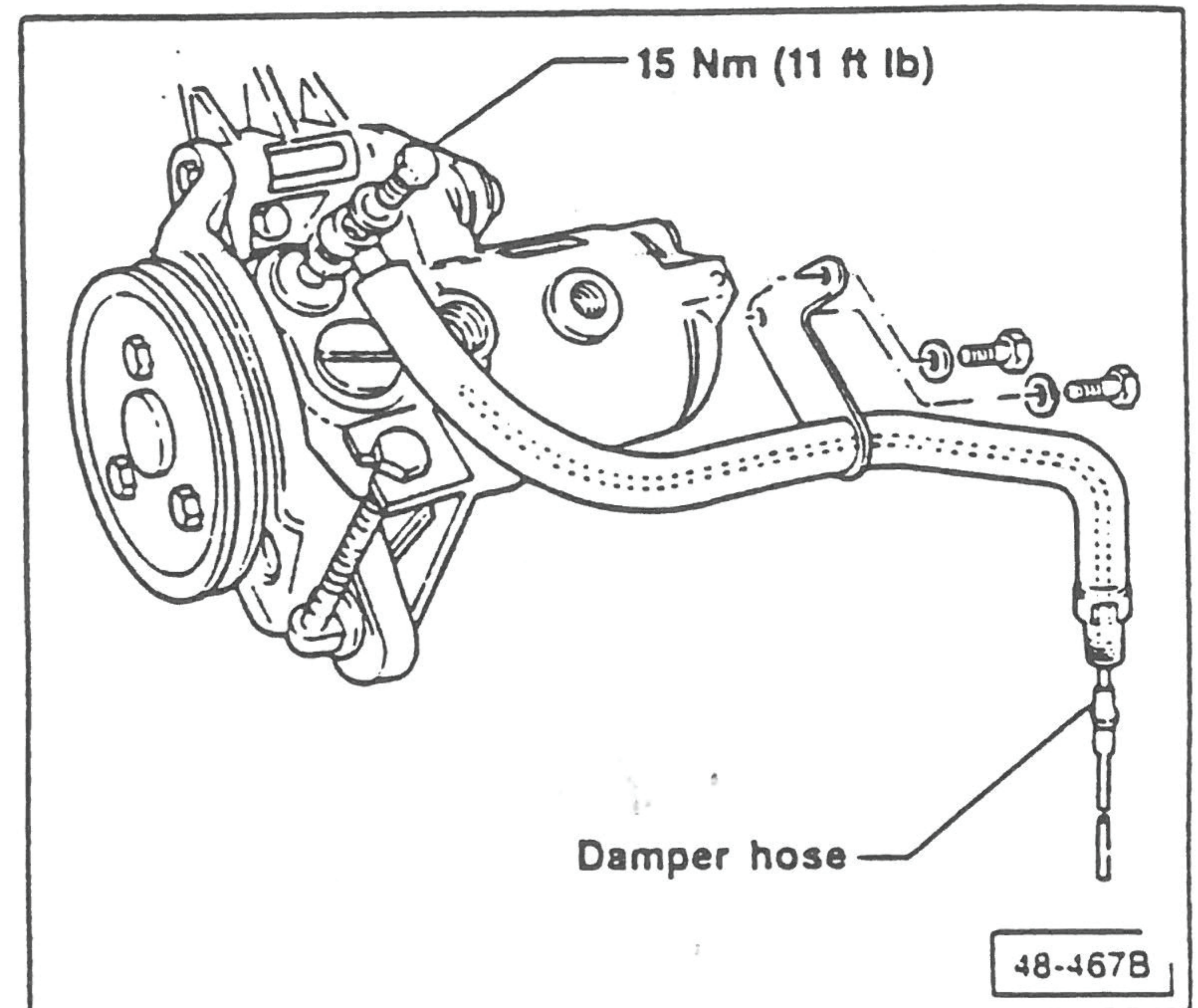

- reassemble accumulator line and connect to pump

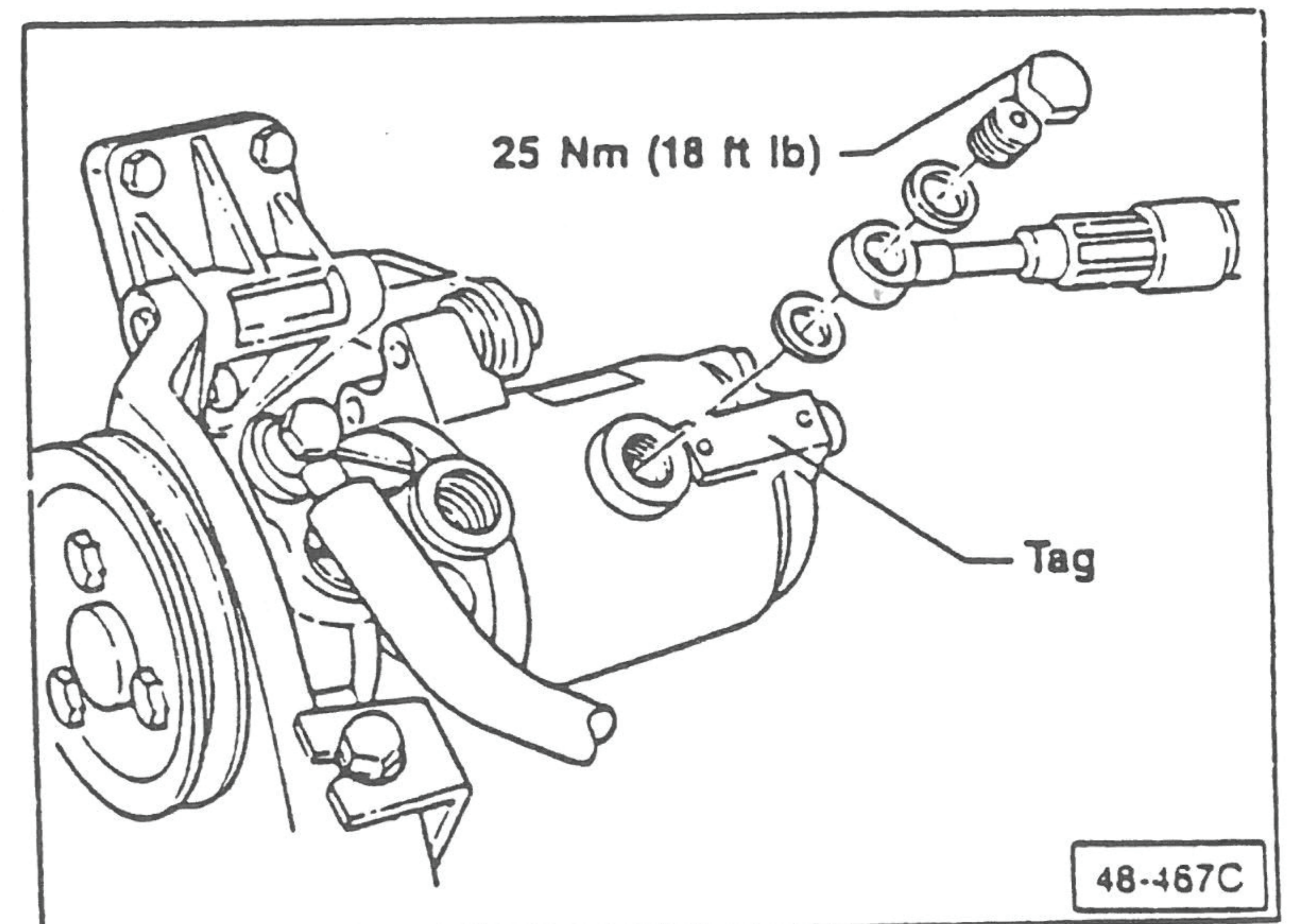

- connect pressure line to pump using correct banjo bolt:

### Rear chamber port

- pump with red tag:  
use banjo bolt with small hole  
Part No. N 903 246.01
- pump with silver tag:  
use banjo bolt with three large holes  
and no screen  
Part No. N 021 071 2



- connect suction line to pump using correct banjo bolt:

(COURTESY OF AUDI OF AMERICA)