

## **NWUPCM-1P SERIES USER MANUAL**

# PHASE ANGLE SCR POWER CONTROL DRIVER BOARD FOR RESISTIVE LOADS

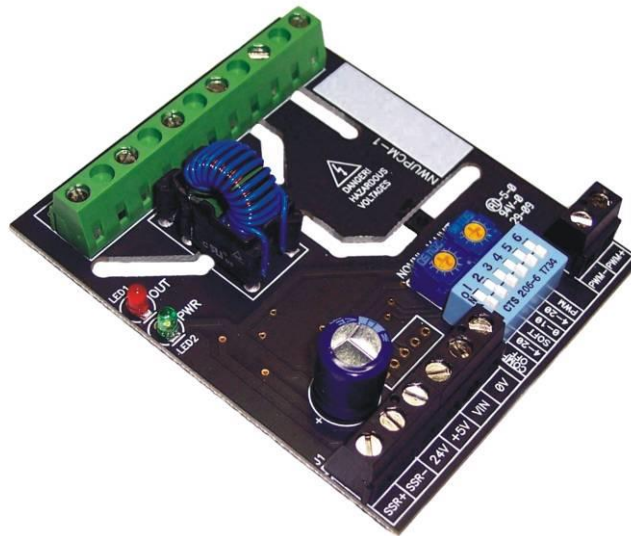
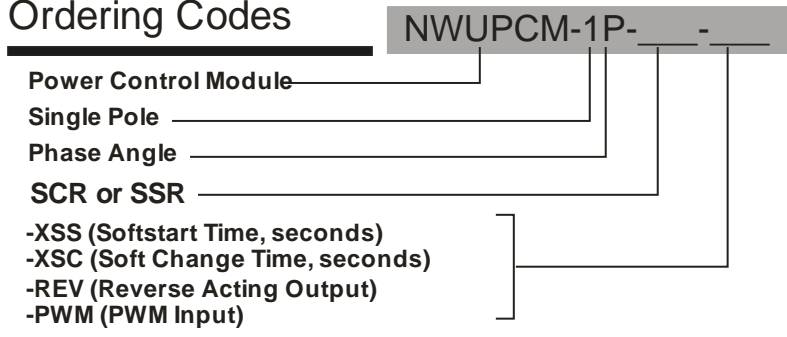

**TABLE OF CONTENTS**

1.	Ordering Codes.....	3
2.	Description .....	3
3.	Installation / Safety Information.....	3
3.1	Mounting Instructions.....	4
3.2	Electrical Connections .....	4
3.3	SCR Output Snubbers and Transient Protection .....	4
3.3.1	Commutation Problems .....	4
3.3.2	dv/dt Problems.....	4
3.3.3	Snubber Sizing .....	4
3.3.4	MOVs and TVSs.....	5
3.4	Limited Warranty.....	5
4.	Operation .....	5
4.1	Power Supply.....	5
4.2	24V Power Fusing.....	5
4.3	Command Input .....	5
4.4	PWM Command Input.....	6
4.4.1	PWM Input.....	6
4.4.2	Input Fail-safe Protection.....	6
4.5	Line Voltage Compensation.....	6
4.5.1	Line Voltage Compensation Nominal Adjustment.....	6
4.6	Soft Start.....	6
4.7	Voltage Limit .....	7
4.7.1	Voltage Limit Adjustment Procedure.....	7
4.8	Configuration Dipswitch .....	7
4.9	SSR Drive Output (NWUPCM-1P- SSR).....	8
4.10	Output LED .....	8
4.11	Three Phase Operation.....	9
4.12	Wiring Multiple Units in Single Phase or Three Phase Applications.....	9
4.12.1	Connecting Power & Commands In Parallel.....	9
5.	Electrical Specifications .....	9
6.	Mechanical Dimensions .....	10
7.	WIRING DIAGRAM - SINGLE PHASE (SSR OR SCR).....	11
8.	WIRING DIAGRAM 3 INSIDE DELTA CONNECTION (SSR).....	12
9.	WIRING DIAGRAM 3 PHASE 4 WIRE Y CONNECTION (SSR).....	13
10.	WIRING DIAGRAM 3 PHASE 4 WIRE Y CONNECTION (SCR).....	14
11.	WIRING DIAGRAM 3 PHASE INSIDE DELTA CONNECTION (SCR).....	15

## 1. Ordering Codes

### Ordering Codes



Part#	Description
NWUPCM-1P-SSR	Phase Angle Control Module SSR DRIVE
NWUPCM-1P-SCR	Phase Angle Control Module SCR GATE DRIVE
NWUPCM-1B-SSR	Burst Firing Control Module SSR DRIVE (see NWUPCM-1B User Manual)
NWUPCM-1B-SCR	Burst Firing Control Module SCR GATE DRIVE (see NWUPCM-1B User Manual)
NWUPCM-1B-SSR-LVC	Burst Firing Control Module SSR DRIVE (see NWUPCM-1B User Manual)
NWUPCM-1B-SCR-LVC	Burst Firing Control Module SCR GATE DRIVE (see NWUPCM-1B User Manual)

## 2. Description

The NWUPCM-1p is a Phase Angle SCR Power Control Driver Board designed for use with Solid State Relays or high power back to back SCR modules. The power delivered to the load is proportional to the command input signal.

Features:

- Provides true linear power output phase angle control and burst fire control
- Small 3.0"x2.5" module mounts in a snap track or a dinrail
- Command input accepts 4-20mA, 0-10V, 0-5V, Pot, PWM
- Configurable line voltage compensation increases stability of your process
- Configurable soft start for high inrush loads
- Wide frequency operation (30 to 90Hz)
- Adjustable Voltage Limit
- Drives multiple solid state relays
- Drives SCR gates directly
- Single phase and three phase control

## 3. Installation / Safety Information

Responsibility for determining suitability for use in any application / equipment lies solely on the purchaser, OEM and end user. Suitability for use in your application is determined by applicable standards such as UL, cUL and CE and the completed system involving this component should be tested to those standards.



**WARNING: FIRE HAZARD!!** Even quality electronic components CAN FAIL KEEPING FULL POWER ON! Provide a SEPARATE (redundant) OVER TEMPERATURE SHUTDOWN DEVICE to switch the power off if safe temperatures are exceeded.

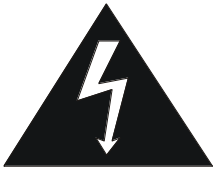

**WARNING: HIGH VOLTAGE!!** This control module has high voltage on it. This control must be installed in a **GROUND**ED enclosure by a qualified electrician in accordance with applicable local and national codes including NEC and other applicable codes. Provide a safety interlock on the door to remove power before gaining access to the device.



The NWUPCM-1 contains fragile components that if damaged can cause improper operation, failure or fire. While all units are inspected and tested at the factory, damage can occur during shipping or installation. Before applying power, inspect each module for damage paying specific attention to the pulse transformer drive coil. If there are any abrasions or scratches on the coil wires, **DO NOT APPLY POWER**. The unit should be sent back to the factory for repair.

### **3.1 Mounting Instructions**

The NWUPCM-1 mounts in a 3.0" snap track and can be installed on a dinrail.

### **3.2 Electrical Connections**

See the **WIRING DIAGRAMS** at the end of this document. Make sure the module ordered is the correct module for the application before wiring. Before wiring the module all Dip Switch settings for the command input and special features should be setup properly per the Dipswitch Configuration Section.

### **3.3 SCR Output Snubbers and Transient Protection**

#### **3.3.1 Commutation Problems**

When an SCR or TRIAC is used to control an inductive load, the load current lags the mains voltage. When the device turns off at zero current, the rate of rise of the reapplied voltage can retrigger the device and produce half cycling and blown fuses. To limit this rate of rise and obtain reliable commutation, an R-C (resistor–capacitor) snubber circuit should be connected in parallel with the SCR/TRIAC.

#### **3.3.2 dv/dt Problems**

When voltage transients occur on the mains supply or load of an SCR/TRIAC it can cause the device to turn on unexpectedly due to the fast rate of rise of voltage (dv/dt). This can result in false firing and half cycling of the load that can cause blown fuses when driving inductive loads. An R-C snubber circuit will help to limit the dv/dt seen by the device and will produce more reliable firing.

#### **3.3.3 Snubber Sizing**

When an SCR/TRIAC using an R-C snubber turns on, the capacitor is discharged through the resistor into the device resulting in high peak currents. It is critically important when sizing your snubber to make sure that the resistor value does not become so low that the ratings of the SCR/TRIAC are exceeded when the capacitor is discharged.

### **3.3.4 MOVs and TVSs**

Metal Oxide Varistors and Transient Voltage Suppressors are both used on TRIACS/SCRs to “clamp” voltage spikes that can occur across the devices and damage them. Snubbers are not a substitute for MOVs/TVSs and vice versa. Snubbers and MOVs/TVs should be used together to get reliable performance and long life from the SCR/TRIAC application. External MOVs must be installed across the SCRs to limit peak voltages accepted by the NWUPCM to ~ 850VDC.

## **3.4 Limited Warranty**

NuWave Technologies, Inc. warrant this product to be free from defect in workmanship and materials for a period of two (2) years from the date of purchase.

1. Should unit malfunction, return it to the factory. If defective it will be repaired or replaced at no charge.
2. There are no user serviceable parts on this unit. This warranty is void if the unit shows evidence of being tampered with or subjected to excessive heat, moisture, corrosion or other misuse / misapplication.
3. Components which wear or damage with misuse are excluded, e.g. relays.
4. NuWave Technologies, Inc. shall not be responsible for any damage or losses however caused, which may be experienced as a result of the installation or use of this product. NuWave Technologies, Inc. liability for any breach of this agreement shall not exceed the purchase price paid E. & O.E.

## **4. Operation**

### **4.1 Power Supply**

The NWUPCM-1 power supply requirement is 24V AC +/-10% 47-63Hz. The line synchronization for phase angle and certain modes of burst firing has an input voltage range of 100 to 600VAC, 30 to 90Hz.

### **4.2 24V Power Fusing**

Fusing may be accomplished by fusing each module separately or fusing groups of the modules with either primary or secondary fusing. The current draw of each NWUPCM-1 is 100mA max.

### **4.3 Command Input**

The NWUPCM-1 can accept 4-20mA, 0-10V, 0-5V, and Potentiometer and PWM inputs. All analog command inputs are not isolated from the 24V power Input. The type of command input can be configured via the dipswitch. The default setting is 0-5V/potentiometer.

The PWM digital command input (PLC Interface) is optically isolated from the power supply.

When wiring multiple NWUPCM-1's together, follow the guidelines in the Wiring Multiple NWUPCM-1s section.

Any leg of the command input can tolerate shorts to the (0V) input. Connecting the 24V power to the command input may cause damage to the unit.

## 4.4 PWM Command Input

The NWUPCM-1 PWM Command input is designed to accept a signal from a PLC or a process/temperature controller's SSR drive output. This logic signal is used to generate a command setpoint.

### 4.4.1 PWM Input

The NWUPCM-1 accepts PWM signals from 500Hz-15KHz and logic voltages of 5VDC (non isolated command input) or 24VDC (optically isolated PWM input). When using the optically isolated PWM input, the PWM Dip Switch #6 must be set to "ON". The PWM input provides a low cost way to interface with a PLC or PC DAQ.

### 4.4.2 Input Fail-safe Protection

If the signal sent to the NWUPCM-1's command input should become electrically open the control output will be forced to an off state.

## 4.5 Line Voltage Compensation

The NWUPCM-1's line voltage compensation keeps the power constant on the load as the line voltage changes. The line voltage is measured via the 24V power applied to the NWUPCM-1 module. To use the Line Voltage Compensation feature properly, a 24VAC power transformer should be fed from the same mains as the load circuit to be controlled as per the wiring diagrams at the end of this document. Line Voltage Compensation can be enabled or disabled using the configuration dipswitch. The default setting is enabled (Switch # 1 is OFF). To disable the Line Voltage Compensation, set switch # 1 to the ON position.

With a 10% drop in line voltage, NWUPCM-1 load power drops less than 2%

(120V, 1KW, 14.4 Ohm Load )

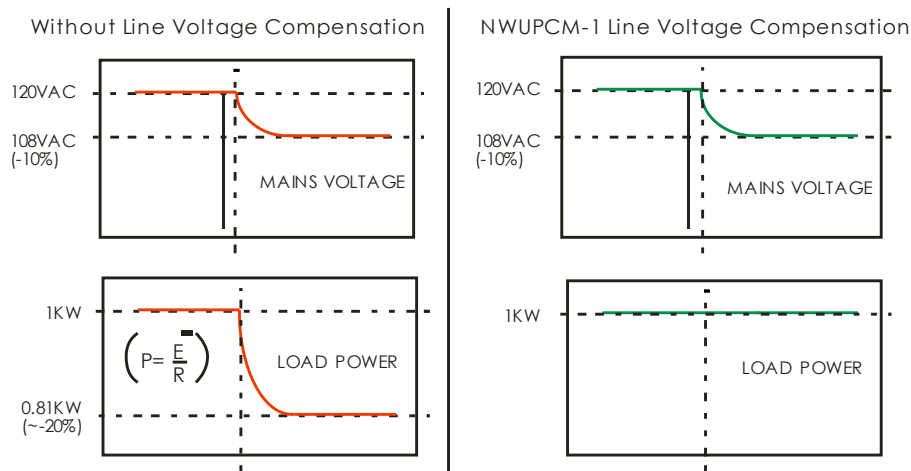

### 4.5.1 Line Voltage Compensation Nominal Adjustment

The nominal adjustment pot sets the nominal level of output for the current line voltage being measured via the 24VAC input.

## 4.6 Soft Start

The Soft Start feature ramps up to the command value over a period of approximately 5 seconds (at 60Hz). The soft start time resets if the command value goes to zero (less than 4% of the input range) or power is cycled. Soft start is useful on high inrush heaters such as Quartz, Molybdenum, Tungsten, or Graphite heaters.

Soft Start can be set on or off using the configuration dipswitch. The default setting is off. Soft start times below 5 seconds are available and can be ordered by adding a “-XSS” to the ordering code where X is the time in seconds.

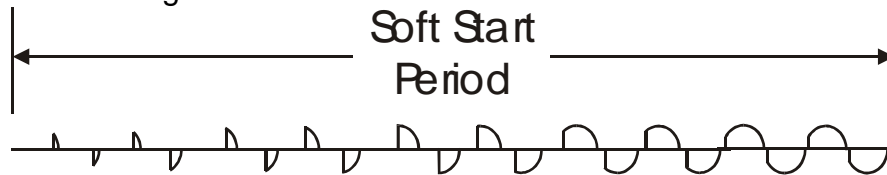

*The Soft Start ramps the voltage up slowly over the soft start period.*

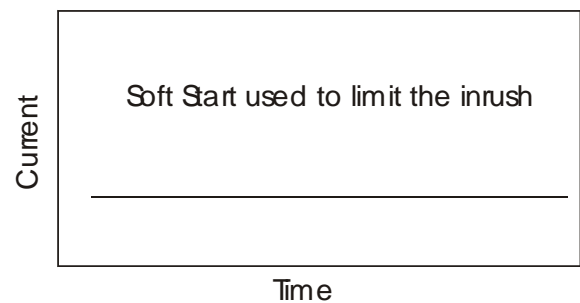
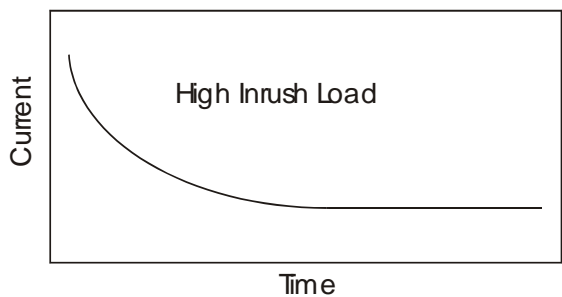

## 4.7 Voltage Limit

The Voltage Limit feature is used in conjunction with the Line Voltage Compensation feature to limit the actual voltage delivered to the load. The Voltage Limit is adjustable via a potentiometer located just below the input terminal block. For this feature to work properly Line Voltage Compensation must be turned on and the power transformer for the NWUPCM-1 must be connected to the same mains as the load power is connected to. This feature can be used without Line Voltage Compensation and will simply clip the command signal to a set level.

### 4.7.1 Voltage Limit Adjustment Procedure

The Voltage Limit is adjustable from 25% to 100% of the max load voltage. Setting the Voltage Limit potentiometer half way corresponds to a power limit of approximately 55% or a voltage limit of 70% of the max load voltage. The best way to set the voltage limit is using a voltmeter connected across the load. With the command input set to approximately 100% (on startup) turn the pot fully CCW. Then just turn the pot CW until the desired output voltage is achieved. For this feature to work as a true voltage limit, it is important that the Line Voltage Compensation be enabled (this is the OFF position of Switch # 1).

If the line voltage compensation is set to OFF the voltage limit will act as a percentage of output limit and the absolute voltage limit will change with line voltage.

## 4.8 Configuration Dipswitch

The configuration dipswitch is used for setting up the command input, line voltage compensation and soft start. Using a pen point gently push the switch up for on and down for off according to the setup outlined in the table below.

Command Input	2	4	5	6
<b>0-5V (Default)</b>	OFF	OFF	OFF	OFF
<b>Potentiometer</b>	OFF	OFF	OFF	OFF
<b>0-10V</b>	OFF	<b>ON</b>	OFF	OFF
<b>4-20mA</b>	<b>ON</b>	OFF	<b>ON</b>	OFF
<b>1-5V</b>	<b>ON</b>	OFF	OFF	OFF
<b>2-10V</b>	<b>ON</b>	<b>ON</b>	OFF	OFF
<b>PWM (isolated input)</b>	OFF	OFF	OFF	<b>ON</b>

Feature to Enable	1	3
<b>Line Voltage Comp Enabled (default)</b>	OFF	OFF
<b>None</b>	<b>ON</b>	OFF
<b>Soft Start Only Enabled</b>	<b>ON</b>	<b>ON</b>
<b>Soft Start &amp; Line Voltage Comp Enabled</b>	OFF	<b>ON</b>

#### 4.9 SSR Drive Output (NWUPCM-1P- SSR)

The NWUPCM-1's SSR output drive is a DC-pulsed current limited 10V/15mA (nominal) drive signal. This is more than enough current for driving most 3-32V standard SSRs, however it is still important to review the data sheet for the SSR you would like to use for compatibility with the NWUPCM-1's output drive. The control output can tolerate a momentary direct short. The following graph will allow you to verify the SSR's compatibility with the NWUPCM-1 over wide input voltage variations.

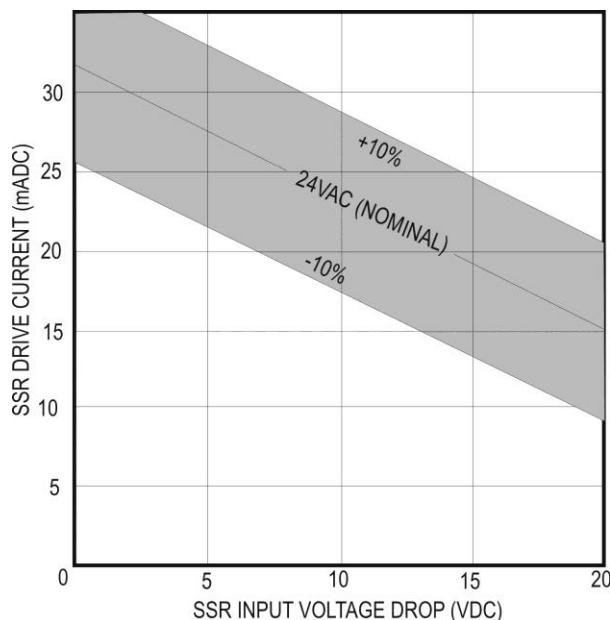

NWUPCM-1's Output Drive Current vs. SSR Input Voltage Drop

#### 4.10 Output LED

The NWUPCM-1's RED output LED will turn on when the output is on and increase in intensity as the power output is increased. Because the drive signal varies considerably to give linear power output, the LED should only be used as a rough indication of SSR/SCR Drive and not actual power output.



## 4.11 Three Phase Operation

Three NWUPCM-1s can be used to control three poles of a three phase load for inside delta, or grounded WYE configurations. The Module should be wired as shown in the wiring diagrams.

## 4.12 Wiring Multiple Units in Single Phase or Three Phase Applications

If more than one NWUPCM-1 is to be used from a non-isolated or common command signals:

1. A common power supply or transformer can be shared. If the input selected is 0-10V or 0-5V, the inputs should be wired in parallel.
2. If multiple units must be powered from one power transformer and 4-20mA input is selected, one module should be set for 4-20mA and the remaining modules should be set for 1-5V and wired in parallel.
3. If the command is 4-20mA, and the command inputs are to be wired in series, a separate power transformer or supply for each module is required to isolate the inputs.

### 4.12.1 Connecting Power & Commands In Parallel

When multiple NWUPCM-1 power inputs and commands are wired in parallel, all of the 0V terminals must be connected together follows:

Power:	Command:
0V-----0V-----0V----->	0V-----0V-----0V----->
24V---24V---24V--->	IN-----IN-----IN----->

No crossing of the power input feed or command signal is permitted. If for some reason the power should become crossed, it will cause a direct short in the system. If properly fused, the fuse will blow and the NWUPCM-1 will not be damaged. If the command inputs are wired improperly, damage to the NWUPCM-1 can result.

## 5. Electrical Specifications

Command Inputs	4-20mA, 0-10V, 0-5V, Pot, PWM
Input Impedance	10K $\Omega$ (0-10V), 250 $\Omega$ (4-20mA), 100K $\Omega$ (0-5V)
Control Output	SSR Drive, DC pulse, nominally 10V at 15mA
Response Time	<50mS
PWM Input Frequency	500Hz-15KHz
PWM Input Level	5 VDC (non isolated) or 24VDC (isolated)
Output Linearity	+/-3%
External Potentiometer Res.	10K $\Omega$ -25K $\Omega$
Line Voltage Comp. Range	+15%/-15% up to 100% output
Regulation	+/-3%
Soft Start Period	5 seconds to reach 100% output
Voltage Limit Range	25-100% of max load voltage.
Ambient Temperature Range	0 to 50 $^{\circ}$ C
Power Supply	24VAC +10/-10%, <100mA Current Draw.
Line Frequency Range	30 to 90Hz
Line Voltage Range	100-600VAC (External MOV must be installed across SCRs to limit peak voltages to ~ 850VDC)
SCR Gate Drive Characteristics	16KHz Burst for 1.35mS every half cycle. Initial pulse peak current of 600mA, maintain pulses, 300mA, 10uS pulse width per pulse, rise time of 100nS.

## 6. Mechanical Dimensions

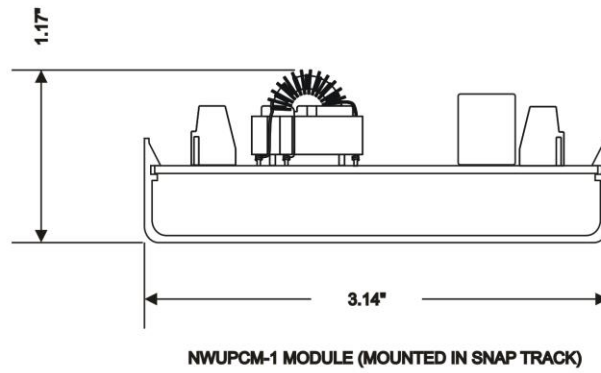
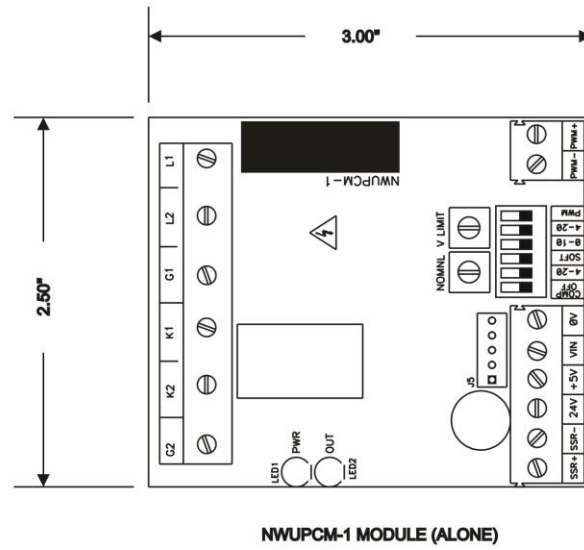

	<b>NWUPCM-1 DIMENSIONS</b>
	<b>Revision. 0</b>
	<b>DC 072809</b>

## 7. WIRING DIAGRAM - SINGLE PHASE (SSR OR SCR)

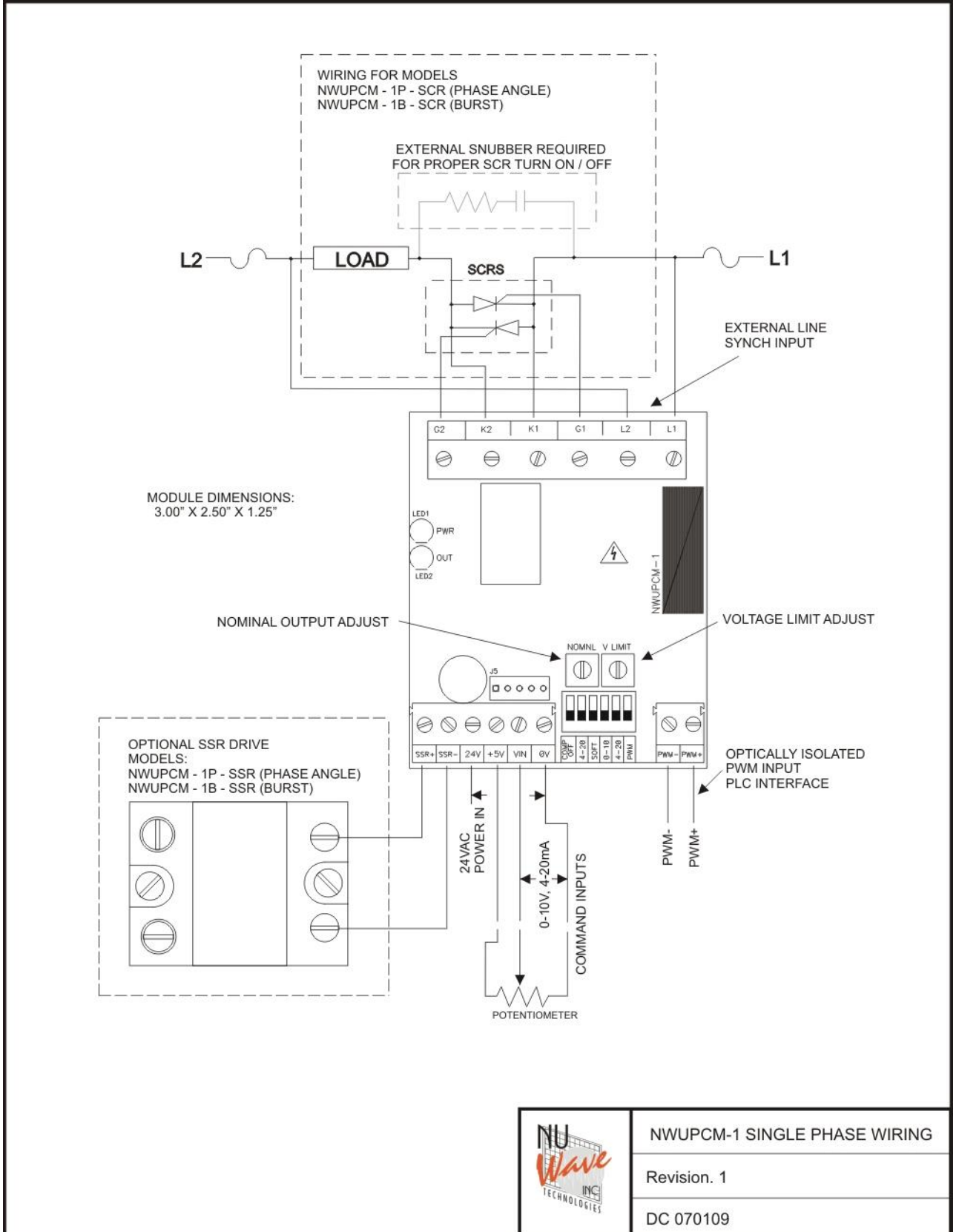

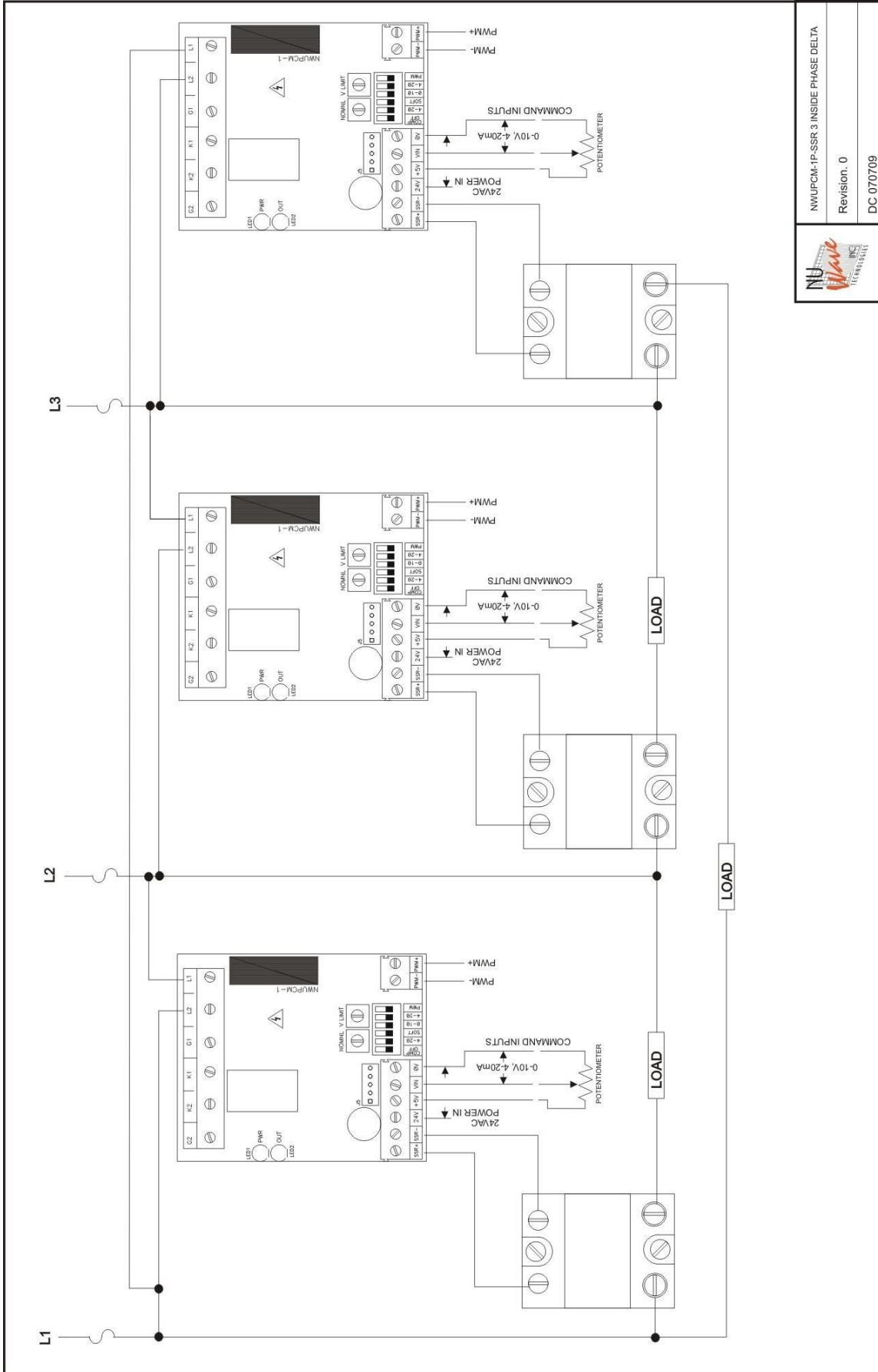

## 8. WIRING DIAGRAM 3 INSIDE DELTA CONNECTION (SSR)

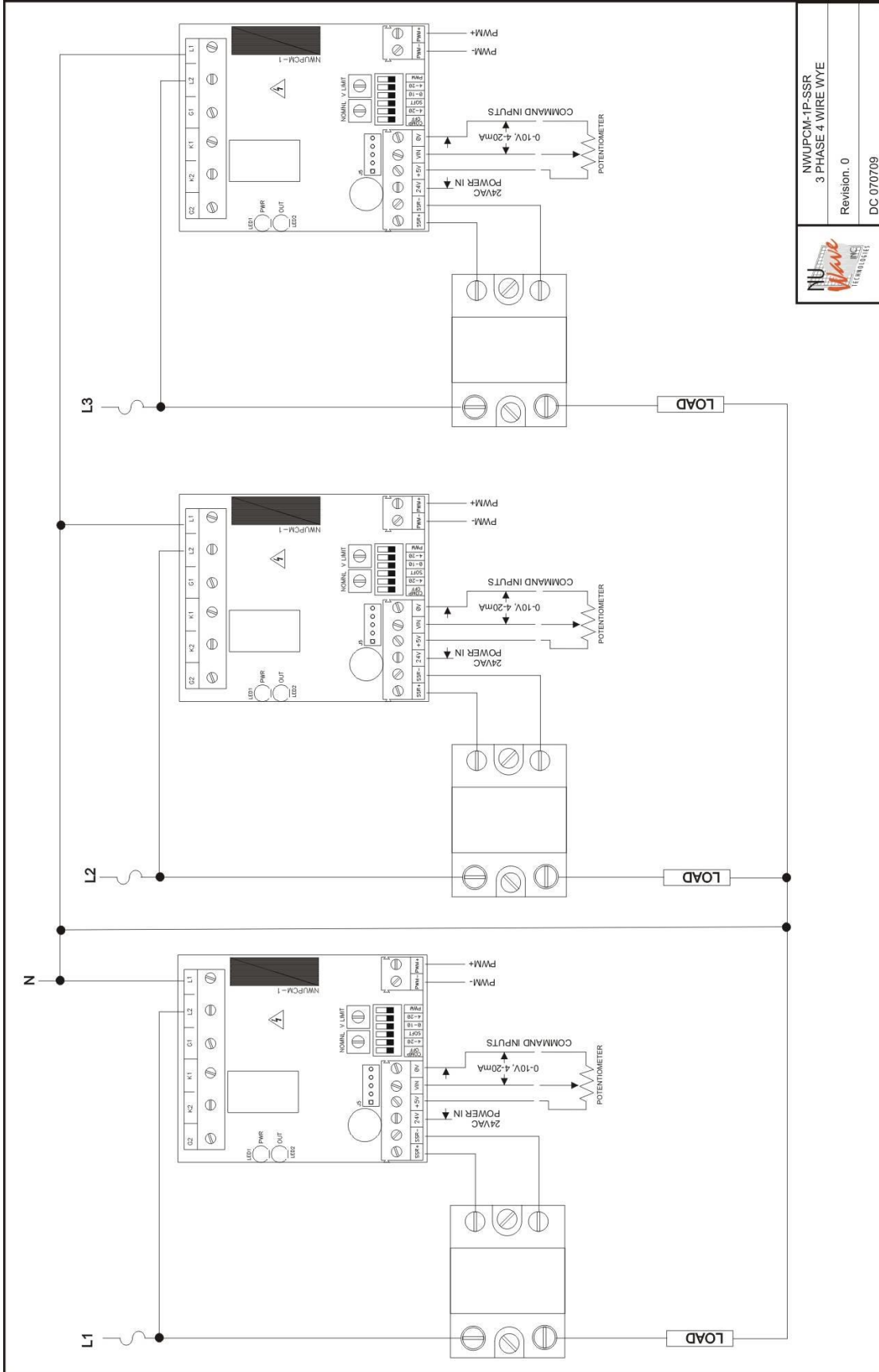

	NWUPCM-1P-SSR 3 INSIDE PHASE DELTA
	Revision: 0
	DC 070709

## 9. WIRING DIAGRAM 3 PHASE 4 WIRE Y CONNECTION (SSR)





NWUPCM-1P-SSR  
 3 PHASE 4 WIRE WYE  
 Revision: 0  
 DC 070709

# 10. WIRING DIAGRAM 3 PHASE 4 WIRE Y CONNECTION (SCR)

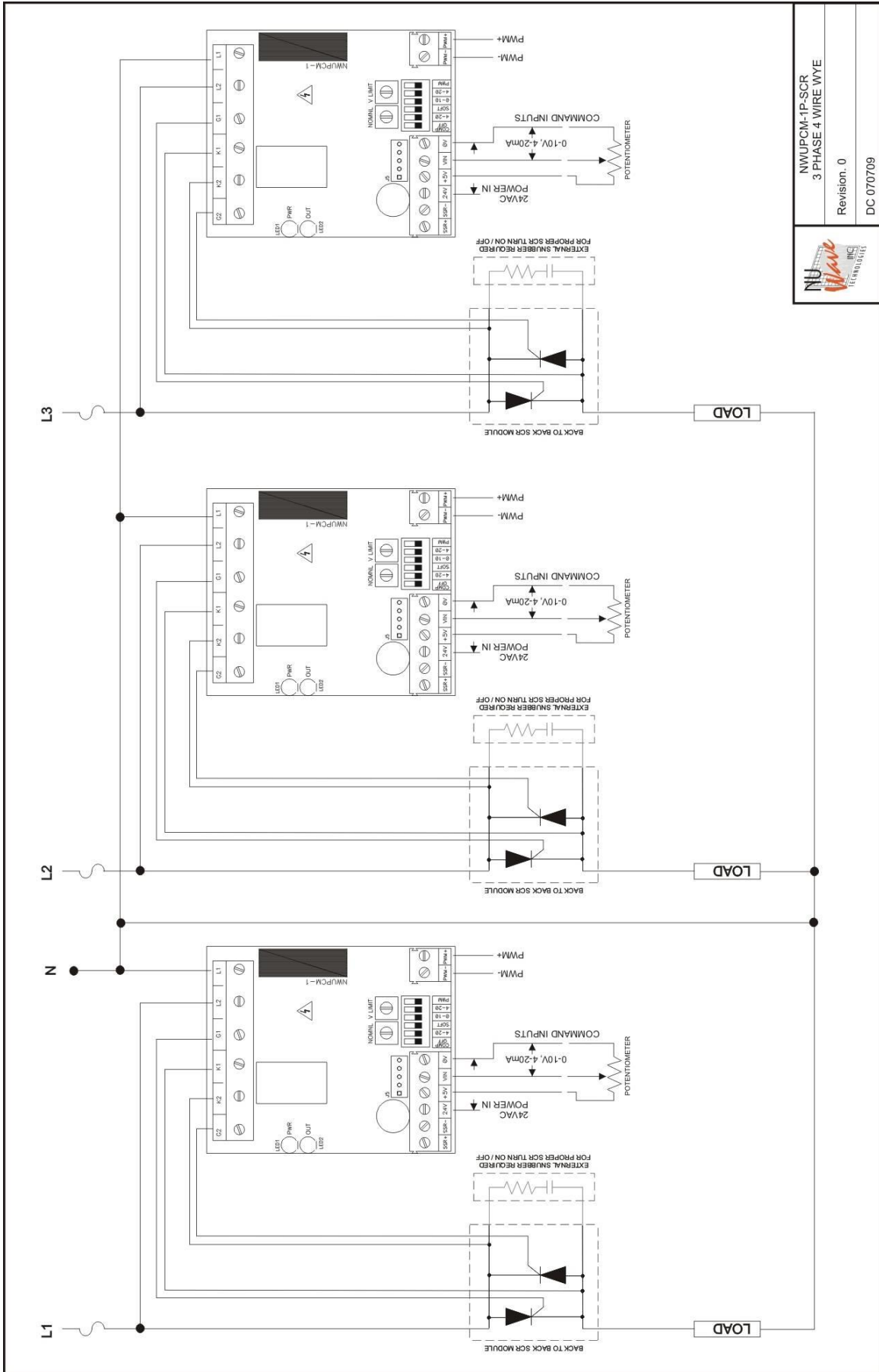

  
**NWUPCM-1P-SCR**  
**3 PHASE 4 WIRE WYE**  
 Revision: 0  
 DC 070709

# 11. WIRING DIAGRAM 3 PHASE INSIDE DELTA CONNECTION (SCR)

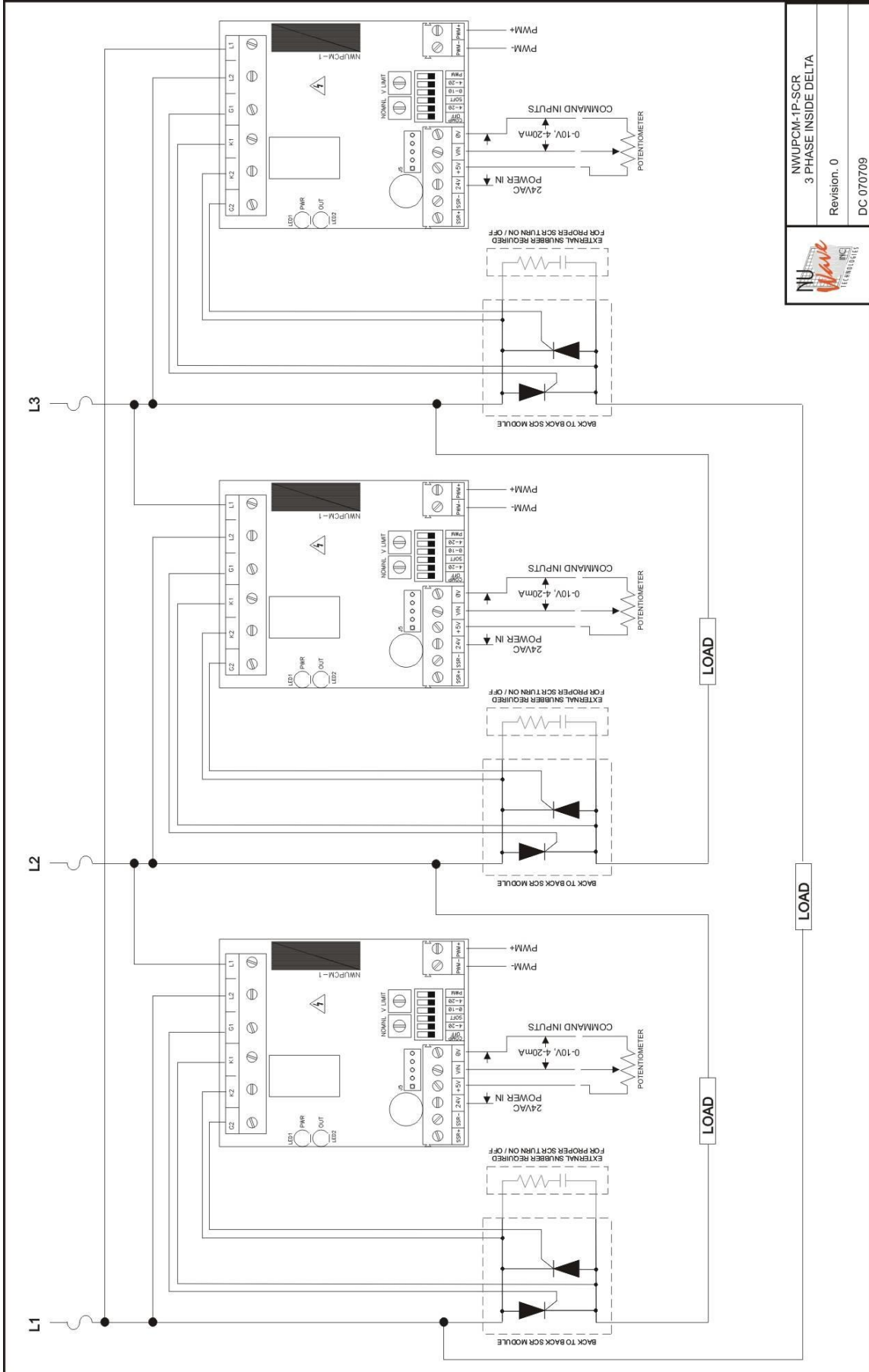

	NWUPCM-1P-SCR 3 PHASE INSIDE DELTA
	Revision: 0 DC 070709