



MIBRASA HMB AB 75, 110, 160

Mibrasa charcoal oven with cupboard below

TECHNICAL INFORMATION	HMB MINI	HMB 75	HMB 110	HMB 160
Diners*	35	75	110	160
Fire up time* (min)	20	25	30	35
Cooking temperature (°C)	250-350	250-350	250-350	250-350
Charcoal consumption* (kg/day)	7	13	18	20
Production* (kg/h)	25	70	100	120
Performance* (h)	8	9	10	10
Useful dimensions of grill (mm)	500 x 350	500 x 600	720 x 600	720 x 800
Equivalent power* (kW)	2	3,5	5	6
Exhaust rate (m ³ /h)	1500	2000	2400	2600

* Approximate data

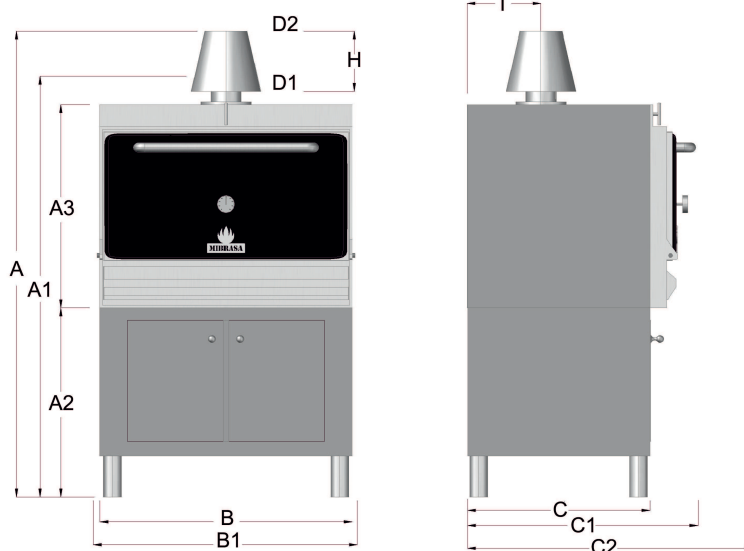

Model	A	A1	A2	A3	B	B1	C	C1	C2	H	I	D1	D2
HMB AB 75	1660	1480	740	650	700	730	640	820	1080	230	300	115	150
HMB AB 110	1710	1530	690	740	920	950	640	820	1170	230	300	115	150
HMB AB 160	1710	1530	690	740	920	950	840	1020	1360	230	350	115	150

INCLUDED ACCESSORIES

Grill
Oven tongs
Charcoal ember pocker
Ash shovel
Grill brush

OPTIONAL ACCESSORIES

Extra grill
Firebreak
Dissipating filter
Cookware
Steel wheels with brakes

OVEN'S DESCRIPTION

The air inlet is controlled by opening or closing the ash collector.



1. Firebreak
2. Regulator
3. Door handle
4. Grills
5. Thermometer
6. Interior grids
7. Door
8. Grease collector
9. Ash collector