

# MARINE SELF CONTAINED AIR CONDITIONING SYSTEM

## INSTALLATION MANUAL

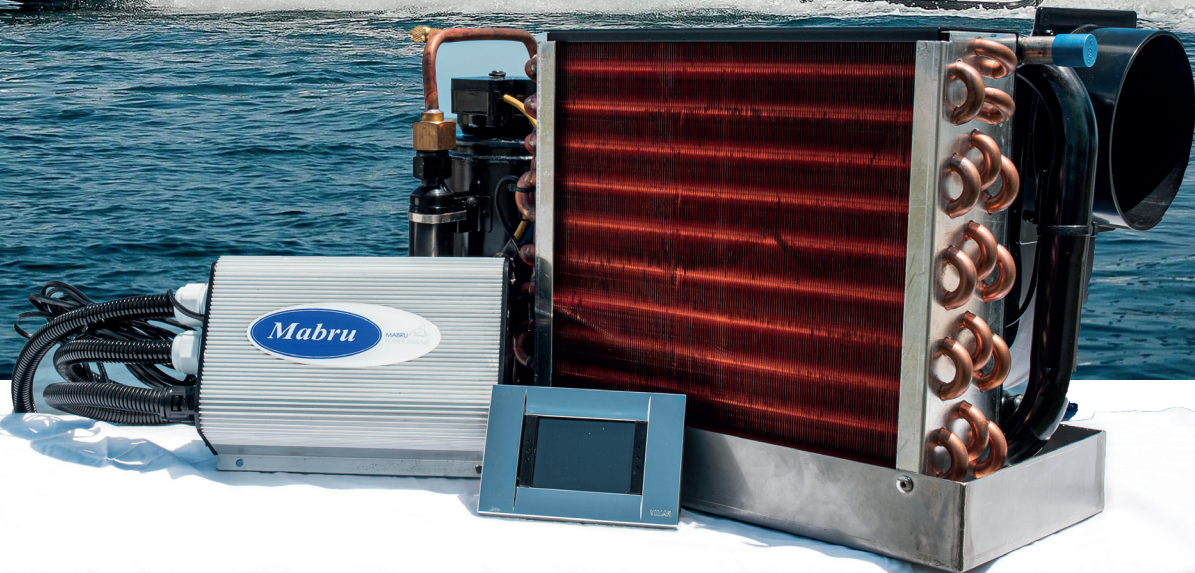



# TABLE OF CONTENTS

Introduction.....	03
Safety Precautions .....	04
Installation - Overview.....	06
Installation - Ducting .....	08
Installation - Seawater System .....	09
Installation - Checklist.....	14
Control Panel Operation .....	16
Wiring Diagram For 115/230v For Ac .....	20
Wiring Diagram For 12v Dc .....	21
Troubleshooting .....	22
Error Codes .....	24
Warranty & Returns .....	27



+1 888 818 2814

support@mabrumarine.com

# INTRODUCTION

Thank you very much for purchasing our SC series marine self-contained air conditioning unit!

This manual provides proper installation information on the Mabru air conditioning units (a/c units). Improper installation procedures can result in unsatisfactory performance and/or premature failure of these a/c units.

Before proceeding, please read this manual completely. If there are any statements or procedures in this manual that you do not understand, contact Mabru Power Systems for assistance.

**Phone 888 818 2814 (8 am to 4.30 pm US Eastern Time), or via email [support@mabrumarine.com](mailto:support@mabrumarine.com).**

Mabru a/c units are covered under the existing Mabru Limited Warranty. The Warranty is available on the last page of this manual. In the interest of product improvement, Mabru's specifications and design are subject to change without prior notice.

## FREQUENTLY ASKED QUESTIONS REGARDING THE SIZE AND CAPACITY SELECTION:

When sizing air conditioning systems for a boat, the area in question is not that important. The success to select the correct size and capacity in BTU should be determined not only by the area (cubic feet), but also the amount of windows, the quality of the window tint, the color of the hatches, the heat dissipation from the appliances on board, and so many other factors.

The question should not be, how many BTU do customers need to cool their cabin?

It is impossible in reality to answer that question before studying the insulation.

## POINTS TO HAVE IN MIND WHEN SELECTING YOUR AIR CONDITIONER:

- 1** When installing the unit in areas where the unit could return air from bilges or engine rooms and exterior, you must seal the compartment well, so return air must be from the area that you want to cool.
- 2** Discharge vents: Less vents the better. The air conditioner needs air circulation, this way dry air reacts on the skin evaporating the moisture and creating a cooling effect. In conclusion, a dry boat well ventilated is more important than a cool boat.
- 3** After over 35 years testing and creating some of the best marine units, we must conclude that the most important fact about marine air conditioning is the source of power and the efficiency. Nowadays, customers during hot days run their air conditioning on solar panels and at night on Lithium batteries.



+1 888 818 2814

[support@mabrumarine.com](mailto:support@mabrumarine.com)

# SAFETY - PRECAUTIONS

Never install your air conditioner in the bilge or engine room areas. Ensure that the selected location is sealed from direct access to bilge and/or engine room vapors. Do not terminate condensate drain line within three feet of any outlet of engine or generator exhaust systems, nor in a compartment housing an engine or generator, nor in a bilge, unless the drain is connected properly to a sealed condensate or shower sump pump.

**Safety Warning** - The ale unit should never be placed such that it can circulate carbon monoxide, fuel vapors or other noxious fumes into the boat's living spaces. Do not install or operate a self-contained unit in the engine room or near an internal combustion engine. Failure to follow these precautions could result in serious injury or death.

## THE FOLLOWING IS A SUMMARY OF THE LABELS ON THE UNIT:

**Danger** - Electrical shock hazard. Disconnect voltage at main panel or power source before opening any cover. Failure to comply may result in injury or death.

**Warning** - This component does not meet federal requirements for ignition protection. Do not install in spaces containing gasoline engines, tanks, LPG/CPG cylinders, regulators, valves or fuel line fittings. Failure to comply may result in injury or death.

**Warning** - To minimize the hazard of electrical shock and personal injury, this component must be effectively grounded. Refer to the installation guidelines for further information.

**Ignition Protection Warning** - Self-contained units do not meet federal requirements for ignition protection. Do not install in spaces containing gasoline engines, tanks, LPG/CPG cylinders, regulators, valves or fuel line fittings. Failure to comply may result in injury or death.

**Prior To Installation** - Read these instructions completely and then plan all connections which must be made to the ale unit including ducting, condensate drain line, seawater inlet and outlet hoses, electrical power connection, location of control, and seawater pump placement to ensure easy access for routing and future servicing.

**Blower Rotation** - Rotate the blower to the direction which allows the most direct airflow discharge through the ducting. Loosen the adjustment screw on the blower mount ring, rotate the blower to desired position, and then tighten adjustment screw.



**Placement of A/C Unit** - The A/C unit must be mounted to a low flat level surface, in the bottom of a locker, under a bunk or dinette seat, or in a similar location. Read the safety considerations above before mounting the unit.

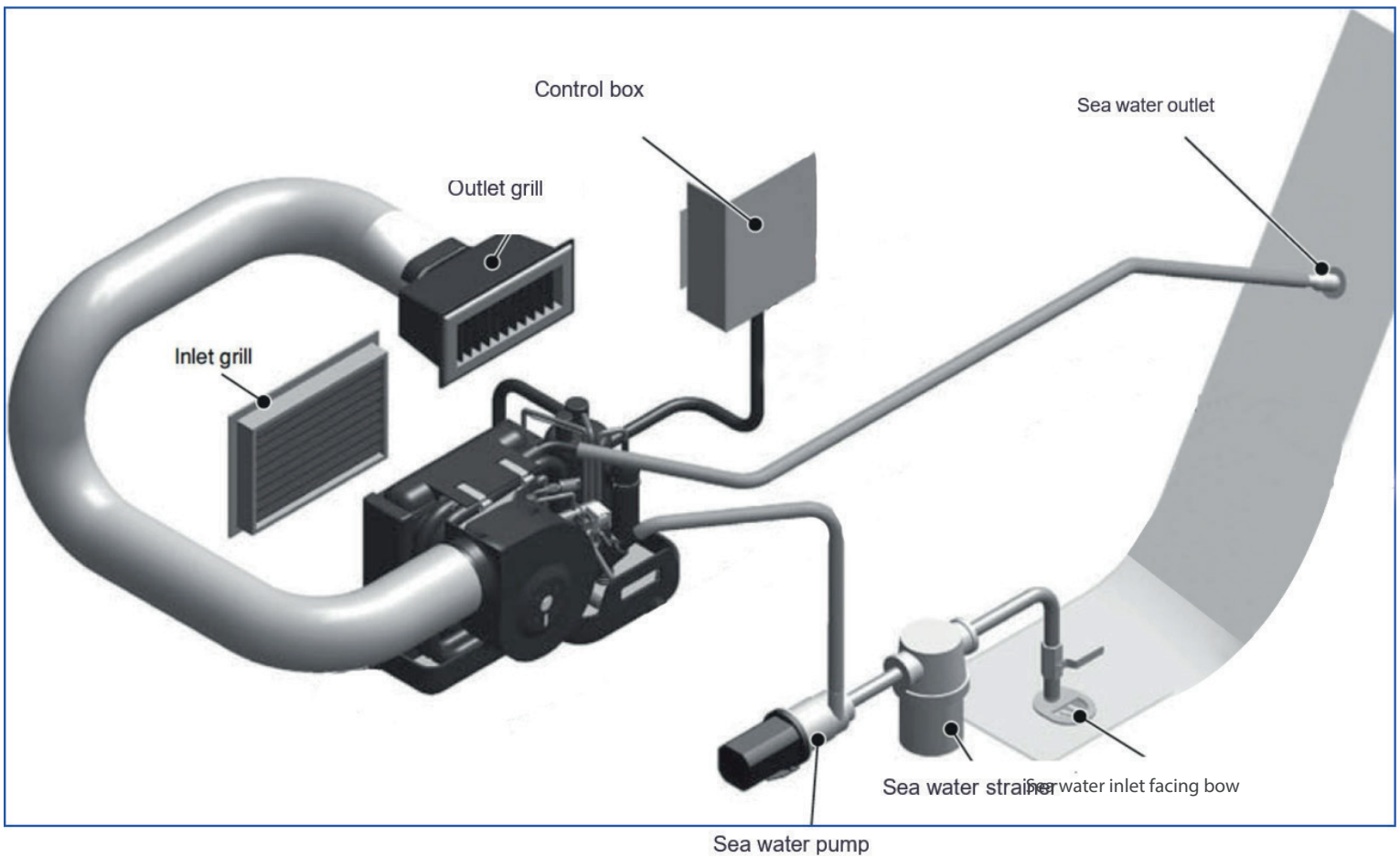

- A/C unit must be placed in a well-ventilated area. Never screw the unit directly into the hull.
- Do not install A/C unit in engine room or bilge compartment.
- Note: Air absorbed from A/C unit inflow into the room. Never place the unit in an engine compartment that is likely to produce poisonous gas.
- A/C unit is composed of some equipment that produces vibration or noise. Mount the unit in a horizontal floor with positive inclination towards drain to minimize sitting water in the drain pan.
- Install seawater inlet as low as possible.
- Scoop type thru-hull, ball valve, strainer, and sea water pump must be installed below the water line.
- Install inlet (return) grille as low as possible and outlet (discharge) grille as high as possible.
- Adjust the air outlet (blower position) by loosening the lock screw and securing the screw tightly once the air outlet is adjusted at the optimal location.

# INSTALLATION - OVERVIEW

Mount unit with condenser/evaporator coil directly behind return air grill or with at least 3" (76mm) of air circulation clearance if adjacent to a bulkhead or other obstruction. Compressor should be mounted away from return air grill if possible, to minimize sound level in cabin.

**Mounting Brackets** - The four mounting brackets provided should be placed around edge of drain pan as equally spaced as possible. Secure the unit to a flat level mounting surface. Customer is to supply screws or bolts.

- Route condensate drain hose to a sealed condensate or shower sump pump (see note below).
- Drain hose must be routed downward to allow water to flow via gravity downhill.

## Very Important!

Do not terminate condensate drain line within 3' (.91M) of any outlet of engine or generator exhaust systems, nor in a compartment housing an engine or generator, nor in a bilge, unless the drain is connected properly to a sealed condensate or shower sump pump. If drain line is not properly installed, then dangerous fumes may travel up drain line and contaminate living quarters.

## Items included in the box.

- Display cable
- Touch screen thermostat control
- Touch screen thermostat control Insulation tape
- Mounting clamps.
- (Mabru 12V Raw water pump included in the SC DC 12 Volts units Only)

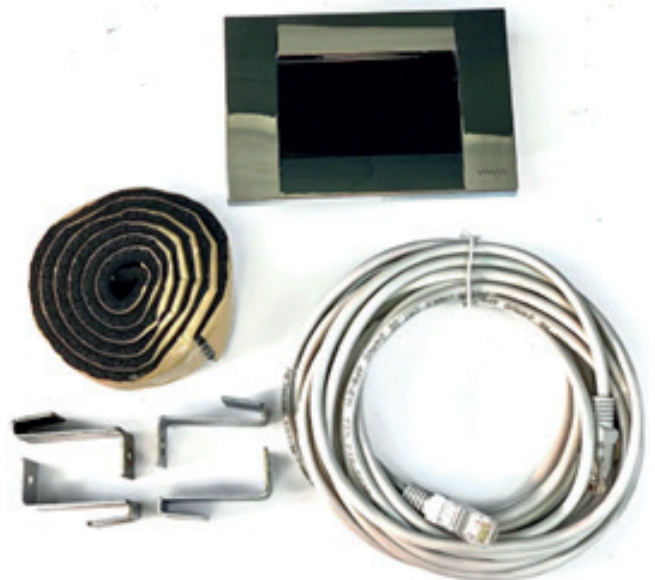

**Air Filters** - Air filters are necessary to remove air borne particulates from the cabin air and to keep the evaporator coil clean. One, and only one, air filter must be installed for each air conditioner unit. Install the air filter either on the A/C unit or in the return air (RA) grill. The A/C unit air filter mounts in the slots in front of the evaporator coil. Or, the return air filter attaches to the back of the RA grill. Clean the air filters regularly .

**Grills and Transition Boxes** - Install the supply air grill as high as possible in a location that will provide uniform air distribution throughout the cabin; grill louvers should be directed upward. The return air grill should be installed as low and close to the A/C unit as possible to ensure direct, uninterrupted airflow to the evaporator. The return air grill should have a minimum four inches 4" (101.6mm) of air circulation clearance in front of it, free from any furniture or other obstructions.

Under no circumstances should a supply air discharge be directed towards a return air grille, as this will cause the system to short cycle. Leave adequate space behind the air supply grill (s) for the transition box and ducts Connection.



+1 888 818 2814

support@mabrumarine.com

# INSTALLATION - DUCTING

Good airflow is critical for the performance of the entire system. The ducting should be run as straight, smooth and taut as possible, minimizing the number of 90° bends (two 90° bends can reduce airflow by 25%).

## THE FOLLOWING IS A SUMMARY OF PROPER DUCTING CONNECTIONS.

- Pull back the fiberglass insulation exposing the inner Vinyl duct hose.
- Slide the Vinyl duct hose around the mount ring until it bottoms out.
- Use Hose clamps or zip tie wraps to adjust duct hose into the transition ring. Make Sure duct are properly secured, so the hose will not slide off.
- Wrap duct tape around the ducting and ring joint to prevent any air leaks.
- Pull the insulation back up over the Vinyl duct to the ring and tape this joint.
- Remove excess ducting and use the same connection method at the supply (discharge) air grill.

## ALL DUCTING SHOULD:

- Be appropriately sized for each application.
- Run as smoothly and taut as possible.
- Have as few bends or loops as possible.
- Be securely fastened to prevent sagging during boat operation.
- Have all excess ducting lengths trimmed off.
- Not be flattened or kinked.
- Insulated when located in high heat load areas (hull side, mechanical compartments, etc.).
- Be properly protected against potential damage when routed through open areas.
- Do not route ducting through engine room or any area where it may be exposed to dangerous vapors or exhaust fumes.





# INSTALLATION - SEAWATER SYSTEM

Several guidelines should be followed during the installation of the seawater system. If the circulation pump is centrifugal and not self-priming, it must be mounted so that it is always at least one foot below the water line. Pump may be mounted horizontally or vertically, however the discharge must always be above the inlet. Pump head should be rotated toward the direction of water flow

Install the seawater scoop intake facing bow and as far below the water line and as close to the keel as possible in any application, but especially on a sailboat. The seawater scoop must remain in the water under all conditions or air will get into the pump. Turn air conditioner off in rough seas.

NOTE: The seawater scoop intake must face forward and not be shared with any other pump.

A seawater strainer is mandatory between the shut off valve (seacock) and the pump to protect the pump from any foreign matter. Failure to install a seawater strainer will void the pump and unit warranty.

The seawater system should be installed with an upward incline from the seawater scoop and seacock, through the strainer, to the inlet of the pump and then up to the inlet of the A/C unit's condenser coil. The discharge from the Mabru A/C unit should then run to the seawater outlet thru-hull fitting which should be located where it can be visually checked for water flow and as close as the waterline to reduce noise. All hose connections shall be secured by means of two double/reversed stainless steel hose clamps. Use marine sealant on all thread-ed connections



## The following is a summary of the seawater system installation:

- Install the seawater scoop thru-hull inlet as close to the keel and as far below the water line as possible, facing forward. Bed the scoop with a marine sealant designed for underwater use.
- Install a bronze, full flow seacock on the seawater scoop thru-hull inlet.
- Install a seawater strainer below the level of the pump with access to the filter.
- Mount the pump above or same level of the strainer and at least one foot below the waterline.
- Connect the seacock and strainer with an uphill run of reinforced marine-grade hose.
- Connect the discharge from the pump uphill to the bottom inlet of the A/C unit's condenser coil with 5/8" (15.9mm) reinforced marine-grade hose. Connect the discharge from the condenser coil to the overboard discharge thru-hull fitting with 5/8" (15.9mm) reinforced marine grade hose.
- Avoid loops, high spots, or the use of 90° elbows with seawater hose (each 90° elbow is equivalent to 2.5' (0.762M) of hose and a 90° elbow on the pump outlet is equivalent to 20' (61M) of hose.
- Double clamp all hose connections with two stainless steel clamps, reversing the clamps.
- Use marine sealant on all threaded connections.
- Connect all metallic parts in contact with seawater to the vessel's bonding system, including the speed scoop inlet, strainer, pump and the air conditioner, to reduce the possibility of any electrolysis problems.



# SEAWATER PUMP, COOLING WATER PIPE, DRAIN PIPING

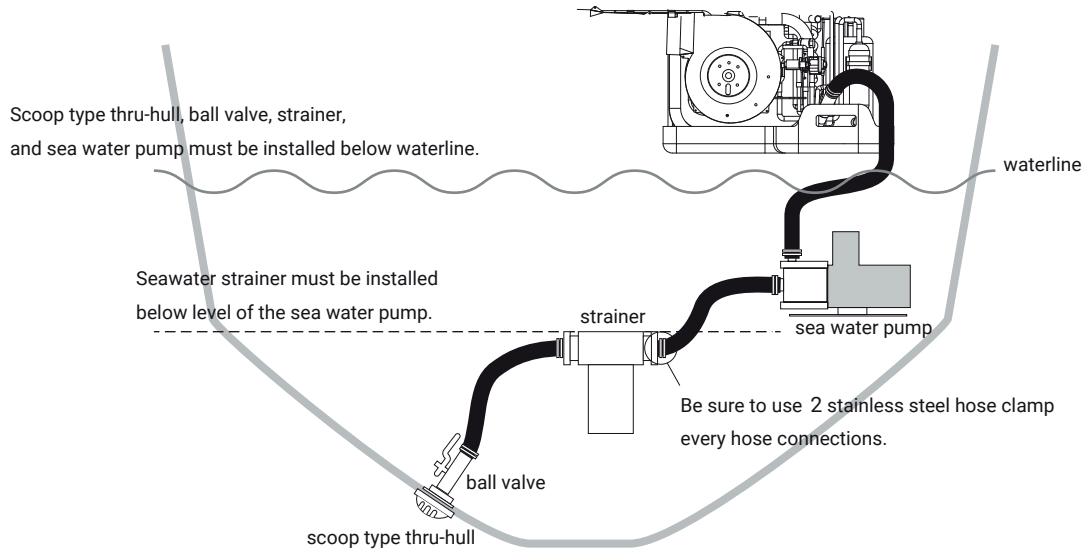

- Select a proper piping kit.
- Scoop-type thru-hull, ball valve, strainer, and sea water pump must be installed below the water line.
- Install a scoop-type thru-hull at seawater inlet to prevent drainage during operation.



Scoop-type thru-hull

- Install a ball valve in scoop-type thru-hull.
- Use marine grade sealant on all threaded connections



Ball valve

- Genuine seawater pump is a non-self priming type. Install the seawater pump, piping and strainer under the waterline. Contact us for self-priming seawater pump in case pump cannot be installed under the waterline.
- Seawater pump must be located at least 30cm below the waterline .
- If A/C unit is mounted at high place or the installation place is more than 10 meter away from seawater pump, use a high-flow pump.
- Connect 2 sets of stainless hose clamps to all hose connections and secured correctly.
- Place hoses as straight as possible and make sure air does not come into the hoses.



Seawater pump

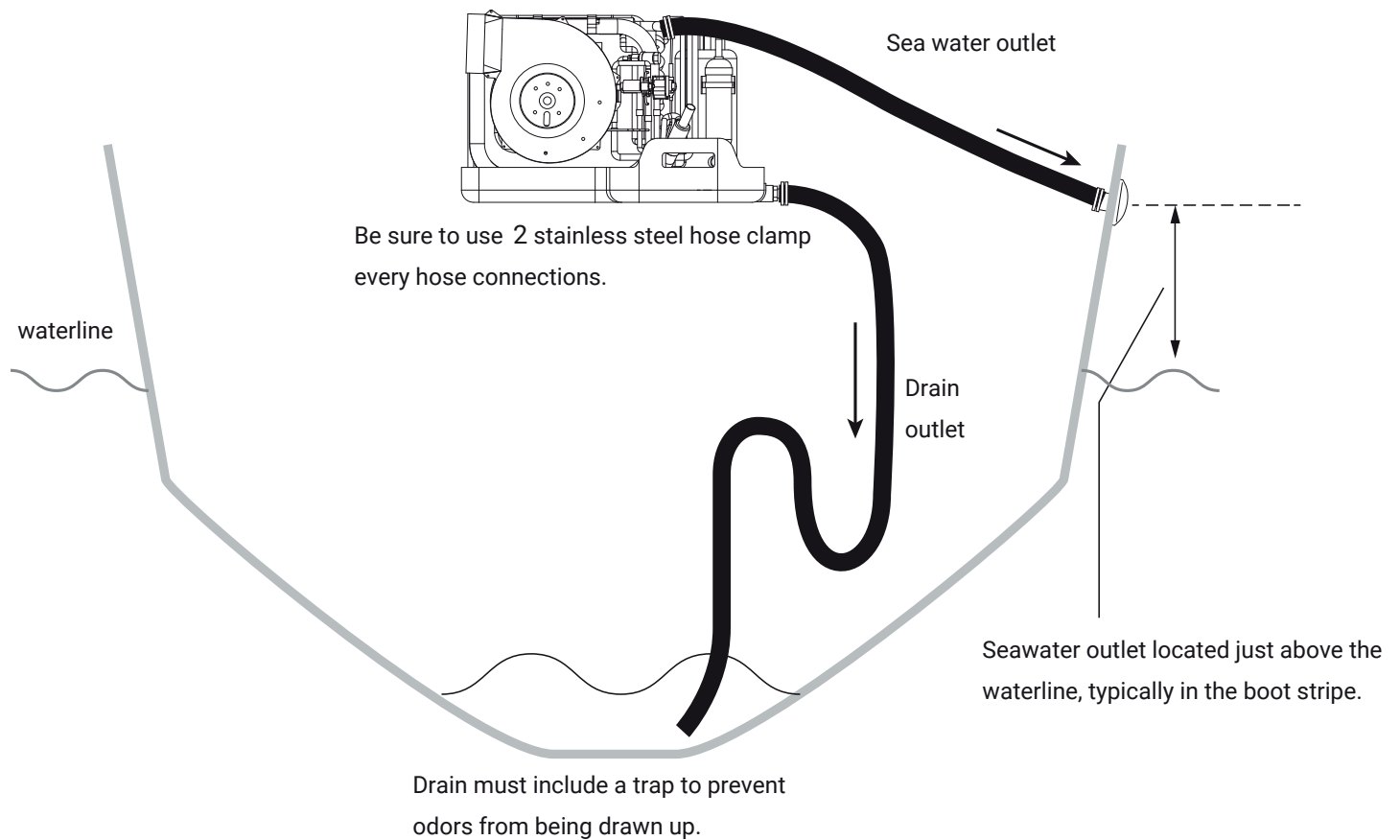

- Check the drain condensation water is discharged from drain pan smoothly.
- Drain outlet must be discharged to sealed sump or overboard, which must be installed in as far places as possible from engine or generator set outlet to avoid inflow of exhaust gas.
- Seawater outlet and drain outlet from A/C unit must be routed downhill.
- Check sea water through A/C unit are discharged smoothly.

**⚠ WARNING** Check all water connections for leaks and all hose clamps for looseness.

# FITTING

- Select a proper duct in accordance with A/C unit model.
- Use a well-insulated flexible duct to prevent the dew condensation water during cooling mode.
- Select a proper inlet grille and outlet grille
- Install the return grille as low places as possible and discharge grill as high as possible.

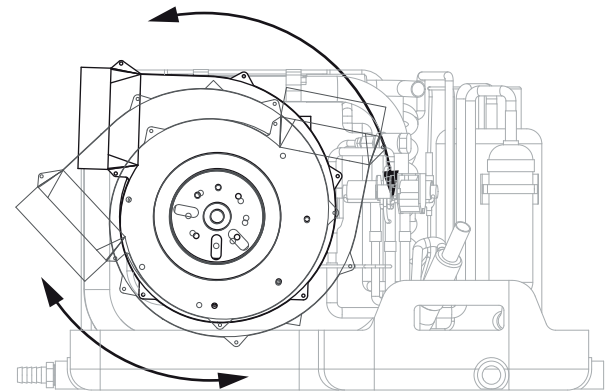
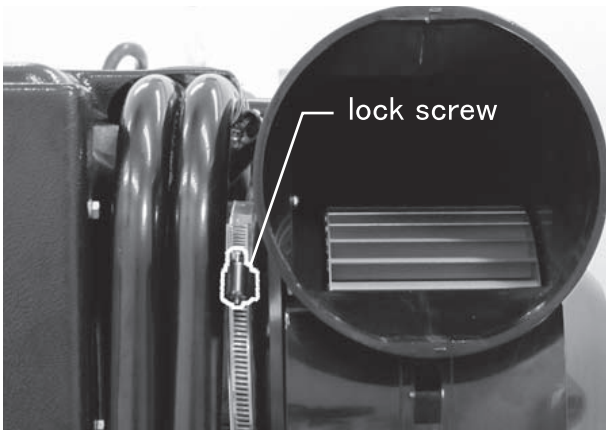
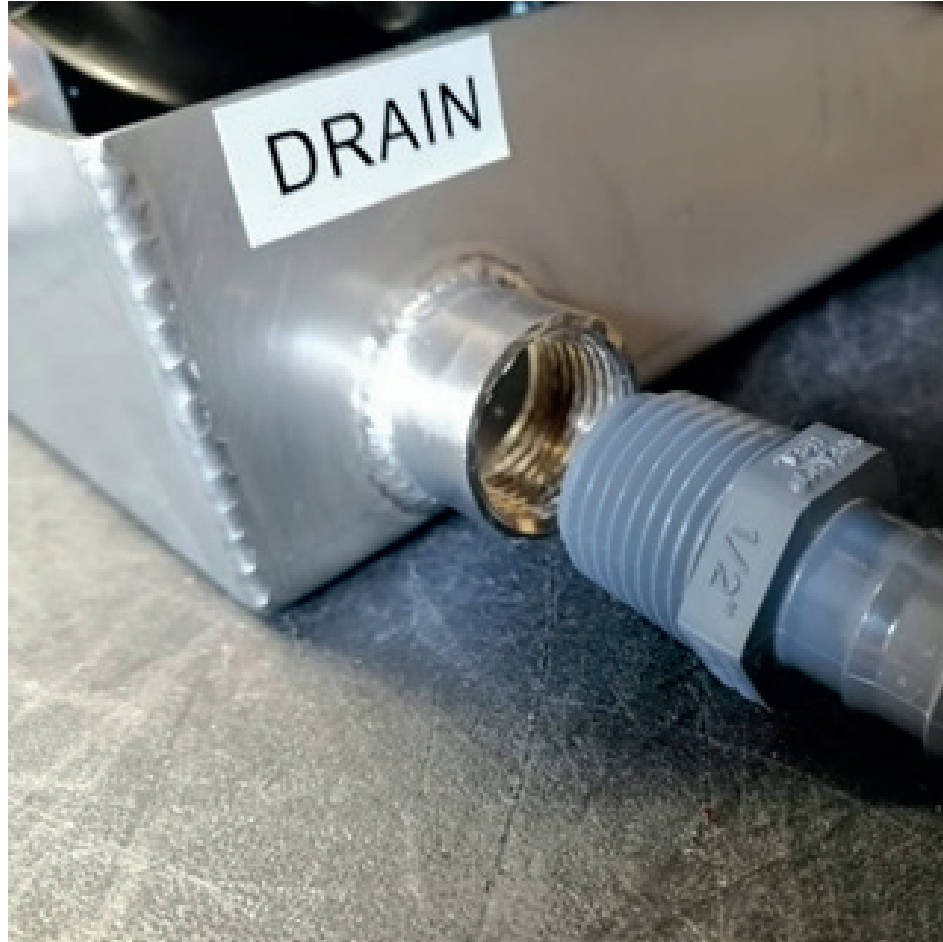

Adjust the air outlet by loosening the lock screw and secure the screw tightly once the air outlet is adjusted at the optimal location.

# INSTALLATION - CHECKLIST

## SEAWATER COOLING SYSTEM

- Speed scoop located as far below the water line and as close to the keel as possible
- Shut off valve (seacock) and speed scoop properly sealed and tight
- Seawater pump is at least one foot below water line and securely mounted
- Strainer mounted below pump with access to filter
- Double/reversed stainless steel hose clamps on all hose connections
- Teflon tape goes on all threaded connections
- Hose runs uphill from speed scoop and seacock to strainer, pump and MABRU AC unit, then downhill (if possible) from MABRU AC unit to overboard discharge
- Water flowing freely from overboard discharge while pump is running
- Pump relay panel, if used, must have its own circuit breaker sized for the pump (20 Amp max)
- All metal fittings should be bonded

## MOUNTING

- Not in engine room or bilge areas, must be sealed away from exhaust or fumes
- Proper spacing allowed around unit
- Attached to solid level platform with hold down clips provided
- Condensate drain routed aft and downhill to a sealed sump (not bilge)
- Blower rotated toward supply air grille

## GRILLES AND DUCTING

- Supply air grille mounted as high as possible
- Return air grille mounted as low and as close to the A/C unit as possible
- Return air grille mounted away from bilge vapors or exhaust fumes
- Ducting is pulled taut, straight, smooth and properly connected with no excess



## Electrical

- All butt connections on pumps wire tightly, crimped and heat shrunk
- AC power source installed and grounded/bonded in accordance with ABYC standards
- Circuit breakers sized according to specifications on the data plate label
- Digital display Cable is connected at both ends
- Digital display Ethernet Cable is connected at both ends
- Pump Relay Panel (if used) has a dedicated circuit breaker sized for the pump, but not to exceed 20 amps maximum.

## Quick Start Operations Checklist

- Ensure seawater intake ball valve (seacock) is open.
- Turn on the A/C circuit breaker. If the seawater pump has its own circuit breaker, turn that on.
- Turn the system on.
- Set the desired cabin temperature (set point).
- Check for a steady solid stream of water from the overboard discharge.
- Verify that there is steady airflow out of the supply (discharge) air grille.
- If the unit does not appear to be operating properly, refer to troubleshooting guidelines.



# CONTROL PANEL OPERATION

## To Switch degree units between F° and C°:

- **For the new Color Touch screens:** Navigate on the menu and select temperature format. Then select between the unit options.
- **For Black and White touch screens:** Keep and hold Up and Down Buttons ( ↑ / ↓ ) for about 5 seconds until you hear the beep. It will change between F° and C°. (only black and white screen)

## For Blower (Fan) setting On or OFF:

**NOTE:** By default you have the Mabru fan to be always on and slows down when the compressor shuts off keeping the blower always running recirculating the air flow.

- **Some customers prefer to switch the blower off when the compressor turns off once the desired room temperature setting is reached. To set the air conditioner as silent mode, follow the steps below:**

- 1 Turn on the unit.
- 2 Hold down the FAN button for few seconds until hear the beep. FAN mode setting will change. Do the same procedure to return to the previous setting mode.

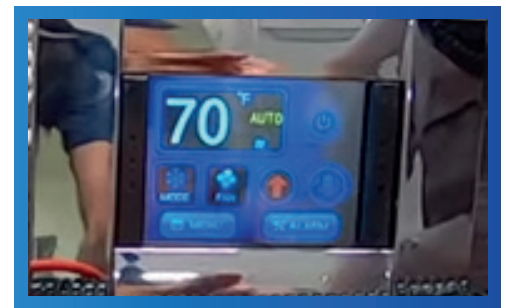
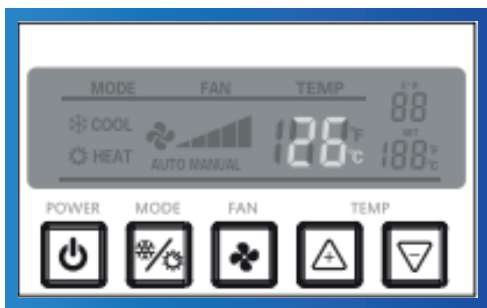

**NOTE:** For the color touch screen follow the menu options. When the control fan is "off", the fan option is set as default, keeping the blower circulating air. If you select the "on" you will activate the option to turn off the blower when the compressor is off.



## Control panel Product features

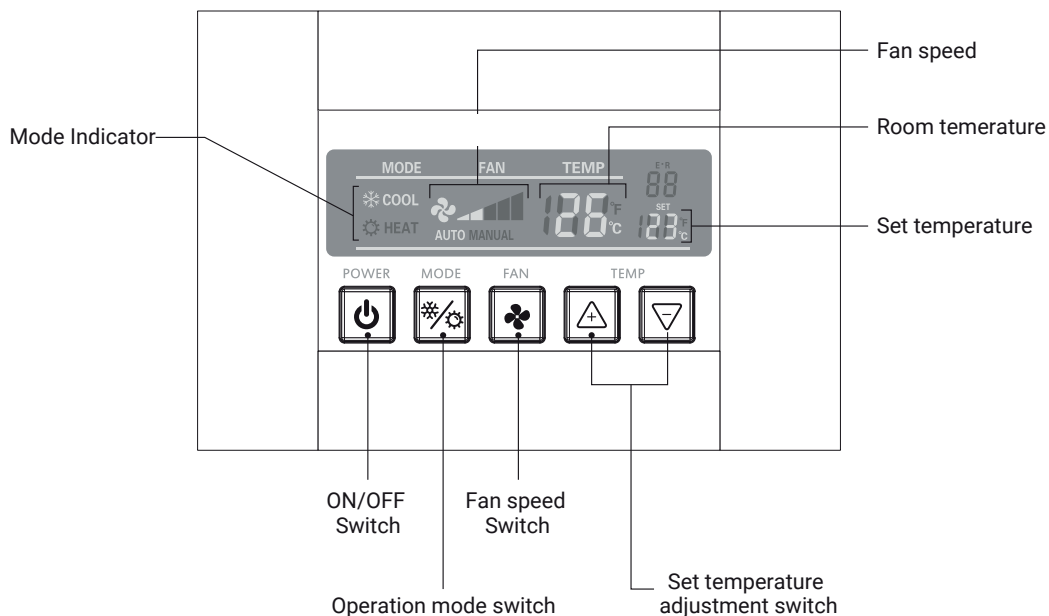

## Main display

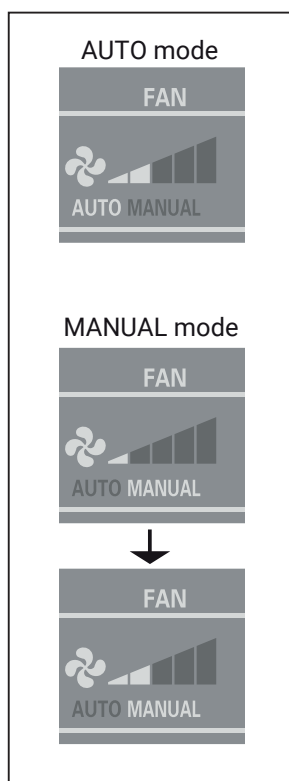

Fan speed

AUTO

Fan speed is adjusted automatically and the meter is displayed in the same way.

MANUAL

Press the FAN button to adjust fan speed.

## Room temperature & Set temperature

The displayed digit under "TEMP" shows room temperature.

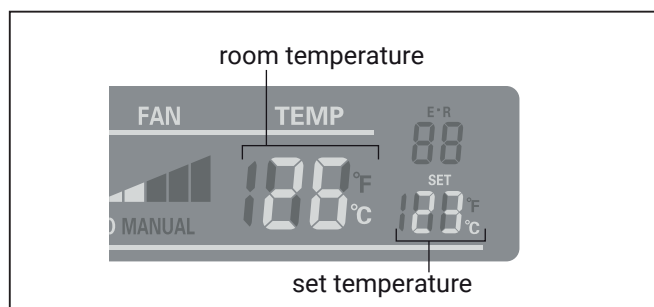

The displayed digit under "SET" shows set temperature, which can be adjusted by pressing TEMP button.

# Control panel operation

## 1. Stand-by mode

When power supply is turned on, preset room temperature and operation mode will be indicated on the panel.

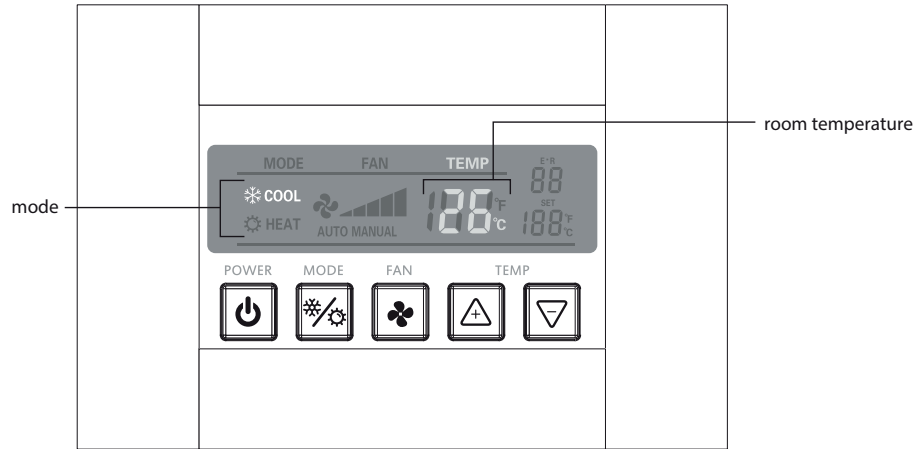

## 2. Operation

When pushing the power button, the operation light will be lit with the previous preset mode (COOL or HEAT) and the A/C unit will start an operation.

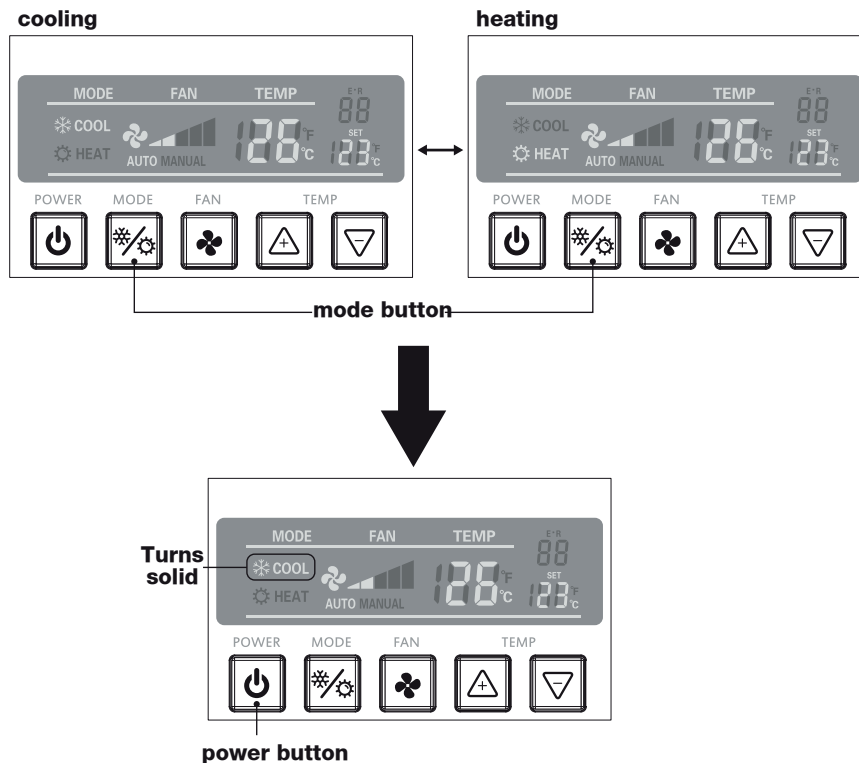

### 3-1. Set Temperature

Press the TEMP button to select desired temperature.

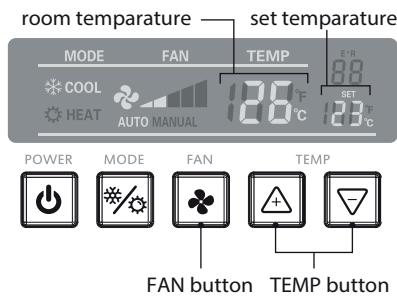

The operation mode “AUTO” will be lit when auto operating while “MANUAL” when manual operating.

### 3-2. Fan speed

Press the FAN button to adjust fan speed: in the order of Auto, 1 to 5 stages. When selecting AUTO, fan speed will be adjusted automatically in accordance with the room temperature and the display will be also adjusted accordingly.



The “AUTO” display lights and fan speed will be adjusted according to the room temperature and set temperature.

The “MANUAL” digit will be lit when selecting manual mode. Press the FAN button to adjust desired fan speed: in the order of AUTO, 1 to 5 stages.

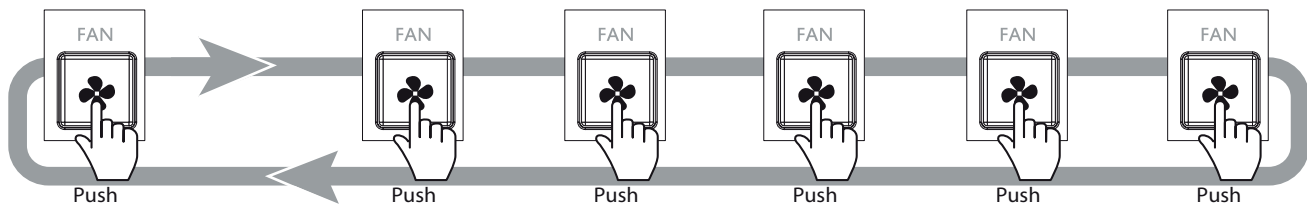

Press the FAN button to select the operation mode and fan speed.

### 4. Turning the system off

Press the POWER button to stop the A/C unit during its operation. The operation mode will be switched to “stand-by” mode.

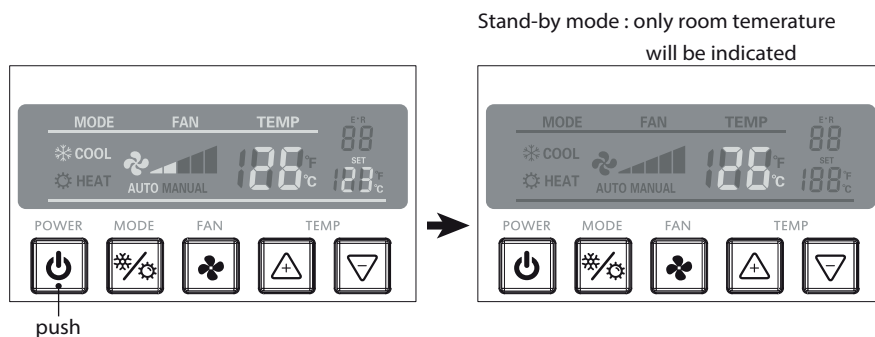

**CAUTION** Sea water pump will be activated after AC unit starts and compressor will be activated 30 seconds after the AC unit starts. Fan will not be activated until gas temperature reaches the fixed value.

**CAUTION** Compressor will stop once it reaches set temperature, but does not re-start for 3 minutes after the stop.

# WIRING DIAGRAM FOR 115/230V FOR AC

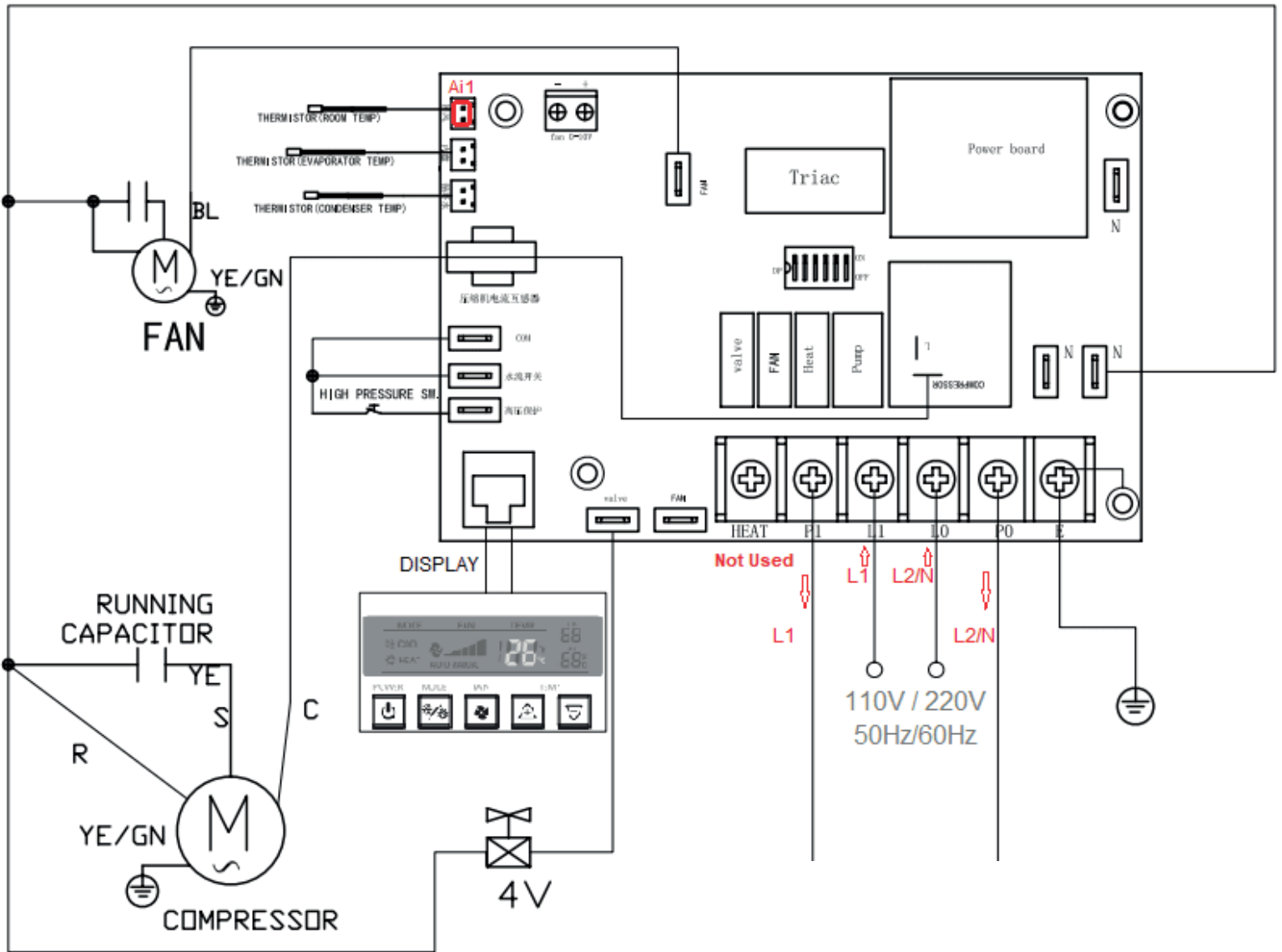

# WIRING DIAGRAM FOR 12V DC

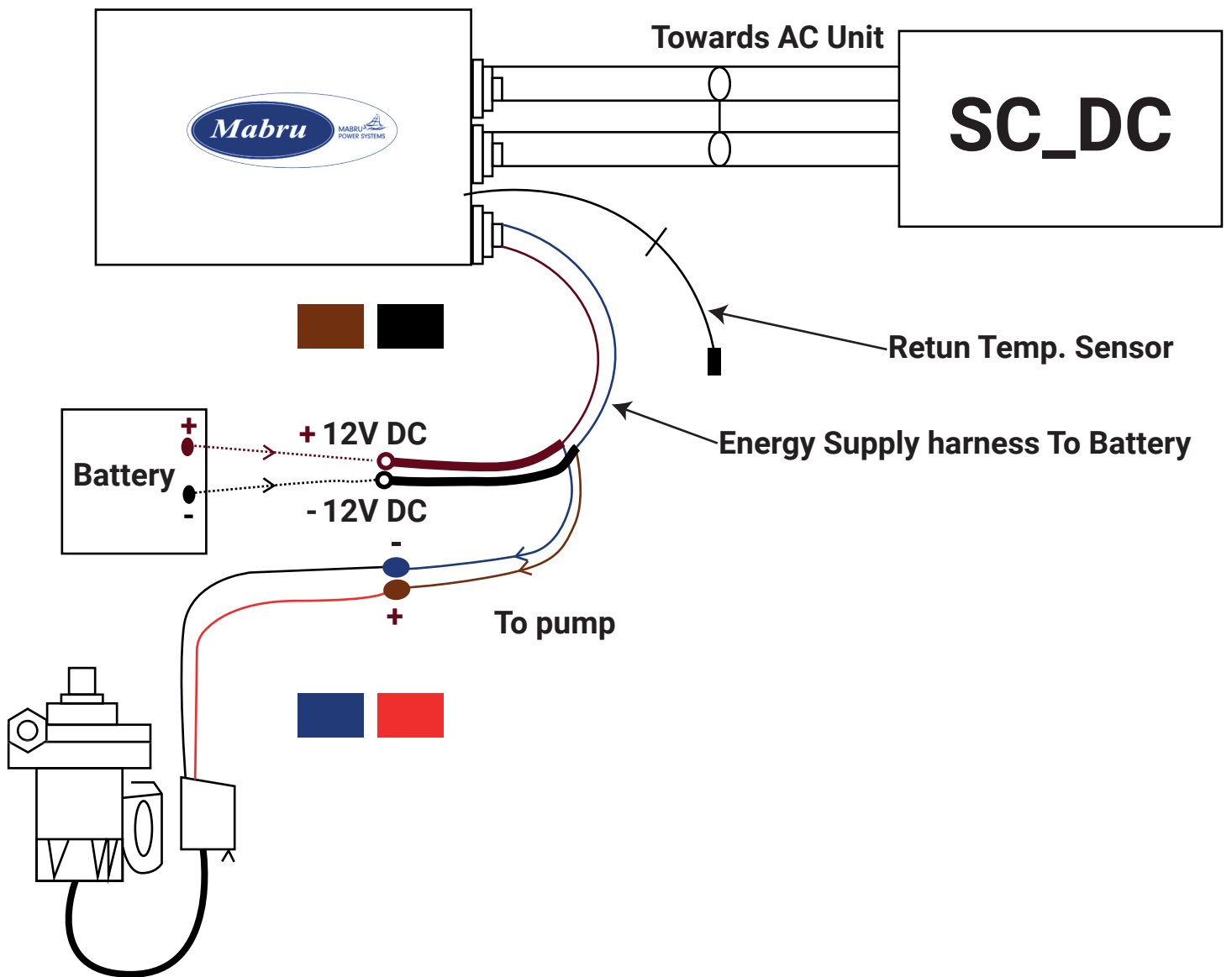

# TROUBLESHOOTING

## WHEN MARINE AIR CONDITIONER DOES NOT START.

Probable Cause: A/C unit circuit breaker is off.

Recommended Action: Turn on the circuit breaker.

Probable Cause: Power switch of control panel is off.

Recommended Action: Turn on the power switch of control panel.

Probable Cause: Compressor protection is activated.

Recommended Action: Turn off the power and wait 3 minutes, then restart.

Probable Cause: Wrong wiring at control box terminal.

Recommended Action: Connect the wires correctly.

Probable Cause: Inadequate voltage.

Recommended Action: Check the power source voltage with voltmeter and A/C unit wiring.

## WHEN COMPRESSOR DOES NOT WORK.

Probable Cause: Compressor circuit breaker is off

Recommended Action: Turn on the circuit breaker.

Probable Cause: Compressor protection is activated.

Recommended Action: Turn off the power and wait 3 minutes, then restart.



+1 888 818 2814

support@mabrumarine.com

# TROUBLESHOOTING

Probable Cause: Seawater flow is obstructed.

Recommended Action: Check the seawater strainer and scoop type thru-hull and clean them if necessary.  
Check if seawater is discharged smoothly.

Probable Cause: Air entrainment to seawater pump.

Recommended Action: Purge the air completely from the pump.

Probable Cause: Seawater temperature is too high for cooling or too low for heating.

Recommended Action: Reset set temperature lower or higher.

Probable Cause: Air entrainment to seawater pump.

Recommended Action: Purge air completely from the system.

Probable Cause: Loss of refrigerant.

Recommended Action: Check the refrigerant leakage. Consult your local distributor/dealer or Mabru Marine.

## LOW AIRFLOW

Probable Cause: Seawater temperature is too high for cooling or too low for heating.

Recommended Action: Reset set temperature lower or higher.

Probable Cause: Freezing of a coil.

Recommended Action: Shut down A/C unit and check the seawater temperature.



+1 888 818 2814

support@mabrumarine.com

# ERROR CODES

CODE ERROR	DEFINITION OF ERROR	ISSUE	POSSIBLE CAUSES	POSSIBLE CORRECTION
1	Room temperature sensor error	Compressor stops	Failure of room temperature sensor	"Check for operation panel and RJ45 cable Replace them as necessary"
2	Radiator temperature sensor error	Radiator temperature sensor is broken or compressor	Failure or wire breakage of radiator temperature sensor	"Check for the radiator temperature sensor and replace as necessary Connect the AI2 connector if it comes off"
3	Seawater temperature sensor error	Seawater temperature sensor is broken or compressor stops	Failure or wire breakage of seawater temperature sensor	"Check for the radiator temperature sensor and replace as necessary Connect the AI3 connector if it comes off"
4	Radiator high temperature error	Compressor stops due to high temperature of radiator when in heating mode	"Loss of seawater or clogged seawater strainer Seawater pump is broken Air does not circulate through the unit Clogged inlet grille Fan does not rotate normally"	"Check for seawater outlet and clean the seawater passage and seawater strainer as necessary Bleed the air if seawater pump absorbed the air Clean inlet grille and filter if air volume is not enough Check for duct piping"
5	Gas leak error	Compressor stops	Breakage of gas piping	Consult an authorized distributor or dealer



# ERROR CODES

CODE ERROR	DEFINITION OF ERROR	ISSUE	POSSIBLE CAUSES	POSSIBLE CORRECTION
6	ERROR 6 ON 12VOLTS	LED Flashing sequence	<p>1 Current overload protection (2 short 2 long)</p> <p>2 Undervoltage protection (3 short 2 long)</p> <p>3 Voltage Overload protection (4 short 2 long)</p> <p>4 Startup failure (5 short 2 long)</p> <p>5 Compressor low speed protection (2 short 3 long)</p> <p>6 Overload protection (3 short 3 long)</p> <p>7 Internal temperature protection (4 short 3 long)</p>	Restart unit / restart the circuit breaker
8	High pressure gas error	Compressor stops	<p>"Loss of seawater or clogged seawater strainer</p> <p>Seawater pump is broken</p> <p>Air does not circulate through the unit</p> <p>Clogged inlet grille</p> <p>Fan does not rotate normally"</p>	<p>"Check for seawater outlet and clean the seawater passage and seawater strainer as necessary</p> <p>Bleed the air if seawater pump absorbed the air</p> <p>Clean inlet grille and filter if air volume is not enough</p> <p>Check for duct piping</p> <p>Descale"</p>
9	Radiator freezing error	Compressor stops	<p>"Air does not circulate through the unit</p> <p>Clogged inlet grille</p> <p>Fan does not rotate normally"</p>	<p>"Clean inlet grille and filter if air volume is not enough</p> <p>Check for duct piping</p> <p>Change direction of the supply grille if air gets colder"</p>

# ERROR CODES

CODE ERROR	DEFINITION OF ERROR	ISSUE	POSSIBLE CAUSES	POSSIBLE CORRECTION
10	Seawater temperature error	Compressor stops Pump stops	"Seawater temperature too high/low (below 0* at heating mode, below 15* at cooling mode)  Operation mode is wrong - cooling mode in a cold climate or heating mode in a warm climate"	"Check for seawater outlet  Check if selected ""MODE"" is correct"
11	Connection is incorrect		DI1 & DI3 connectors are switched	While unit is off, check for connectors are in the correct labeled spot
12	Compressor overcurrent error	Compressor stops	"Loss of seawater or clogged seawater strainer  Seawater pump is broken  Voltage drop  Compressor trouble"	"Check for seawater outlet and clean the seawater passage and seawater strainer as necessary  Bleed the air from seawater pump if the pump absorbed the air  Check if power supply voltage is normal"
15	Communication error between circuit breaker and operation panel	Unit stops	Touch Screen contro, RJ45 Ethernet cable or circuit board is broken due to humidity	Check the Touch Screen control panel, RJ45 Ethernet cable, and /or circuit board if was affected by moisture.

# WARRANTY & RETURNS

You may return most new, unopened items within 30 days of delivery for a full refund. We'll also pay the return shipping costs if the return is a result of our error (you received an incorrect or defective item, etc.).

You should expect to receive your refund within four weeks of giving your package to the return shipper. However, in many cases you will receive a refund more quickly. This time period includes the transit time for us to receive your return from the shipper (5 to 10 business days), the time it takes us to process your return once we receive it (3 to 5 business days), and the time it takes your bank to process our refund request (5 to 10 business days).

If you need to return an item, simply login to your account, view the order using the 'Complete Orders' link under the My Account menu and click the Return Item(s) button. We'll notify you via e-mail of your refund once we've received and processed the returned item.

## OWNER'S LIMITED WARRANTY POLICY

This Warranty is made to a purchaser ("owner" or "you"), who acquires the Mabru Power Systems, Inc. ("Mabru")-manufactured product or component (the "Mabru product") for his or her own use. 1. WHAT'S COVERED What does the Limited Warranty cover? The Mabru products under this limited warranty are to be free from defects in material and workmanship at the time of sale and under normal use. If Mabru determines to its satisfaction that a Mabru product contains such a defect during the applicable Warranty Periods set out within Section 4 COVERAGE PERIOD AND TABLE OF WARRANTY PERIODS, then Mabru shall, at Mabru's sole discretion, repair or replace the Mabru product, or refund the original purchase price. Note: Where labor is included for a particular Mabru product covered under this Limited Warranty (See Section 4 COVERAGE PERIOD AND TABLE OF WARRANTY PERIODS), Mabru is not responsible for additional labor charges associated with the removal, reinstallation, or replacement of any equipment or furnishings beyond the particular covered Mabru product. This Mabru Limited Warranty allows up to 1.0 (One) hour for the Servicing Dealer's travel time. Any additional travel time is the owner's sole responsibility. This Limited Warranty is made in lieu of all other express warranties, obligations, or liabilities on the part of Mabru. In those instances, in which Mabru chooses to make a cash refund of the original purchase price, such refund shall affect the cancellation of the contract of sale without reservation of rights on the part of the owner. Such refund shall constitute full and final satisfaction of all claims which the owner has or may have against Mabru resulting from any actual or alleged breach of warranty, either express or implied. IN NO EVENT SHALL MABRU BE LIABLE FOR EITHER INCIDENTAL OR CONSEQUENTIAL DAMAGES. THIS INCLUDES ANY DAMAGE TO ANOTHER PRODUCT OR PRODUCTS RESULTING FROM SUCH A DEFECT.



+1 888 818 2814

support@mabrumarine.com

SOME STATES DO NOT ALLOW THE EXCLUSION OR LIMITATION OF INCIDENTAL OR CONSEQUENTIAL DAMAGES, SO THE ABOVE LIMITATIONS MAY NOT APPLY TO YOU. ANY IMPLIED WARRANTY, INCLUDING THE IMPLIED WARRANTY OF MERCHANTABILITY AND FITNESS FOR ANY PURPOSE, IS LIMITED TO THE DURATION OF THIS LIMITED WARRANTY. SOME STATES DO NOT ALLOW LIMITATIONS ON HOW LONG AN IMPLIED WARRANTY LASTS, SO THE ABOVE LIMITATIONS MAY NOT APPLY TO YOU. THIS WARRANTY GIVES SPECIFIC LEGAL RIGHTS, YOU MAY ALSO HAVE OTHER RIGHTS WHICH VARY FROM STATE TO STATE. Mabru reserves the right to improve or change the design of any Mabru product without notice and with no obligation to make corresponding changes in Mabru products previously manufactured.

**2. WHAT'S NOT COVERED** What does this Limited Warranty not cover? This Warranty Shall Not Apply to: 1. Failures resulting from improper or faulty installation, installation that does not comply with Mabru's instructions or otherwise, installation that does not comply with any American Boat and Yacht Council ("ABYC") standards, and any damage resulting from such. 2. Failures resulting from abuse, misuse, accident, fire, submergence, improper application or use contrary to instructions. 3. Failures resulting from lack of regular preventative maintenance as outlined within the Operator's Manual specific to your Mabru product. 4. Any Mabru product, which has been altered so as to impair its original characteristics. 5. Items not manufactured by Mabru. 6. Mabru products used by or applied by the owner as an integral part of products not manufactured by Mabru. 7. Additional labor charges associated with the removal, reinstallation, or replacement of any equipment or furnishings beyond the particular covered Mabru product. The original installer or OEM is responsible for the accessibility of the Mabru product. 8. The Servicing Dealer's travel costs in excess of 1.0 (one) hour. 9. Pumps with cracked heads or pumps that have been run dry, are water damaged or have blown freeze plugs. 10. Gauge instrument calibration. 11. Exterior corrosion. 12. Water damage, including specifically to the following components: blowers, logic boards and displays heads. 13. Incorrect programming of displays. 14. Dirty Condensers and/or Evaporators. 15. Failures due to improper winterization. 16. Mabru product damage as a result of improper return packaging or other freight damage. 17. Replacement of refrigerant with substitute without Mabru preauthorization. 18. Environmental and/or Recovery Fees. 19. Welding and Nitrogen Fees. Installation and application of Mabru products are not warranted by Mabru unless installation was performed in house because Mabru has no control or authority over the selection, location, application, or installation of Mabru products.

**3. GETTING SERVICE** How do you get service? Please read the following Warranty Procedure: In order to obtain the benefits of this Warranty, the owner needs to first submit the Mabru Warranty Claim form, which may be obtained by requesting from our claims department by emailing [support@mabrumarine.com](mailto:support@mabrumarine.com). Upon approval of the claim, the owner has the following three options during the applicable Warranty Coverage Period: 1) Preferred option: Have a Mabru authorized Servicing Dealer perform the work needed. The customer needs to contact the Mabru Customer Service Department for a recommendation as to the closest authorized Servicing Dealer.



+1 888 818 2814

[support@mabrumarine.com](mailto:support@mabrumarine.com)

If the customer already knows of an authorized Servicing Dealer, the Servicing Dealer should be contacted directly. 2) Second option: If the customer contacts the Mabru Customer Service Department for an authorized Servicing Dealer and there are none in the particular area, Mabru may authorize the use of a local Servicing Dealer, in which event Mabru will work with the local Servicing Dealer to assist in any way possible. 3) Third option: The customer may send the Mabru product back to the factory to have the repair work done. Mabru will make every effort to return the equipment to the customer within a three-week time period. If the claim represents a valid warranty issue, Mabru will pay the freight both ways. Mabru prefers option one first, option two second, and option three only if option one or two are not available. Refer to the Mabru Customer Service Department section below for contact information. Any Mabru product returned in the manner described above will be examined by the Servicing Dealer and/ or by Mabru. If it is found that the returned item was defective in material and workmanship at the time of sale, the Servicing Dealer will contact Mabru for Warranty coverage. Mabru shall, at Mabru's sole option, repair or replace the Mabru product, or refund the original purchase price. If Mabru determines that repairs to the Mabru product are to be made, then only authorized Mabru parts will be used. Mabru does not authorize any person or company to create any Warranty obligations or liability on its behalf. No action to enforce this Warranty shall be commenced later than ninety (90) days after the expiration of the applicable Warranty Coverage Period as set out within Section 4 COVERAGE PERIOD AND TABLE OF WARRANTY PERIODS. Claims must be submitted in writing to the Mabru Marine Division Warranty Department.

**4. COVERAGE PERIOD AND TABLE OF WARRANTY PERIODS** What is the Warranty Coverage Period? The Mabru product's Warranty Coverage Period begins from the date of possession of the boat by the original owner (if OEM installed) or from the date of installation (if the Mabru product is installed by a dealer). However, as outlined in the below TABLE OF WARRANTY PERIODS, the Warranty Coverage Period will not exceed the specified time period from date of manufacture. The Warranty is transferable and will carry any remaining warranty Coverage Period based on the above. The Warranty Coverage Period does not restart following any repair or replacement of the Mabru product. All Mabru products bear a data plate, which includes the Mabru product model and serial numbers. The serial number is date coded. To determine whether any Mabru product is covered under this Warranty, proceed as follows: 1. Determine the manufacture date of the Mabru product from the serial number found on the data plate. If you are not familiar with the date code, write or call the Mabru Customer Service Department to obtain the Mabru product manufacture date. 2. It is possible that there might exist a considerable time lag between the date a Mabru product is manufactured and the date it is put in service. For proof of the date that the Mabru product was put in service, Mabru will require a copy of the bill of sale from the Mabru product installer or a copy of the bill of sale showing the date of delivery from the new boat dealer to the original owner. Therefore, you should retain a copy of the dated bill of sale as evidence of the date of purchase or date of delivery.



+1 888 818 2814

support@mabrumarine.com

**5. TABLE OF WARRANTY PERIODS** Limited Warranty Periods MARINE AIR CONDITIONING MABRU – Direct Expansion SC Series Self Contained units OEM or Dealer Installed W/ included control 2 Year Warranty 1st Year parts and labor, 2nd Year parts only. Not to exceed three (3) years from date of production. MABRU – Air Handlers Chilled Water Systems OEM or Dealer Installed 2 Year Warranty 1st Year parts and labor, 2nd Year parts only. Not to exceed three (3) years from date of production. IMPORTANT NOTES: 1. Warranty periods begin from the date of possession of the boat by the first owner if OEM installed or date of installation if dealer installed, but not to exceed three (3) years from date of production. The warranty is transferable and will carry the remainder of the original owner’s warranty based on the original date of purchase or date of installation. 2. Proof of purchase or installation may be required to verify warranty coverage. 3. Any unit or replacement part installed due to a warranty failure carries the remainder of the original warranty. Warranty coverage does not start over from the repair/replacement date. 4. Warranty coverage shall not exceed three (3) years from the date of production. 5. These warranty periods are effective January 15, 2020.

MABRU – REPLACEMENT/MISCELLANEOUS PARTS Product Sale Type Warranty Coverage Pumps - 1 Year warranty, parts only Compressors Aftermarket sales 1 Year warranty, parts, only Replacement parts and components Aftermarket sales 90 Day warranty parts, only MARINE BATTERY CHARGERS Product Sale Type Warranty Coverage All sales types 1 Year Warranty, parts and labor Not to exceed three (3) years from date of manufacture. MABRU LITHIUM BATTERIES Standard Lithium – 2-year warranty Military Lithium – 3 Year warranty 6. MABRU CUSTOMER SERVICE DEPARTMENT Use the following information to contact Mabru Marine Customer and Technical Support. Telephone: +1 888 818 2814 or +1 954-467-1770 Email: [sales@mabrumarine.com](mailto:sales@mabrumarine.com) Mailing Address: Mabru Power Systems Warranty Department 1105 Old Griffin Road, Dania Beach, FL 33004 For all other areas visit our website to find your nearest distributor at [www.mabrumarine.com](http://www.mabrumarine.com) We are open from 8:00



+1 888 818 2814

[support@mabrumarine.com](mailto:support@mabrumarine.com)