

USE AND MAINTENANCE

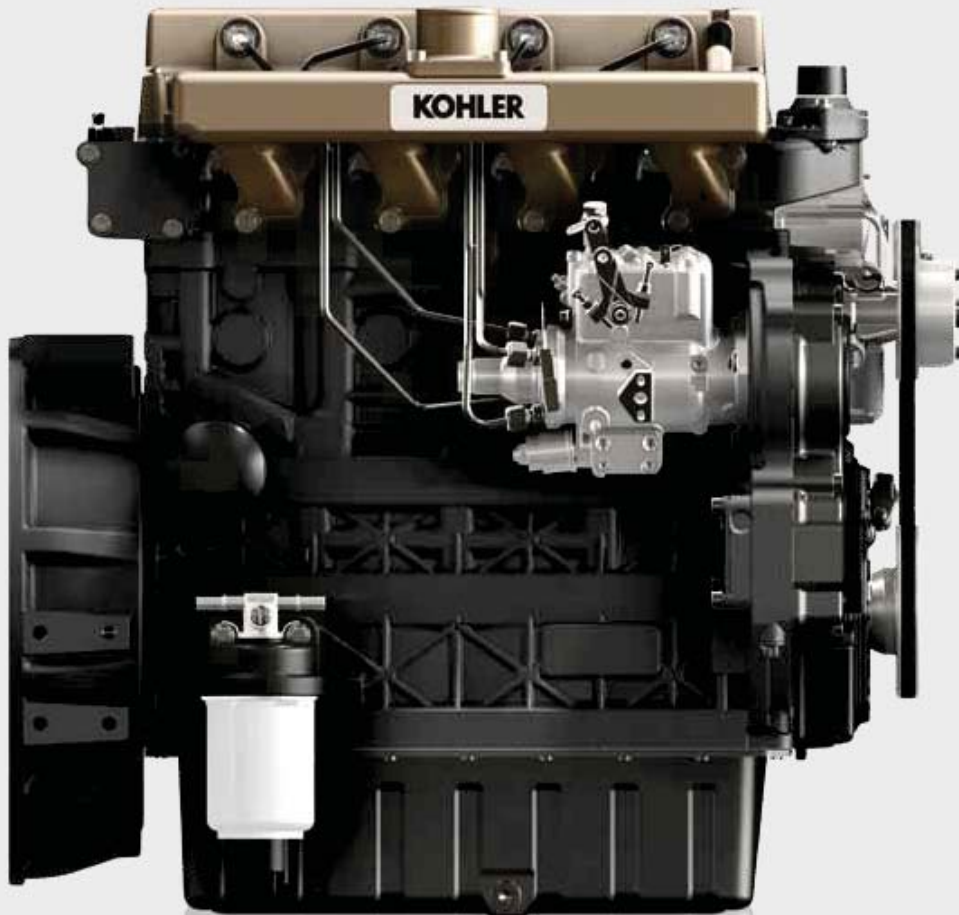

1903 M | 2504 M

KOHLER® Diesel KDI





REGISTRATION OF MODIFICATIONS TO THE DOCUMENT

Any modifications to this document must be registered by the drafting body, by completing the following table.

Drafting body	Code document	Model N°	Edition	Revision	Date issue	Date Review	Written by	Endorsed
DICOM/ATLO	ED0053029500	51270	1°	0	15/01/2013	15/01/2013		

The online manual s provided with hyperlinks that address you directly to each chapter. Clicking on:

- The analytic index titles you can go directly to the selected subject.
- The blue underlined words you can go directly to a paragraph, a table or a picture.
- The chapter titles (headings) you come back automatically to the chapter initial page.
- The paragraph titles the best script size for reading is displayed.
- The two icons (play  and stop ) aside some pictures you can reproduce multimedia videos.
- Clicking next to the bottom page number you come back to the analytic index.

EN

A

Air bleeding, Check on cooling circuit	28
Air filter cartridge replacement	34
Air filter check	28
Air intake hoses replacement	34
Alternator belt tension adjustment	38
Alternator belt tension check	27
Alternator belt replacement	33

B

Balancer shafts	37
Battery features	13
Bleeding the fuel system	33
Break-in period	20

C

Cartridge replacement, Air filter	34
Cartridge replacement, Oil filter	32
Check, Air filter	28
Check, Alternator belt tension	27
Check, Coolant level	25
Check, Fuel filter cartridge	25
Check of the radiator heat-exchanger surface	26
Check, Oil level	25
Check on cooling circuit - Air bleeding	28
Check, Pre-start	20
Check, Rubber hoses	26
Cylinder head, Oil dipstick on	36
Component identification, Engine	7
Coolant level check	25
Coolant	13
Coolant filling	22
Coolant replacement	31
Cooling circuit - Air bleeding, Check on	28
Cooling circuit hoses replacement	34

D

Definitions, Glossary and	6
Description, Safety signal	17
Dimensions, Engine	10
Disposal and scrapping	35

E

Electric pump	36
Engine component identification	7
Engine dimensions	10
Engine, General description of the	10
Engine oil replacement	30
Engine, Location of safety signals on	18
Engine specifications	10
Engine starting after storage	29
Engine storage (up to 6 months)	29
Engine storage (over 6 months)	29

F

Features, Battery	13
Filter check, Air	28
Filter cartridge replacement, Air	34
Filter cartridge replacement, Oil	32
Filter (cartridge replacement), Remote oil	37
Filling, Coolant	22
Filling, Oil	21
Fuel	11
Fuel filter cartridge check	25
Fuel filter cartridge replacement	32
Fuel system, Bleeding the	33

G

General description of the engine	10
General remarks	14
Glossary and Definitions	6

H

Heat-exchanger surface, Check of the radiator.....	26
Heater (replacement).....	36
Hoses check, Rubber.....	26
Hoses replacement, Cooling circuit.....	34

I

Identification, Engine component.....	7
Identification data, Manufacturer and motor.....	8
Information and safety signals.....	16
Information, Safety.....	14

L

Level check, Coolant.....	25
Level check, Oil.....	25
Location of safety signals on engine.....	18

M

Maintenance, Periodic.....	24
Manual's purpose.....	6
Manufacturer and motor identification data.....	8
Manufacturer's warranty coverage.....	40
Motor identification data, Manufacturer and.....	8

O

Oil.....	11
Oil dipstick on cylinder head.....	36
Oil filter (cartridge replacement), Remote.....	37
Oil filter cartridge replacement.....	32
Oil filling.....	21
Oil level check.....	25
Oil replacement, Engine.....	30
Owner's warranty responsibilities.....	40

P

Period, Break-in.....	20
Periodic maintenance.....	24
Precautions, Safety.....	18
Pre-start check.....	20
Product preservation.....	29
PTO, 3 rd	37
PTO, 4 rd	37
Purpose, Manual's.....	6

R

Remote oil filter (cartridge replacement).....	37
Remarks, General.....	14
Replacement, Air filter cartridge.....	34
Replacement, Air intake hoses.....	34
Replacement, Alternator belt.....	33
Replacement, Coolant.....	31
Replacement, Cooling circuit hoses.....	34
Replacement, Engine oil.....	30
Replacement, Fuel filter cartridge.....	32
Replacement, Oil filter cartridge.....	32
Request, Service.....	6
Rubber hoses check.....	26

S

Safety information.....	14
Safety signals, Information and.....	16
Safety signal description.....	17
Safety signals on engine, Location of.....	18
Safety precautions.....	18
Safety and environmental impact.....	17
Scrapping, Disposal and.....	35
Service request.....	6
Shafts, Balancer.....	37
Specifications, Engine.....	10
Starting after storage, Engine.....	29
Starting and turning off.....	20

<i>Storage, Engine starting after</i>	<i>29</i>
<i>Storage (up to 6 months), Engine</i>	<i>29</i>
<i>Storage (over 6 months), Engine</i>	<i>29</i>

T

<i>Tension adjustment, Alternator belt</i>	<i>38</i>
<i>Tension check, Alternator belt</i>	<i>27</i>
<i>Turning off, Starting and.....</i>	<i>20</i>

U

<i>Useful information about failures</i>	<i>39</i>
<i>Useful information about maintenance.....</i>	<i>24</i>

W

<i>Warranty coverage, Manufacturer's</i>	<i>40</i>
<i>Warranty responsibilities, Owner's</i>	<i>40</i>

Manual's purpose

- This manual contains the instructions needed to carry out a proper use and maintenance of the engine, therefore it must always be available, for future reference when required.
- This manual is an integral part of the engine, in the event of transfer or sale, it must be always attached to it.
- Safety pictograms can be found on the engine and it is the operator's responsibility to keep them in a perfectly visible place and replace them when they are no longer legible.
- Information, description and pictures in this manual reflect the state of the art at the time of the marketing of engine.
- However, development on the engines is continuous. Therefore, the information within this manual is subject to change without notice and without obligation.
- **KOHLER** reserves the right to make, at any time, changes in the engines for technical or commercial reasons.
- These changes do not require **KOHLER** to intervene on the marketed production up to that time and not to consider this manual as inappropriate.
- Any additional section that **KOHLER** will deem necessary to supply some time after the main text shall be kept together with the manual and considered as an integral part of it.
- The information contained within this manual is the sole property of **KOHLER**. As such, no reproduction or replication in whole or part is allowed without the express written permission of **KOHLER**.

Glossary and Definitions

The paragraphs, tables and figure are divided into chapter with their progressive numbers.

Ex: **Par. 1.3** - chapter 1 paragraph 3.

Tab. 2.4 - chapter 2 table 4.

Fig. 4.5 - chapter 4 figure 5.

The references of the objects described in the text and in figure and number are indicated by letters, which are always and only related to the paragraph you are reading unless there are specific references to other figures or paragraphs.

The figure are based on model 2504 M, where necessary the version 1903 M is illustrated.

All data, measurements and relevant symbols are shown in the table below.

DATA	MEASUREMENT	SYMBOL	EXAMPLE
Dimension	millimeter	mm	1 mm
Torque	newton-meter	Nm	1 Nm
Force	newton	N	1 N
Weight	Kilogram	Kg	1 kg
Volume	cubic centimeter	cm ³	1 cm ³
Barometric	pascal	Pa	1 Pa
Liquids	liter	lt.	1 lt.
Angle	grade	α	1°
Power	kiloWatt	kW	1 kW
Temperature	centigrade degree	°C	1°C

Service request

- Our authorised service centres can be found in the service handbook (received with the product purchased).
- The complete and updated list of authorized Kohler service centres can be found on our web site: <http://www.lombardinigroup.it/dealer-locator>

Engine component identification

SIDE VIEW A

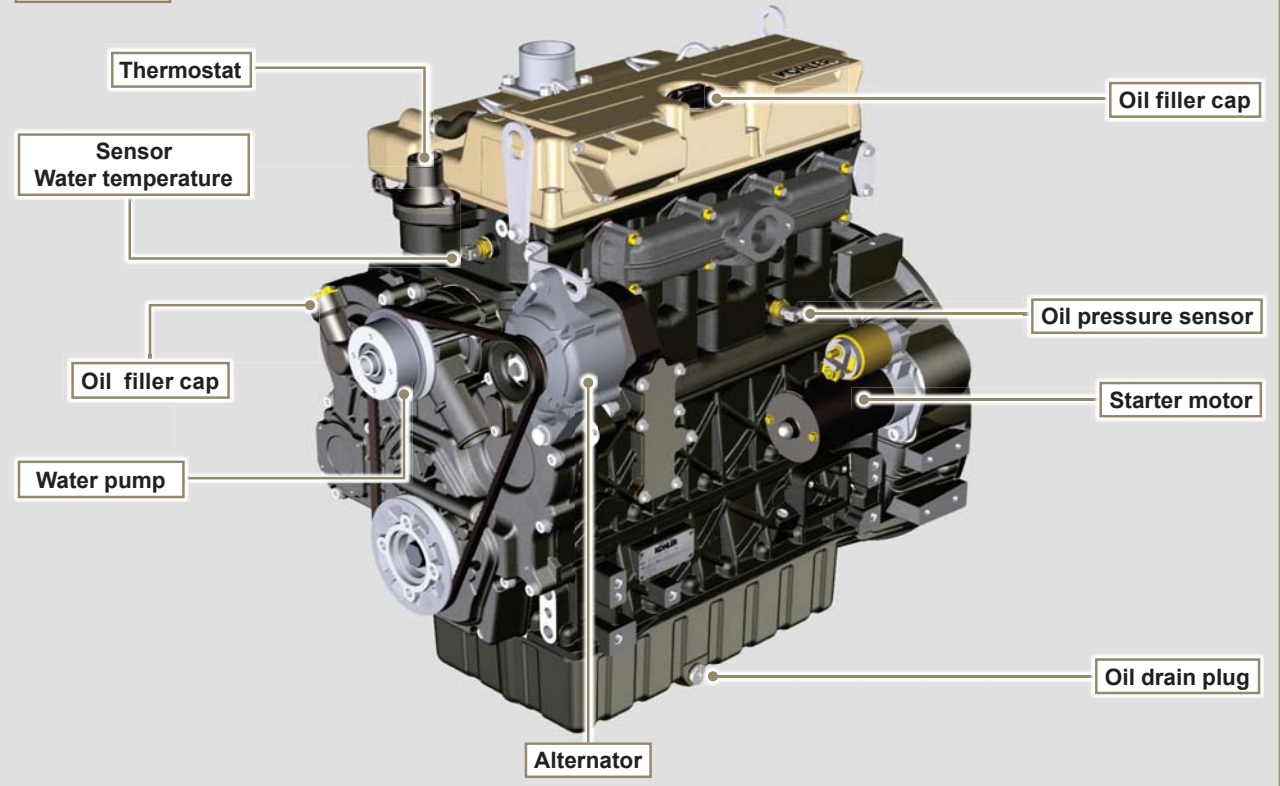

SIDE VIEW B

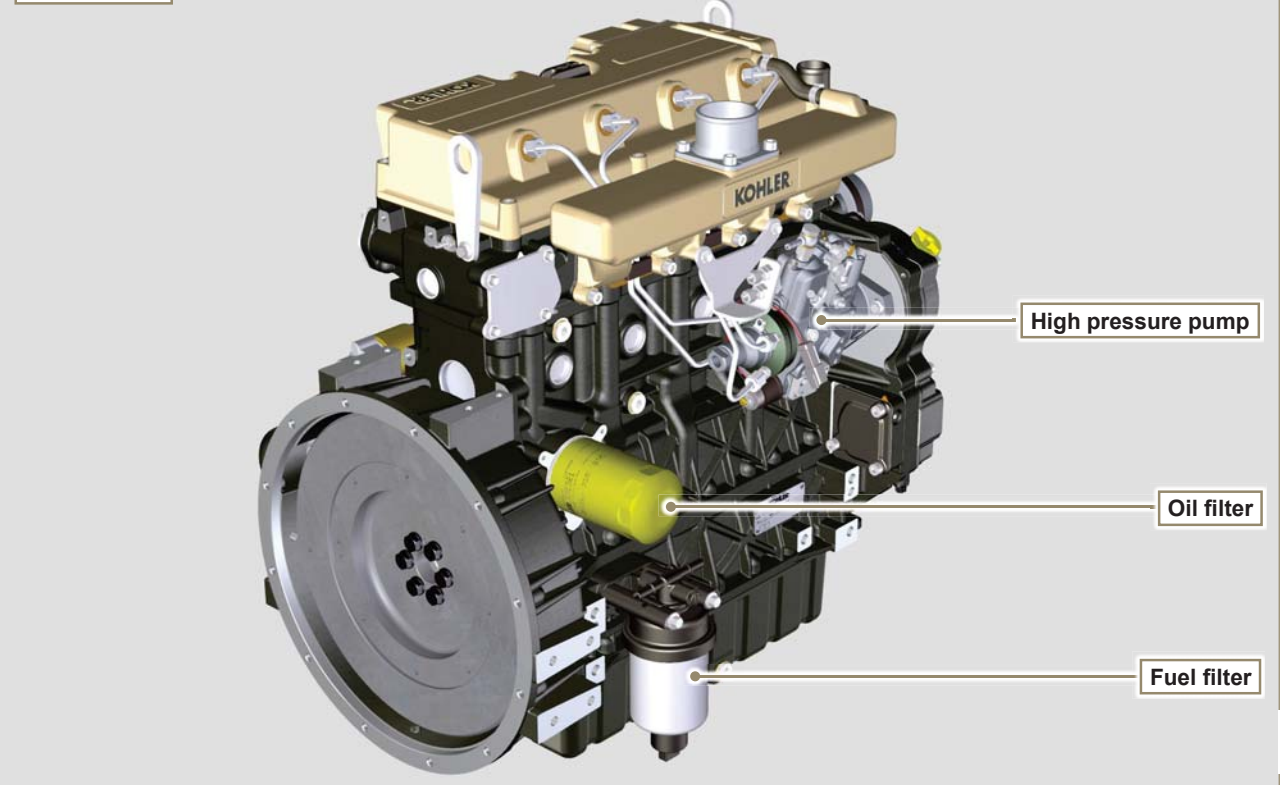

Manufacturer and motor identification data

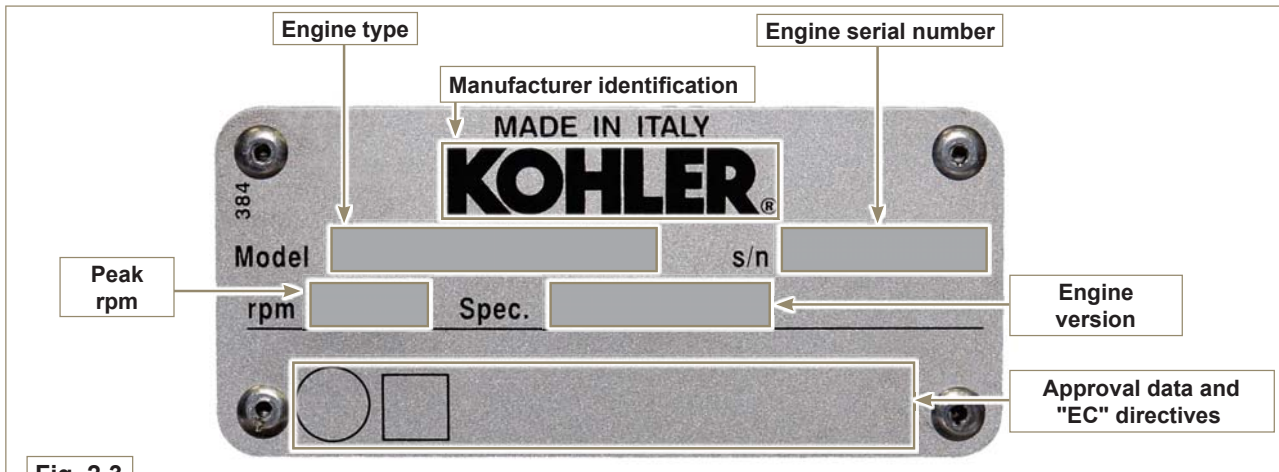
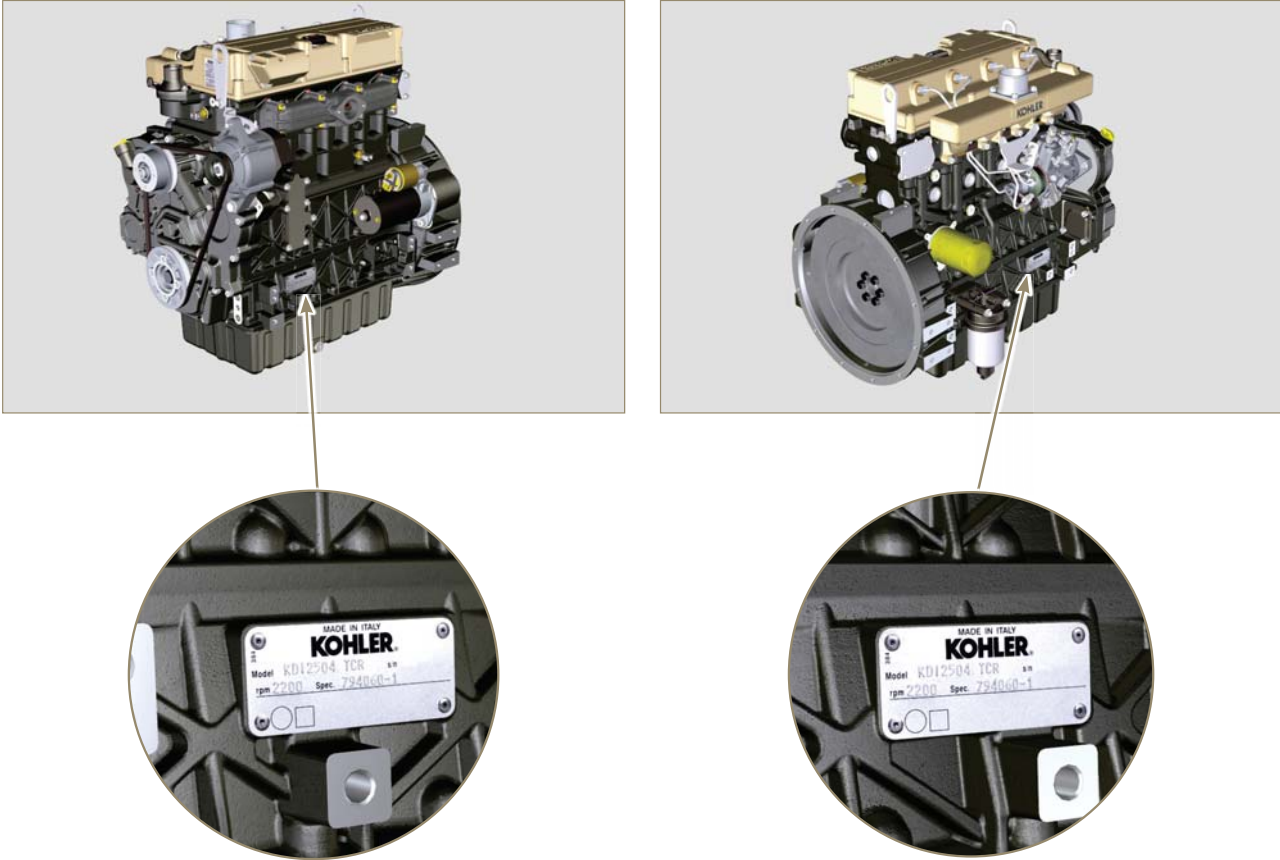



Fig. 2.3

1.1. General description of the engine

- 4-stroke, in-line cylinders Diesel engine;
- Liquid-cooling system;
- 4 valves per cylinder with hydraulic tappets;
- Injection.

1.2 Engine specifications

Tab. 1.1

TECHNICAL DATA		UNIT OF MEASURE		
			KDI 1903 M	KDI 2504 M
ENGINE TYPE				
CYLINDERS		n.	3	4
BORE		mm	88	
STROKE		mm	102	
DISPLACEMENT		cm ³	1861	2482
MAX INCLINATION DURING OPERATION (even in combined)		$\alpha\tau$	30° max. 30 minuti	
		$\alpha\tau$	35° max.1 minuto	
OIL CAPACITY (MAX level.)	including oil filter	lt.	8.7	11.0
	with dynamic balancer (optional)	lt.		10.7
DRY WEIGHT		Kg	233	267

1.3 Engine dimensions (mm)

KDI 1903 M

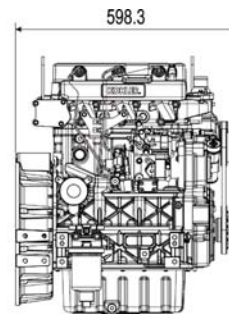
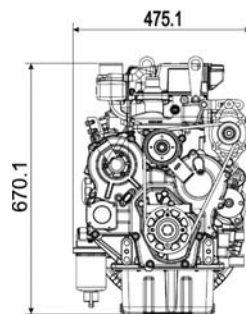

KDI 2504 M

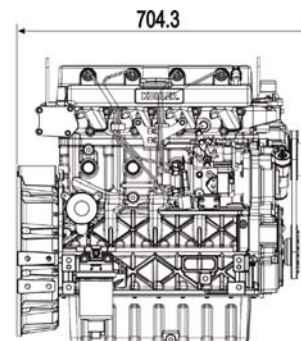
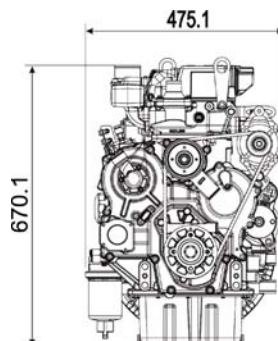

1.4 Oil



Important

- The engine may be damaged if operated with improper oil level.
- Do not exceed the MAX level because a sudden increase in engine rpm could be caused by its combustion.
- Use only the recommended oil to ensure adequate protection, efficiency and service life of the engine.
- The use of lubricants other than recommended may shorten the engine life.
- Viscosity must be appropriate to the ambient temperature to which the engine is to be exposed (**Par. 1.4.1**).

1.4.1 SAE oil classification

- In the SAE classification, oils are identified according to viscosity without considering any other qualitative characteristic.



Danger

- Prolonged skin contact with the exhausted engine oil can cause cancer of the skin.
- If contact with oil cannot be avoided, thoroughly wash your hands with soap and water as soon as possible.
- For the exhausted oil disposal, refer to [Par. 5.10 DISPOSAL and SCRAPPING](#).

- The code is made up of two numbers. The first number refers to the viscosity when cold, for use during winter ("W"= winter), while the second number is for viscosity at high temperatures.

Tab. 1.2

RECOMMENDED OIL		
VISCOSITY	SAE	10W-40 / 5W-40
WITH SPECIFICATIONS	API	CI-4, CH-4, CG-4
	ACEA	E4 - E5 - E7

CLASSIFICATION	DESCRIPTION ACEA SPECIFICATION
E4	High performance (Euro 1 - 2 - 3 Engines) heavy duty
E5	High performance (Euro 1 - 2 Engines) heavy duty
E7	High power over long distances (Euro 4 - 5 engines)

1.5 Fuel



Important

- Use the same type of diesel fuel as used in cars (EN 590 for E.U. - ASTM D975-09B regulation - Grade 1e2). Use of other types of fuel could damage the engine. Do not use dirty diesel fuel or mixtures of diesel fuel and water since this would cause serious engine faults.



Warning

- Clean fuel prevents the fuel injectors from clogging. Immediately clean up any spillage during refuelling.
- Never store diesel fuel in galvanized containers (i.e. coated with zinc). Diesel fuel and the galvanized coating react chemically to each other, producing flaking that quickly clogs filters or causes fuel pump and/or injector failure.

1.5.1 Fuel for low temperatures

- For the operation of the engine at temperatures lower than 0 ° C suitable for use fuels normally distributed by the oil companies and in any case corresponding to the specifications of [Tab. 1.3](#).
- These fuels reduce the formation of paraffin in diesel at low temperatures.
- When paraffin forms in the diesel, the fuel filter becomes blocked interrupting the flow of fuel.

1.5.2 Biodiesel fuel

- Fuels containing less than 10% methyl ester or B10, are suitable for use in this engine provided that they meet the specifications listed in the **Tab. 1.3**.
- DO NOT USE** vegetable oil as a biofuel for this engine.
- Any failures resulting from the use of fuels other than recommended will not be warranted.

Tab. 1.3

FUEL COMPATIBILITY								
	Compatible		Certification emission		Warranty coverage		Engine waste	
	yes	no	yes	no	yes	no	yes	no
EN 590, DIN 51628 - Military NATO fuel F-54 (S=10 ppm)			(2)					
No 1 Diesel (US) - ASTM D 975-09 B - Grade 1-D S 15 (S=15 ppm)			(3)					
No 1 Diesel (US) - ASTM D 975-09 B - Grade 1-D S 500 (S=500 ppm)								
No 2 Diesel (US) - ASTM D 975-09 B - Grade 2-D S 15			(3)					
No 2 Diesel (US) - ASTM D 975-09 B - Grade 2-D S 1500								
ARCTIC (EN 590/ASTM D 975-09 B)	(1)		(3)					
High sulfur fuel < 5000 ppm (<0.5%)								
High sulfur fuel > 5000 ppm (>0.5%)								
High sulfur fuel > 10000 ppm (>1%)								
Civil Jet Fuels Jet A/A1								(1)
Civil Jet Fuels Jet B								
Bio Fuels (EN14214). Max. 30%								
Bio Fuels (ASTM D 6751-09a). Max. 30%								

(1) Without adding oil.

(2) Stage 3A.

(3) EPA TIER III.

1.6 Coolant**TECHNICAL SPECIFICATIONS****50% ANTIFREEZE and 50% WATER****1.7 Battery features****Battery not supplied by Kohler**

RECOMMENDED BATTERIES	
AMBIENT TEMPERATURE	BATTERY TYPE
da 0 a -25°C	120 Ah - 800 A/DIN 120 Ah - 1560 A/EN

2.1 Safety information

- The intended use of the engine is in conformity with the machine on which it is mounted.
- Any use of the machine other than that described cannot be considered as complying with its intended purpose as specified by **KOHLER**.
- **KOHLER** declines all responsibility for any change to the engine not described in this manual made by unauthorised **KOHLER** personnel.
- A proper use of the engine, a strict observance of the rules listed below and the rigorous application of all these precautions will avoid the risk of accidents or injuries.
- Those who carry out the use and maintenance on the engine must wear the safety equipment and the accident-prevention guards.
- **KOHLER** declines all direct and indirect liability for failure to comply with the standards of conduct contained in this manual.
- **KOHLER** cannot consider every reasonably unforeseeable misuse that may cause a potential danger.

2.2 General remarks

- When installing the **KDI** engines, always bear in mind that any variation to the functional systems may involve serious failures to the engine.
- Any improvement must be verified at **KOHLER** testing laboratories before application of the engine.
- In case the approval to a modification is not granted, **KOHLER** shall not be deemed responsible for any consequential failures or damages to the engine.
- The engine may only be assembled on a machine by personnel specifically trained by **KOHLER** and who work in compliance with the existing documentation.
- The engine has been built to the specifications of a machine manufacturer, and it is his responsibility to ensure that all necessary action is taken to meet the essential and legally prescribed health and safety requirements. Any use of the machine other than that described cannot be considered as complying with its intended purpose as specified by **KOHLER**, which therefore declines all responsibility for accidents caused by such operations.
- The following indications are dedicated to the user of the machine in order to reduce or eliminate risks concerning engine operation and the relative routine maintenance work.
- The user must read these instructions carefully. Failure to do this could lead to serious danger for his personal safety and health and that of any persons who may be in the vicinity of the machine.
- On starting, make sure that the engine is as horizontal as possible, unless the machine specifications differ.
- Make sure that the machine is stable to prevent the risk of overturning.
- The engine must not operate in places containing inflammable materials, in explosive atmospheres, where there is dust that can easily catch fire unless specific, adequate and clearly indicated precautions have been taken and have been certified for the machine.
- To prevent fire hazards, always keep the machine at least one meter from buildings or from other machinery.
- Children and animals must be kept at a due distance from operating machines in order to prevent hazards deriving from their operation.
- Make sure that no soundproofing panels and the ground or floor on which the machine is standing have not soaked up any fuel.
- Fuel vapour is highly toxic. Only refuel outdoors or in a well ventilated place.
- Do not smoke or use naked flames when refuelling.
- During operation, the surface of the engine can become dangerously hot. Avoid touching the exhaust system in particular.
- Before proceeding with any operation on the engine, stop it and allow it to cool.
- Always open the radiator plug or expansion chamber with the utmost caution, wearing protective garments and goggles.
- The coolant fluid is under pressure. Never carry out any inspections until the engine has cooled.
- If there is an electric fan, do not approach the engine whilst it is still hot as the fan could also start operating when the engine is at a standstill.
- The oil must be drained whilst the engine is hot (oil T ~ 80°C). Particular care is required to prevent burns. Do not allow the oil to come into contact with the skin because of the health hazards involved.
- During operations that involve access to moving parts of the engine and/or removal of rotating guards, disconnect and insulate the negative wire (-) of the battery to prevent accidental short-circuits and to stop the starter motor from being energized.
- Check belt tension only when the engine is off.
- Fully tighten the tank plug each time after refuelling. Do not fill the tank right to the top but leave an adequate space for the fuel to expand.

EN

- Fuel and oil are inflammable. The tank must only be filled when the engine is off. Before starting, dry any spilt fuel.

- To start the engine follow the specific instructions provided in the engine and/or machine operating manual. Do not use auxiliary starting devices not originally installed on the machine (e.g. Startpilot).
- Before starting, remove any tools that were used to service the engine and/or machine. Make sure that all guards have been refitted.
- Do not mix fuel with elements such as oil or kerosene. Failure to comply with this prohibition will cause the non-operation of the catalyst and non-observance of the emissions declared by **KOHLER**.
- Pay attention to the temperature of the oil filter when the filter itself is replaced.
- Only check, top up and change the coolant fluid when the engine is off and reached the ambient temperature. Coolant fluid is polluting, it must therefore be disposed of in the correct way.
- Do not use air and water jets at high pressures on cables, connectors and injectors.
- Only use the eyebolts **A** installed by **KOHLER** to move the engine (**Fig. 2.1**).
- The angle between each lifting chain and the eyebolts shall not exceed 15° inwards.
- The correct tightening of the lifting screws is 25Nm.
- Do not interpose spacers or washers between the eyebolts and engine head.
- Provided that the above requirements are met, if the lifting eyebolts are subject to permanent deformation (inwards), all subsequent lifting operations must be performed in order to prevent them from bending in the opposite direction.

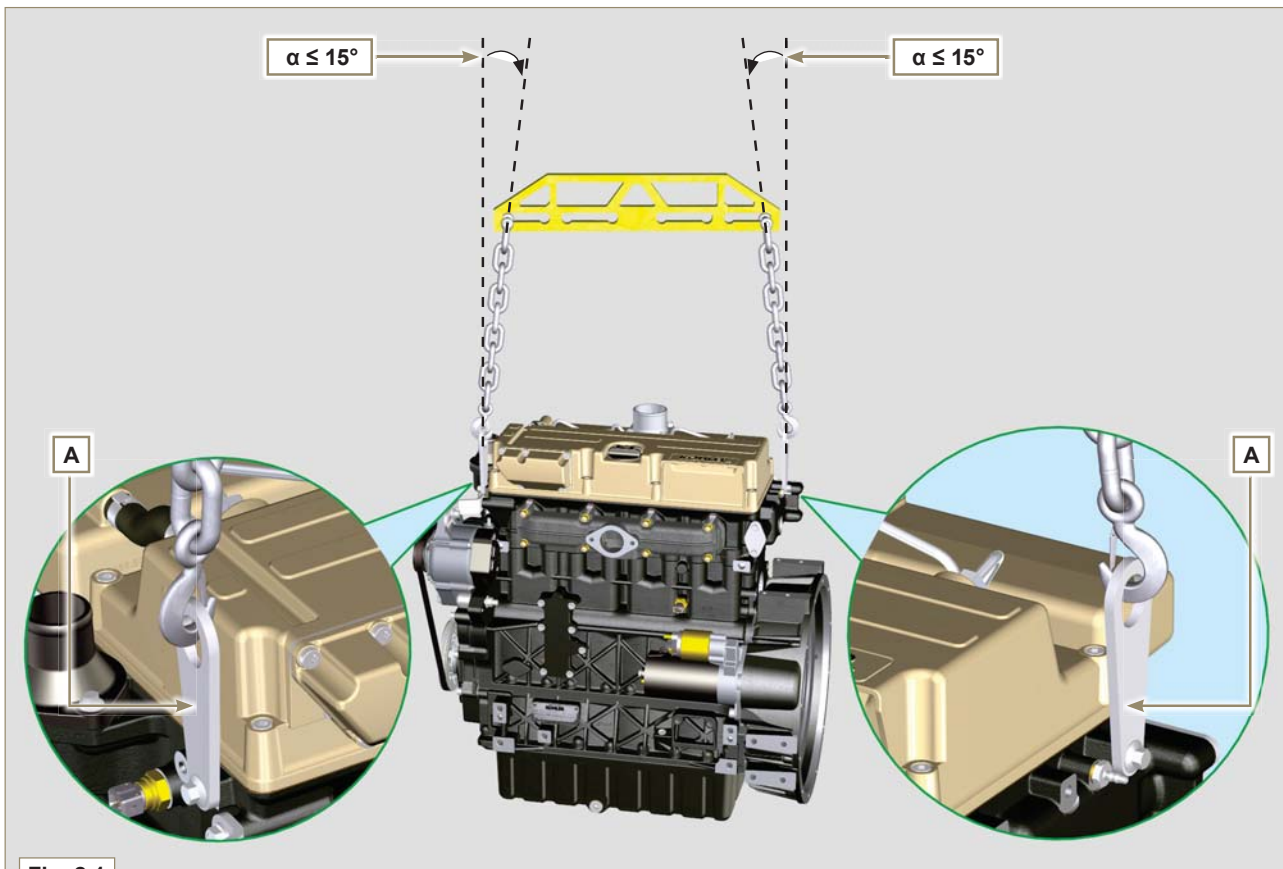

Fig. 2.1

2.3 Information and safety signals

	ACCIDENTAL START
	Accidental Starts can cause severe injury or death.
<i>Before working on the engine or equipment, disconnect the battery negative (-) wire.</i>	

	HOT PARTS
	Hot Parts can cause severe burns.
<i>Engine components can get extremely hot from operation. Do not touch engine while operating or just after stopping. Never operate the engine with heat shields or guards removed.</i>	

	ROTATING PARTS
	Rotating Parts can cause severe injury.
<i>Stay away while engine is in operation. Keep hands, feet, hair, and clothing away from all moving parts to prevent injury. Never operate the engine with covers, shrouds, or guards removed.</i>	

	LETHAL EXHAUST GASES
	Carbon Monoxide can cause severe nausea, fainting or death.
<i>Avoid inhaling exhaust fumes and never run the engine in a closed building or confined area. Carbon monoxide is toxic, odorless, colorless, and can cause death if inhaled.</i>	

	ELECTRICAL SHOCK
	Electrical Shock can cause injury.
<i>Do not touch wires while engine is running.</i>	

	HIGH PRESSURE FLUID RISK OF PUNCTURE
	High Pressure Fluids can puncture skin and cause severe injury or death.
<i>Do not work on fuel system without proper training or safety equipment. Fluid puncture injuries are highly toxic and hazardous. If an injury occurs, seek immediate medical attention.</i>	

	EXPLOSIVE FUEL
	Explosive fuel can cause fires and severe burns.
<i>Fuel is flammable and its vapours can ignite. Store fuel only in approved containers, in well ventilated, unoccupied buildings. Do not fill the fuel tank while the engine is hot or running, since spilled fuel could ignite if it comes in contact with hot parts or sparks from ignition. Do not start the engine near spilled fuel. Never use fuel as a cleaning agent.</i>	

	EXPLOSIVE GAS
	Explosive Gas can cause fires and severe acid burns.
<i>Charge battery only in a well ventilated area. Keep sparks, open flames, and other sources of ignition away from the battery at all times. Batteries produce explosive hydrogen gas while being charged. Keep batteries out of the reach of children. Remove all jewelry when servicing batteries. Before disconnecting the negative (-) ground cable, make sure all switches are OFF. If ON, a spark will occur at the ground cable terminal which could cause an explosion.</i>	

CALIFORNIA WARNING - DECLARATION 65

Engine exhaust from this product contains chemicals known to the State of California to cause cancer, birth defects, or other reproductive harm.

2.4 Safety signal description

- To ensure safe operation please read the following statements and understand their meaning.
- Also refer to your equipment manufacturer's manual for other important safety information.

- This manual contains safety precautions which are explained below.
- Please read them carefully.



Read the Operation and Maintenance handbook before performing any operation on the engine.



Use protective gloves before carrying out the operation.



Hot Parts.
Danger of burns.



Use protective glasses before carrying out the operation.



Presence of rotating parts.
Danger of jamming or cutting.



Use sound absorbing protections before carrying out the operation.



Presence of explosive fuel.
Danger of fire or explosion.



Lifting point.



Presence of steam and pressurized coolant.
Danger of burns.



Electrical shock.
Danger of severe scalding or death.



Danger

- This indicates situations of grave danger which, if ignored, may seriously threaten the health and safety of individuals.



High pressure fluid.
Danger of fluid penetration.



Important

- This indicates particularly important technical information that should not be ignored.



Lethal Exhaust Gases.
Danger of poisoning or death.



Warning

- This indicates that failure to comply with it can cause minor damage or injury.

2.5 Safety and environmental impact

Every organisation has a duty to implement procedures to identify, assess and monitor the influence of its own activities (products, services, etc.) on the environment. Procedures for identifying the extent of the impact on the environment must consider the following factors:

- Liquid waste.
- Waste management.
- Soil contamination.
- Atmospheric emission.
- Use of raw materials and natural resources.
- Regulations and directives regarding environmental impact.

In order to minimise the impact on the environment, **KOHLER** now provides a number of indications to be followed by all persons handling the engine, for any reason, during its expected lifetime.

- All packaging components must be disposed of in accordance with the laws of the country in which disposal is taking place.
- Keep the fuel and engine control systems and the exhaust pipes in efficient working order to limit environmental and noise pollution.
- When discontinuing use of the engine, select all components according to their chemical characteristics and dispose of them separately.

2.6 Safety precautions

- Check the good condition of safety signals.
- The user must replace them with original ones if they are deteriorated and illegible. Ask for new safety signals to the manufacturer.
- Position them as shown in **Par. 2.7**.
- Clean with a cloth, water and soap.

2.7 Location of safety signals on engine

KDI 1903 M

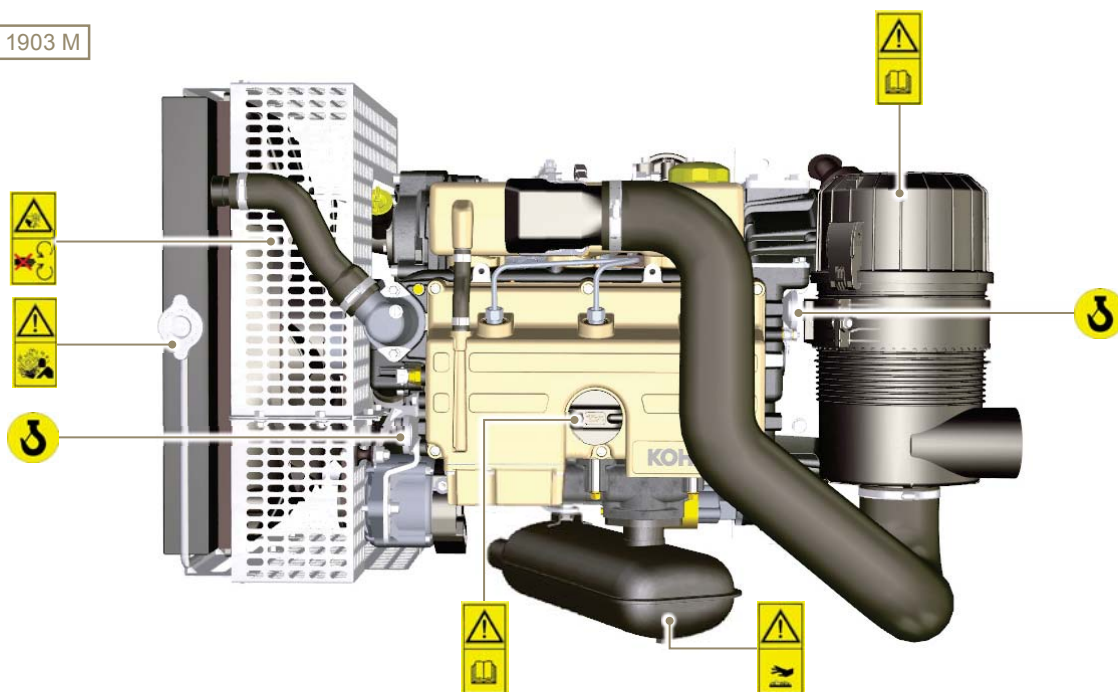

KDI 2504 M

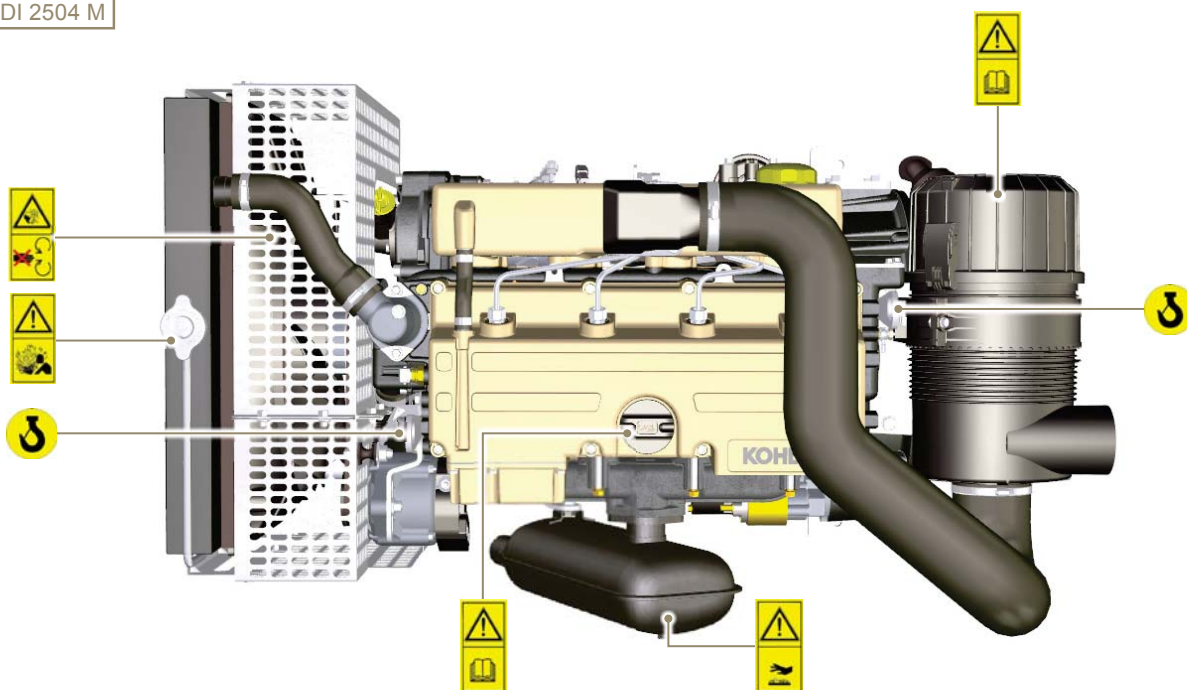

3.1 Pre-start check

- Read carefully the following pages and carry out the operations described below in accordance with the instructions specified.
- Increase the frequency of maintenance operations in heavy working conditions (engine starts but stops, very dusty and hot environments, etc...).



Important

- Non compliance with the operations described in the following pages involves the risk of damages to the engine and vehicle on which it is installed as well as personal and/or property damage.

3.2 Break-in period

NOTE: For the first 50 hours of engine operation, it is advisable not to exceed 75% of the maximum power supplied.

3.3 Starting and turning off

3.3.1 Starting

- 1 - Check the level of the engine oil, fuel and coolant.
- 2 - Put the ignition key on the control panel.
- 3 - Turn the key to **ON** position.
- 4 - Turn the key beyond the **ON** position and release it when the engine starts (the key will return into ON position automatically).



Important

- Do not actuate the starter for more than 15 seconds at a time. If the engine does not start, wait for one minute before repeating attempt.
- If engine does not start after two attempts see [Tab. 8.1](#) and [Tab. 8.2](#), to found the cause.

3.3.2 After starting



Warning

- Make sure that when the engine is running, all pilot lights are off.
- 1 - Run at minimum speed for a few minutes according to table.

AMBIENT TEMPERATURE	TIME
≤ -20°C	2 minutes
from -20° C to -10°C	1 minutes
from -10° C to -5° C	30 seconds
from -5° C to 5° C	20 seconds
≥ 5° C	15 seconds

3.3.3 Turning off

- 1 - Do not turn off the engine when it is running at the maximum rotation speed.
- 2 - Before turning it off, keep it idle at minimum speed for about 1 minute.
- 3 - Turn the key to **OFF** position.

3.4 Refuelling



Danger

- The only approved fuels are those listed in [Tab. 1.3](#).
- In those countries where diesel has a high sulphur content, it is advisable to lubricate the engine with a high alkaline oil or alternatively to replace the lubricating oil recommended by **KOHLER** more frequently.
- To avoid explosions or fire outbreaks, do not smoke or use naked flames during the operations.
- Fuel vapours are highly toxic. Only carry out the operations outdoors or in a well ventilated place.
- Keep your face well away from the plug to prevent harmful vapours from being inhaled.
- Dispose of fuel in the correct way and do not litter as it is highly polluting.
- When refuelling, it is advisable to use a funnel to prevent fuel from spilling out. The fuel should also be filtered to prevent dust or dirt from entering the tank.

Do not overfill the fuel tank. Leave room for the fuel to expand.

NOTE: At the first refuelling or if the tank remains empty [Bleeding the fuel system \(Par. 5.5\)](#).

3.5 Oil filling



Important

- For safety precautions see [Par. 1.4](#).
- Before proceeding see [Par. 6.6](#).

- 1 - Loosen the oil filler cap **A** or the oil filler cap **C** if the cap **A** is not accessible.

- 2 - Add the type and amount of oil recommended ([Tab. 1.3](#)).

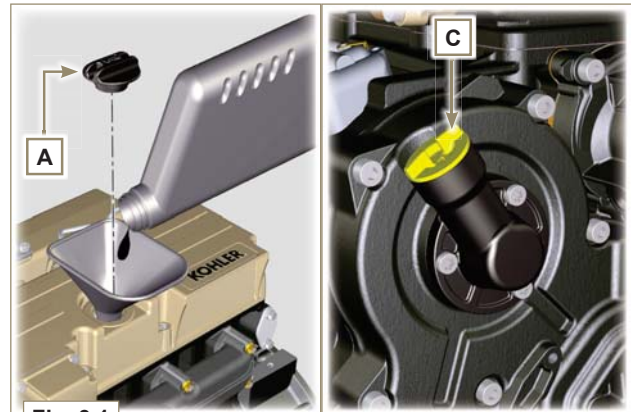

Fig. 3.1

- 3 - Remove the oil dipstick **B** and check that the level is up to but does not exceed the **MAX**.

- 4 - If level is not at the **MAX**. level, fill up. **F** it again the oil dipstick **B** correctly.

- 5 - Re-tighten the cap **A** or **C**.

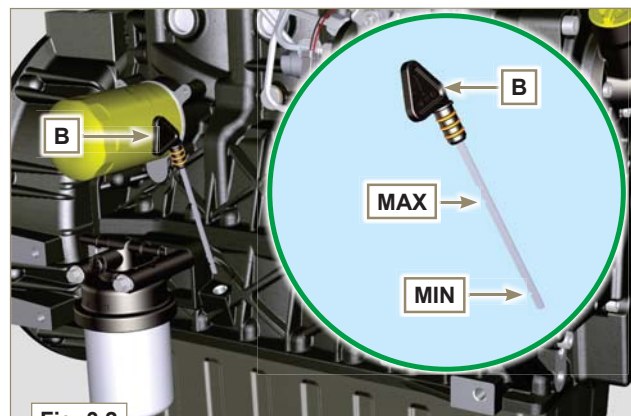
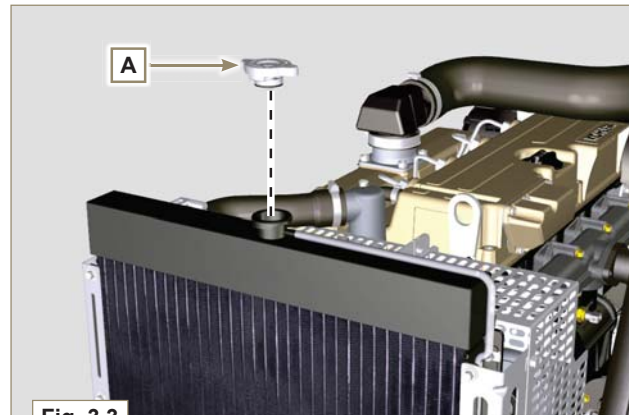

Fig. 3.2

3.6 Coolant filling**Warning**

- An anti-freeze protection liquid (ANTIFREEZE) - mixed with decalcified water - must be used.
- The freezing point of the refrigerant mixture depends on the amount concentration in water.
- As well as lowering the freezing point, the permanent liquid also raises the boiling point.
- It is so advisable a 50% mixture that ensure a general protection degree.

- 1 - Loosen the cap **A** and fill the radiator with coolant composed of:
50% ANTIFREEZE and 50% water.
- 2 - Top liquid up until the pipes inside the radiator are covered by about 5 mm.
Do not overfill the radiator, but leave room for the fuel to expand.
- 3 - For engines equipped with expansion tank, pour in fluid until reaching the max level mark.
- 4 - Re-tighten the cap **A**.
- 5 - Bleeding the cooling circuit as indicated in the [Par. 4.8](#).
- 6 - After a few working hours, allow the engine to cool down, and check again the coolant level.

**Fig. 3.3**

4.1 Useful information about maintenance

- This chapter shows all operations described in the **Tab. 4.1** and **Tab. 4.2** that may be directly carried out by the user.
- Periodic inspection and maintenance operations must be carried out as indicated in this manual and are charged to the user.
- Failure to comply with these regulations and maintenance intervals involves the risk of technical damage to the engine. Any non compliance makes the warranty become null and void.
- In order to prevent personal and property damage read carefully the instructions reported below before proceeding with any operation on the engine.



Warning

- Inspections must be made when the engine is off and cold.
- Place engine on level surface to ensure accurate measurement of oil level.
- Before any starting, to avoid spillages of oil make sure that:
 - the oil dipstick is inserted correctly;
 - also check that:
 - oil drain plug and
 - oil filler cap are tightened firmly.

4.2 Periodic maintenance

The intervals of preventive maintenance in **Tab. 4.1** and **Tab. 4.2** refer to the engine operating under normal operating conditions with fuel and oil meeting the recommended specifications.

Tab. 4.1

CLEANING AND CHECKING						
OPERATION DESCRIPTION	PERIODICITY (HOURS)					PAR.
	10	200	500	1000	5000	
Engine oil level						4.4
Coolant level						4.3
Dry-type air filter ⁽²⁾						--
Radiator heat-exchange surface						4.6
Alternator belt tension						7.1
Rubber hoses						4.7
Starter Motor						--
Alternator						--
Fuel hose						--

Tab. 4.2

REPLACEMENT						
OPERATION DESCRIPTION	PERIODICITY (HOURS)					PAR.
	10	200	500	1000	5000	
Engine oil ⁽¹⁾						5.1
Oil filter cartridge ⁽¹⁾						5.3
Fuel filter cartridge ⁽¹⁾						5.4
Alternator belt ⁽³⁾						5.6
Coolant ⁽⁴⁾ (interior radiator cleaning)						5.2
Intake manifold sleeve (air filter - intake manifold)						5.9
Coolant hoses						5.7
Dry air cleaner external cartridge ⁽²⁾	After 6 checks with cleaning					5.8
Fuel hose	The replacement must be carried out by authorized KOHLER workshops					

(1) - In case of low use: 12 months.

(3) - In case of low use: 36 months.

EN (2) - The period of time that must elapse before checking the filter element depends on the environment in which the engine operates. The air filter must be cleaned and replaced more frequently under very dusty conditions.

(4) - In case of low use: 24 months.

4.3 Coolant level check

1 - Loosen the cap **A** and top liquid up until the pipes inside the radiator are covered by 5 mm.

NOTE: Component not necessarily supplied by KOHLER.

2 - Top up if necessary.

3 - Do not overfill the radiator, but leave room for the fuel to expand.

4 - Re-tighten the cap **A**.

5 - Check for leaks near the hose clamps.

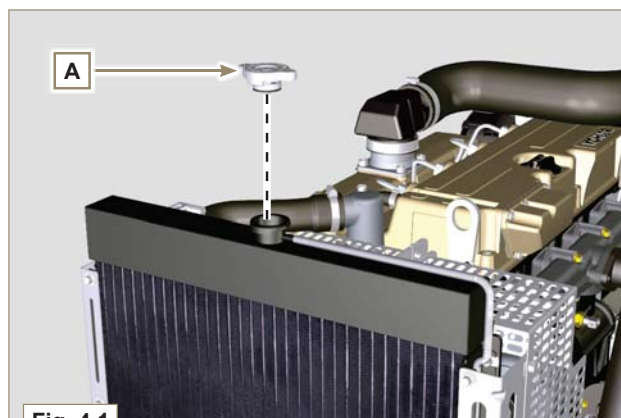

Fig. 4.1

4.4 Oil level check

1 - Remove the oil dipstick **B** and check that the level is up to **MAX**.

2 - Pour in fluid until reaching the **MAX** level mark.

3 - Reinstall the oil dipstick **B** correctly.

4 - Re-tighten the cap **A** and/or **C** (Fig. 4.3).

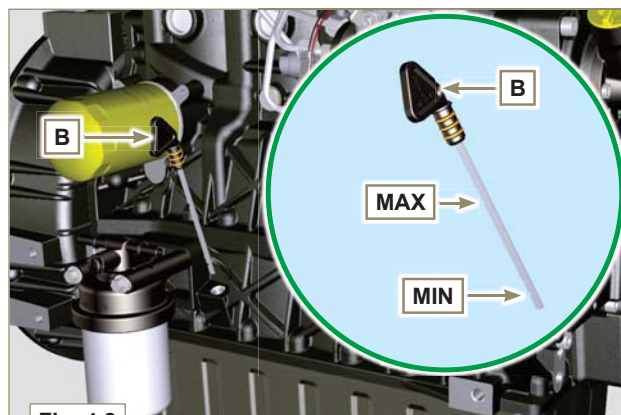

Fig. 4.2

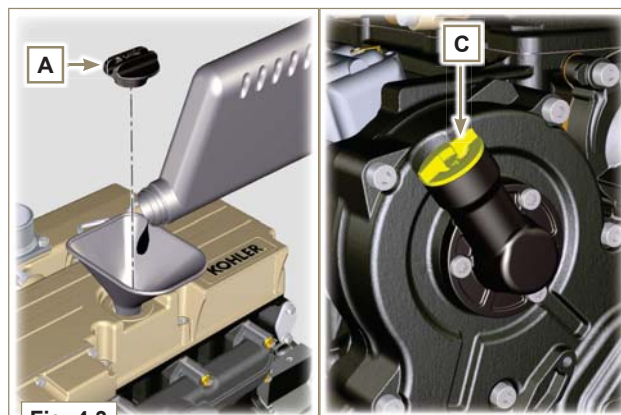

Fig. 4.3

4.5 Fuel filter cartridge check

1 - Gently loosen the water drain plug **A** without removing it.

2 - Spill out the water if present.

3 - Re-tighten the water drain plug **A** as soon as the fuel spills.



Fig. 4.4



Danger

Disconnect the negative wire (-) from the battery to avoid accidental engine starting.

For safety precautions see [Cap. 2](#).

4.6 Check of the radiator heat-exchanger surface

NOTE: Component not necessarily supplied by KOHLER.



Important

- Wear safety goggles when using compressed air.
- The radiator heat-exchange surface must be cleaned on both sides.

- 1 - Check the radiator heat-exchange surface **D**.
- 2 - Clean the surface with a brush soaked in special detergent if it is clogged.

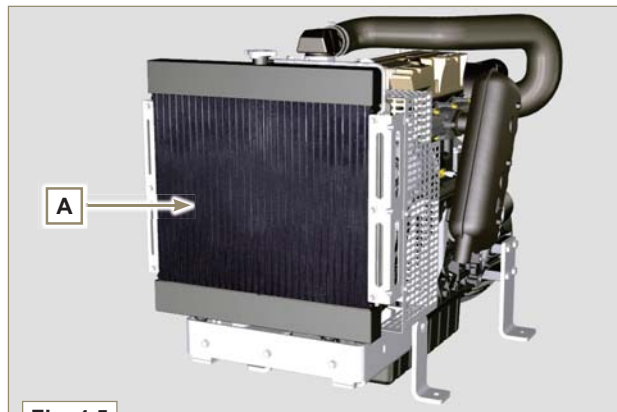

Fig. 4.5

4.7 Rubber hoses check

The check is carried out by exerting a slight deflection or bending along the pipe and near the hose clamps.

Components must be replaced if they have clear signs of cracks, tears, cuts, leaks and do not retain a certain degree of elasticity.

- 1 - Check that the:
 - fuel system hoses **A** are intact.



Important

- If they are damaged contact an authorized KOHLER workshop.

- Hoses for the cooling circuit **B1** and **B2**.
To access the control of the cooling hoses **B1** unscrew the four screws **E** and remove the safe guard **F**.
If necessary, replace [Par. 5.7](#).
- Vent system pipes **C**.
- Air system ducts **D**.
Replace them if necessary [Par. 5.9](#).

When the control is finished the safe guard **F** mount and tighten the four screws **E**.

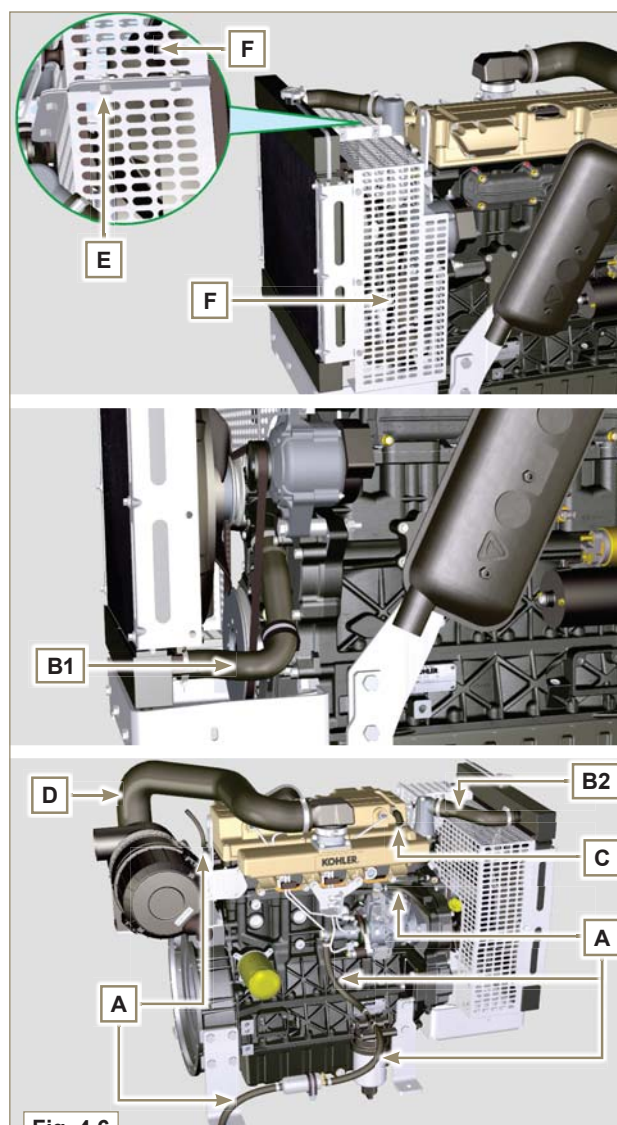

Fig. 4.6

4.8 Alternator belt tension check

- 1 - Check the belt condition **A**.
- 2 - Replace the belt if it is worn or the period of 24 months is elapsed ([Par. 5.6](#)).
- 3 - Check that at point **p** the tension value is between **70** and **75 Hz** for V-belt of 9 mm and **80** and **85 Hz** for V-belt of 17 mm (**Fig. 4.8**) (**H**).
By the tool **F** (DENSO BTG-2) shown in the picture (or a similar one) it is possible to check the corresponding value in Newton, (which should be) included between **200** and **230 N** for V-belt of 9 mm and **350** and **450 N** for V-belt of 17 mm (**Fig. 4.8**) (**H**).

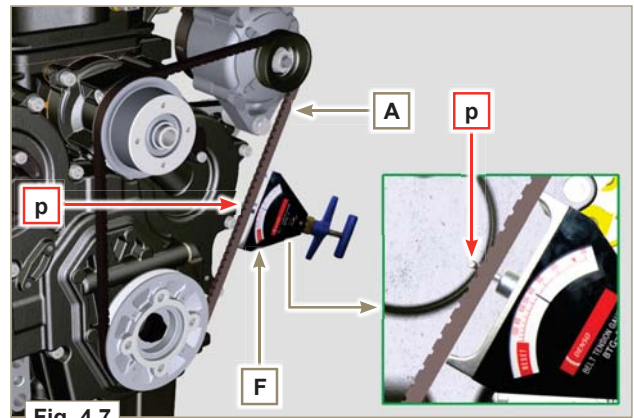

Fig. 4.7

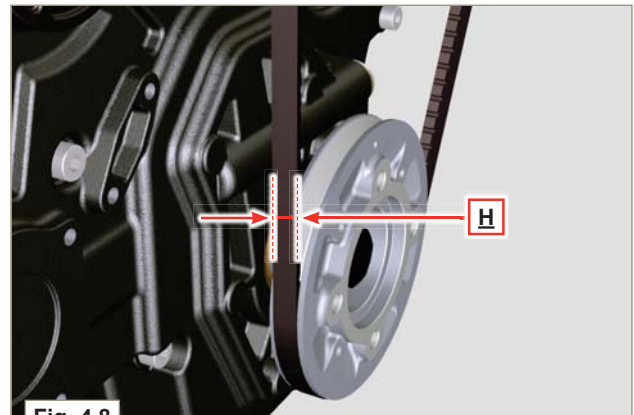

Fig. 4.8

- 4 - If no tools are available, to check correctly the tension apply a force in the direction of arrow **G** of about 10 kg on the point **p**, the belt **A** flexion must be lower than 10 mm. ([Par. 7.1](#)).

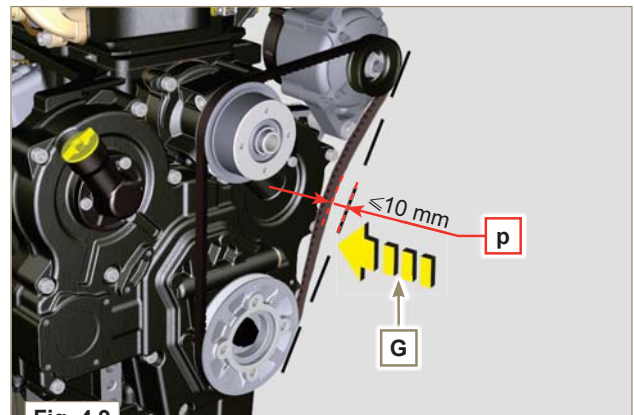

Fig. 4.9

4.9 Check on cooling circuit - Air bleeding

- 1 - Start the engine without the radiator cap **A** or the expansion tank (C) cap **B** (Fig. 4.11).
- 2 - Keep it running at idle speed until the cooling liquid level goes down and becomes steady (the waiting times varies according to the ambient temperature).
- 3 - Stop the engine and allow it to cool.
- 4 - If there is an expansion tank (C) top liquid up to the mark **MAX** (Fig. 4.11).
- 5 - Without expansion tank top liquid up until the pipes inside the radiator are covered by 5 mm. Do not overfill the radiator, but leave room for the fuel to expand.
- 6 - Tighten the radiator cap **A** or the expansion tank (C) cap **B**.



Warning

- Before starting make sure that the radiator cap and expansion tank cap, if present, are installed correctly to avoid spillage of liquid or vapour at high temperatures.
- 7 - After a few hours of operation stop the engine and allow it to cool.
Check and top up the coolant liquid.

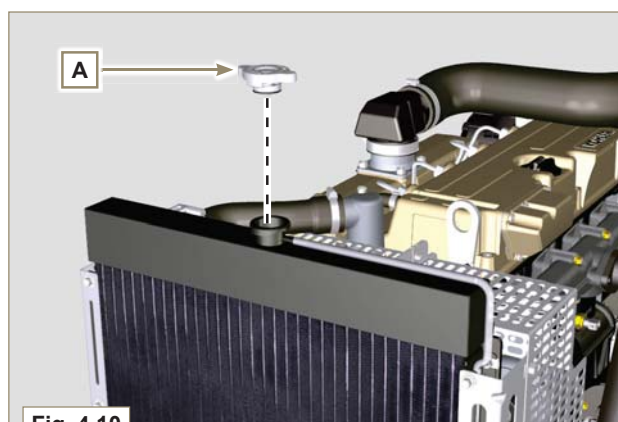

Fig. 4.10

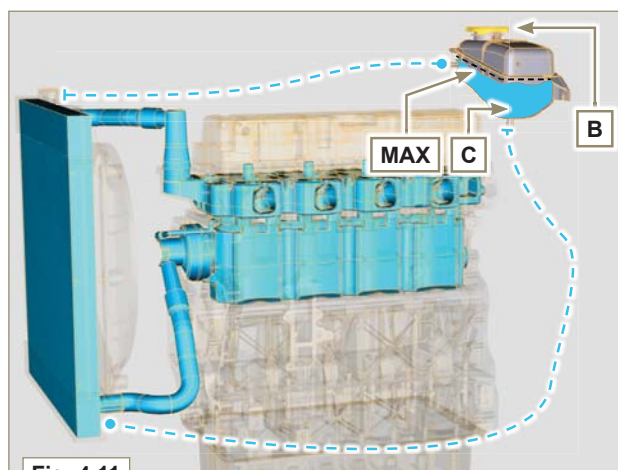

Fig. 4.11

4.10 Air filter check

NOTE: Component not necessarily supplied by KOHLER.

- 1 - Release the two hooks **D** of the cover **A**.
- 2 - Remove the cartridges **B**.
- 3 - Clean the inside components **A** and **C** with a damp cloth.
- 4 - **Do not use compressed air**, repeatedly tap the front side **E** on a flat surface.



Important

- When the cartridge **G** is dirty, **do not clean it but replace cartridges B and G**.
- 5 - Reinstall:
 - cartridges **G** and **B**.
 - the cover **A** checking the right tightness of hooks **D**.

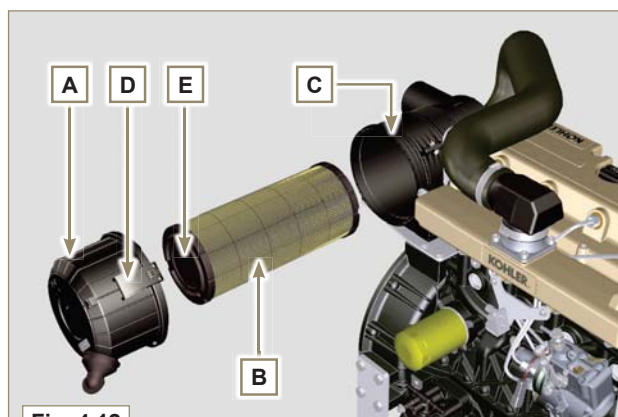

Fig. 4.12

4.11 Product preservation



Important

- If the engines are not to be used for 6 months, they must be protected carrying out the operations described in Engine storage (up to 6 months) (**Par. 4.12**).
- If the engine is still not in use after the first 6 months, it is necessary to carry out a further measure to extend the protection period (more than 6 months) (**Par. 4.13**).
- If the engine is not to be used for extensive periods, the protective treatment must be repeated within 24 months from the last measure.

4.12 Engine storage (up to 6 months)

Before storing the engine check that:

- The environments are not humid or exposed to bad weather. Cover the engine with a proper protective sheet against dampness and atmospheric agents.
- The place is not near electric power lines.
- Avoid storing the engine in direct contact with the ground.

4.13 Engine storage (over 6 months)

Follow the steps described in Par. 4.12.

- 1 - Pour in the engine housing protective oil up to the maximum level.
- 2 - Refuel with fuel additives for long storage.
- 3 - With expansion tank:
make sure that the coolant is up to the **maximum** level.
- 4 - Without expansion tank:
Top liquid up until the pipes inside the radiator are covered by about 5 mm.
Do not overfill the radiator, but leave room for the fuel to expand.
- 5 - Start the engine and keep it idle at minimum speed for 2 minutes.
- 6 - Bring the engine to 3/4 of the **maximum** speed for 5÷10 minutes.
- 7 - Turn off the engine.
- 8 - Empty out completely the fuel tank.
- 9 - Spray SAE 10W-40 on the exhaust and intake manifolds.
- 10 - Seal the exhaust and intake ducts to prevent foreign bodies from entering.
- 11 - Thoroughly clean all external parts of the engine.
When washing the engine, if pressure or steam washing devices are used, avoid turning the high-pressure jet to electrical components, cable connection and sealing rings (oil seals).

With a high-pressure flushing or steam it is important to keep a minimum distance of at least 200 mm between the surface to be washed and the nozzle.
Avoid absolutely parts such as alternator, starter motor and control unit.

12 - Treat non-painted parts with protective products.

13 - Loosen the alternator belt [Par. 4.8](#).

If the engine protection is performed according to the suggestions indicated no corrosion damage will be found.

4.14 Engine starting after storage

- 1 - Remove the protective sheet.
- 2 - Use a cloth soaked in degreasing product to remove the protective treatment from the external parts.
- 3 - Inject lubricating oil (no more than 2 cm³) into the intake ducts.
- 4 - Adjust the alternator belt tension ([Par. 7.1](#)).
- 5 - Refill the tank with fresh fuel.



Warning

- Over time, lubricants and filters lose their properties, so it is important considering whether they need replacing, also based on the criteria described in [Tab. 4.2](#).
- 6 - Make sure that the oil and the coolant are up to the **maximum** level.
 - 7 - Start the engine and keep it idle at minimum speed for a two about minutes.
 - 8 - Bring the engine to 3/4 of the **maximum** speed for 5÷10 minutes.
 - 9 - Stop the engine while the oil is still hot ([Par. 5.1](#)), discharge the protective oil in a suitable container.
 - 10 - Pour new oil ([Par. 3.5](#)) up to the **maximum** level.
 - 11 - Replace the filters (air, oil, fuel) with original spare parts.
 - 12 - Empty the cooling circuit completely and pour in the new coolant up to the **maximum** level ([Par. 3.6](#)).

5.1 Engine oil replacement



Important

- Place engine on level surface to ensure accurate measurement of oil level.

NOTE: Perform this operation with warm engine, to get a better fluidity of the oil and get a full discharge of oil and impurities contained in it.

- 1 - Loosen the oil filler cap **A** (Fig. 5.1).
 - 2 - Remove the oil dipstick **B**.
 - 3 - Remove the oil drain plug **D** and the gasket **E** (the oil drain plug is on both sides of the oil sump).
 - 4 - Drain oil in an appropriate container.
(For the exhausted oil disposal, refer to [Par. 5.10 DISPOSAL](#) and [SCRAPPING](#)).
 - 5 - Replace gasket **E**.
 - 6 - Tighten the drain oil plug **D** (tightening torque at 50 Nm).
 - 7 - Adding the type and amount of oil recommended ([Tab. 1.1](#) and [Tab. 1.2](#)).
 - 8 - If the plug **A** is not accessible, use the oil filler cap **C**.
- Do not exceed the **MAX** level.

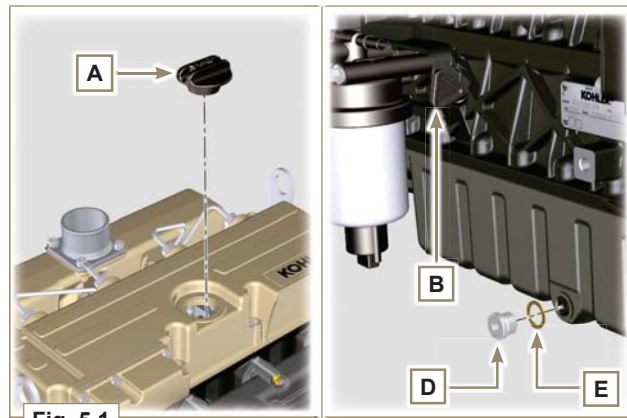

Fig. 5.1

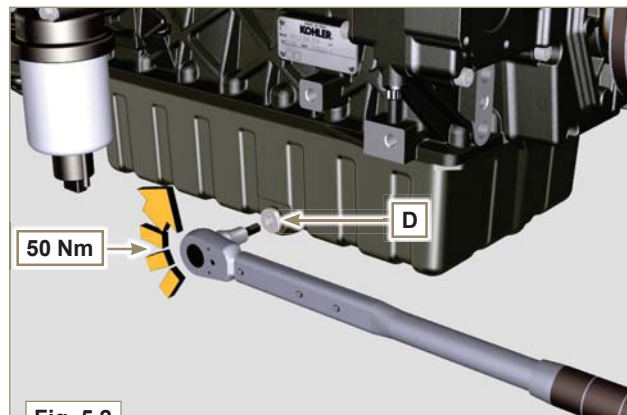

Fig. 5.2

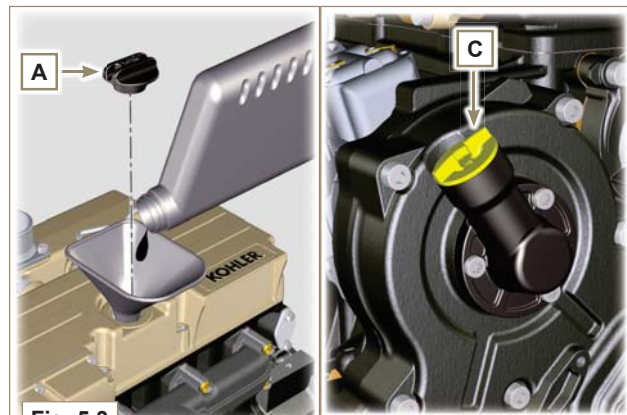

Fig. 5.3

- 9 - Fit and remove the oil dipstick **B** to check the level. Pour in fluid until reaching the **MAX** level mark.
- 10 - Upon completion, reinstall the oil dipstick **B** correctly.
- 11 - Tighten the cap **A** or **C**.

NOTE: See the [Par. 6.1](#) for the various configurations of the oil dipstick.

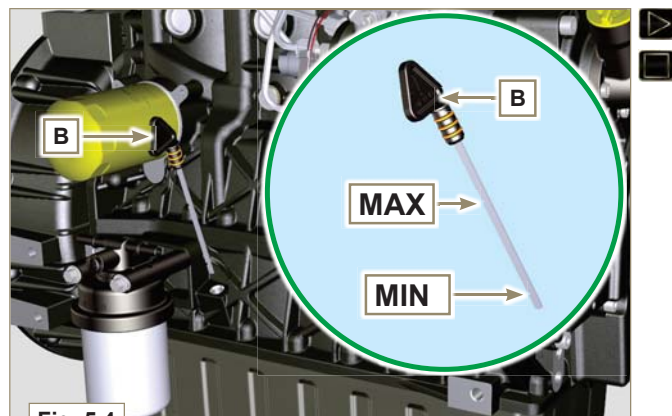

Fig. 5.4

5.2 Coolant replacement

1 - Loosen the plug **A** carefully (pressure circuit) (fig. 5.5).

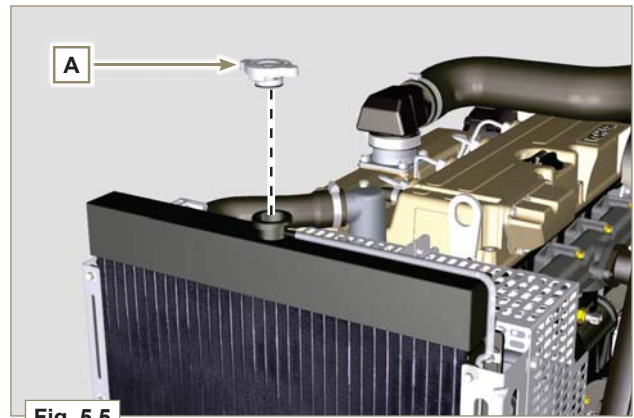

Fig. 5.5

2 - Unscrew the screws **B** and remove the safe guard **C**.

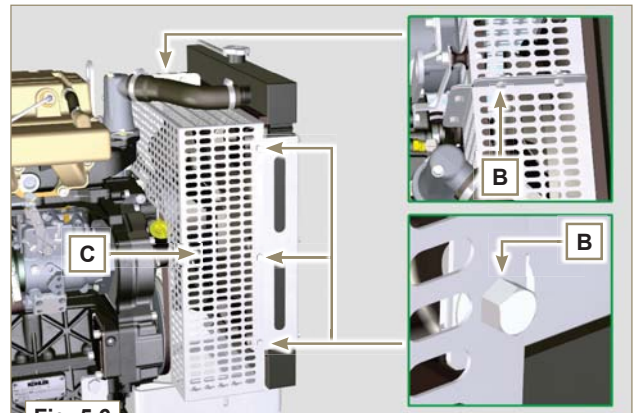

Fig. 5.6

3 - Unscrew the cap **E** and drain liquid coolant from radiator in to appropriate tank.

4 - Loosen the cap **G** to allow draining all liquid of the system in the engine block.

5 - Tighten the cap **G**, replacing the copper gasket. (Tightening torque of **50 Nm**).

6 - Tighten the cap **E**, replacing the copper gasket **D**.

7 - Refill the radiator with coolant composed of: 50% ANTIFREEZE and 50% water.

8 - Top liquid up until the pipes inside the radiator are covered by about 5 mm.

9 - For engines equipped with separate expansion tank, pour in fluid until reaching the max level mark.

10 - Bleeding the cooling circuit as indicated in the [Par. 4.9](#).

11 - Tighten the radiator cap **A**.

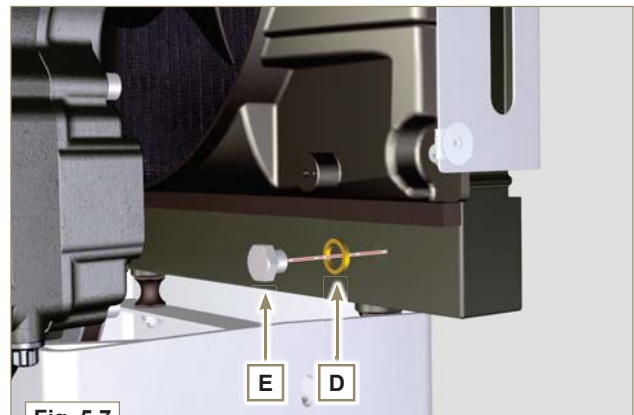

Fig. 5.7

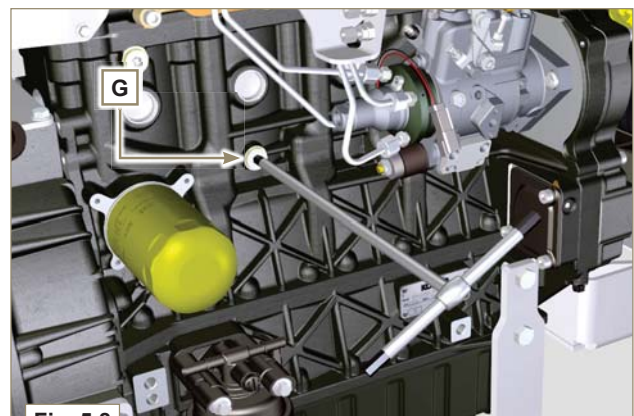

Fig. 5.8



Warning

Oil filter cartridge replacement (Par. 5.3) and fuel filter replacement (Par. 5.4)

In case of low use replace it every year.
For disposal of oil filter cartridge and fuel filter refer to [Par. 5.10 DISPOSAL](#) and [SCRAPPING](#).

5.3 Oil filter cartridge replacement

1 - Unscrew the oil filter **A** with appropriate wrench.

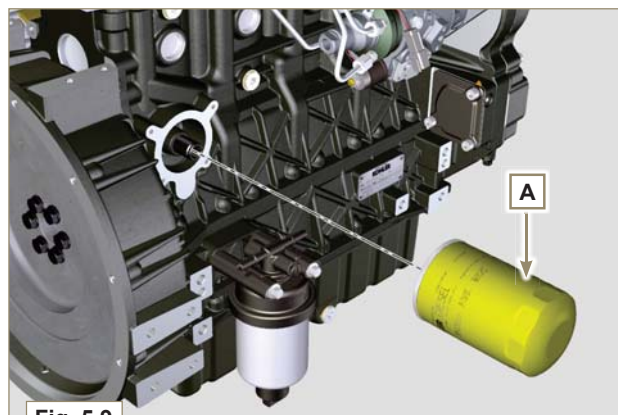

Fig. 5.9

2 - Assembly and tighten the new oil filter cartridge **A** tightening it with torque wrench **B** (torque to 20 Nm).

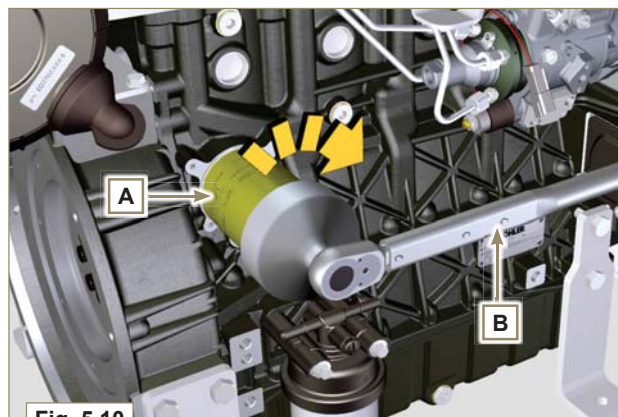

Fig. 5.10

5.4 Fuel filter cartridge replacement

1 - Unscrew the filter cartridge **A** from the holder **B**.

2 - Unscrew the fuel water sensor **D**.

3 - Replace the gasket **C**.

4 - Lubricate the gasket **E**.

5 - Screw the new filter cartridge **A**.

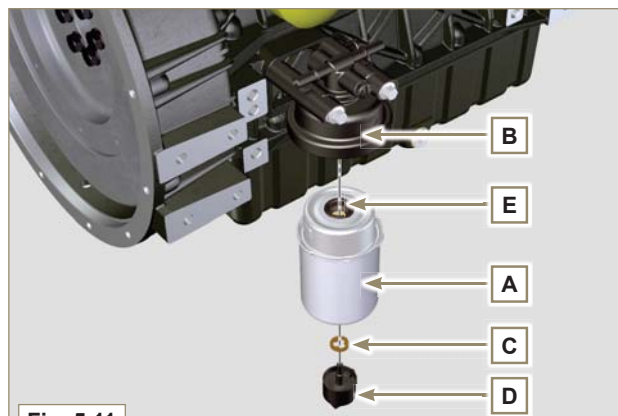

Fig. 5.11

5.5 Bleeding the fuel system

- 1 - Turn the key on the control panel to the **ON** position.
The electric pump **C** sends fuel to the filter and then the injection pump **D**.
- 2 - Procure a suitable container to collect the fuel.
- 3 - Loosen the air bleeding screw **A** on fuel filter bracket **B**.
The air inside the circuit and the filter will begin to escape from the screw **A**.
- 4 - Tighten the bleeding screw **A** when the fuel begins to flow.

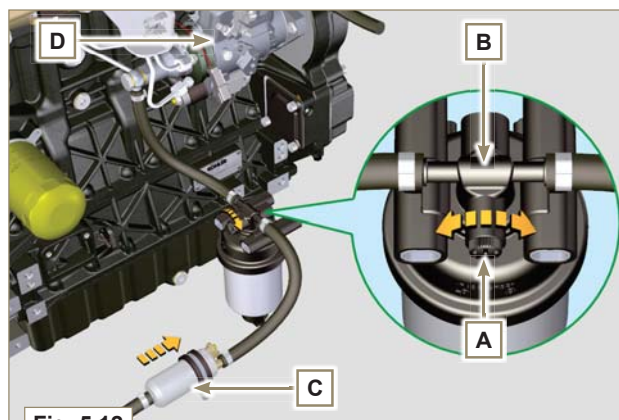

Fig. 5.12



Danger

Disconnect the negative wire (-) from the battery to avoid accidental engine starting.

5.6 Alternator belt replacement

- 1 - Loosen the fastening bolts **A** and **B**.
- 2 - Push the alternator in the direction of the arrow **E**.
- 3 - Replace the belt **C**.
- 4 - Pull the alternator outwards (in the direction of the arrow **F**), to tension the belt.
- 5 - Tension the belt by tightening the bolts **A** and **B**.
- 6 - Manually tighten the screw **B** until screw end.
- 7 - Tighten the bolts **A** and **B** in **sequence** with a torque wrench **D** (tightening torque of **40 Nm**).
- 8 - Check tensioning as described in the [Par. 4.8](#) (point 3).
- 9 - In the event that the belt tension is beyond the values described repeat all operations **1**, **4**, **5** and **6**.

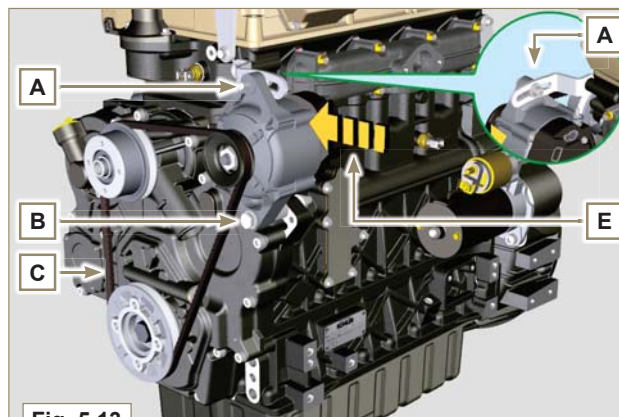

Fig. 5.13

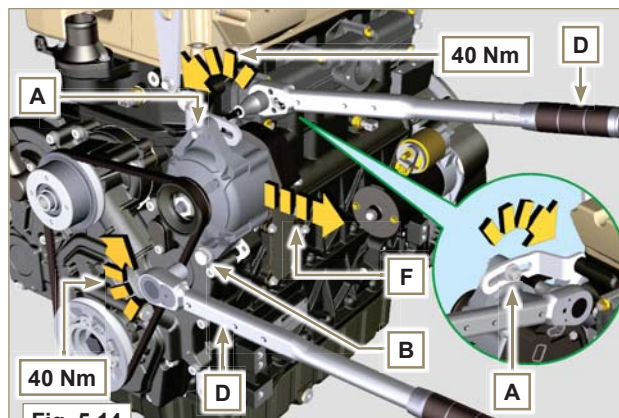

Fig. 5.14

EN

5.7 Cooling circuit hoses replacement

NOTE: Component not necessarily supplied by KOHLER.

1 - Empty the cooling circuit ([Par. 5.2](#) points from 1 to 10).

NOTE: The following operations apply to all cooling circuit hoses.

- 2 - Loosen the hoses clamps **B**.
- 3 - Remove the hoses **C**.
- 4 - Fit the new hoses **C** and tighten the clamps **B**.
- 5 - Tighten the cap **A** on the radiator ([Fig. 5.5](#)).



Warning

- Make sure that clamps are tightened correctly, to avoid coolant leakages.



Important

- The replacement hose **H** must be carried out by authorized KOHLER workshop.

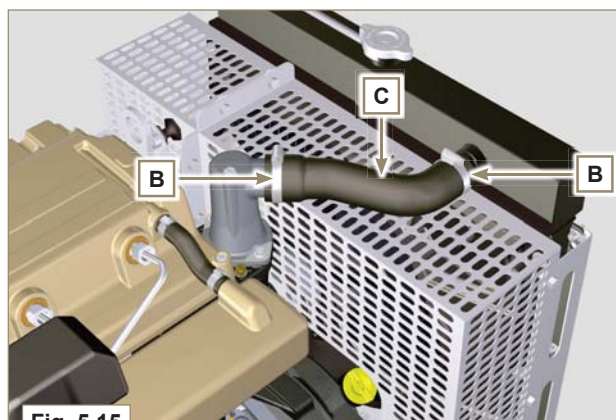

Fig. 5.15

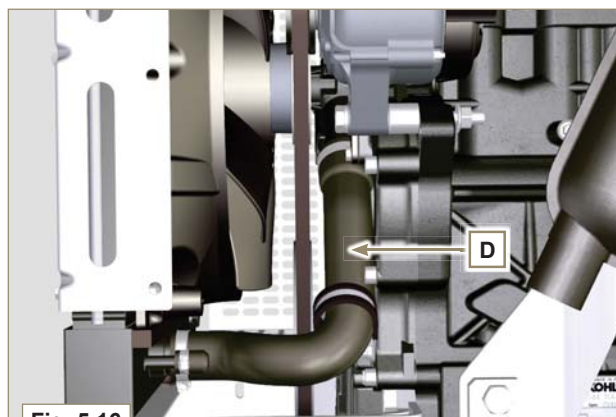

Fig. 5.16

5.8 Air filter cartridge replacement

NOTE: Component not necessarily supplied by KOHLER.

- 1 - Release the two fastenings **F** of the cover **A**.
- 2 - Remove the cartridge **B**.
- 3 - Reinstall:
 - the new cartridges **B**.
 - the cover **A** checking the right tightness of fastenings **F**.

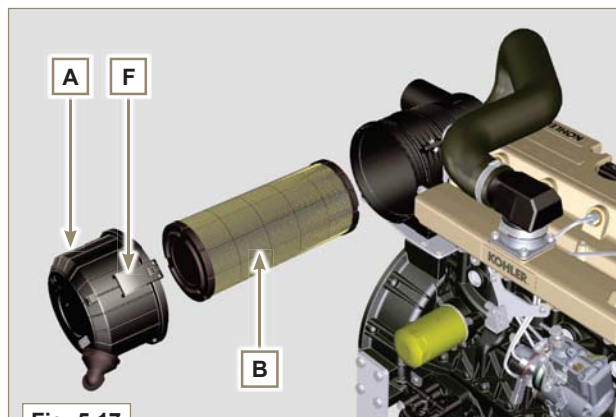

Fig. 5.17

5.9 Air intake hoses replacement

NOTE: Component not necessarily supplied by KOHLER.



Danger

- If an electric fan is installed, do not approach a hot engine since the fan itself could start up even when the engine is off.

- 1 - Loosen the hose clamp **A** and remove pipe **B**.
- 2 - Fit the new pipe **B** and fasten the new clamps **A**.

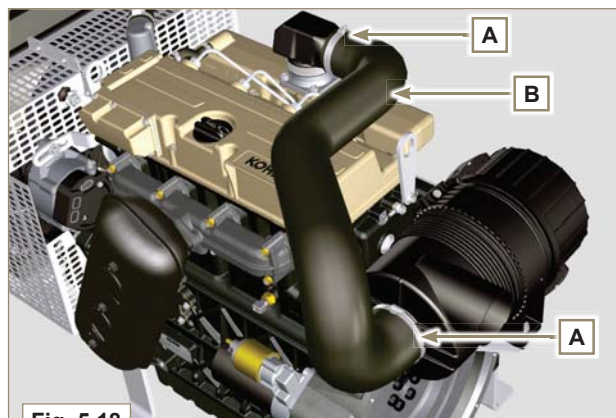

Fig. 5.18

5.10 Disposal and scrapping

- In case of scrapping, the engine shall be disposed of in appropriate dumps, in conformity with the law in force.
- Before scrapping, it is necessary to separate the rubber or plastic parts.
- The parts only composed of plastic material, aluminium and steel can be recycled if collected by the appropriate centres.
- For collection of waste oil you must contact the "Waste Oil Compulsory Association".
- Waste oil must properly be recycled and disposed of in the correct way to safeguard the environment. According to the laws in force, it is classified as hazardous waste, therefore it must be collected by the appropriate centres.

6.1 Oil dipstick on cylinder head

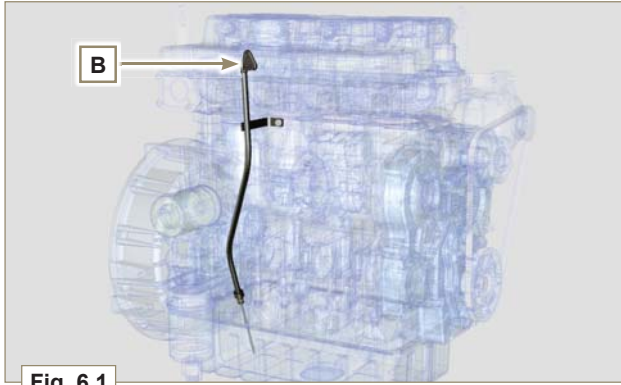

Fig. 6.1

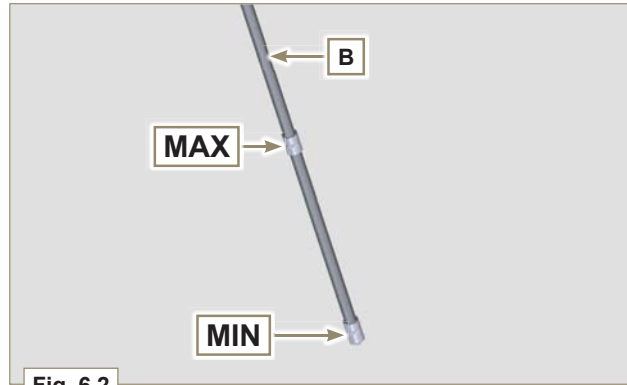

Fig. 6.2

6.2 Electric pump

1 - Turn the key on control panel to the **ON** position.

NOTE: The electric pump **A** sends fuel to the filter and then to the injection pump.

2 - For bleeding procedure see [Par. 5.5](#).

3 - Turn the key to **OFF** position.

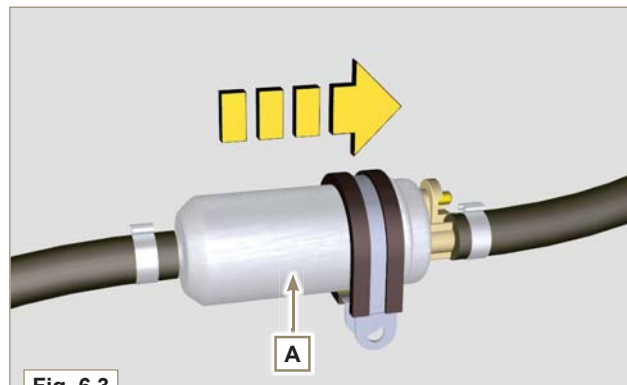

Fig. 6.3

6.3 Heater (replacement)

- 1 - Loosen the clamp **A** and remove the sleeve **N**.
- 2 - Unscrew the nut **B** and relevant washer.
- 3 - Remove the screws **C** and relevant washers **D** and remove the earth cable **E**.
- 4 - Remove the flange **F**.
- 5 - Remove the heater **L** and the relevant gaskets **G**.

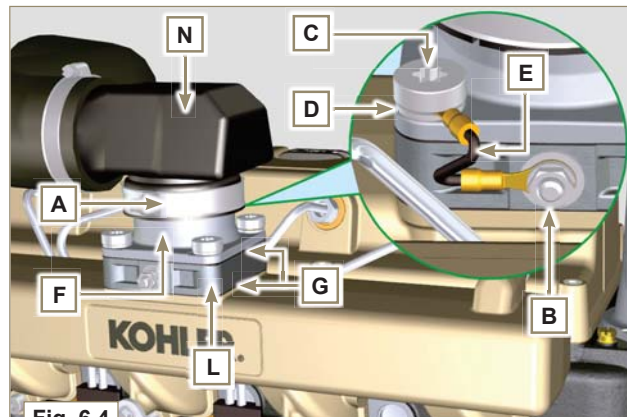

Fig. 6.4

- 6 - In sequence, fit manifold **M** with the gasket **G**, the new heater **L**, the second gasket **G**, the flange **F**, the washers **D**, the screws **C** and the cable **E**.
- 7 - Secure the flange **F** with the screws **C** (torque at **25Nm**) (**Fig. 6.4**).
- 8 - Secure the earth cable **E** with the nut **B** and the relevant washer on the heater **L**.
- 9 - Fit the sleeve **N** on the radiator **P** and secure the clamp **A**.

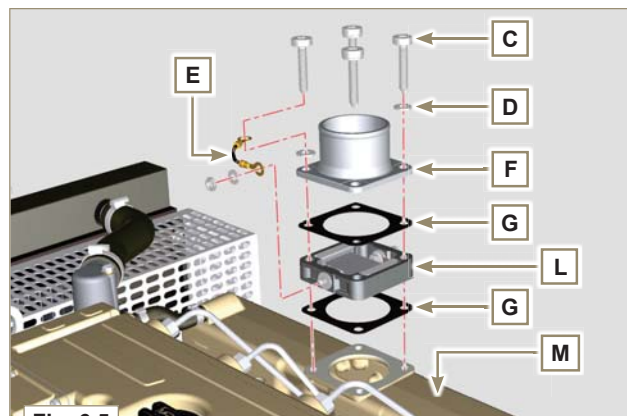

Fig. 6.5

6.4 Remote oil filter (cartridge replacement)

- 1 - Unscrew and remove the cartridge **A** with the relevant spanner.
- 2 - Lubricate the gasket and screw on the new cartridge **A** with the relevant spanner.

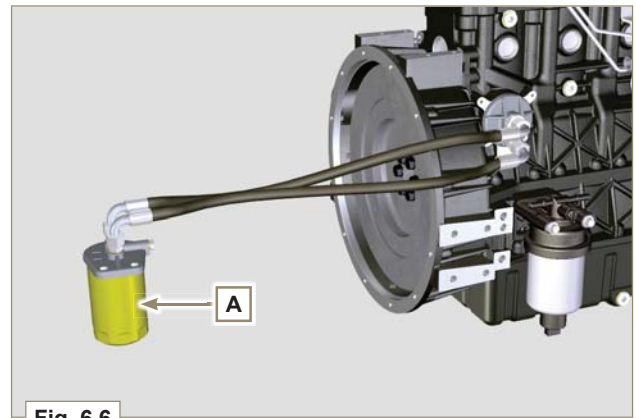

Fig. 6.6

6.5 Balancer shafts



Important

- For the versions equipped with 2 balancer shafts, one must refer to [Tab. 1.1](#) to find out the right amount of oil to insert.
- In the absence of information on the version in one's possession, refer to the **MAX** level of the oil dipstick in the operations described in [Par. 3.5](#).



Fig. 6.7

6.6 3rd PTO



Important

- On some versions of this engine can be the provision for the 3rd PTO **A**.
- Contact a **KOHLER** authorised workshop for installation.

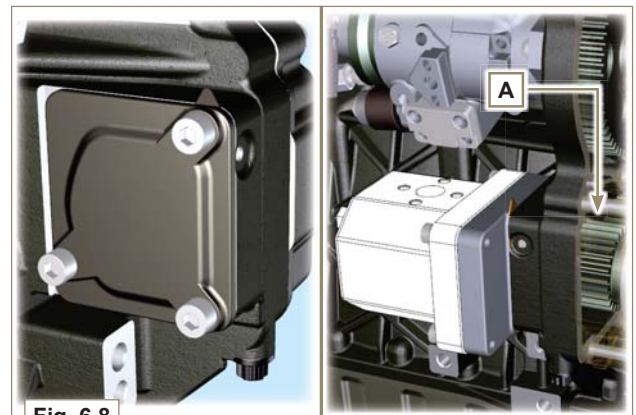

Fig. 6.8

6.7 4th PTO



Important

- On some versions of this engine can be the provision for the 4th PTO **A**.
- Contact a **KOHLER** authorised workshop for installation.

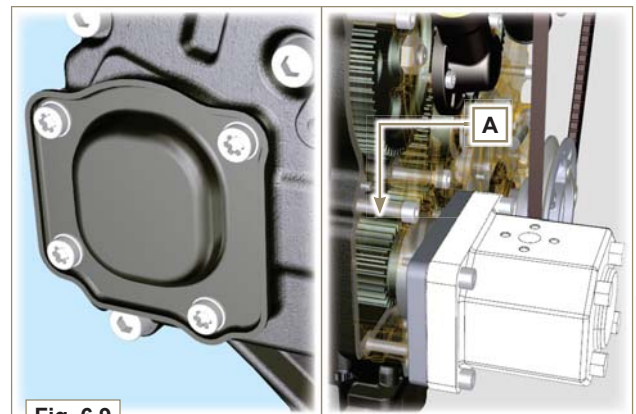

Fig. 6.9

7.1 Alternator belt tension adjustment

- 1 - Check the belt condition **A**.
- 2 - Loosen the fastening bolts **B** and **C**.
- 3 - Pull the alternator outwards (in direction of the arrow **D**), to tension the belt.
- 4 - Tension the belt tightening the bolts **B** and **C**.
- 5 - Tighten bolts **B** and **C** in sequence with a torque wrench **E** (tightening torque of **40 Nm**).

- 6 - Check that at point **p** the tension value is between **70** and **75 Hz** for V-belt of 9 mm and **80** and **85 Hz** for V-belt of 17 mm (**Fig. 7.2**) (**H**).

By the tool **F** (DENSO BTG-2) shown in the picture (or a similar one) it is possible to check the corresponding value in Newton, (which should be) included between **200** and **230 N** for V-belt of 9 mm and **350** and **450 N** for V-belt of 17 mm (**Fig. 7.2**) (**H**).

- 7 - If no tools are available, to check correctly the tension apply a force in the direction of arrow **G** of about 10 kg on the point **p**, the belt **A** flexion must be lower than 10 mm. Let the engine run for 15 min., then let it cool down at ambient temperature ($23^{\circ}\text{C} \pm 5$) and repeat the operations **2**, **3**, **4** and **5** in case the belt tension results out of the above mentioned values.

NOTE: Once the operation has been completed, apply to a **KOHLER** authorized workshop, to check the correct tension.

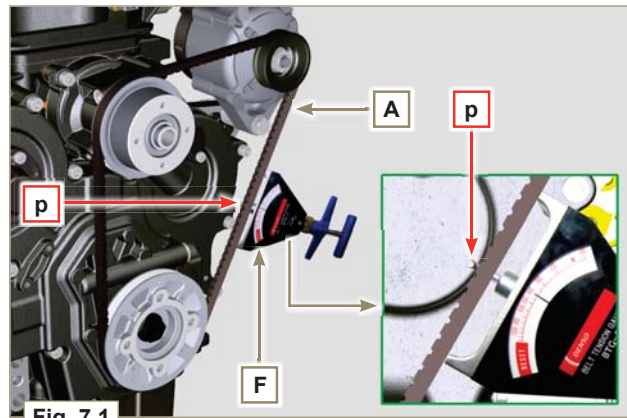

Fig. 7.1

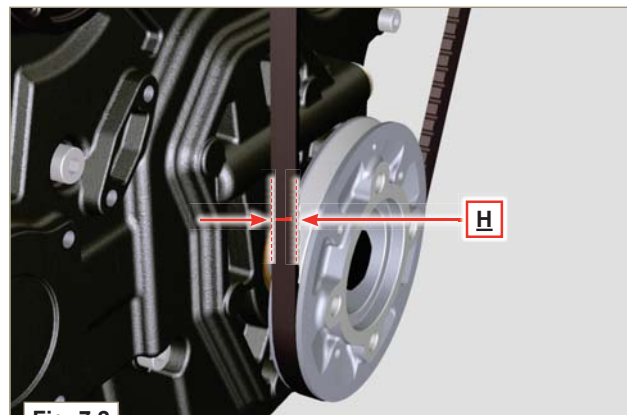

Fig. 7.2

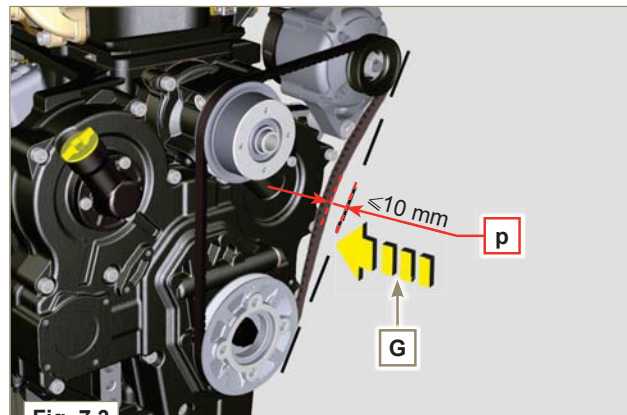

Fig. 7.3

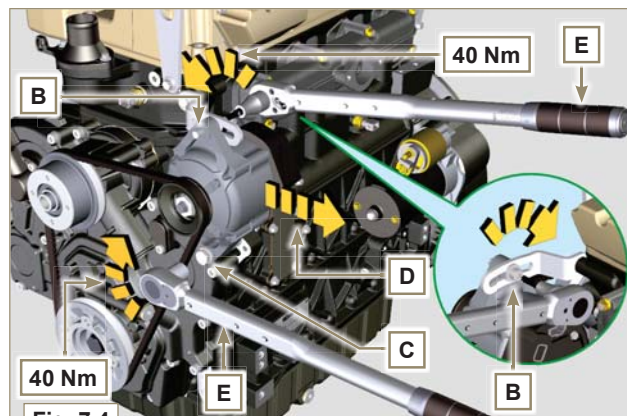

Fig. 7.4

8.1 Useful information about failures

- This chapter contains information about the problems that may appear during engine operation with its causes and trouble shooting **Tab. 8.2**.
- In some cases, you shall turn off the engine immediately to avoid further damage **Tab. 8.1**.

Tab. 8.1

THE ENGINE MUST BE IMMEDIATELY TURNED OFF WHEN:	
1	The engine rpms suddenly increase and decrease
2	A sudden and/or unusual noise is heard
3	The colour of the exhaust fumes suddenly darkens
4	The oil pressure indicator light turns on while running

Tab. 8.2

TROUBLES	POSSIBLE CAUSE	SOLUTION	PAR.
The engine does not start	Sulphated battery terminals	Clean the battery terminals	--
	Battery voltage too low	Recharge the battery or replace it	--
	Low fuel level	Refuel	3.4
	Frozen fuel	Contact KOHLER authorised workshops	--
	Clogged fuel filter	Replace with a new filter	5.4
	Air suction in fuel system	Contact KOHLER authorised workshops	--
	Clogged air filter	Replace with a new filter	5.8
	Clogged pipes	Contact KOHLER authorised workshops	--
	Burnt fuse	Replace with a new fuse; if the problem persists, contact KOHLER authorised workshops	--
	Intake or exhaust system clogged	Contact KOHLER authorised workshops	--
Engine starts but stops	Inefficient electrical connections	Clean the electrical contacts; if the problem persists, contact KOHLER authorised workshops	--
	Sulphated battery terminals	Clean the battery terminals	--
	Clogged fuel filter	Replace with a new filter and clean the tank	--
	Clogged fuel pipes	Contact KOHLER authorised workshops	--
RPM instability at idle speed	Clogged fuel pipes	Contact KOHLER authorised workshops	--
Low idle speed	Clogged fuel pipes	Contact KOHLER authorised workshops	--
	Poor quality fuel	Clean the tank and refuel with quality fuel	1.5
Blue smokes	High oil sump level	Replace the engine oil; if the problem persists, contact KOHLER authorised workshops	--
	Clogged air filter	Replace with a new filter	5.8
Excessive fuel consumption	Clogged air filter	Replace with a new filter	5.8
	High sump level	Replace the engine oil; if the problem persists, contact KOHLER authorised workshops	--
Engine lost its initial performance	Clogged air filter	Replace with a new filter	5.4
	Clogged fuel pipes	Contact KOHLER authorised workshops	--
	Cheap fuel	Clean the tank and refuel with quality fuel	--
	High oil sump level	Replace the engine oil; if the problem persists, contact KOHLER authorised workshops	--
Low acceleration	Clogged fuel filter	Replace the fuel filter	5.4
Engine jerking	Clogged fuel pipes	Contact KOHLER authorised workshops	--
Engine overheats	Insufficient coolant level	Fill up to the level	3.6
	High sump level	Replace the engine oil; if the problem persists, contact KOHLER authorised workshops	--
	Clogged radiator	Clean the radiator; if the problem persists, contact KOHLER authorised workshops	--

EN

- In the event that the solutions proposed in **Tab. 8.2** for all problems appeared should not solve them, contact a **KOHLER** authorized workshop.

MANUFACTURER'S WARRANTY COVERAGE

- Your off-road diesel engine emission control system is covered under warranty for a period of five (5) years or 3,000 hours, whichever occurs first, beginning on the date the engine or equipment is delivered to an ultimate purchaser for all constant speed engines with maximum power $19 \leq kW < 37$ and rated speed less than 3,000 rpm, all variable speed engines with maximum power $19 \leq kW < 37$ and all variable or constant speed engines with maximum power greater than 37 kW.
- Your off-road diesel engine emission control system on variable or constant speed engines with maximum power less than 19 KW and constant speed engines with maximum power $19 \leq kW < 37$ and rated speed equal to or greater than 3,000 rpm is covered under warranty for a period of two (2) years or 1,500 hours, whichever occurs first.
- If any emission related part on your engine is defective, the part will be repaired or replaced by Kohler Co.

OWNER'S WARRANTY RESPONSIBILITIES

- As the heavy-duty off-road engine owner, you are responsible for the performance of the required maintenance listed in your Kohler Co. owner's manual.
- Kohler Co. recommends that you retain all receipts covering maintenance on your heavy-duty off-road engine.
- Kohler Co. cannot deny warranty solely for the lack of receipts or for your failure to ensure the performance of all recommended scheduled maintenance.
- As the heavy-duty off-road engine owner, you should however be aware that Kohler Co. may deny you warranty coverage if your heavy-duty off-road engine or emission control related component has failed due to abuse, neglect, improper maintenance or unapproved modifications.
- Your engine is designed to operate on commercial diesel fuel (No. 1 or No. 2 low sulfur or ultra low sulfur diesel fuel) only.
- Use of any other fuel may result in your engine no longer operating in compliance with California's emissions requirements.
- Requirements for emission directive in force in the Californian State.
- You are responsible for initiating the warranty process.
- The Air Resources Board suggests that you present your heavy-duty off-road engine to a Kohler Co. dealer as soon as a problem exists.
- The warranty repairs should be completed by the dealer as expeditiously as possible.
- Please review the document titled, "Kohler Co. Federal and California Emission Control Systems Limited Warranty Off-Road Diesel Engines", for complete details of your heavy-duty off-road engine warranty.
- If you have any questions regarding your warranty rights and responsibilities or the location of the nearest Kohler Co. authorized service location, you should contact Kohler Co. at 1-800-544-2444 or access our website at www.kohlerengines.com.

KOHLER.

Lombardini a.c.l. is a part of Kohler Group.

Lombardini has manufacturing facilities in Italy, Slovakia and India and sales subsidiaries in France, Germany, UK, Spain and Singapore.

Kohler/Lombardini reserves the right to make modifications without prior notice.

www.kohlernewproject.com

www.lombardini.it

EUROPE

Lombardini Srl

Via Cav. del lavoro
A. Lombardini n° 2
42124 Reggio Emilia, Italy
T. +39 0522 38 91
F. +39 0522 389 503

FRANCE

Lombardini France S.a.s.

47 Allée de Riottier
69400 Limas, France
T. +33. 04 74 62 65 00
F. +33. 04 74 62 39 45

USA & CANADA

Kohler Co.

444 Highland Drive,
Kohler - Wisconsin (53044), US
T. +1 920 457 4441
F. +1 920 459 1570

FORM NO.	ED005302--0		
ISSUED	00/00/0000		
REVISED	00	DATE	00/00/0000