

FQMC2X_10DCEN000

TECHNICAL DATA

ANTI-ROLL GYRO STABILIZER

ATTACHMENT TO INSTALLATION AND USE MANUAL

EN

page 3

TD_MC2.X10_DC_EN_R02_06_2022





1.1 - Technical data

MODEL	MC² X10 DC
Rated speed (1)	6000 RPM
Angular momentum (2)	3120 N·m·s
Output torque (3)	10342 N·m
Spool-up time to rated RPM	24 min
Spool-up time to stabilization	20 min
Power absorbed (4)	1200 ÷ 1600 W max
DC Input voltage	12 Vdc
Circuit Breaker	200A
Fuse	200A
Frequency	50-60 Hz
Noise output	< 70 dB
Ambient air temperature	da-10°C a +55°C
Weight (5)	301 kg (663,6 lb)

(1) Rated speed: flywheel speed (RPM: Revolutions per minute).

(2) Angular momentum: it quantifies the torque that is necessary to balance the system in the time unit (Newtons meter second).

(3) Output torque: torque generated by the rotor at rated speed (Newtons per meter).

(4) Sea state dependent.

(5) Weight with control unit, excluding optional base plate accessory, standard or custom.



1.2 Dimensions

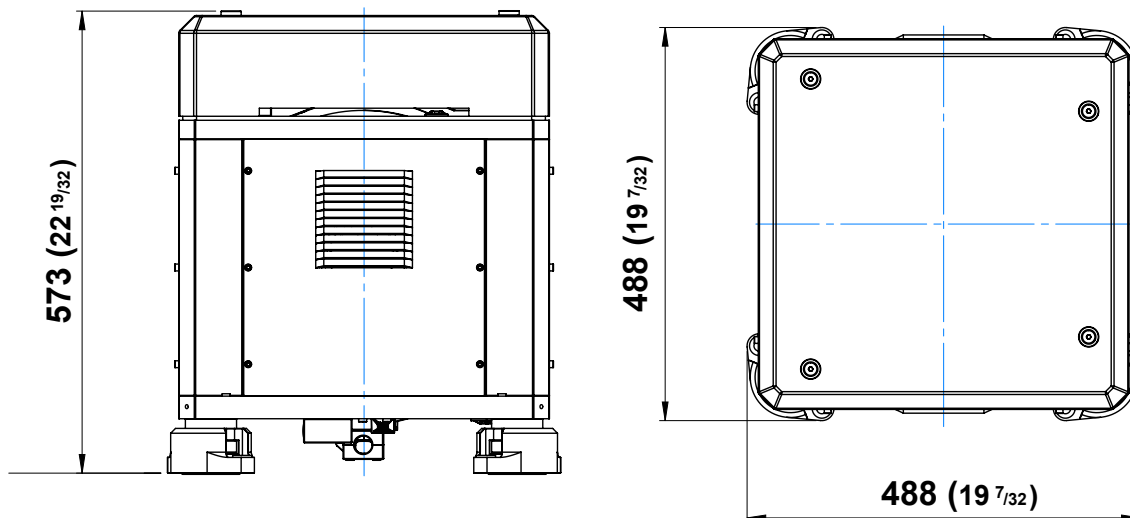

1.3 Dimensions with base plate (optional)

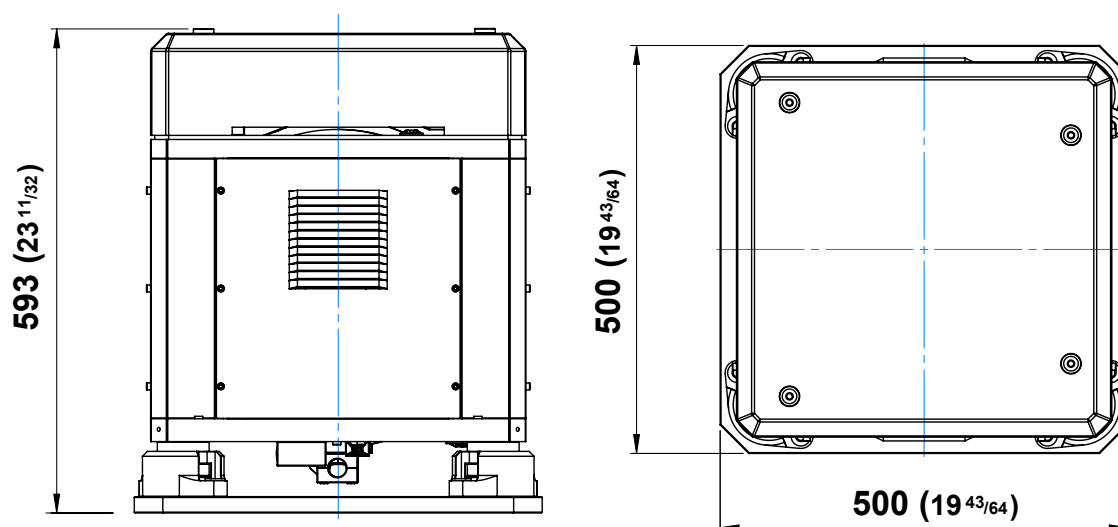



1.4 - Preliminary technical checks

Before proceeding to the installation, it is essential to make sure that the position chosen and the boat structure can withstand and enable the transfer of the loads generated by the gyroscope on the hull.

Load generated by MC²X13

To calculate the structure sizing load use a safety factor (R = 3)

MC²X10_DC

$$10342 \text{ N}\cdot\text{m} \times 3 = 31026 \text{ N}\cdot\text{m}$$

(1Kg = 9,81 N)

The supporting base must be properly dimensioned in order to withstand the declared stabilizing torque (Nm).

By sharing the total stabilizing torque on the three directions for each fixing screw (8 screws), the following torque will result on each dimension:

- Fz: 31 kN
- Fx: 39 kN
- Fy: 34 kN

These forces are to be considered as acting simultaneously.

They do not include the tensions introduced by marine motions during navigation.

If the installer do not able to guarantee that the boat structure is able to withstand and transfer the loads in the hull generated by the gyroscope, a qualified technician or a naval engineer should intervene in order to carry out a suitable structural analysis on site.

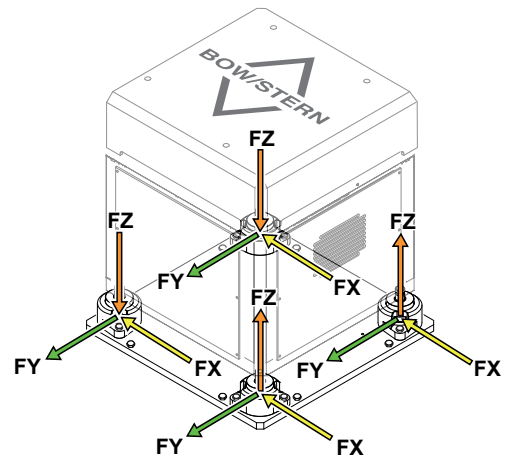
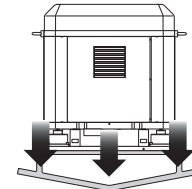

1.5 - General instructions and precautions

The weight to be considered for lifting the is:

$$\text{MC}^2\text{X10_DC} = 301 \text{ kg (663,6 lb)}$$



1.6 - Drilling Template

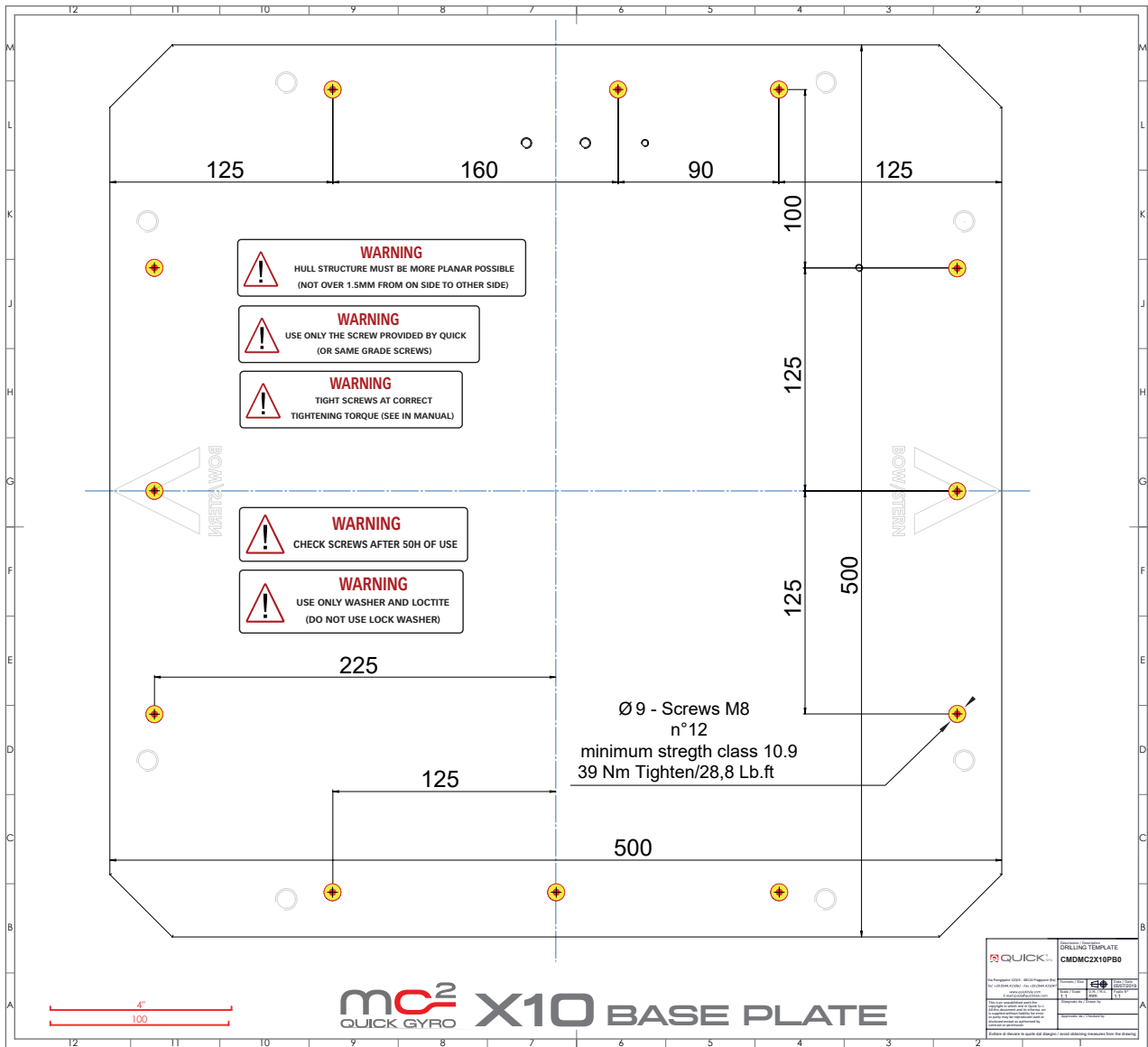



1.6 - Drilling Template

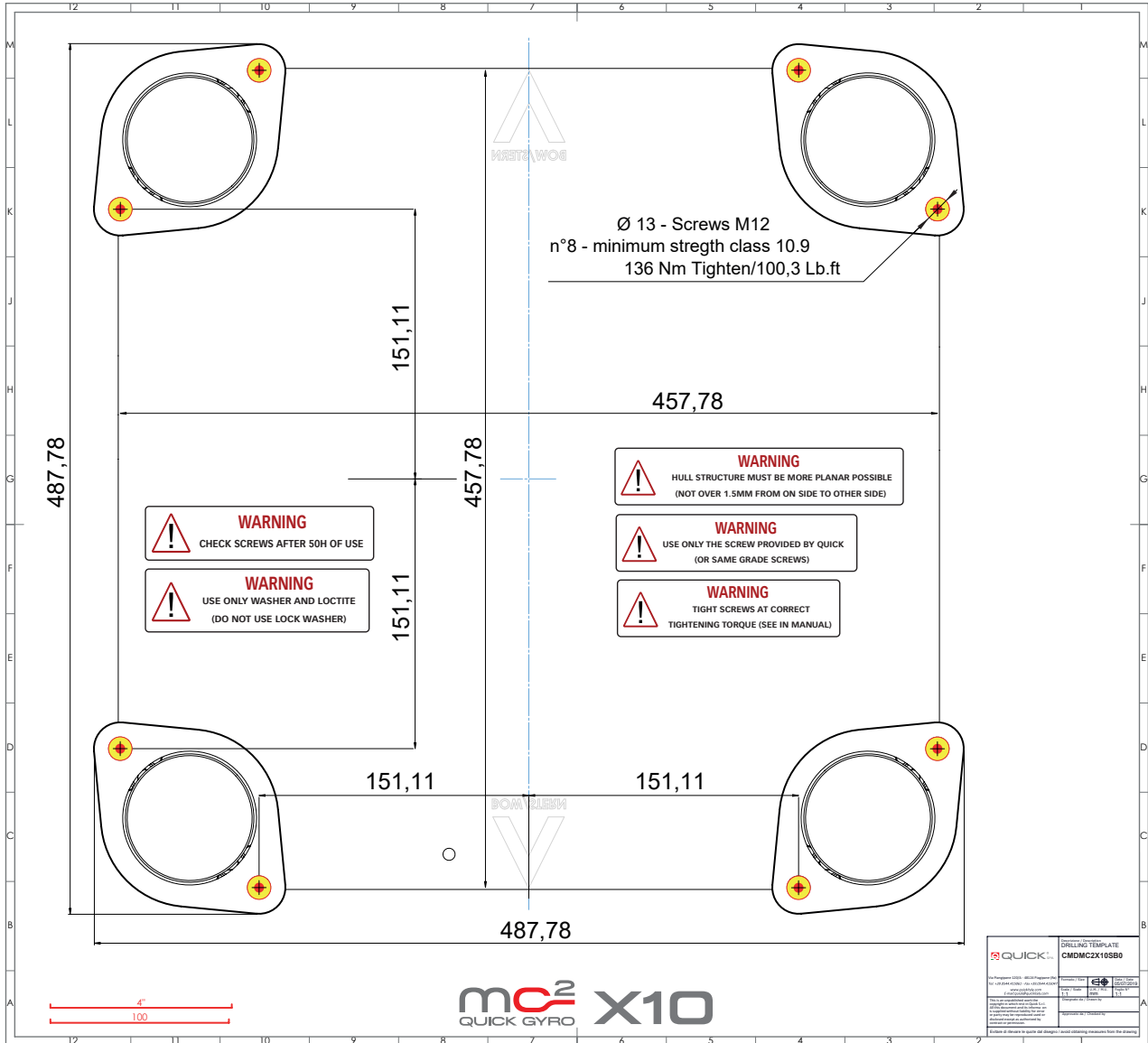

mc²
QUICK GYRO **X10 DC**

REV 002A **CE UK**
CA

JUNE 06/2022

CTDX10DCEN00

TECHNICAL DATA

ANTI-ROLL GYRO STABILIZERS

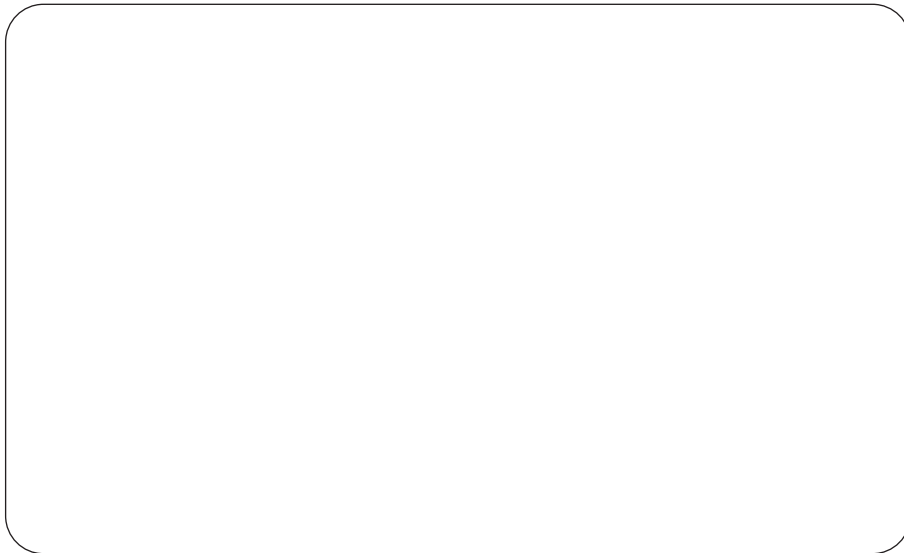

Product code and serial number

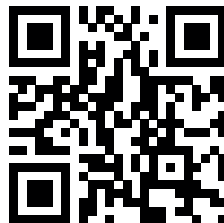

*ALTRE LINGUE DISPONIBILI SCANSIONANDO IL CODICE QR
*OTHER LANGUAGES AVAILABLE BY SCANNING THE QR CODE
*OTROS IDIOMAS DISPONIBLES ESCANEANDO EL CÓDIGO QR
*AUTRES LANGUES DISPONIBLES EN SCANNANT LE CODE QR
*ANDERE SPRACHEN SIND DURCH SCANNEN DES QR-CODES
*OUTROS IDIOMAS DISPONÍVEIS, DIGITALIZANDO O CÓDIGO QR
QRコードをスキャンして利用できる他の言語。

 **QUICK**[®] SPA

QUICK[®] S.p.A. - Via Piangipane, 120/A - 48124 Piangipane (RAVENNA) - ITALY
Tel. +39.0544.415061 - Fax +39.0544.415047 - www.quickitaly.com - quick@quickitaly.com