

UNDERCOUNTER DISHWASHERS  
FP SERIES



HOBART UK,  
SOUTHGATE WAY,  
ORTON SOUTHGATE,  
PETERBOROUGH.  
PE2 6GN  
0844 888 7777

www.hobartuk.com

Undercounter Dishwasher with Vaporinse

FPW-10B

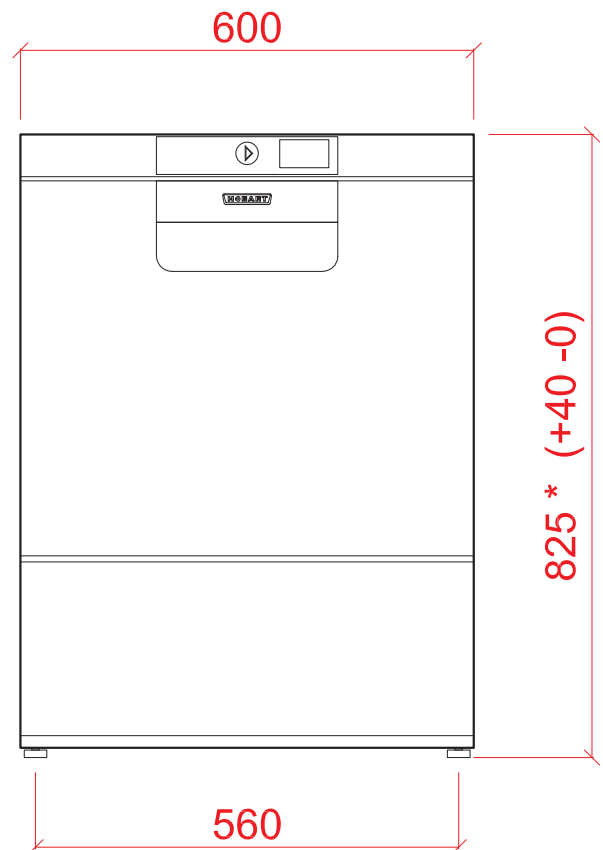
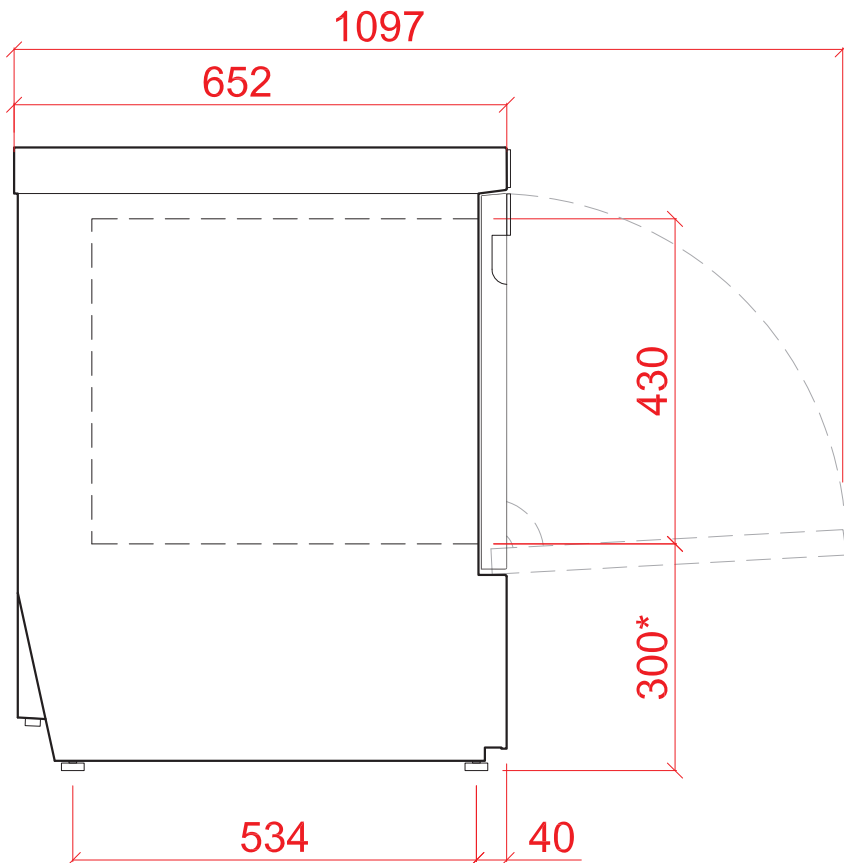
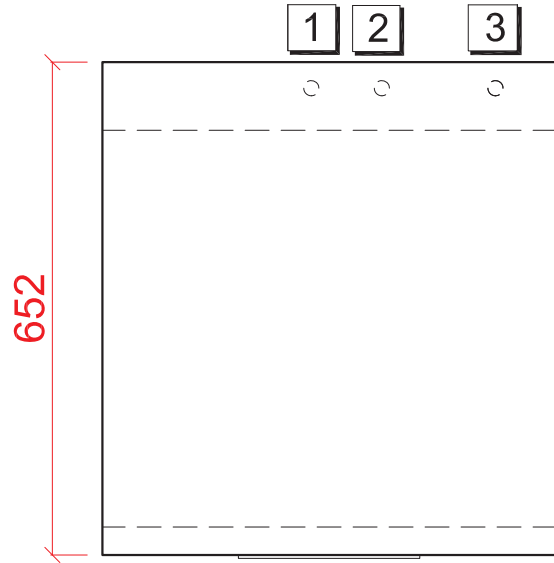

1 Water

2 Drain

3 Electric

22mm CONNECTION VIA 2 METRE FLEXIBLE HOSE, FEMALE TERMINATION.  
WATER SUPPLY 10°C TO 60°C (0° TO 3° CLARK MAX) @ 0.6 TO 6.0 BAR MAX. INITIAL TANK FILL 10.8 LITRES.  
**STANDARD RINSE - 45 CYCLES**  
RINSE WATER USAGE 2.0 LITRES PER CYCLE.  
MAX USAGE 90 LITRES PER HOUR.  
**VAPO RINSE - 21 CYCLES**  
RINSE WATER USAGE 1.0 LITRES PER CYCLE.  
MAX USAGE 21 LITRES PER HOUR.  
OUR MACHINES ARE SUPPLIED WITH CLASS 'AB' AIR GAP AS STANDARD.

DRAIN - 2 METRE FLEXIBLE HOSE TO A 40 mm TRAPPED STANDPIPE 800mm MAX A.F.F.L.  
FLOW RATE 30 LITRES PER MINUTE.

6.8kW 400/50/3 + N + E FUSED AT 3 x 16amps MACHINE SUPPLIED WITH 2.5 METRES OF CABLE (3 PHASE).  
**CONFIGURABLE TO:**  
4.7kW 230/50/1 FUSED AT 25 amps

Other Services

Notes

RINSE AGENT HOSE - 2.5 METRE FLEXIBLE.  
DETERGENT HOSE - 2.5 METRE FLEXIBLE.

APPROX WEIGHTS:  
EMPTY: 65kg's WITH WATER: 87kg's  
\* = + 40mm

PLOT SCALE: 1:10