

**HOOD TYPE DISHWASHERS
AUP SERIES**



HOBART UK,
SOUTHGATE WAY,
ORTON SOUTHGATE,
PETERBOROUGH.
PE2 6GN
0844 888 7777

www.hobartuk.com

Hood Type Dishwasher with Inbuilt Softener, Automatic Soil Removal and Drain Heat Recovery

AUPRSW-10B

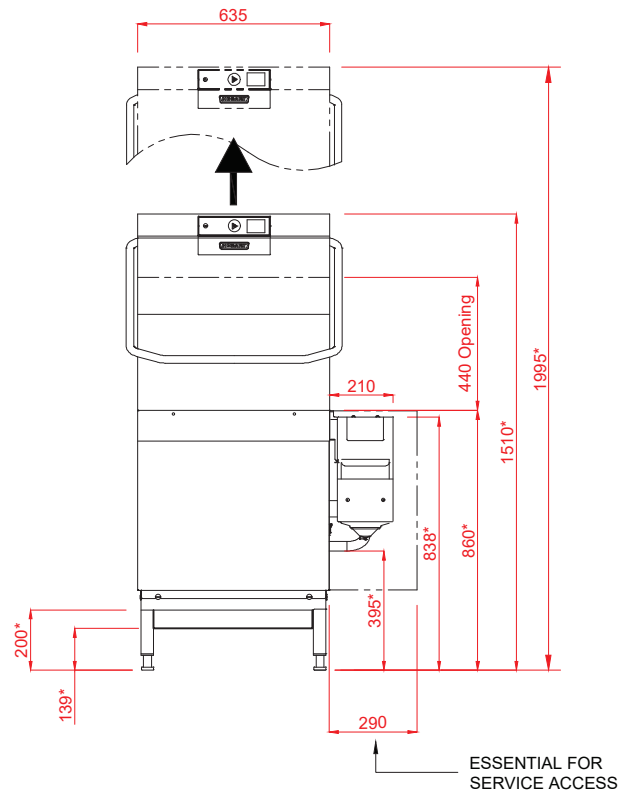
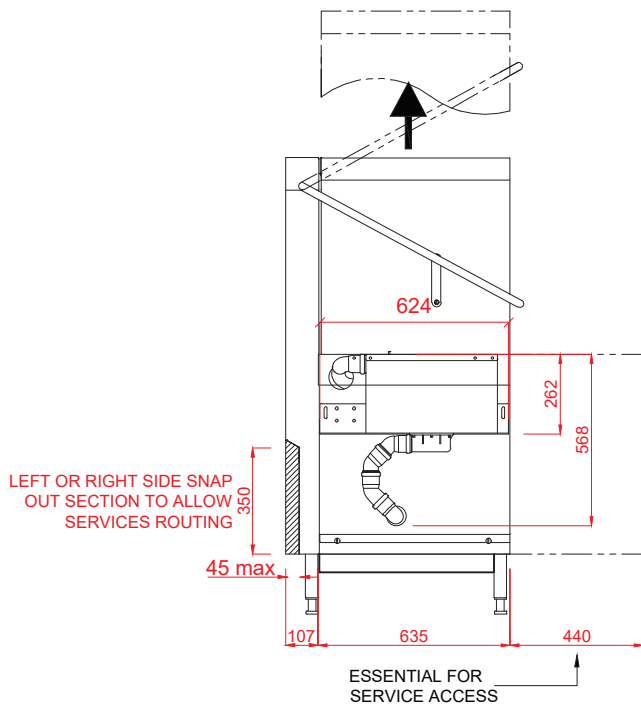
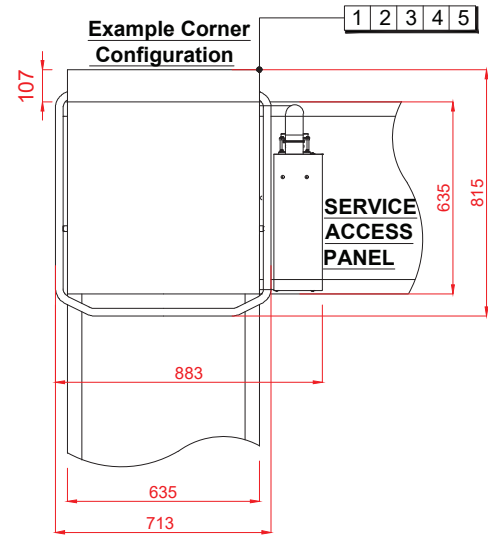

1 Water

22mm CONNECTION VIA 2 METRE FLEXIBLE HOSE, FEMALE TERMINATION.
COLD WATER SUPPLY **MAX 15°C @ 0.8 TO 10 BAR MAX.**
INITIAL TANK FILL 40 LITRES.

RINSE WATER USAGE (ECO) 1.4 LITRES PER CYCLE.
RINSE WATER USAGE 2.0 LITRES PER CYCLE. MAX USAGE 140 LITRES PER HOUR.
OUR MACHINES ARE SUPPLIED WITH CLASS 'AB' AIR GAP AS STANDARD.

2 Drain

DRAIN - 2 METRE FLEXIBLE HOSE TO A 40 mm TRAPPED STANDPIPE 500mm MAX A.F.F.L.

FLOW RATE 30 LITRES PER MINUTE.
DRAIN RATE TYPICALLY 3 MINUTES.

4 Other Services

RINSE AGENT HOSE - 2.5 METRE FLEXIBLE.
DETERGENT HOSE - 2.5 METRE FLEXIBLE.

3 Electric

17.5kW 400/50/3 + N + E
FUSED AT **35amps** / PHASE.
CONFIGURABLE TO:
11.3kW 400/50/3 + N + E
FUSED AT **25amps** / PHASE.
SUPPLIED WITH 2.5 METRES OF CABLE.

Notes

Approx Weights: EMPTY: 110kg WITH WATER: 130kg
Min distance to Wall to Inside of tabling boxed edge 154.5mm.
HEIGHTS MARKED * REPRESENT ±20mm.
AUTOMATIC SOIL REMOVAL UNIT CAN BE POSITIONED ON EITHER SIDE OF MACHINE.

PLOT SCALE: 1:25

RIGHT TO MAKE NECESSARY CHANGES IS RESERVED