

Undercounter Dishwasher with in-built Softener

F504SW-20B

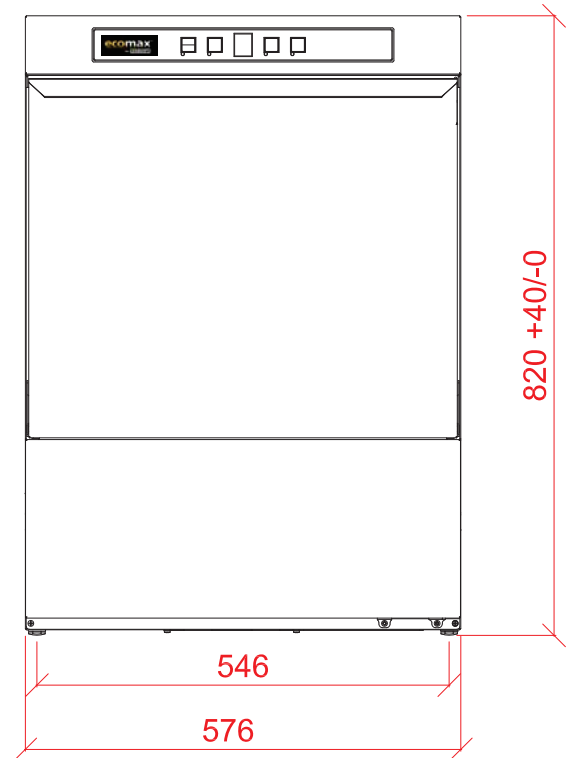
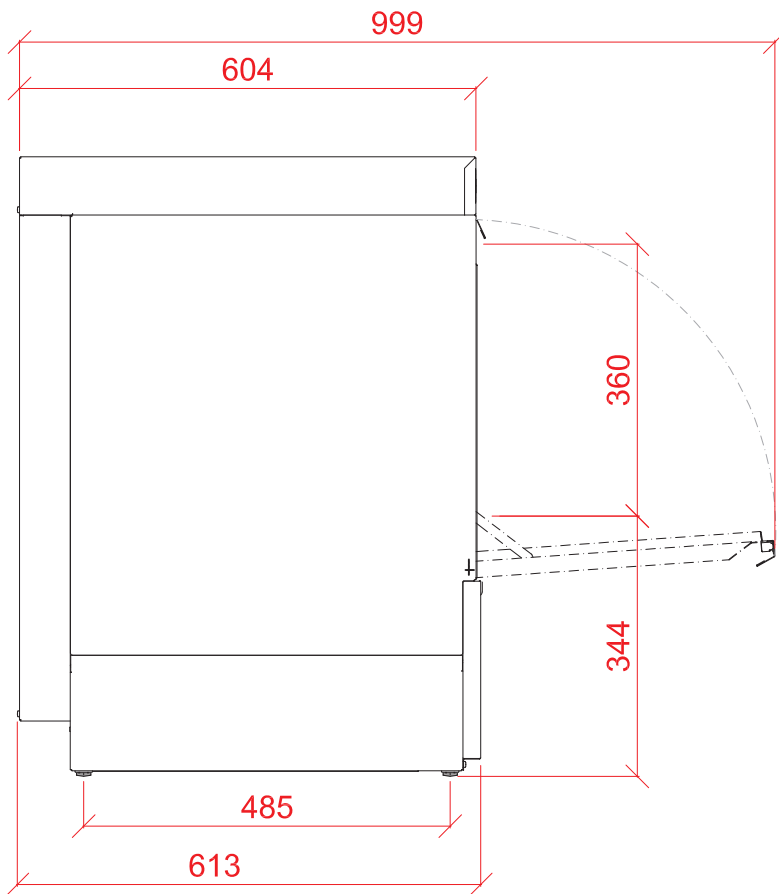
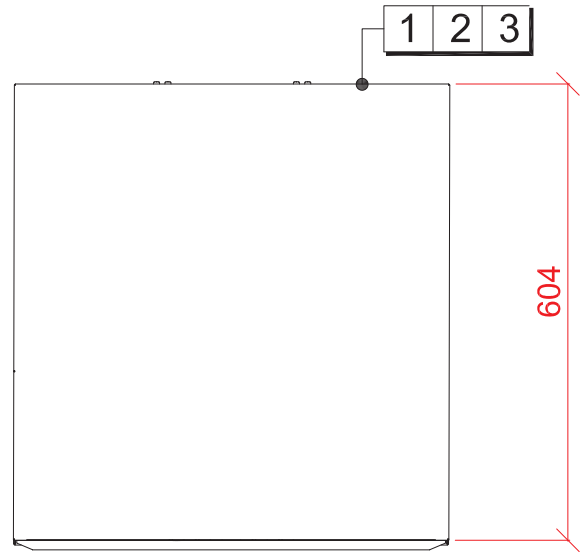

1 Water	2 Drain	3 Electric
22mm CONNECTION VIA 2 METRE FLEXIBLE HOSE, FEMALE TERMINATION. WATER SUPPLY 15°C TO 65°C @ 0.8 TO 6.0 BAR MAX. INITIAL TANK FILL 25 LITRES. RINSE WATER USAGE 2.3 LITRES PER CYCLE. MAX USAGE 138 LITRES PER HOUR. OUR MACHINES ARE SUPPLIED WITH CLASS 'AB' AIR GAP AS STANDARD.	DRAIN: 2.0 METRE FLEXIBLE HOSE TO A 40mm TRAPPED STANDPIPE 650mm MAX A.F.F.L. FLOW RATE 30 LITRES PER MINUTE.	4.1kW 230/50/1 FUSED AT: 1 x 25amps. CONFIGURABLE TO: 5.9kw 400/50/3 FUSED AT: 3 x 16amps 2.2kW 230/50/1 FUSED AT: 1 x 13 amps MACHINE SUPPLIED WITH 2.0 METRES OF CABLE
	Other Services	Notes
	RINSE AGENT HOSE - 2.5 METRE FLEXIBLE. DETERGENT HOSE - 2.5 METRE FLEXIBLE.	+40mm ADJUSTMENT FOR FEET NET WEIGHT 46kg.

PLOT SCALE: 1:10