

9. Pre-measured tie-up cords are supplied. Push the plain looped end through the hole in the lamm. Pull the other end through the first loop and tighten it on the lamm.

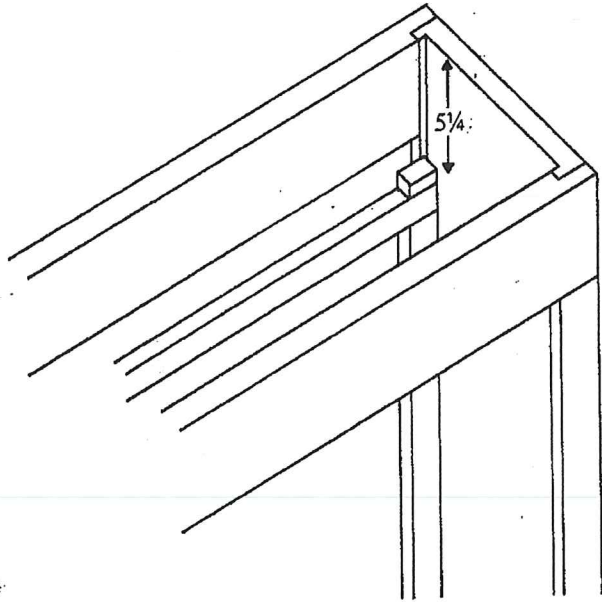

10. To attach the tie-up cords to the foot treadles, pull out the pin in the end of the treadle. Push the pin through the loops at the tied end of the tie-up cords and re-insert it into the end of the treadle.

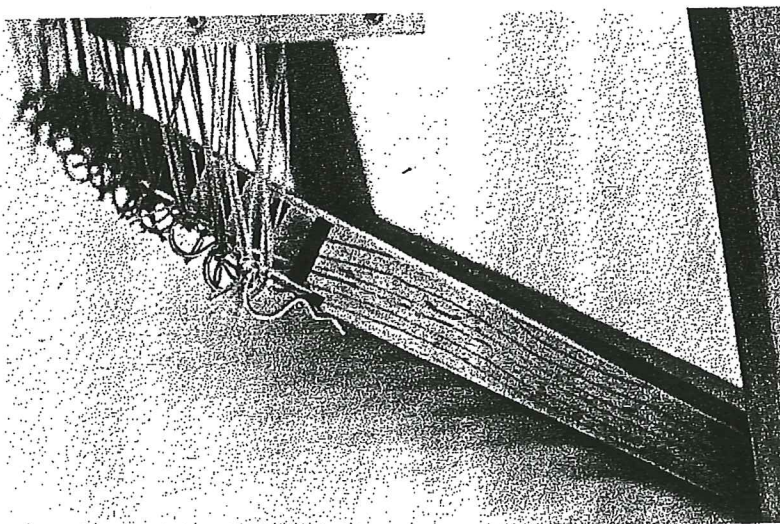

# SCHACHT SPINDLE COMPANY

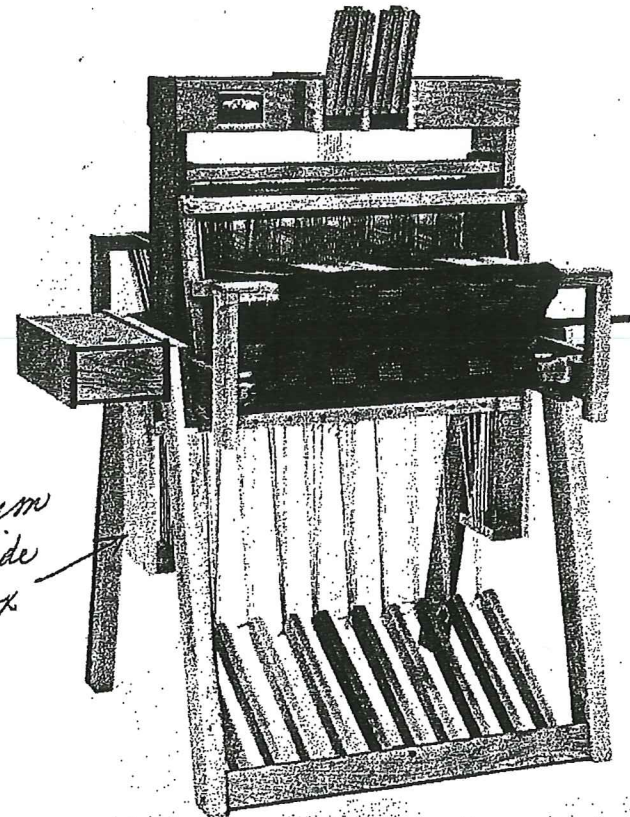

## FLOOR LOOM CONVERSION KIT

1708 WALNUT STREET BOULDER COLORADO 80302

## ASSEMBLY INSTRUCTIONS FOR THE FLOOR STAND

1. Lay the loom on one side and remove the two bolts which secure the castle. On the 8 harness loom remove the two rear bolts.
2. Fit one side of the floor stand over the side of the loom. (The leg with the holes in it faces the front of the loom.) Align the holes in the stand, loom side, and castle and insert the longer 1 3/4" bolts which came with the stand and tighten with the square nuts. (Keep the shorter bolts in case you want to use the table loom without the stand.)
3. Turn the loom over on the other side and attach the other floor stand legs.
4. Place the loom upright. Attach the shuttle box to the left side of the stand using the wing nuts and washers that are provided.
5. Attach the shelf to the right side of the stand with the 1" screws that are provided.

## ASSEMBLY INSTRUCTIONS FOR THE FLOOR LOOM CONVERSION KIT

1. Remove the strings from the levers and harnesses. (Place something under the harnesses so that they don't fall out.)
2. Remove the top rear castle cross piece by unscrewing the four screws that hold it on.
3. Remove the two 3/4" dowels and cross bars.
4. Attach the harness adapter. For looms produced before October 1976 you will need the harness adapter shown in photograph No. 1. For our more recent table looms only the pulleys and pulley bar is needed. These fit directly into two holes which have been drilled into the front and rear castle cross-pieces.

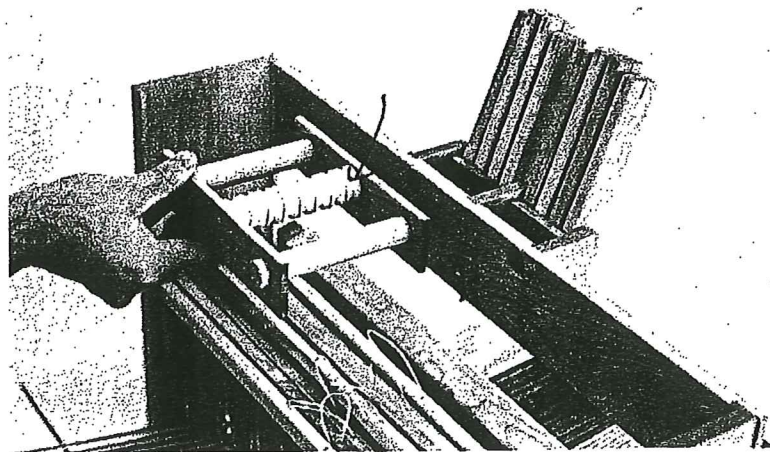
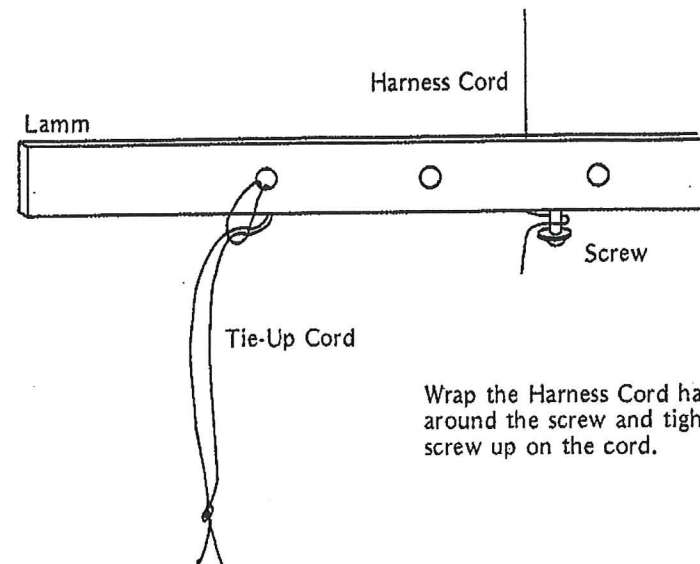

Photo 1

5. To attach the treadles, slightly spread the front legs of the floor stand and fit the treadle bar into the slots and holes in the front legs. Secure with the two 2" screws that are provided.
6. To attach the lamms first screw one of the lamm guide boxes onto one side of the floor stand using two of the 1" screws that are provided. Next slip one end of the lamms into the slots of the attached guide box. (Make sure that the small screws in the center of the lamms face down.) While supporting the lamms with one hand bring the other guide box up to the free end of the lamms and slip the lamms into the slots of the guide box. Finally raise the guide box up to the other side of the floor stand and attach it with the other two 1" screws.
7. Long harness cords with a knot in one end are supplied with the floor loom conversion kit. Slip the unknotted end of a harness cord up through the hole in the top of the first harness. Pull the cord all the way up and loop it down over the first pulley. Drop the harness cord down between the first and second harness. Do the same with each harness. The cord always drops between the harness to which it is attached and the next harness back.
8. Connect the harness cords to the lamms. (see drawing A.) Starting with the eighth lamm, push the harness cord down through the hole in the center of the lamm. Push the lamm up to the top of the guide boxes and hold it there. Now pull the harness cord down until the top of the harness is 5/4" below the top of the castle. Wrap the cord halfway around the screw that is on the bottom of the lamm and tighten the screw. Working your way toward the front of the loom, do the same for each harness and lamm. All harnesses should hang at the same height.



Wrap the Harness Cord halfway around the screw and tighten the screw up on the cord.

Drawing A