

SL2228

ARRAS TRAP™

ASSEMBLY

PARTS

- 2X trap sides
- 2X dowels
- 1X trap cloth
- 2X 3/4" nylon spacers
- 2X #8 x 1-1/4" Phillips truss head sheet metal screws
- 4X #6 x 3/4" Phillips pan head sheet metal screws
- 2X knobs with 1-1/4" shafts
- 2X T-nut slides

TOOLS REQUIRED

#2 Phillips screwdriver

ARRAS TRAP™

ASSEMBLY

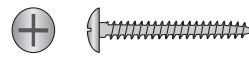

Phillips truss head sheet metal screw

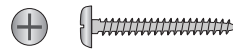

Phillips pan head sheet metal screw



T-nut slide



nylon spacer

trap side, inner face



black nut for knob

holes for dowels

trap side, outer face



hole for support

ASSEMBLE THE TRAP

1. Orient the trap sides as shown in Figure 1: the inner face of each trap side has two large holes at the front for the dowels and a black nut at the back for the knob. In the remaining hole, you will attach a nylon spacer as trap support on the outer face of the side. Insert a #8 x 1-1/4" Phillips truss head sheet metal screw through a 3/4" nylon spacer, then attach to a trap side. Repeat with the remaining trap side.

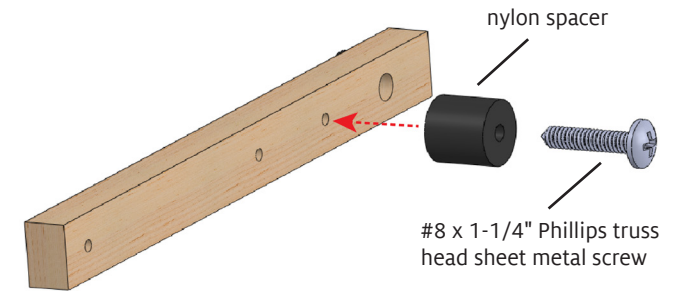

FIGURE 1: ATTACH TRAP SUPPORTS



Find out more at schachtspindle.com
 Schacht Spindle Company
 6101 Ben Place Boulder, CO 80301
 p. 303.442.3212

2. Insert dowels through the sleeves of the trap cloth (Figure 2).
3. Lay out the parts on a work surface as shown in Figure 3: dowels and trap cloth in the middle, trap sides with supports facing outward on either side. Using #6 x 3/4" Phillips pan head sheet metal screws, attach the trap sides to the dowels.

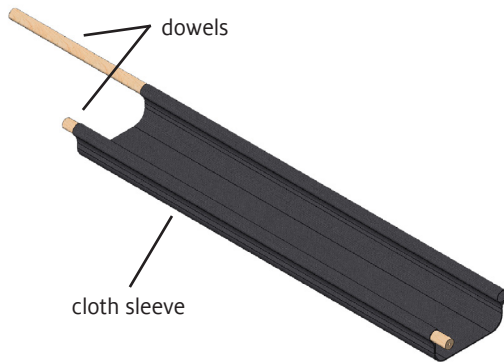

FIGURE 2: INSERT DOWELS IN CLOTH SLEEVE

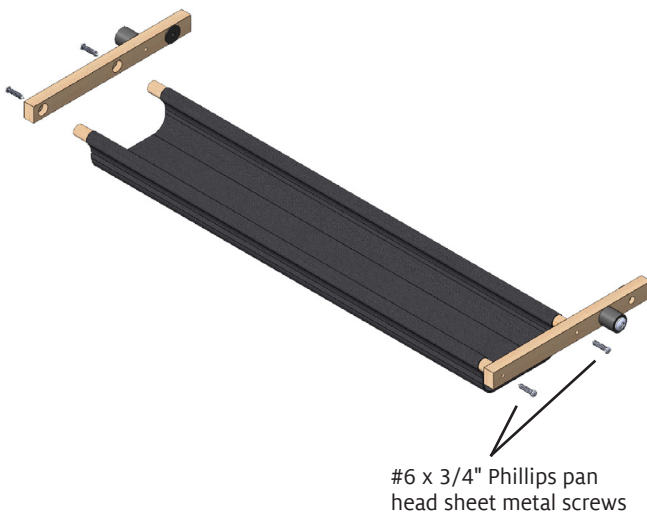

FIGURE 3: ATTACH DOWELS

INSTALL THE TRAP

4. Insert a knob with a 1-1/4" shaft through a T-nut slide as shown in Figure 4. Repeat with the other knob and T-nut slide.
5. Place the trap in your desired location: it can attach to the Arras Loom through the slots in the loom uprights above the shedding device (Figure 5A), or to the Arras Stand through the slots in the front legs (Figure 5B). Insert the knobs through the slots and into black nuts in the trap sides; tighten the knobs.

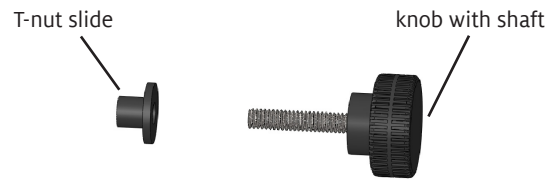

FIGURE 4: INSERT KNOB INTO T-NUT

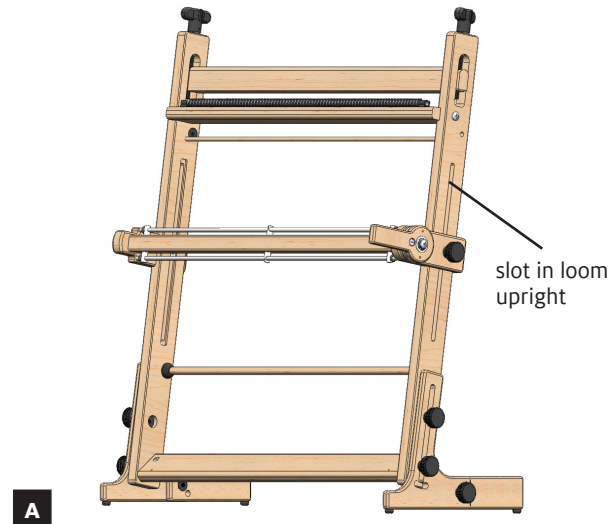
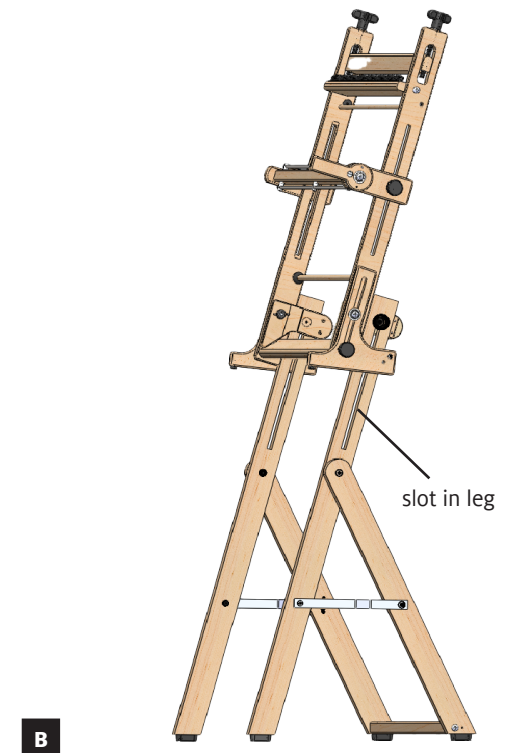

FIGURE 5: INSTALL ON ARRAS LOOM OR STAND



Find more products on our website!

