

mini Loom

all you need to do is weave



*Includes loom,
two shuttles,
weaving needle,
beater, yarn*



*step-by-step
instructions*

Glossary of Weaving Terms

Pick: one weft pass.

Plain weave: the most basic weave, over, under, over, under.

Selvedge: the edge threads on a piece of weaving.

Shuttle: tool that holds the weft for weaving.

Warp: the threads stretched taut on the loom.

Weft: the threads that weave across the warp.

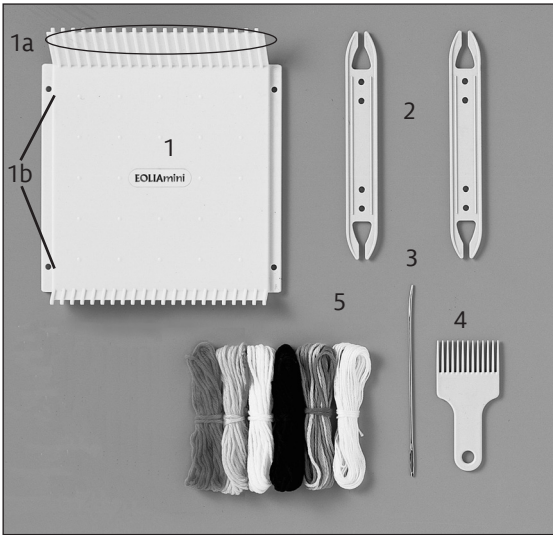

1—Mini Loom, 1a—warping teeth, 1b—tie-on holes, 2—2 shuttles, 3—1 weaving needle, 4—1 beater, 5—5 colors of yarn, plus warp yarn (not shown)

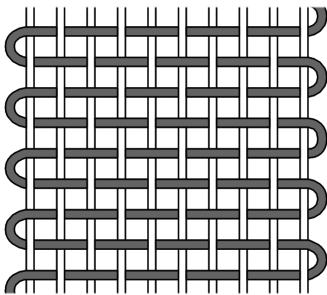

Balanced plain weave:

Equal number of warps and wefts.

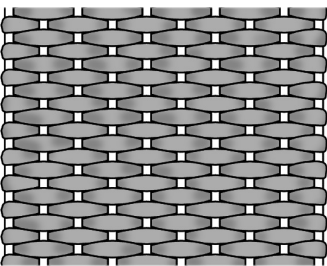

Weft-faced plain weave:

The weft covers or partially covers the warp.

Winding the Shuttle

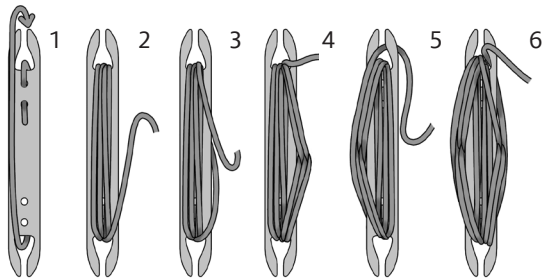

Secure the yarn in the center holes as shown in 1.

Wrap around the length of the shuttle as shown in 2 and 3.

To wrap more yarn on the shuttle, wrap in a figure—8 fashion on one or both sides of the shuttle, as shown in 4-6.

Warping the Mini Loom

- Securely tie the warp yarn to a tie-on hole.
- Begin warping at the desired width of your project.
- Wind back and forth, going around the warping teeth directly opposite each other.
- Finish by securely tying the end in a tie-on hole.

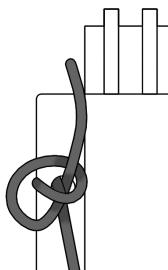

Begin by tying the end through a tie-on hole.

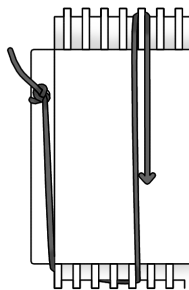

Hint:
Make sure to choose warping teeth directly opposite each other.

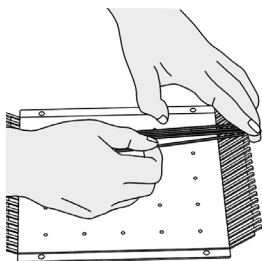

Hint:
When warping, it is helpful to hold the yarns down as you go around the warping teeth.

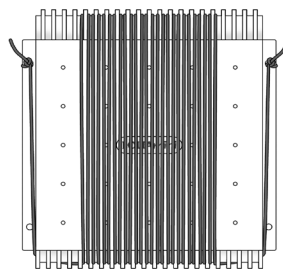

The loom is warped and ready for weaving.

Weaving

Weaving is the process of interlacing two sets of yarns: the warp that is stretched taut on the loom and the weft that crosses it.

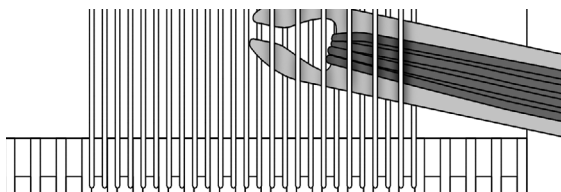

Using the shuttle, weave over, under, over, under all the way across the warp.

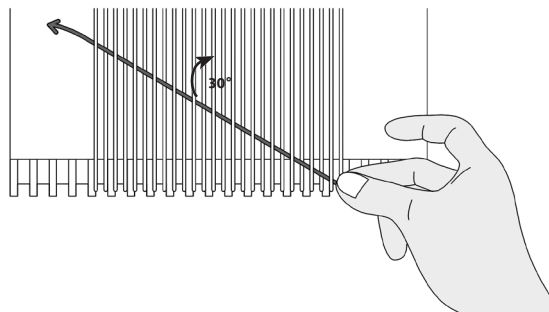

Hold the yarn at the edge, or selvedge, and place the yarn at a 30 degree angle. Press the yarn into place with the beater.

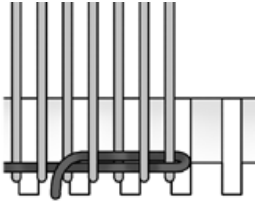

Secure the weft tail by going around the selvage thread and inserting it under a few warps.

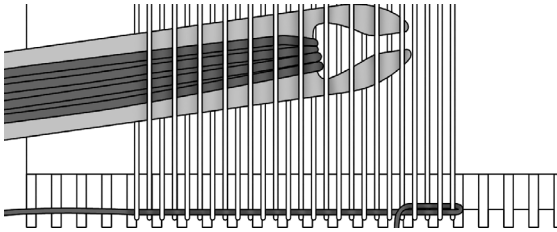

Weave the second weft, or pick, by weaving back, going over the opposite threads. (If you went over a thread, you'll go under it on this pass.) This over, under, over, under interlacement is the most basic of weaves. It is called plain weave.

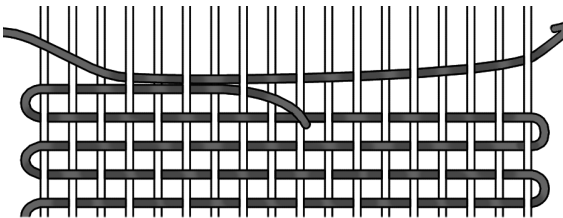

To make a join, overlap the two yarns.

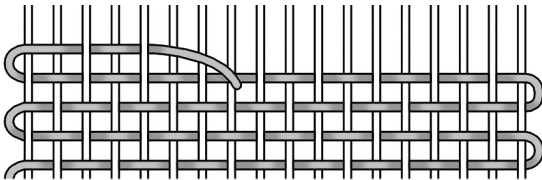

To end your weaving, weave the weft tail back under a few warp threads.

Finishing

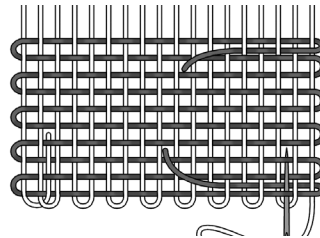
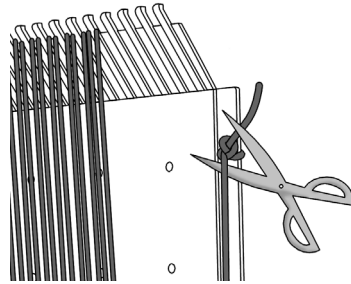

To remove the weaving from the loom, cut off the tie-on warp end and weave it back into the weaving using the weaving needle. Fix any weaving errors (see below), and then wash your fabric, clipping off all tails.

Fixing Errors

If you notice a weaving error, you can fix it. Where the error occurs, weave a short piece of yarn in the correct path, overlapping on either side of the error. Clip out the errant thread as shown.

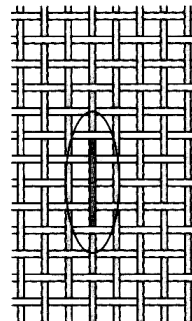

Notice one end floats over three threads.

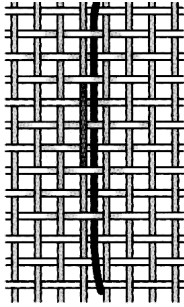

Weave a repair thread in the correct path.

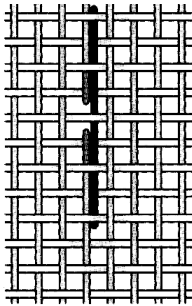

Clip out errant thread.

Securing the Weft

To prevent the weft from raveling, you'll need to finish the edge to keep the weft from coming out. Below are a few ways to finish your edges.

Overhand knots

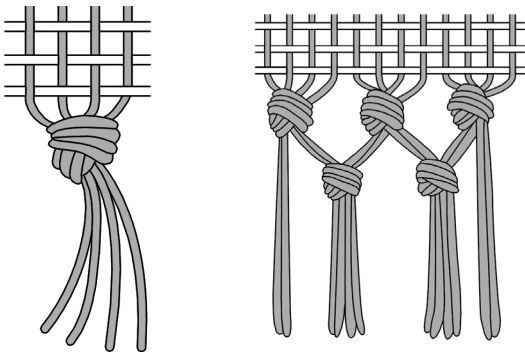

- The simplest finish is to tie groups of warps together to make a fringe. A more elaborate finish can be made by dividing groups in half and tying a warp group in between.

Twisted fringe

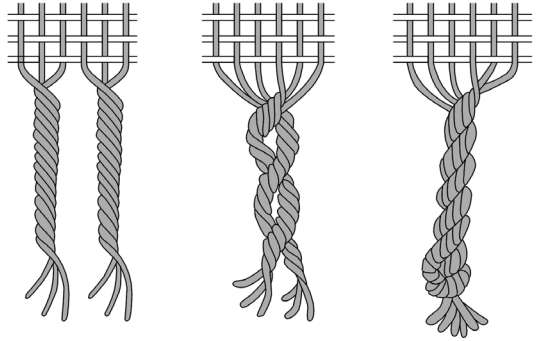

- A twisted fringe is a good finish for longer fringes. Step one: twist two groups to the right; step two: place the two groups together and twist to the left; step three: tie an overhand knot in the end to secure.

Philippine Edge

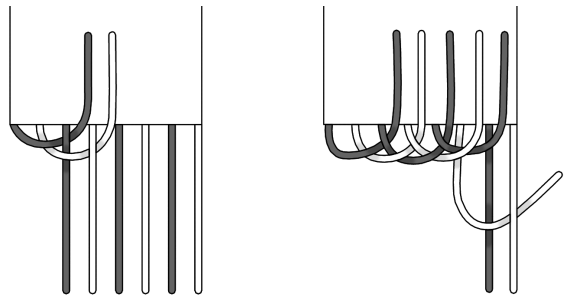

- A Philippine edge makes a fringe that lies flat. This is an excellent finish to choose for a short fringe. One row is enough to secure the weft. If you do two or more rows, you'll make a decorative finish. Work in this way: Place the 1st thread over the 2nd thread and under the 3rd. Next, place the 2nd thread over the 3rd and under the 4th. Repeat in a like manner across the entire warp.

Cell Phone Case



Overview

Weave 2 rectangles, stitch them together, tie a fringe, and then crochet a trim and handle.

Warping

Using the white warp yarn, tie on as shown, and then wind 16 threads (8 rounds) onto your Mini Loom.

Weaving

Use colored yarn and weave four 1 1/4" stripes, each a different color. After you've woven a few rows, push the weft up against the warping teeth so that when you remove the weaving, you'll have a finished edge. Unwoven warp will be left at the other end and will form the tied fringe. Weave a second piece identical to the first.

Assembly

Place the two pieces together and join using the lacing stitch. At the bottom of the case, join the two pieces together by tying a fringe.

Finishing the top and making the handle

Use a crochet hook to finish the top of the case and to make the handle. Crochet across the top edge on one side. Without breaking the yarn, single crochet the handle for 30". Then join the handle to the bag at the other edge and then finish by crocheting across the other top edge.

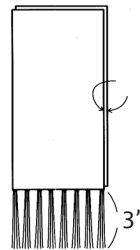
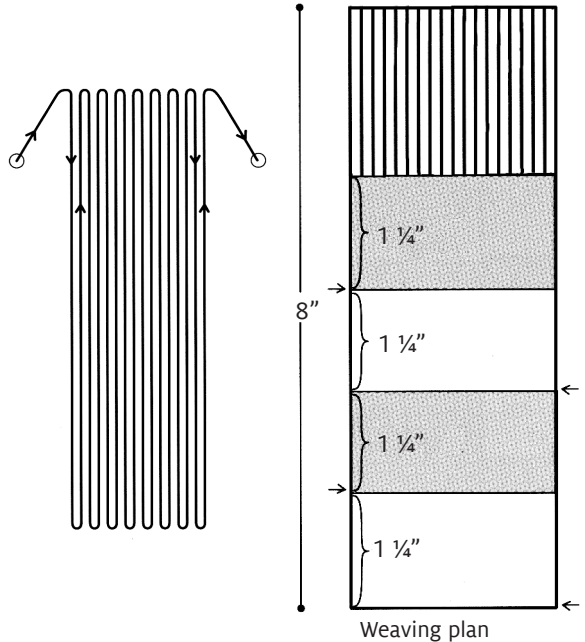

Sew the two sides together

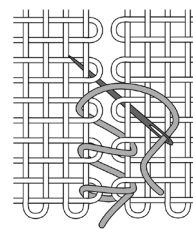

Lacing stitch

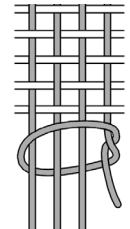

Tie fringe to join the bottom

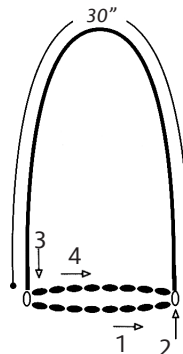

Crocheting the handle and finishing the top edge

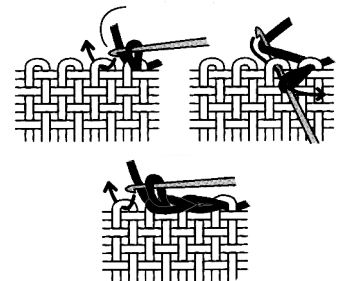

Crochet trim for the top of the bag

Mug Rug



Overview

A striped warp is crossed with a striped weft to form a plaid. Fringe is woven on all four sides, and secured with overhand knots.

Warping

Begin and end the warp in the tie-on holes. Measure 6 threads of color A, 6 threads of color B, and 12 threads of color C, following the path shown.

Warping Two Colors

Tie on the second color in the second tie-on hole. Carry the yarn behind the teeth and place it in the desired warping tooth. Change to the first color in the same manner. When finished warping, tie off the ends as shown.

Weaving

Insert a 2" spacer to hold the space for the tied fringe. To weave the side fringe, weave all the way over to the tie-on warps, and turn around on these threads (see illustration). Using two different colors, weave 6 picks of color D, 6 picks of color E, and 12 picks of color D. Adjust the weft yarns so that your mug rug is square.

Finishing

Cut from the loom, secure all tails, and then tie overhand knots.

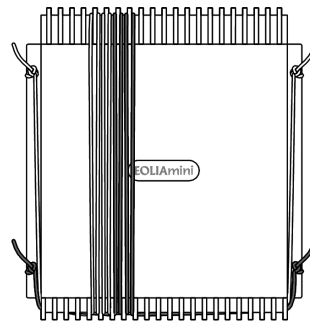

Warping Two Colors

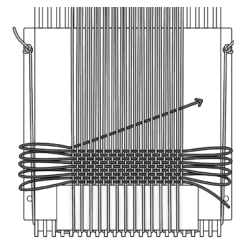

To weave weft fringe, turn around on the tied on end. Angle the weft to prevent it from drawing in.

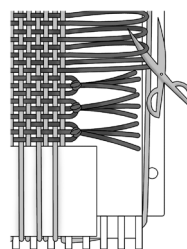
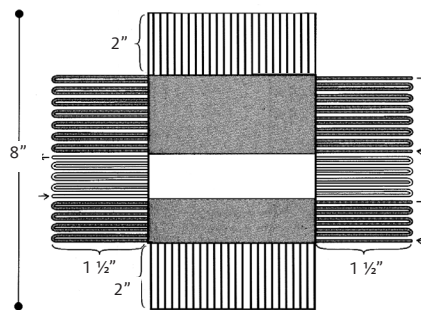

Cut side weft loops

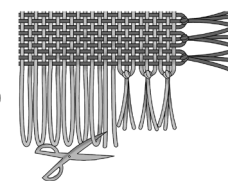

Cut warp loops

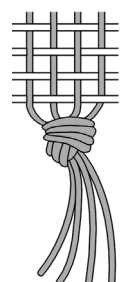

Tie overhand knots to secure

Little Knotted Bag

(Note: Yarns for this project are not included in the Mini Loom Kit.)

Warp and Weft Yarns

Warp

Use cotton carpet warp or strong string and warp the full width of the loom.

Weft

This project uses a tweed worsted weight wool yarn in blue, 8 colors of sport weight wool yarn, and a small amount of worsted weight wool yarn in white and rust.

Weaving

Front: Weave 6 rows of plain weave, beating to cover the warp. Work rya knots using four strands of sport weight yarn. Work the pattern as follows, skipping the selvedge threads on each row: Make the knots over two warps skipping a pair of warps between each knot. Weave 6 rows of plain weave. Work another row of rya as before, but offset the knots, tying them around the two warps skipped in the first row of knots. Weave another 6 rows of plain weave and repeat alternating sections of rya knots and plain weave until 13 rows of knots have been made, about 5". The knot color sequence is: blue, pink, orange, yellow, white, green, purple, rust.

Border: Using worsted weight yarn doubled, make a row of soumak. With rust worsted weight yarn, weave $\frac{3}{4}$ " of plain weave, beating firmly. To remove from the loom, lift the warp ends off the hooks, cut the loops one at a time and sew the ends back into the weaving.

- *Back:* Weave plain weave with solid tweed worsted weight wool yarn and make the top border to match the front.
- Remove from the loom and secure the warp ends as you did for the front. Trim the knots to about $\frac{3}{8}$ ".

Assembly

- Secure all of the ends and steam press on the wrong side.
- Sew the front and back together using a lacing stitch and tweed yarn. For the top edge, cut twenty-one 4" lengths of doubled rust worsted weight wool yarn. From the front side of the bag, insert a crochet hook two rows from the top, and pull the doubled yarn through to the front, creating a loop. Insert the ends through the loop and draw tight.
- Repeat across the top of the bag spacing the knots evenly.
- Trim to about $\frac{3}{8}$ ". For the handle, make a twisted cord using the Incredible Rope Machine. Tie an overhand knot in each end and hand stitch the twisted cord to the sides.

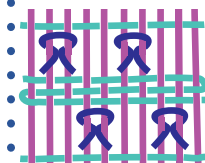

Rya Knots

Work on a closed shed, using small lengths of yarn that are knotted onto the warp as illustrated.

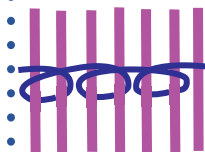

Soumak

Work soumak on a closed shed. Start at one edge, encircle one or more warp threads and then go on to the next group as illustrated.

mini Loom



Find out more at schachtspindle.com
Schacht Spindle Company 6101 Ben Place Boulder, CO 80301
p. 303.442.3212 f. 303.447.9273