

FL3801

FL3803

LOOM BENCH & BENCH BAG

ASSEMBLY



SHOWN IN MAPLE AND CHERRY WITH OPTIONAL BENCH BAGS



Find out more at [schachtspindle.com](https://www.schachtspindle.com)
Schacht Spindle Company 6101 Ben Place Boulder, CO 80301
303.442.3212

© 2022 Schacht Spindle Company, Inc.

11.22

LOOM BENCH

ASSEMBLY

PARTS

- 2X seat supports
- 2X height adjusters
- 2X left uprights
- 2X right uprights
- 2X bases
- 2X middle supports
- 2X bench seats
- 4X 1/4-20 x 3-1/4" carriage bolts
- 8X 1/4" USS flat washers
- 4X 1/4" lock washers
- 4X 1/4-20 hex nuts
- 8X 1/4-20 barrel nuts
- 4X 1/4-20 x 3-1/2" Phillips truss head machine screws

- 4X 1/4-20 x 2" Phillips truss head machine screws
- 2X 5/16-18 x 6-1/2" hex bolts
- 2X 5/16 hex nuts
- 10X #10 x 1-3/4" Phillips flat head sheet metal screws (extras included)

TOOLS REQUIRED

- #2 Phillips screwdriver
- slotted (flat) screwdriver
- 1/2" and 7/16" wrenches (or adjustable)
- hammer or mallet

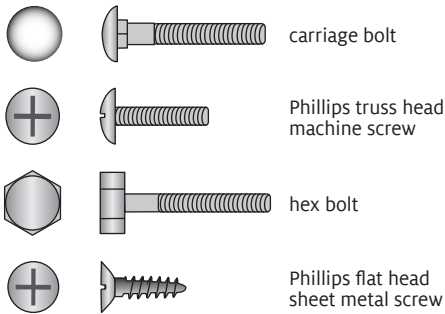

Hardware is not drawn to scale. Measure the shafts of bolts and screws to determine length.

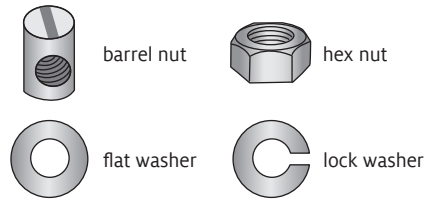

1. Decide on a flat or slanted bench seat. For a flat seat, orient the seat supports with their flat edges on top and the grooved inner sides facing each other (Figure 1A). For a slanted seat, orient the seat supports with the slanted edges on top and the grooved sides facing each other; install the shorter edges at the front of the loom bench (Figure 1B).

2. Place a height adjuster in the grooved inner side of a seat support, aligning holes as shown in Figure 1C. From the outer side of the seat support, insert a 1/4-20 x 3-1/4" carriage bolt into each hole. Using a hammer, tap the heads of

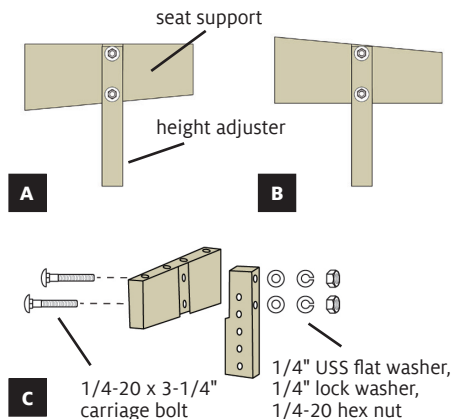

FIGURE 1: ASSEMBLE SEAT SUPPORTS

the carriage bolts into the wood. Repeat for the remaining height adjuster and seat support.

3. From the inner side of the seat support, place a 1/4" USS flat washer, a 1/4" lock washer, and a 1/4-20 hex nut on each carriage bolt shaft. Tighten the hex nuts securely. Repeat for the remaining height adjuster and seat support.

4. Lay a left upright and a right upright flat on a work surface, orienting them so their grooved inner sides form a V, as shown in Figure 2A. Insert a 1/4-20 barrel nut in the holes at their lower ends.

5. Place a base at the lower ends of the uprights, as shown in Figure 2B. From the underside of the base, insert a 1/4-20 x 3-1/2" Phillips truss head machine screw into each hole and tighten into the barrel nuts in the uprights. Repeat for the remaining uprights and base.

6. Fit the middle supports into the grooved inner sides of a left upright and a right upright (Figure 2B). Attach them with 1/4-20 x 2" Phillips truss head machine screws and 1/4-20 barrel nuts. Repeat at the other end of the middle supports. The loom bench can now stand up.

7. Fit the height adjusters between the top ends of a left and right upright, with the seat supports facing outward, as shown in Figure 3. Align the topmost hole in the height adjuster with the holes at the top of the uprights. (You can adjust the height after you finish assembly.) From the front of the bench, insert a 5/16-18 x 6-1/2" hex bolt through a 1/4" USS flat washer, then through all these holes. Secure the hex bolt with a 5/16 hex nut. Attach the remaining height adjuster and seat support at the other side of the loom.

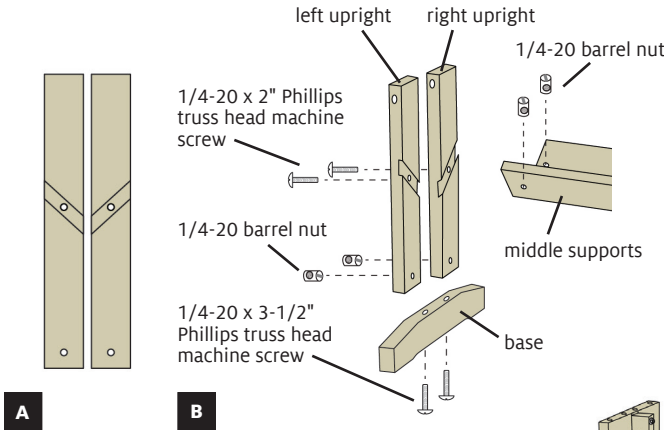

FIGURE 2: ASSEMBLE BENCH SIDES

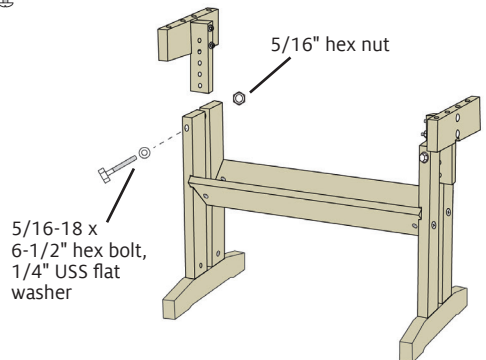

FIGURE 3: INSTALL HEIGHT ADJUSTERS

8. Orient the bench seats with the countersunk holes up and the squared edges next to each other, so the rounded edges run along the front and back of the bench. Place the bench seats on top of the seat supports, aligning the holes as shown in Figure 4. Attach the bench seats with eight #10 x 1-3/4" Phillips flat head sheet metal screws.

Your bench is now fully assembled at a height of 20". To adjust the height, remove the hex bolts attaching the height adjusters to the uprights (shown in Figure 3)—the bench seats, seat supports, and height adjusters remain attached to each other.

Raise or lower the height adjusters to your preferred height and reattach the hex bolts as you did in Step 6. The height adjusters have holes at 1" increments, for a minimum height of 20" and a maximum height of 24".

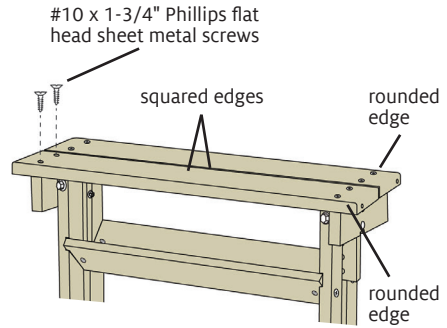

FIGURE 4: ATTACH BENCH SEATS

BENCH BAG ASSEMBLY

PARTS

- 2X steel rods
- 1X cloth bag
- 1X wood bag end

1. Rub the bar soap on each end of the steel rods.
2. Using a hammer or mallet, gently tap the steel rods into the holes of the bench seats. Place a scrap of wood between the hammer and rods to protect the rods.

TOOLS REQUIRED

- hammer or mallet
 - scrap wood
 - bar soap
3. Slip the sleeves of the cloth bag over the steel rods.
 4. Place the wood bag end on the steel rods, aligning its holes to fit over the rods. Using a hammer or mallet, and scrap wood to protect the wood, gently tap the bag end into place. ■

