

# GOKO METAL SWIFT

## ASSEMBLY INSTRUCTIONS



Find out more at [schachtspindle.com](http://schachtspindle.com)

Schacht Spindle Company 6101 Ben Place Boulder, CO 80301

p. 303.442.3212 800.228.2553 f. 303.447.9273

© 2014 Schacht Spindle Company, Inc.

08.14

# GOKO STAND

## ASSEMBLY INSTRUCTIONS

### HARDWARE

- 2 – 3½" truss head machine screws
- 4 – 2" Truss Head Machine Screws
- 6 – barrel nuts

### TOOLS

- Phillips Screwdriver
- Flat Head Screwdriver

### PARTS

- 2 – Goko bases
- 2 – Goko cross braces
- 2 – Goko uprights

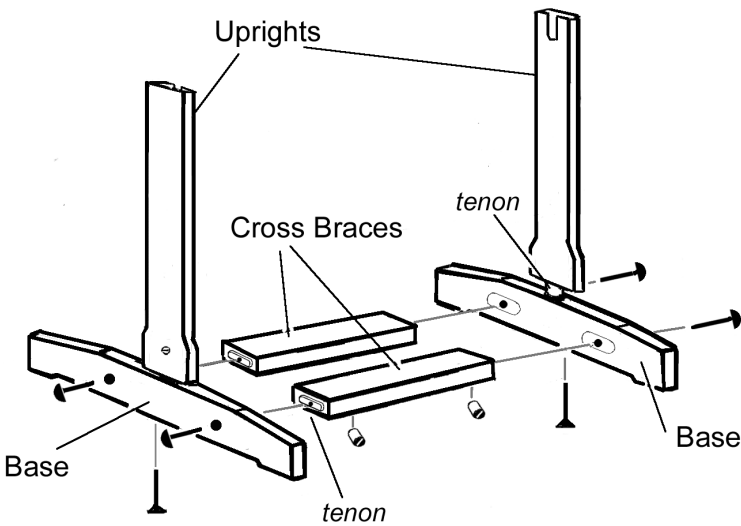

### ASSEMBLY

**1.** Insert the tenoned end of a Goko cross brace into one of the slots in the Goko Base. Place a barrel nut into the hole in the flat surface of the cross brace and screw in the 2" truss head machine screw through the outside of the base and into the cross brace and the barrel nut. Repeat these steps to attach the other base to the cross braces.

**2.** Insert the tenoned end of one of the Goko uprights into the slot in the top of one of the Goko bases. Orient the uprights with the vertical slot facing in. Place a barrel nut into the hole in the upright and screw in the 3" flat head machine screw through the bottom of the base into the upright and the barrel nut. Repeat this step for the other upright.

# GOKO METAL SWIFT

## ASSEMBLY INSTRUCTIONS

### PARTS

- 1 – flanged core
- 2 – flange covers
- 1 – Goko axle
- 1 – notched axle nut
- 1 – threaded axle nut
- 8 – Goko arms

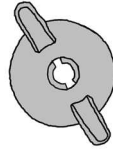

NOTCHED AXLE NUT

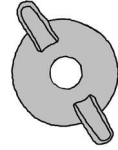

THREADED AXLE NUT

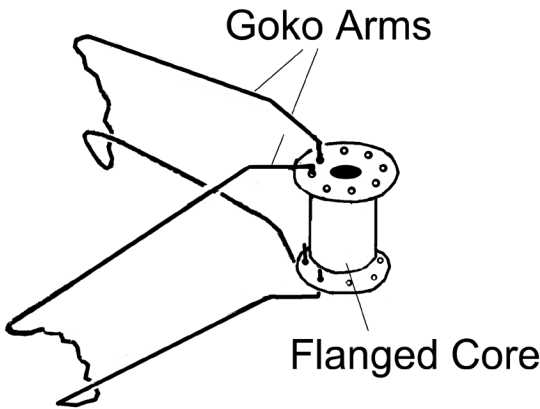

### ASSEMBLY

1. Position the Notched Axle nut on the Goko Axle by pushing the nut domed side first, over the threaded end of the axle across to the opposite side. Press the notches of the nut firmly onto the tabs on the axle. Set aside.
2. Place the flanged core on a table so that the holes are vertical. Attach the first Goko arm by sliding one of the bent tips of the arm into one of the eight holes around the perimeter of the top flange. Place the other bent tip of the arm into the corresponding hole in the bottom flange. Repeat these steps until all arms are attached and pointing in the same direction. It's helpful to keep the flanged core on the table while attaching the arms. This helps to keep the arms in position.
3. Space the Goko arms evenly around the flange and place one of the flange covers over the top flange with one arm in each slot of the flange cover.
4. Hold the flange cover firmly in place with one hand and turn the entire assembly over so that the flange cover is on the bottom. Pick up the Goko axle and push the long end of the axle up from the bottom through the hole in the flange cover and hold it there with your hand. Place the second flange cover over the axle and then align the cover's slots with the arms. Put the threaded axle nut onto the top of the axle and tighten it.
5. Remove rubber bands from Goko arms.

## ADJUSTING THE GOKO TO DIFFERENT SKEIN SIZES

Hold the center of the flanged core in your left hand. Loosen the nut about one full turn, or until you can easily move the core by holding the flange cover in place with your right hand and twisting the core with your left hand. Experiment twisting both directions. You will see the arms expand and contract. When the arms are contracted, place your skein over the arms and then expand the arms to fit your skein. Tighten the nut to lock the arms.

Place the assembled Goko swift in the wooden stand with ends of the axle in the slots of the uprights.

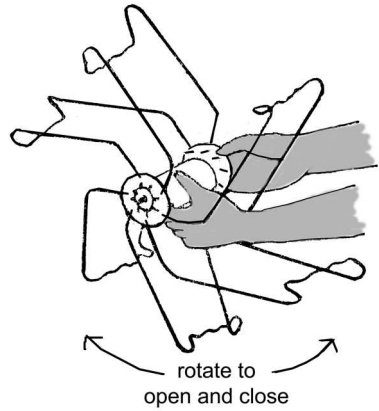

## HELPFUL HINTS

During assembly leave the rubber bands on the flat outer end of the arm to help keep the tips spread apart.

When unwinding yarn from your Goko be sure to have the yarn pulling from the bottom of the swift to prevent tipping. ❑